

THIS DRAWING IS UNPUBLISHED. RELEASED FOR PUBLICATION  
 © COPYRIGHT - By - ALL RIGHTS RESERVED.

REVISIONS				
P	LTR	DESCRIPTION	DATE	APVD
U		REV PER ECO-16-015655	23MAY16	CT RL

1. WIRE BARREL WILL ACCEPT #22-28 AWG WIRE.
2. HAND CRIMPING TOOL MIL PART NUMBER M22520/2-01 (TE 601966-1) WITH APPLICABLE POSITIONER
3. ---
4. NET WEIGHT- .072 GRAMS.
5. INSERTION, EXTRACTION TOOL- AMP P/N 91067-1.
6. ---

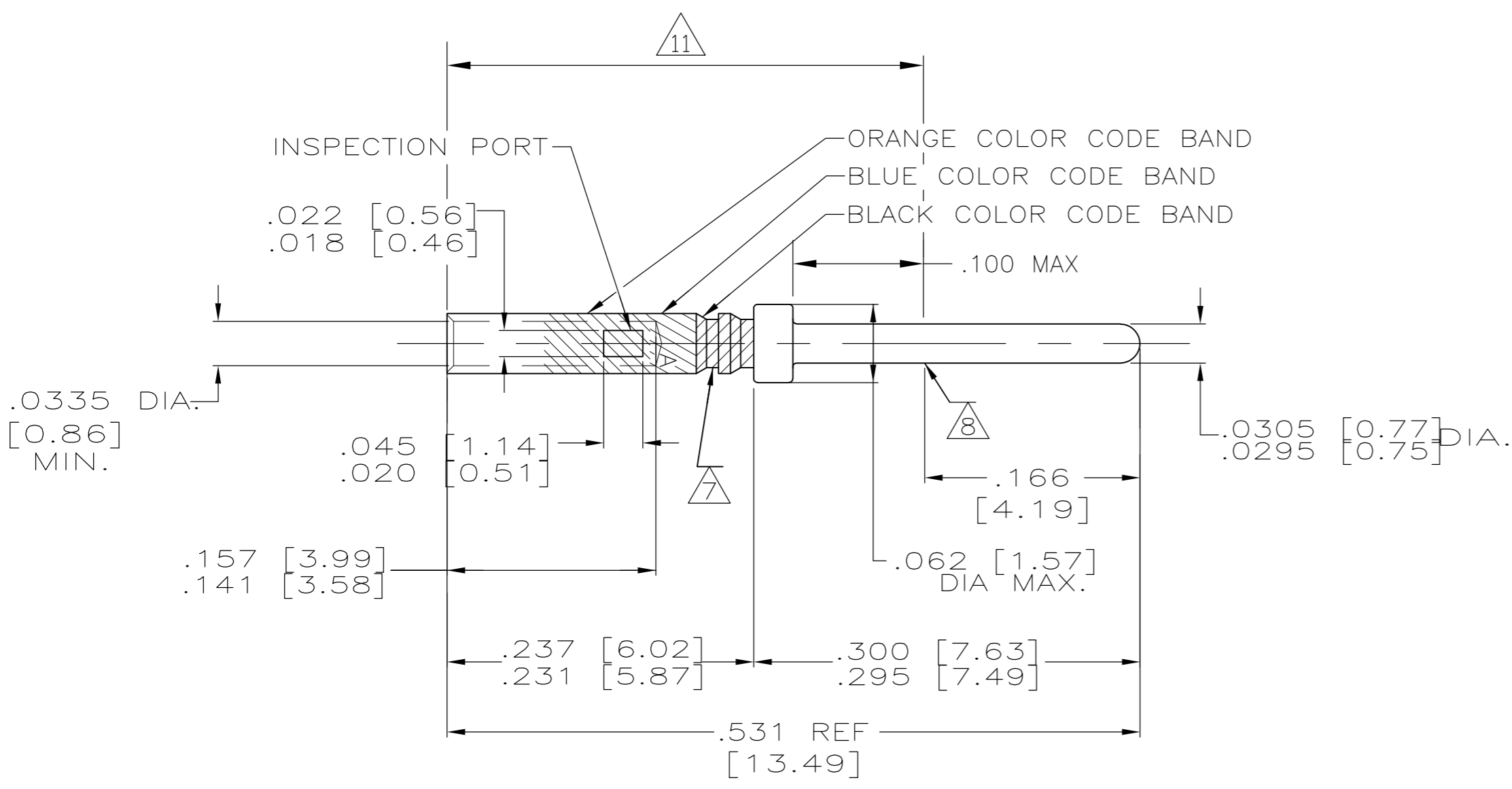

7. IDENTIFICATION GROOVE IS OPTIONAL.
8. POINT OF PLATING THICKNESS MEASUREMENT.
9. PLATING: GOLD PER ASTM-B-488 OVER NICKEL PER QQ-N-290.
10. PLATING: GOLD PER ASTM-B-488 OVER COPPER PER AMS 2418
11. MANUFACTURER'S LOGO ("A" OR "- . .") MARKED IN THIS AREA.
12. CONTACTS QUALIFIED TO AS39029/58-360
13. CONTACTS QUALIFIED TO GSFC-S-311-P-4/08, NASA P/N G-08-P1
14. CONTACTS MUST MEET DIMENSIONAL & PERFORMANCE REQUIREMENTS OF GSFC-S-311-P-4/08, NASA P/N G-08-P1 & 100% RESIDUAL MAGNETISM.

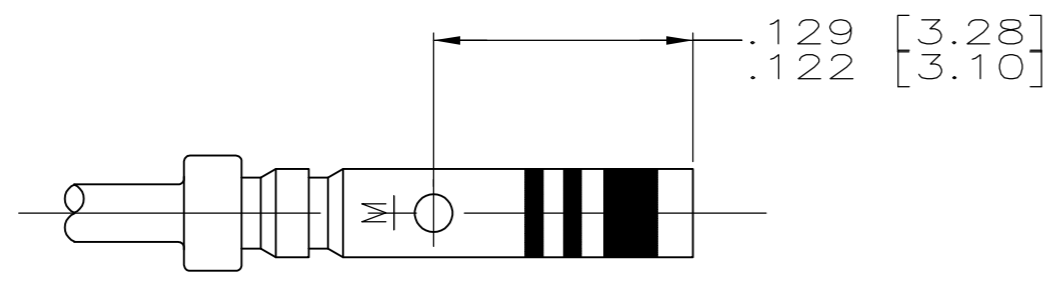
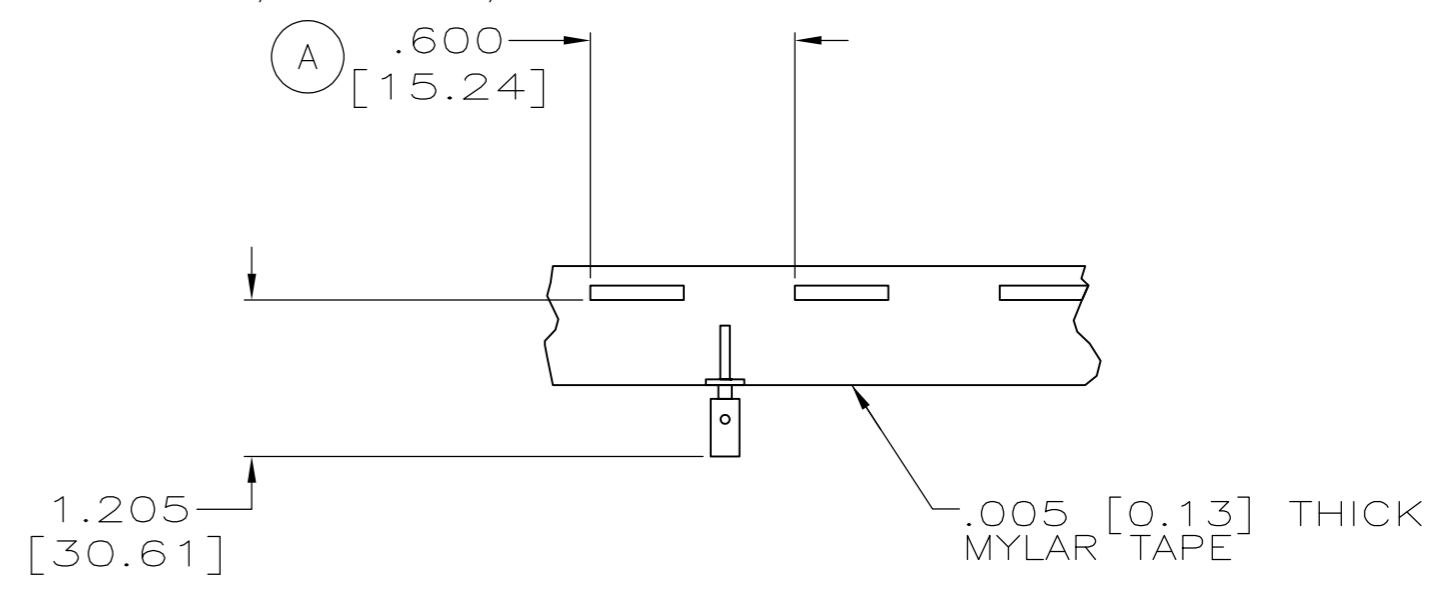

ALTERNATE CONFIGURATION

WHEN ORDERING CONTACT ON TAPE, ORDER BY THE TAPE NUMBER PLUS THE PACKAGEING CODE AS FOLLOWS:

2. FOR USE WITH AMP TAPETRONIC, PNEUMATIC TOOL-  
 A. 1000 PARTS TO A BOX ADD PACKAGING CODE: 1MBOX
3. FOR USE WITH 4/8 INDENT STRIPPER CRIMPER-  
 A. 1000 PARTS TO A REEL ADD PACKAGING CODE: 1MREEL  
 B. 5000 PARTS TO A REEL ADD PACKAGING CODE: 5MREEL

14	WITHOUT COLOR CODE	10	1-204370-4
12	AS SHOWN	9	1-204370-3
12	CONTACTS ON TAPE WITH COLOR CODE	SAME AS -3	1-204370-2
13	WITHOUT COLOR CODE	10	204370-8
12	CONTACTS ON TAPE	SAME AS -2	204370-5
12	AS SHOWN	9	204370-2
14	DESCRIPTION	PLATING	PART NO.

THIS DRAWING IS A CONTROLLED DOCUMENT.		DWN R. RINEHART 10-3-90	<b>STE</b> TE Connectivity	
DIMENSIONS: INCHES		CHK A. EMADI 10-15-90		
TOLERANCES UNLESS OTHERWISE SPECIFIED:		APVD A. EMADI 10-15-90	NAME CONTACT PIN, SIZE 22D	
0 PLC ± -		PRODUCT SPEC	-	
1 PLC ± -		APPLICATION SPEC	-	
2 PLC ± -		SIZE	CAGE CODE	DRAWING NO
3 PLC ± .005		WEIGHT 0.000000	A2 00779	C=204370
4 PLC ± -		CUSTOMER DRAWING	SCALE 10:1	SHEET 1 of 1
ANGLES ± -				REV U
FINISH				