

REVISIONS					
REV	ZONE	ECO	DESCRIPTION	DATE	CHECK
A1	-	-	TECHNICAL DATA SHEET RELEASE	16 OCT 15	JLAG

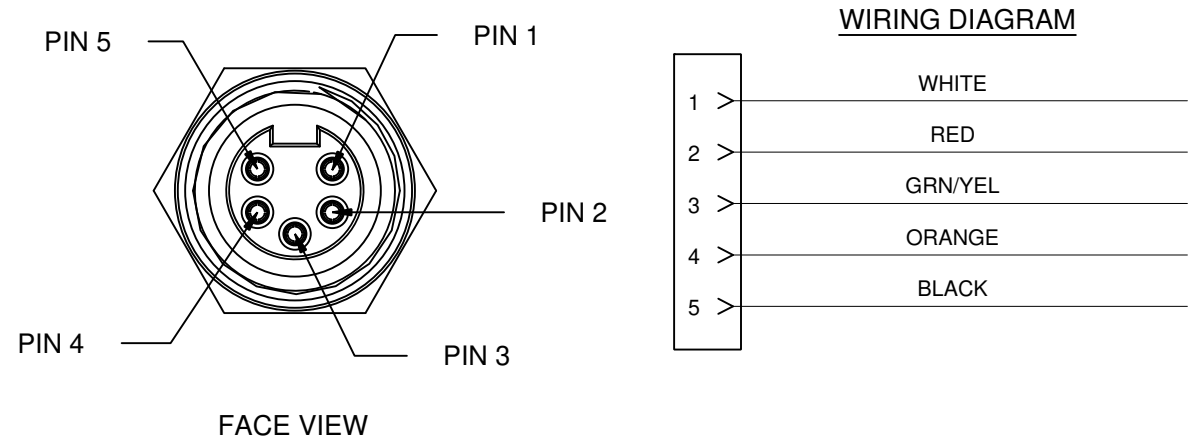
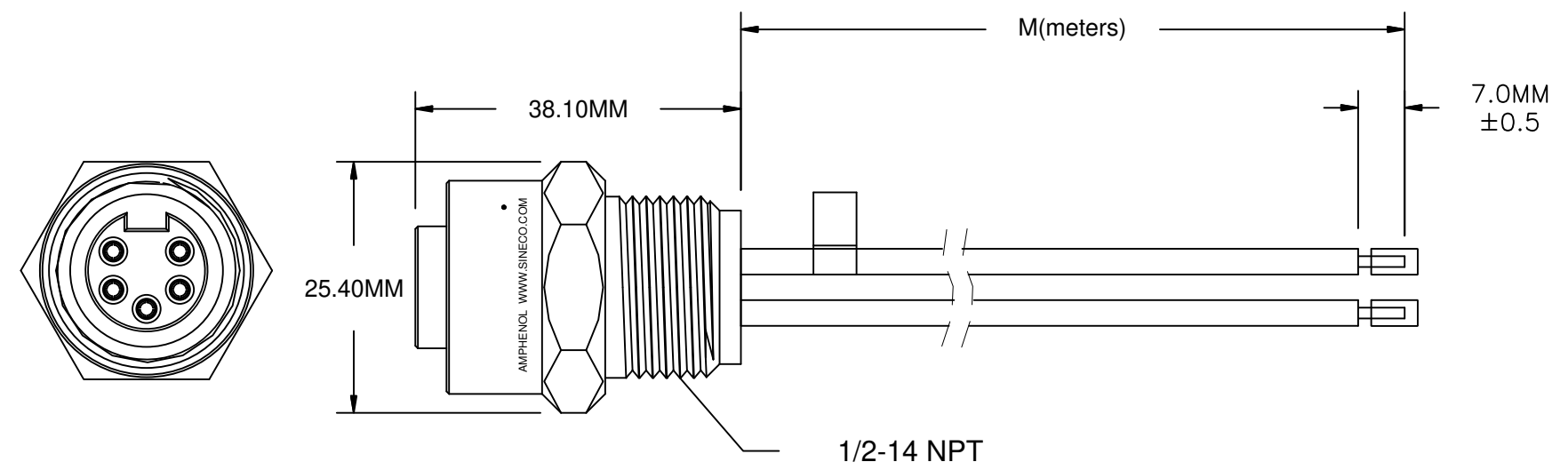

TECHNICAL DATA:

1) MATERIALS:

COUPLING NUT: MACHINED ALUMINUM, ANODIZED
 INSULATION INSERT: THERMOPLASTIC, UL 94/V-0
 CONTACT: GOLD FLASH PLATING OVER COPPER ALLOY
 CABLE RATING: UL LISTED TYPE 1015, CSA CERTIFIED TYPE TEW, FT1 FLAME RATING, 600V, 105°C CABLE JACKET MATERIAL: PVC
 CONDUCTOR INSULATION: PVC
 NUMBER OF CONDUCTORS: (5) 16AWG

2) ELECTRICAL DATA:

CURRENT (MAX): 8A
 VOLTAGE (MAX): 600V AC/DC
 INSULATION RESISTANCE (MIN): 5000M OHMS
 DIELECTRIC TEST VOLTAGE: 2200V

3) MECHANICAL DATA:

TEMPERATURE RANGE: -20°C TO +105°C
 PROTECTION: IP67 (MATED CONDITION)
 MATING CYCLES: >500
 VIBRATION RESISTANCE PER MIL-STD-202 METHOD 204
 THERMAL SHOCK PER MIL-STD-202 METHOD 207
 48 HOUR SALT SPRAY PER MIL-STD-202 METHOD 101

4) RoHS COMPLIANT
 5) UL 2238 LISTED ASSEMBLY
 UL FILE NUMBERS: E224856

Risk of Electrical Shock
Do Not Disconnect Under Load.
Risque de chocs electriques
Ne pas debrancher sous tension.

WARNING

TOLERANCE
0-2.99 M = +100.0/-25.0mm
3-8.99 M = +150.0/-25.0mm
9-14.99 M = +300.0/-25.0mm
15-OVER M = +450.0/-25.0mm

QUANTITY	PART NUMBER	DESCRIPTION	ITEM
MATERIALS LIST			
UNLESS OTHERWISE SPECIFIED		SIGNATURES DATE	
1) All dimensions are in metric(mm).		DRAWN: KMM 12-MAY-14	
2) Tolerances are as follows:		CHECKED: MRF 12-MAY-14	
1 PL DEC ±0.30 Fractions ±1/64		ENGINEER: KMM	
2 PL DEC ±0.15 Angles ±1°		APPROVAL: RFC 12-MAY-14	
3 PL DEC ±0.08		CUSTOMER:	
3) Note reference =		THIS DRAWING IS SUPPLIED FOR INFORMATION ONLY. DESIGN FEATURES, SPECIFICATIONS AND PERFORMANCE DATA SHOWN HEREON ARE THE PROPERTY OF THE AMPHENOL CORPORATION. NO RIGHTS OF REPRODUCTION ARE IMPLIED. ALL DIMENSIONS ARE SUBJECT TO NORMAL MANUFACTURING VARIATIONS.	
MATERIAL SPECIFICATIONS:		MINIBOSS M22 (7/8"), 5 PIN, FEMALE RECEPTACLE, INTERNAL THREADS, 16 AWG, UL1015, PVC WIRE	
PROCESS SPECIFICATIONS:		SIZE: C-	DWG NO: MN54PW02
NEXT ASSY:		SCALE: HALF	REVISION: A1
		C-MN54PW02	SHEET 1 OF 1

TITLE: 5 PIN FEMALE RECEPTACLE
 DATE: 12-MAY-14
 DRAWN: KMM
 CHECKED: MRF
 ENGINEER: KMM
 APPROVAL: RFC