

REVISIONS				
P	LTR	DESCRIPTION	DATE	APVD
23		TRAY DESIGN CHANGE	17JUN2022	SS
24		CORRECT BL WIDTH DIM	20JUN2022	SS
A		RELEASE TO PRODUCTION	23AUG2022	SS
A1		ECR-22-150324	24AUG2022	SS

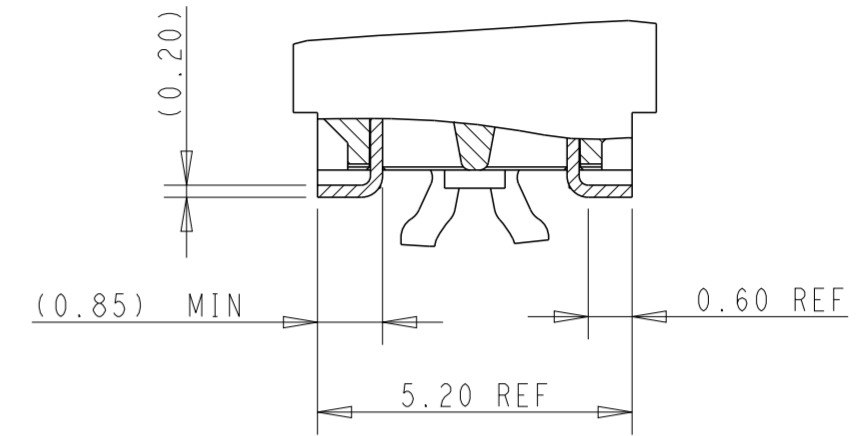

DETAIL D
SCALE 8:1

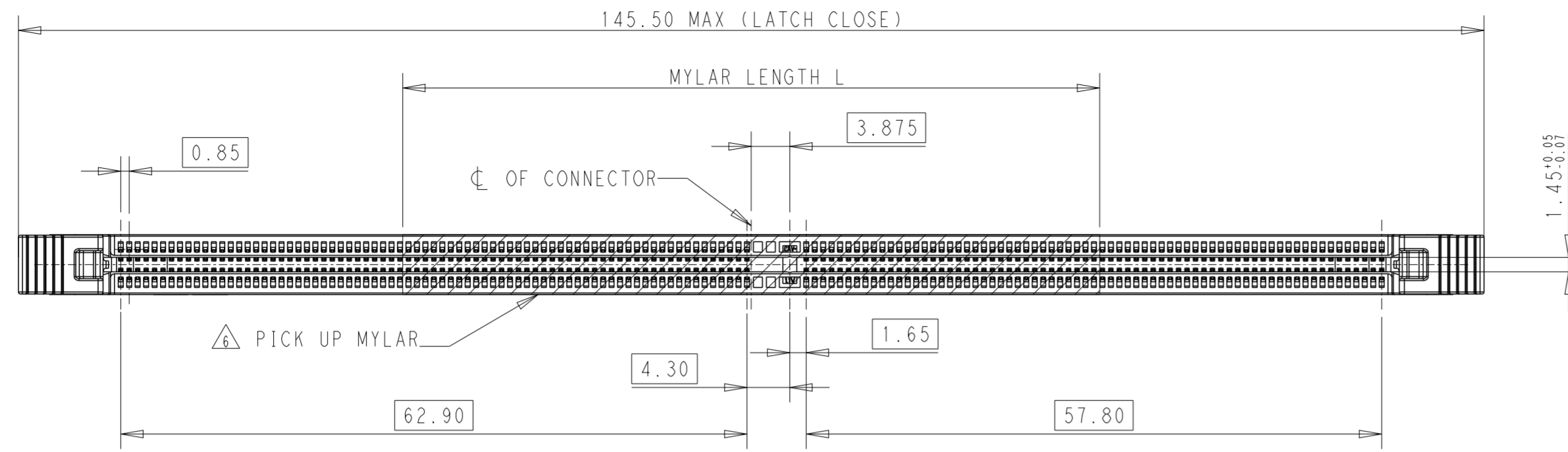
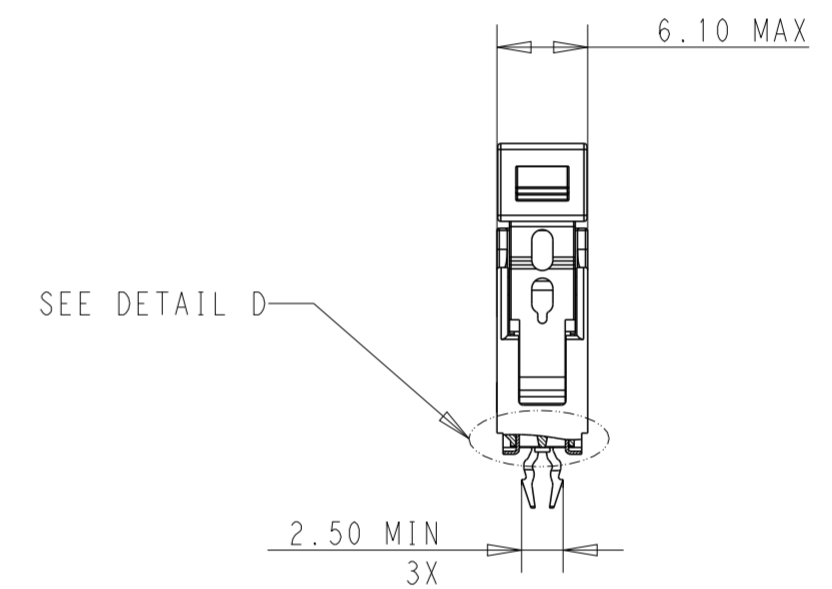
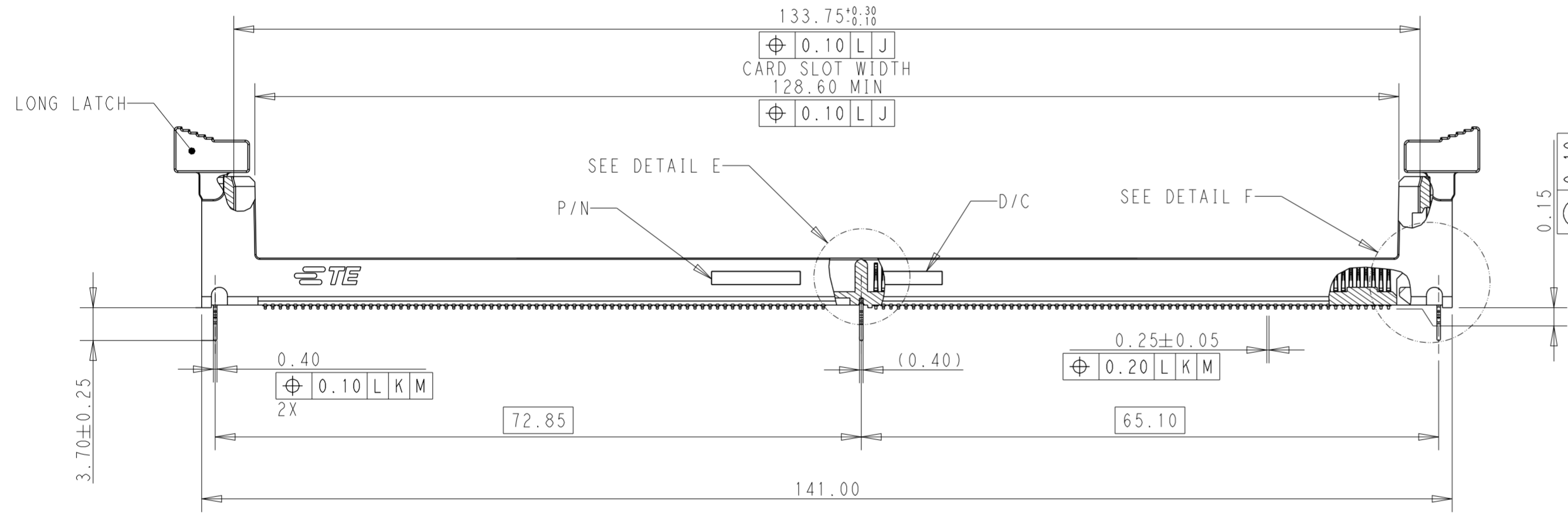

- MATERIALS:
 HOUSING: HIGHT TEMPERATURE NYLON, UL 94-V0,HF;
 LATCHES: HIGHT TEMPERATURE NYLON, UL 94-V0,HF;
 CONTACTS: COPPER ALLOY;
 HOLD DOWN: STAINLESS STEEL.
 - INTERFACE FINISH:
 (1) 0.00076 (30u") MIN THICK GOLD OVER 0.00127 (50u") MIN THICK NICKEL.
 (2) 0.00038 (15u") MIN THICK GOLD OVER 0.00127 (50u") MIN THICK NICKEL.
 - SOLDERTAIL FINISH:
 0.00300 (120u") MIN THICK MATTE TIN OVER 0.00127 (50u") MIN THICK NICKEL.
 - HOLD DOWN FINISH:
 TAB: 0.00300 (120u") MIN THICK MATTE TIN OVER 0.00127 (50u") MIN THICK NICKEL.
 - KEEP OUT AREA RESERVED FOR SOCKET LATCHES AT BOTH ENDS.
- ⚠ MYLAR WITH SIZE L X 6 IS LOCATED IN THE CENTER OF CONNECTOR.

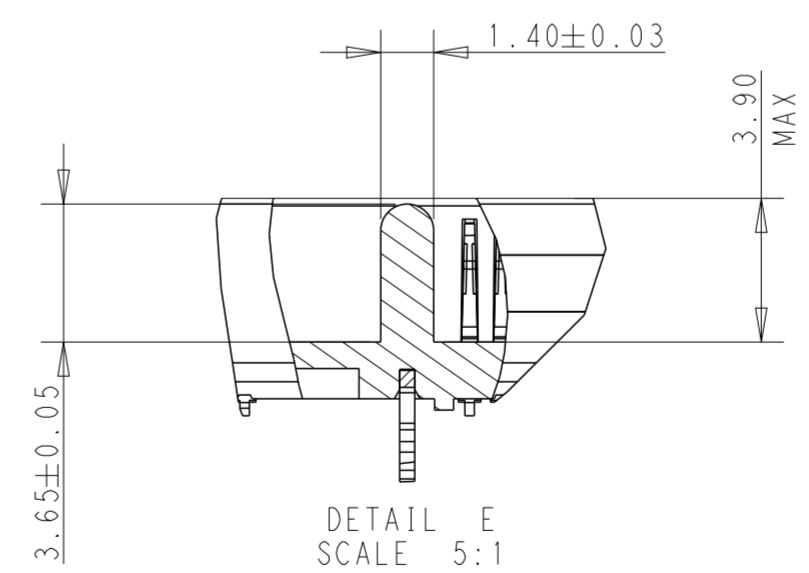

DETAIL E
SCALE 5:1

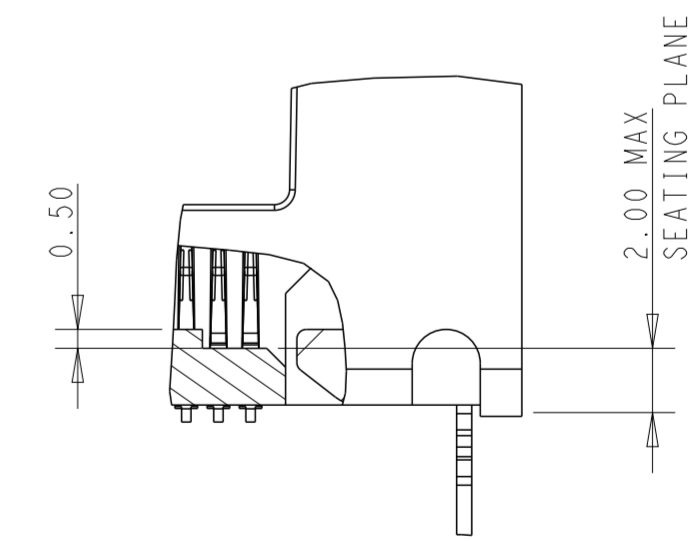

DETAIL F
SCALE 5:1

THIS DRAWING IS A CONTROLLED DOCUMENT.		DWN DAVID ZHAO 22APR2019	TE Connectivity	
DIMENSIONS: mm		CHK -		
TOLERANCES UNLESS OTHERWISE SPECIFIED:		APVD -	NAME SOCKET ASSEMBLY	
0 PLC ±	1 PLC ±0.25	PRODUCT SPEC 108-115141	DDR5 DIMM, SMT TYPE	
2 PLC ±0.15	3 PLC ±0.10	APPLICATION SPEC 114-115044	0.85MM PITCH, 288 POSITION	
4 PLC ±	ANGLES ±2°	WEIGHT -	SIZE A2	CAGE CODE 00779
MATERIAL -	FINISH -	CUSTOMER DRAWING	DRAWING NO C-2355626	RESTRICTED TO -
SCALE 1:1			SHEET 1 OF 6	REV A1

REVISIONS				
P	LTR	DESCRIPTION	DATE	APVD

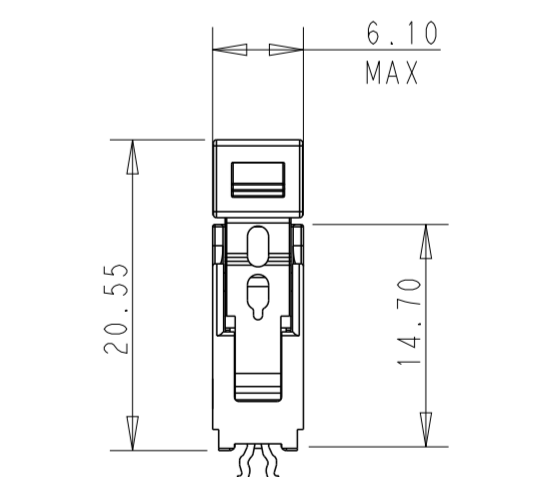
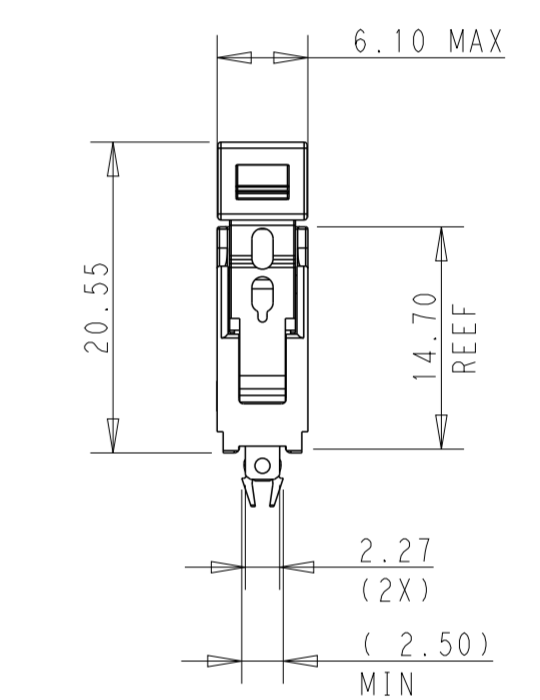
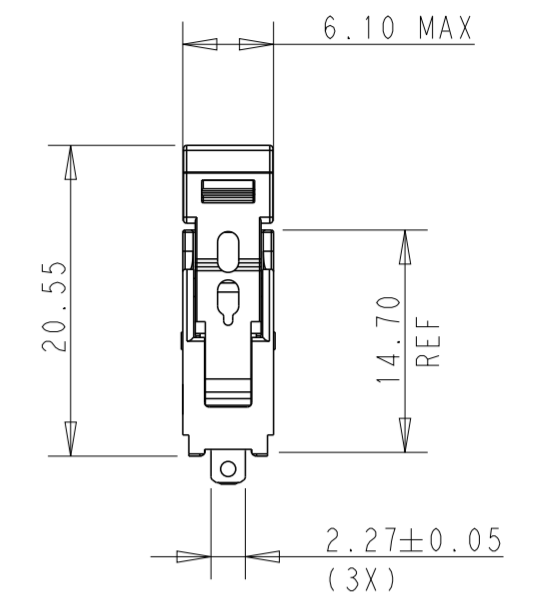
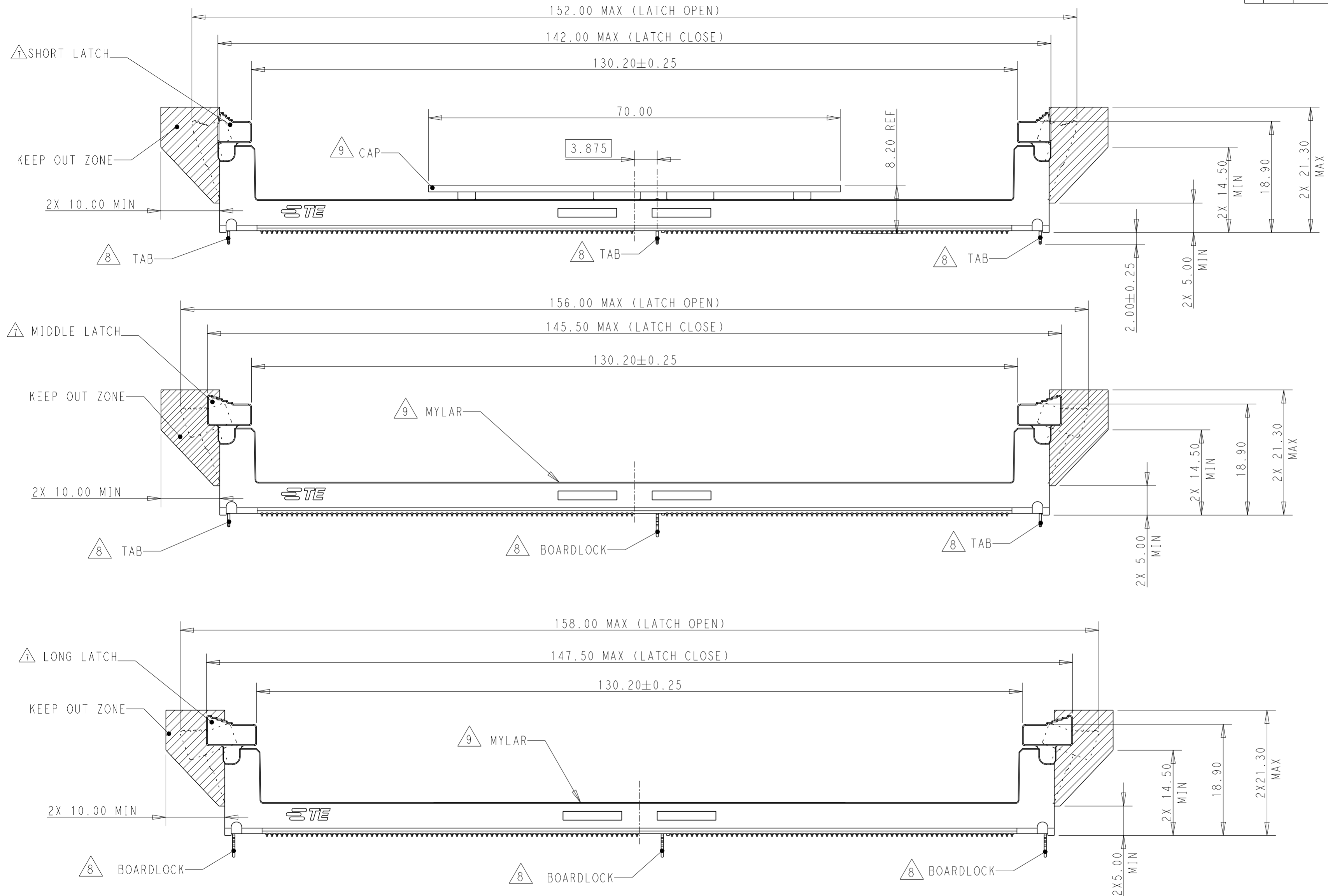

- △ SHORT, LONG, MIDDLE LATCH ARE OPTIONAL FOR DIFFERENT KEEPOUT APPLICATION.
- ⊠ BOARDLOCK AND TAB ARE OPTIONAL FOR DIFFERENT APPLICATION.
- △ MYLAR AND CAP ARE OPTIONAL FOR DIFFERENT APPLICATION.

THIS DRAWING IS A CONTROLLED DOCUMENT.		DWN DAVID ZHAO 22APR2019	TE Connectivity	
DIMENSIONS: mm		CHK -		
TOLERANCES UNLESS OTHERWISE SPECIFIED:		APVD -	NAME SOCKET ASSEMBLY	
0 PLC	±0.25	PRODUCT SPEC	DDR5 DIMM, SMT TYPE	
1 PLC	±0.15	108-115141	0.85MM PITCH, 288 POSITION	
2 PLC	±0.10	APPLICATION SPEC	SIZE	CAGE CODE
3 PLC	±0.10	114-115044	A2	00779
4 PLC	±0.10	WEIGHT	DRAWING NO	RESTRICTED TO
ANGLES	±2°	CUSTOMER DRAWING	G-2355626	-
FINISH	-	SCALE	1:1	SHEET
			2	OF 6
				REV A1

REVISIONS				
P	LTR	DESCRIPTION	DATE	APVD

DDR5 DIMM NAMING RULE

X - 23556XX - X

LATCH TYPE&PICKUP TYPE

- VOID: LONG LATCH & MYLAR 1
- 1: SHORT LATCH & MYLAR 1
- 2: MIDDLE LATCH & MYLAR 1
- 3: LONG LATCH & CAP
- 4: SHORT LATCH & CAP
- 5: MIDDLE LATCH & CAP
- 6: LONG LATCH W/O MYLAR & CAP
- 7: SHORT LATCH W/O MYLAR & CAP
- 8: MIDDLE LATCH W/O MYLAR & CAP
- 9: MIDDLE LATCH & MYLAR 2

HOUSING&LATCH COLOR

- 26: BLACK&BLACK
- 27: BLACK&NATURAL
- 28: BLACK&YELLOW
- 29: BLACK&BLUE
- 30: BLACK&GREEN
- 31: NATURAL&BLACK
- 32: NATURAL&NATURAL
- 33: NATURAL&YELLOW
- 34: NATURAL&BLUE
- 35: NATURAL&GREEN
- 36: YELLOW&BLACK
- 37: YELLOW&NATURAL
- 38: YELLOW&YELLOW
- 39: YELLOW&BLUE
- 40: YELLOW&GREEN
- 41: BLUE&BLACK
- 42: BLUE&NATURAL
- 43: BLUE&YELLOW
- 44: BLUE&BLUE
- 45: BLUE&GREEN
- 46: GREEN&BLACK
- 47: GREEN&NATURAL
- 48: GREEN&YELLOW
- 49: GREEN&BLUE
- 50: GREEN&GREEN

GOLD PLATING&HOLDDOWN TYPE

- 1: 30u" & 3 TAB
- 2: 30u" & 3 BOARDLOCK
- 3: 30u" & 2 SIDETAB+1 BOARDLOCK
- 4: 15u" & 3 TAB
- 5: 15u" & 3 BOARDLOCK
- 6: 15u" & 2 SIDETAB+1 BOARDLOCK

DDR5 DIMM SPEC CHARACTERISTICS (MORE SPEC,CHECK TE 108-115141)

1. MECHANICAL CHARACTERISTICS

- 1.1 INSERTION FORCE OF MODULE TO CONNENTOR: 106.8N MAX.
- 1.2 UNMATING FORCE: 19.77N MIN.
- 1.3 DURABILITY: PERFORM 25 CYCLES MATING AND UNMATING.
- 1.4 INSERTION FORCE OF CONNECTOR TO PCB: 35N MAX.

2. ELECTRICAL CHARACTERISTICS

- 1.1 WITHSTANDING VOLTAGE: 500VAC PER EIA-364-20, CONDITION I.
- 1.2 INSULATION RESISTANCE: 1M OHMS MIN PER EIA-364-21, 500VDC.
- 1.3 CURRENT CARRYING CAPABILITY AT 30°C TEMPERATURE: 1A MAX.
- 1.4 CONTACT RESISTANCE(LLCR):
 INITIAL: 20 MILLIOHMS MAX,
 FINAL: THE CHANGE IN LLCR BETWEEN THE READING AFTER STRESS AND THE INITIAL READING SHALL NOT EXCEED 20 MILLIOHMS.

3. ENVIRONMENTAL CHARACTERISTICS

- 1.1 TEMPERATURE LIFE: 105°C, 120H PER EIA-364-17, METHOD A.
- 1.2 MECHANICAL SHOCK: 50G, 11MILLISECONDS, 3 DROPS IN EACH OF 6 DIRECTIONS PER EIA-364-27.
- 1.3 VIBRATION: 10 MINUTES PER DIRECTION FOR ALL 3 DIRECTIONS PER EIA-364-28, PROFILE SEE TE 108-115141.
- 1.4 THERMAL SHOCK: -55°C TO 85°C, 5 CYCLES IN MATED CONDITION PER EIA-364-32, METHOD A, CONDITON I.
- 1.5 CYCLIC TEMPERATUREHUMILITY: 24 CYCLES BETWEEN 25°C AT 80% RH AND 65°C AT 50% RH PER EIA-364-31, METHOD III.
- 1.6 THERMAL CYCLING: 500 CYCLES IN MATED CONDITION BETWEEN 15°C AND 85°C.
- 1.7 MIXED FLOWING GAS:
 FOR 15U"AU TYPE, 168H MIN TESTING PER EIA-364-65, CLASS IIA.
 FOR 30U"AU TYPE, 240H MIN TESTING PER EIA-364-65, CLASS IIA.

4. REFLOW PROCESS CHARACTERISTICS

MOISTURE SENSITIVITY LEVEL OF PLASTIC MATERIAL IS LEVEL 1, COULD WITHSTAND 260°C, 10S LEAD FREE PROCESS ABILITY. RECOMMENDED REFLOW PROFILE IS IN TE 108-115141.

NOTE:

MYLAR 1 LENGTH: L=70.0 ±1.0
 MYLAR 2 LENGTH: L=128.0 ±1.0

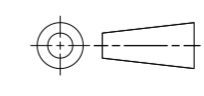
THIS DRAWING IS A CONTROLLED DOCUMENT.		DWN DAVID ZHAO 22APR2019	 TE Connectivity	
DIMENSIONS: mm		CHK -		
		TOLERANCES UNLESS OTHERWISE SPECIFIED:		NAME SOCKET ASSEMBLY DDR5 DIMM, SMT TYPE 0.85MM PITCH, 288 POSITION
MATERIAL -		0 PLC ± 1 PLC ±0.25 2 PLC ±0.15 3 PLC ±0.10 4 PLC ± ANGLES ±2° FINISH	PRODUCT SPEC 108-115141	SIZE A2
			APPLICATION SPEC 114-115044	CAGE CODE 00779
			WEIGHT -	DRAWING NO C-2355626
			CUSTOMER DRAWING	RESTRICTED TO -
			SCALE 1:1	SHEET 3 OF 6
				REV A1

REVISIONS				
P	LTR	DESCRIPTION	DATE	APVD

1 DATUM Z IS THE TOP SIZE OF PCB.
 2 HOLD DOWN HOLE SHOULD BE PLATED THROUGH HOLE.

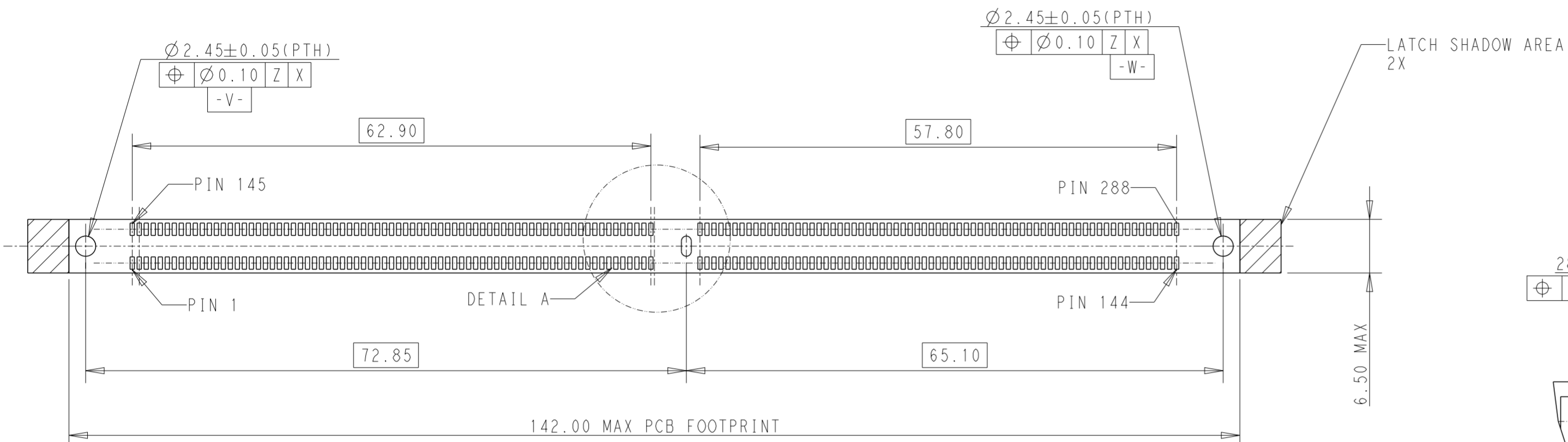

FOR SHORT LATCH, X IS 152MM MAX;
 FOR MIDDLE LATCH, X IS 156MM MAX;
 FOR LONG LATCH, X IS 162MM MAX;

OPTION 1

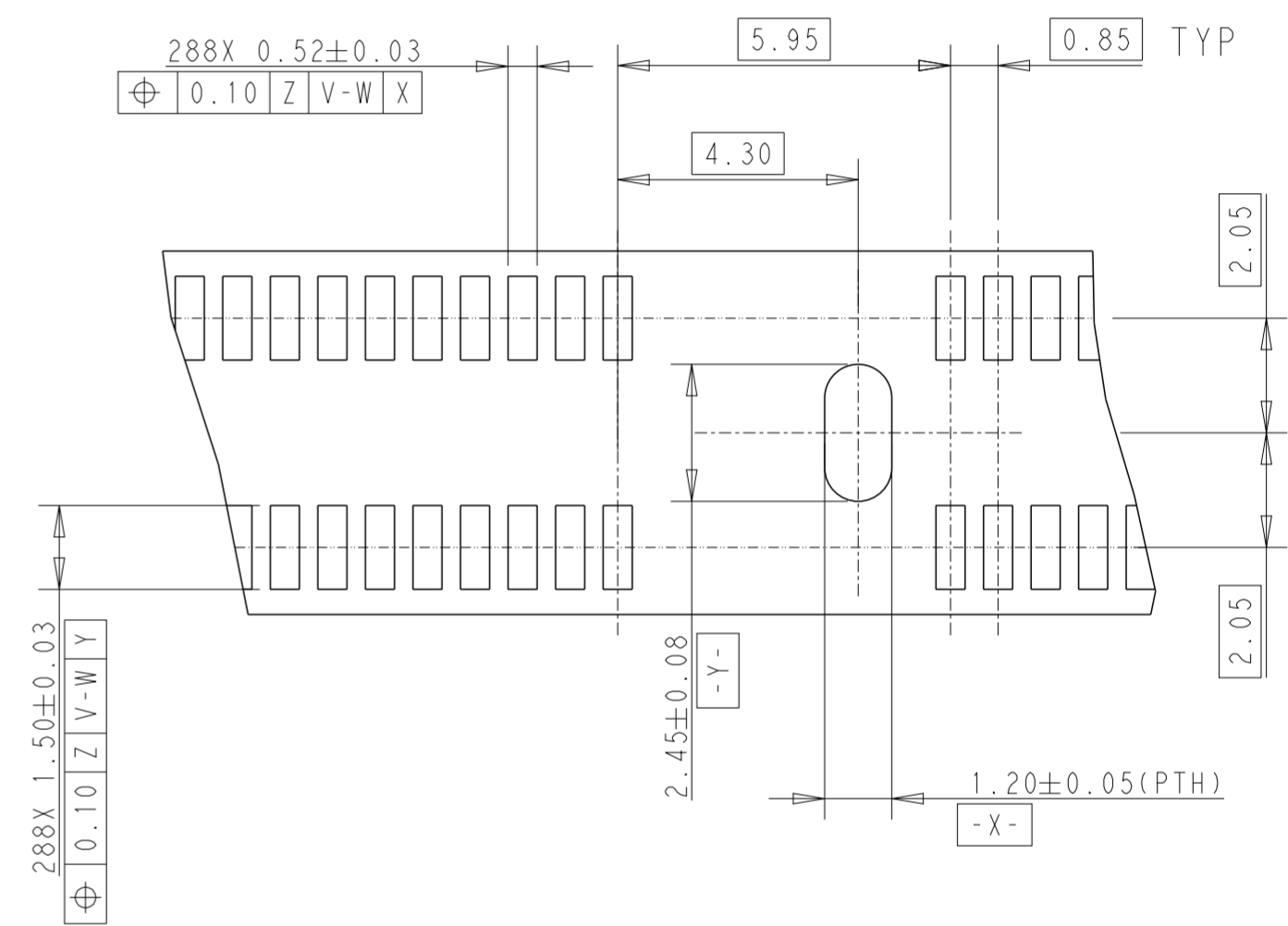

DETAIL A
 SCALE 8:1

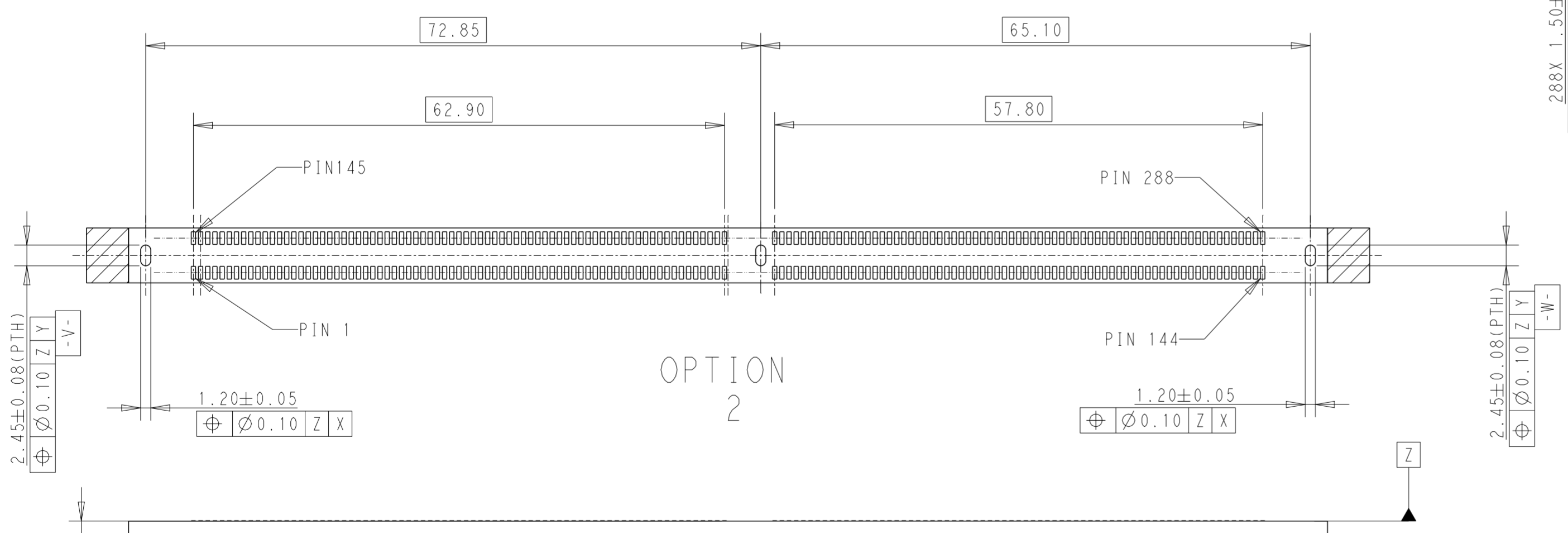

OPTION 2

RECOMMENDED PCB LAYOUT
 VIEWED FROM CONNECTOR SIDE

THIS DRAWING IS A CONTROLLED DOCUMENT.		DWN 22APR2019 DAVID ZHAO	TE Connectivity	
DIMENSIONS: mm		CHK -		
TOLERANCES UNLESS OTHERWISE SPECIFIED:		APVD -	NAME SOCKET ASSEMBLY DDR5 DIMM, SMT TYPE 0.85MM PITCH, 288 POSITION	
0 PLC ±		PRODUCT SPEC 108-115141	SIZE CAGE CODE DRAWING NO	
1 PLC ±0.25		APPLICATION SPEC 114-115044	RESTRICTED TO	
2 PLC ±0.15		WEIGHT -	A2100779 C-2355626	
3 PLC ±0.10		CUSTOMER DRAWING	SCALE 1:1 SHEET 4 OF 6 REV A1	
4 PLC ±				
ANGLES ±2°				
FINISH -				

THIS DRAWING IS UNPUBLISHED. RELEASED FOR PUBLICATION 20
 © COPYRIGHT 2022 TE Connectivity. All Rights Reserved. ALL RIGHTS RESERVED.

REVISIONS				
P	LTR	DESCRIPTION	DATE	APVD

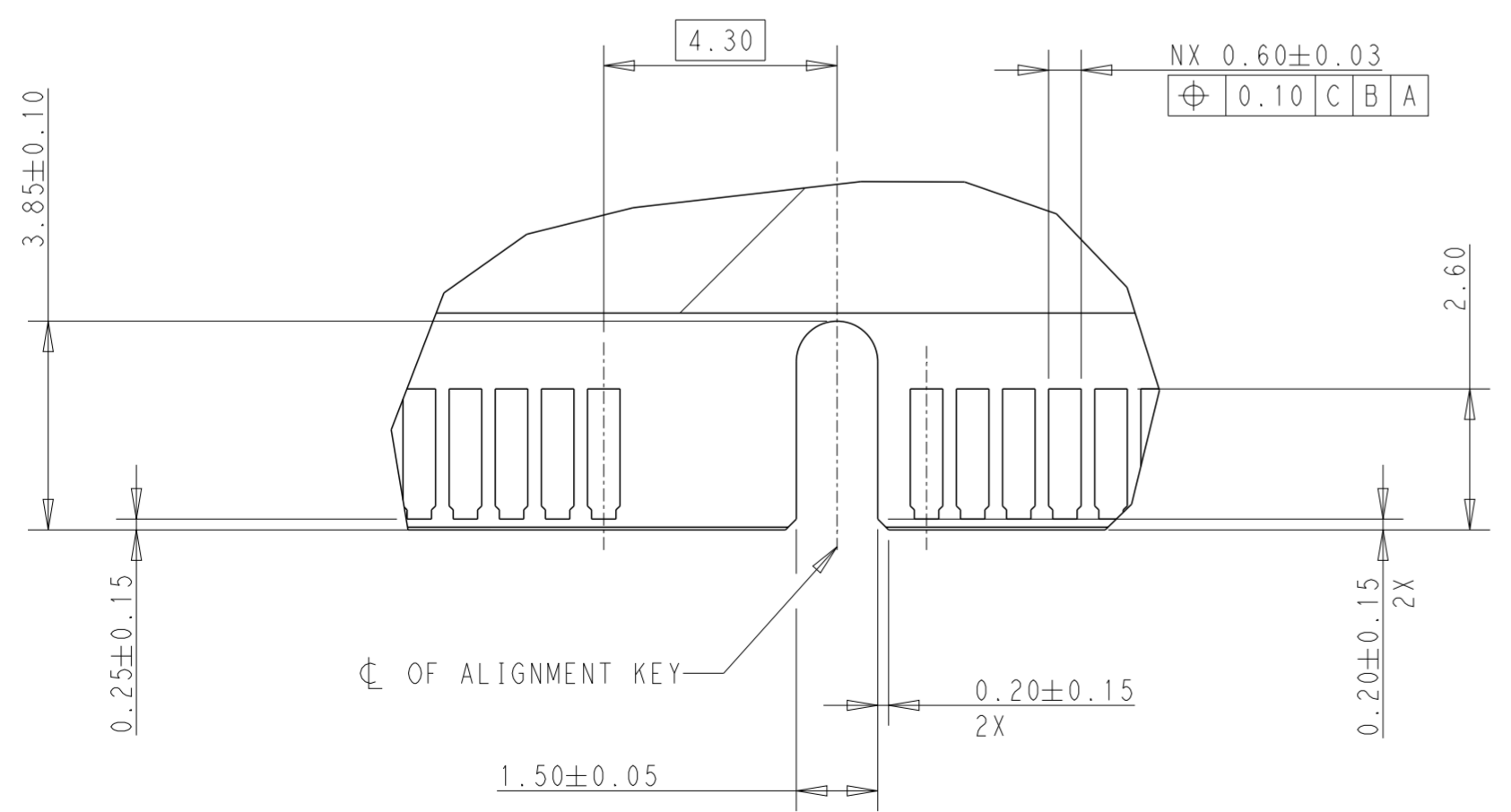
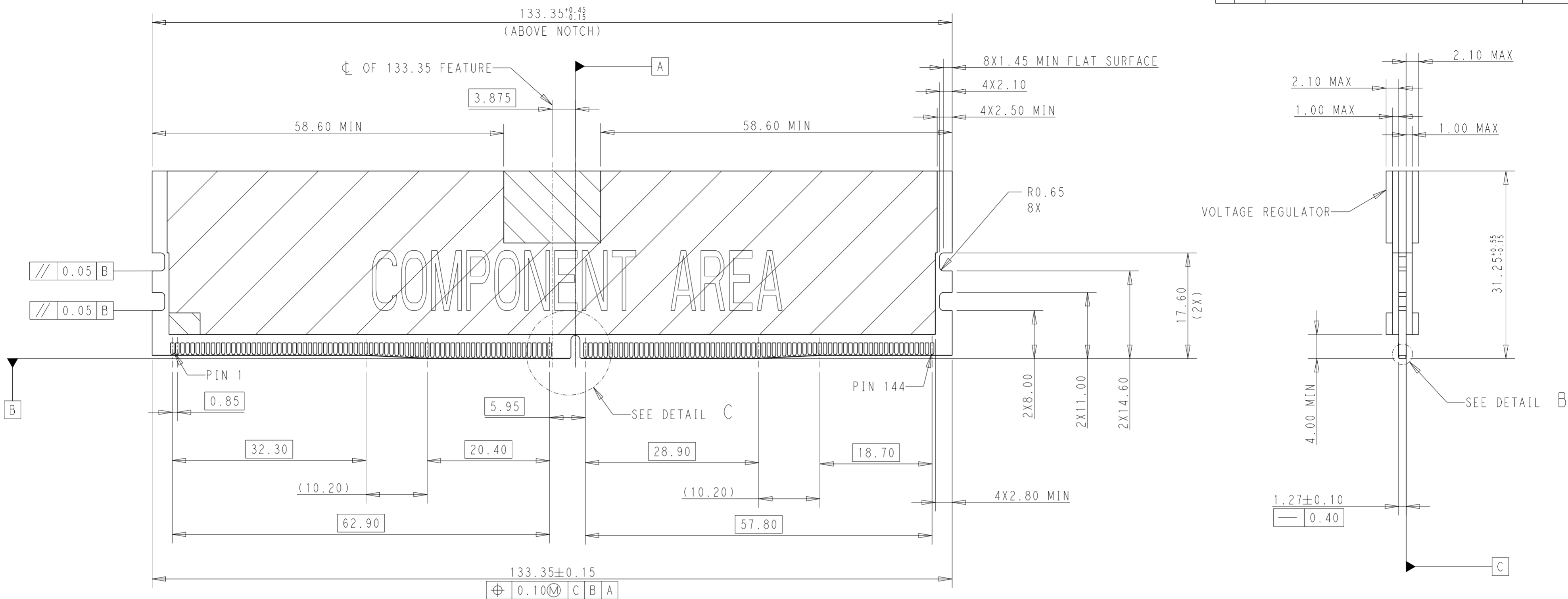

DETAIL C
 SCALE 8:1

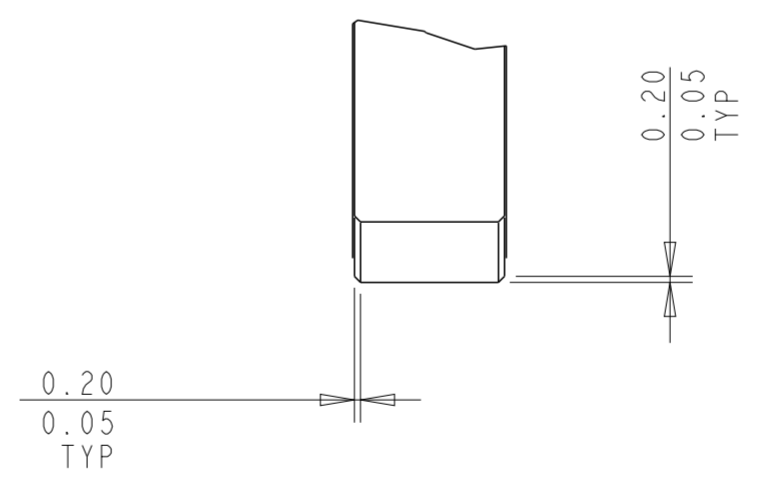

DETAIL B
 SCALE 16:1

THIS DRAWING IS A CONTROLLED DOCUMENT.		DWN DAVID ZHAO 22APR2019	TE Connectivity	
DIMENSIONS: mm		CHK -		
TOLERANCES UNLESS OTHERWISE SPECIFIED:		PRODUCT SPEC 108-115141		NAME SOCKET ASSEMBLY DDR5 DIMM, SMT TYPE 0.85MM PITCH, 288 POSITION
0 PLC ±		APPLICATION SPEC 114-115044		SIZE A2
1 PLC ±0.25		DRAWING NO C-2355626		CAGE CODE 00779
2 PLC ±0.15		WEIGHT -		DRAWING NO C-2355626
3 PLC ±0.10		CUSTOMER DRAWING		RESTRICTED TO -
4 PLC ±		SCALE 1:1		SHEET 5 OF 6
ANGLES ±2°		REV A1		
FINISH -				

P	LTR	DESCRIPTION	DATE	DWN	APVD

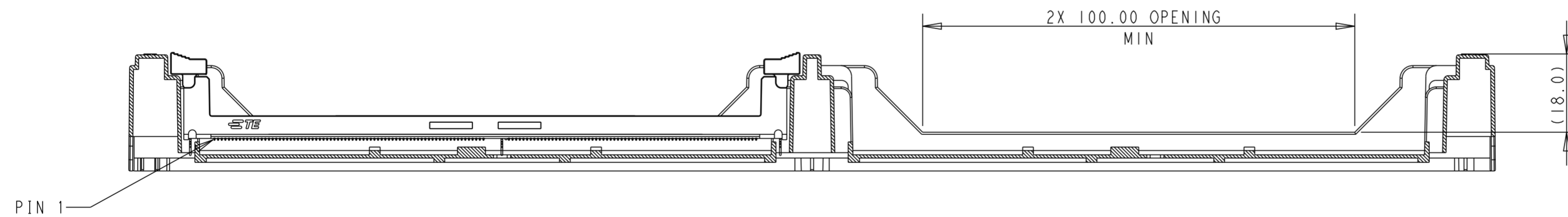
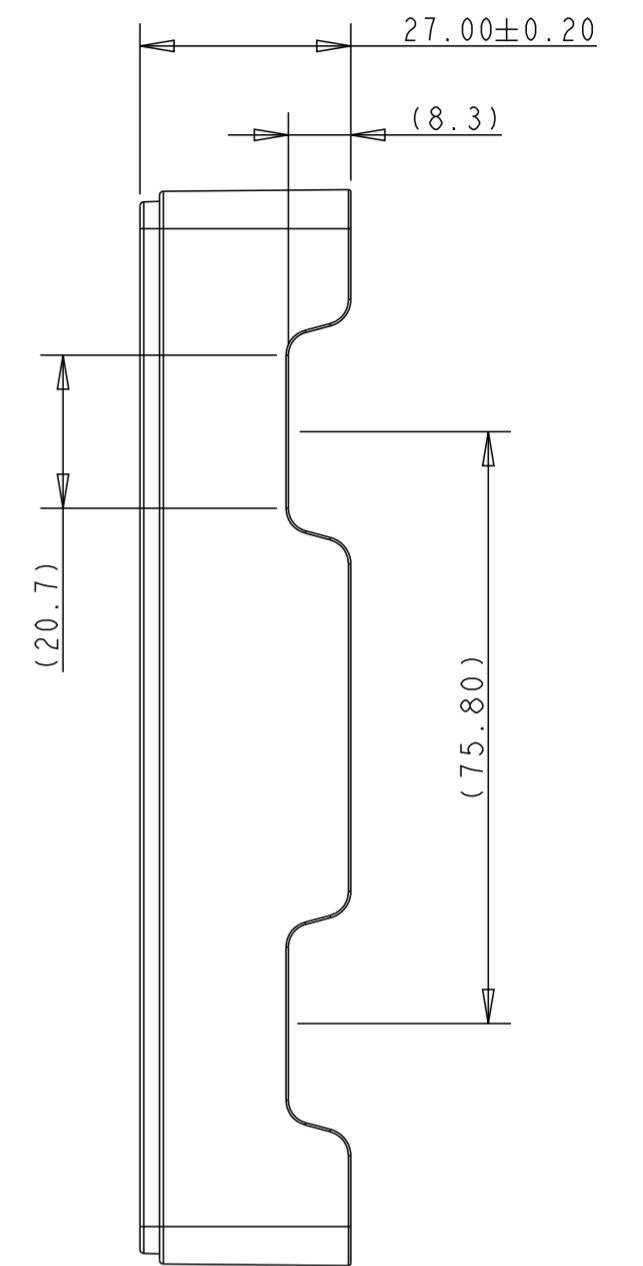
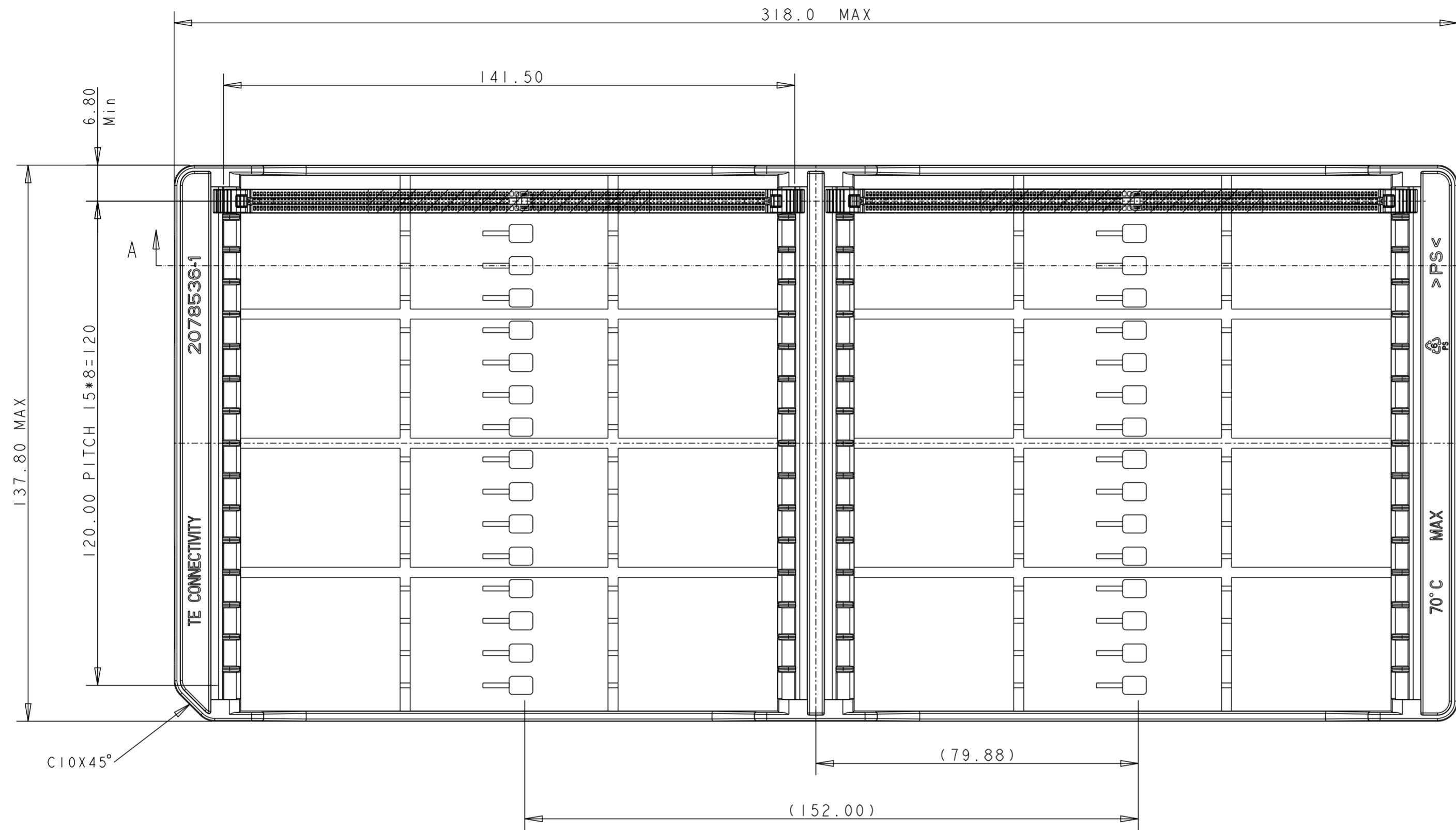

SECTION A-A

NOTES:

- MATERIALS :
TRAY: HIPS, COLOR: BLACK
BOX: CORRUGATED FIBERBOARD
- DIMENSIONS:
BOX: L=410;W=383;H=340
- QUANTITY:
32 PCS/TRAY
640 PCS/BOX
- WEIGHT:
GROSS WEIGHT: 7.5KG

THIS DRAWING IS A CONTROLLED DOCUMENT.		DWN DAVID ZHAO	22APR2019	TE Connectivity	
DIMENSIONS: mm		CHK -	APVD -		
TOLERANCES UNLESS OTHERWISE SPECIFIED: 0 PLC ± 1 PLC ±0.25 2 PLC ±0.15 3 PLC ±0.10 4 PLC ± ANGLES ±2° FINISH -		PRODUCT SPEC 108-115141	APPLICATION SPEC 114-115044	NAME SOCKET ASSEMBLY DDR5 DIMM, SMT TYPE 0.85MM PITCH, 288 POSITION	
MATERIAL -		WEIGHT -	CUSTOMER DRAWING	SIZE A2	RESTRICTED TO -
		SCALE 1:1		SHEET 6 OF 6	REV A1