

Evaluation Board for the **ADP1876** Step-Down DC-to-DC Controller

FEATURES

- Input range: 10 V to 20 V**
- Two output voltages: 5 V and 1.8 V**
- Output current: 13 A per channel**
- Switching frequency: 600 kHz**
- Operates in PWM**
- Compact, low cost, and efficient design**

EVALUATION BOARD DESCRIPTION

This user guide describes the design, operation, and test results of the ADP1876-EVALZ. The input range for this evaluation board is 10 V to 20 V, and the two regulated output voltages are set to 5 V (V_{OUT1}) and 1.8 V (V_{OUT2}) with a maximum 13 A output current. The power components, such as the MOSFETS, inductors, and bulk input and output capacitors, were chosen to yield a low system cost and good efficiency.

ADP1876 DEVICE DESCRIPTION

The **ADP1876** is a dual-channel, step-down switching controller with integrated drivers for external N-channel synchronous power MOSFETs. The two PWM outputs are phase shifted 180°, which reduces the input rms ripple current, thus minimizing the required input capacitance.

In addition, boost diodes are integrated into the **ADP1876**, which lowers the overall system cost and component count. The **ADP1876** is configured to operate in forced PWM continuous conduction mode.

The **ADP1876** includes externally adjustable soft start, output overvoltage protection, externally adjustable current limit, power good and tracking function for Channel 1. The **ADP1876** provides an output voltage accuracy of $\pm 0.85\%$ for a -40°C to $+85^{\circ}\text{C}$ junction temperature and $\pm 1.5\%$ for a -40°C to $+125^{\circ}\text{C}$ junction temperature. This controller can be powered from a 2.75 V to 20 V supply and is available in a 32-lead, 5 mm \times 5 mm lead frame chip scale package (LFCSP).

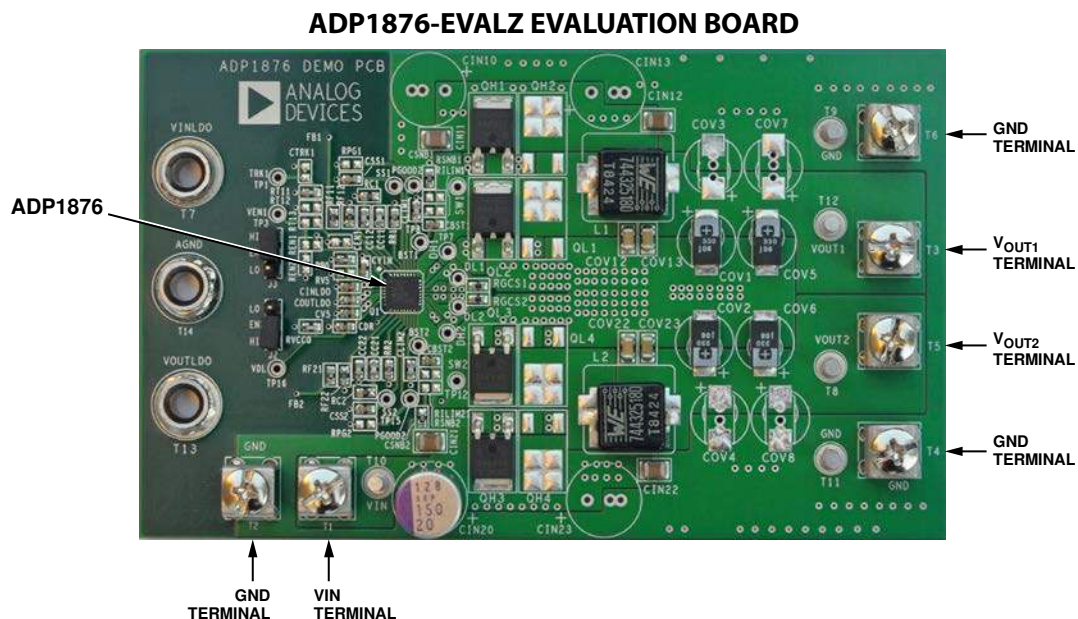

Figure 1.

10272-001

TABLE OF CONTENTS

Features	1	Output Capacitors	3
Evaluation Board Description.....	1	MOSFET Selection.....	3
ADP1876 Device Description.....	1	Test Results	4
ADP1876-EVALZ Evaluation Board.....	1	Evaluation Board Operating Instructions.....	6
Revision History	2	Evaluation Board PCB Layout	7
Component Design	3	Evaluation Board Schematics and Artwork	8
Inductor Selection	3	Ordering Information.....	12
Input Capacitors	3	Bill of Materials.....	12

REVISION HISTORY

11/11—Revision 0: Initial Version

COMPONENT DESIGN

For information about selecting power components and calculating component values, see the [ADP1876](#) data sheet.

INDUCTOR SELECTION

A 1.8 μH inductor with an 18 A saturation current rating (744325180 from Würth Elektronik) is selected. This is a compact inductor with a ferrite core, which offers high performance in terms of low R_{DC} and low core loss.

INPUT CAPACITORS

Because of the very low ESR and high input current rating of multilayer ceramic capacitors (MLCCs), two 10 μF MLCCs in Size 1210 are selected as the input capacitors at the input of each channel. In addition, a 150 μF bulk OS-CON™ (aluminum solid capacitor with conductive polymer) capacitor from SANYO is chosen for filtering out unwanted low frequency noise from the input power supply.

OUTPUT CAPACITORS

A combination of POSCAP™ polymer capacitors and MLCCs are selected for the output rails. Polymer capacitors have low ESR and high current ripple rating. Connecting polymer capacitors and MLCCs in parallel is very effective in reducing voltage ripple. Two 330 μF POSCAP capacitors and two 22 μF MLCCs are selected for each output.

MOSFET SELECTION

For low output or low duty cycle, select a high-side MOSFET with fast rise and fall times and with low input capacitance to minimize charging and switching power loss. For the synchronous rectifier (low-side MOSFET), select a MOSFET with low $R_{\text{DS(on)}}$ because the switching speed is not critical and there is no switching power loss in the low-side MOSFET.

The MOSFET IPD050N03L in PG-TO252-3-11 (DPAK) from Infineon is chosen for both the high-side and low-side MOSFETs for a balance between low cost and good efficiency. The $R_{\text{DS(on)}}$ of the IPD050N03L is about 6 $\text{m}\Omega$ at a V_{GS} of 5 V.

TEST RESULTS

$T_A = 25^\circ\text{C}$.

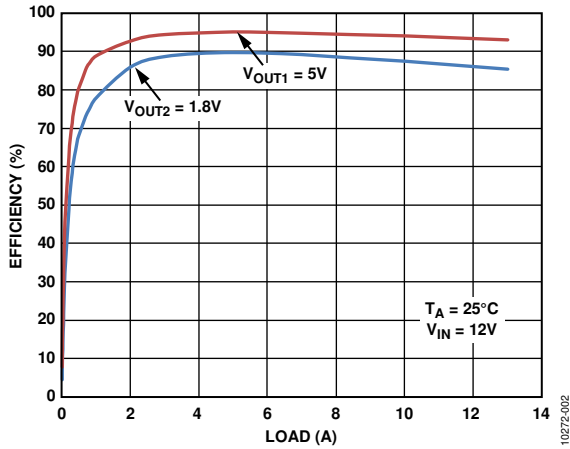

Figure 2. Efficiency (Measurement Is Made with the Adjacent Channel Disabled)

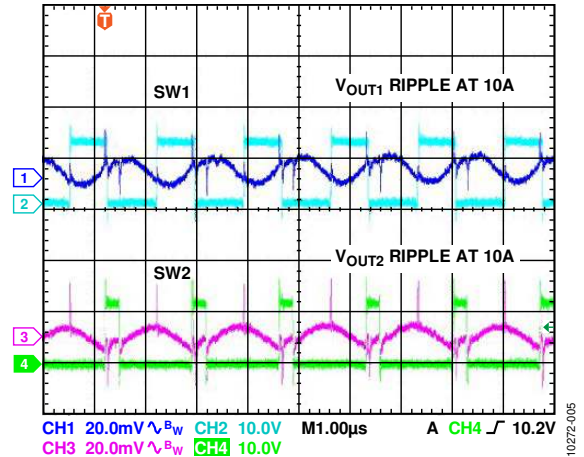

Figure 5. Output Ripple, 10 A Load

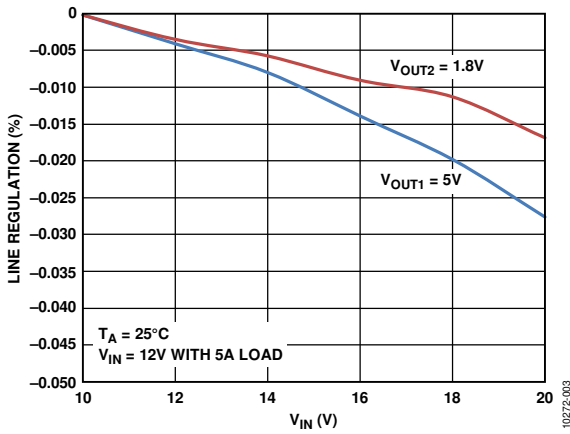

Figure 3. Line Regulation

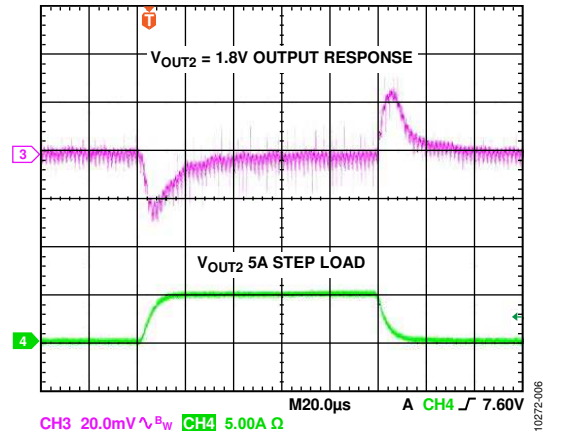

Figure 6. Step Load Transient, V_{OUT2}

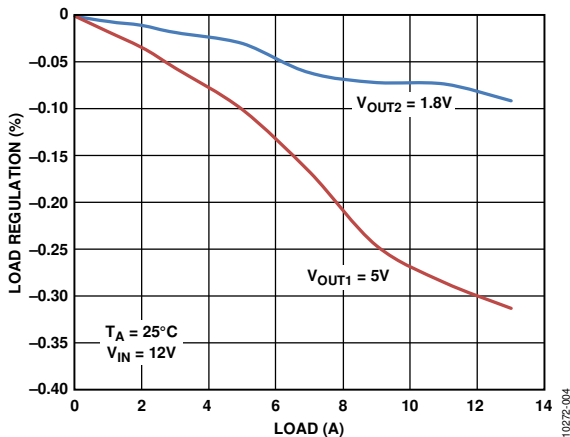

Figure 4. Load Regulation

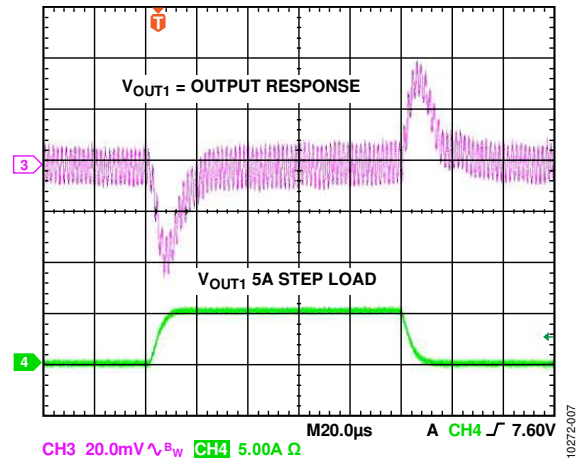

Figure 7. Step Load Transient, V_{OUT1}

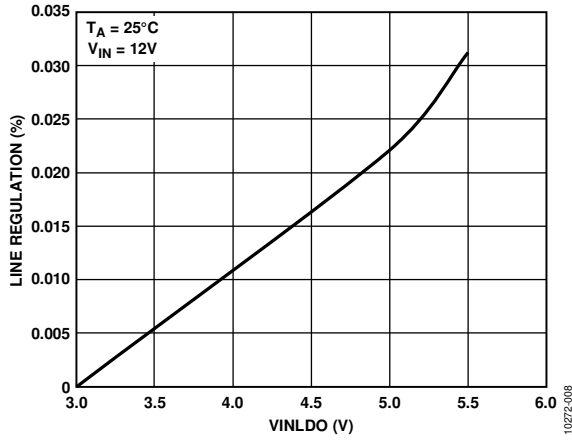

Figure 8. VOUTLDO Line Regulation

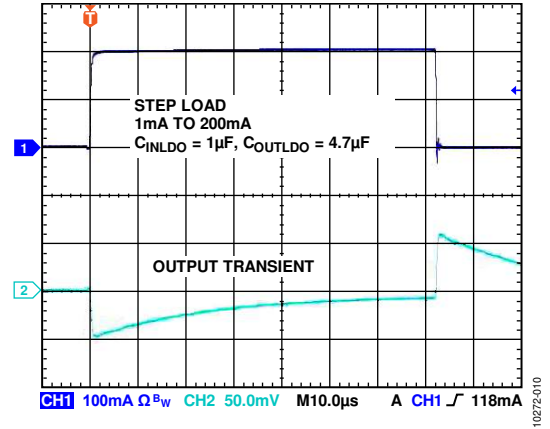

Figure 10. VOUTLDO Step Load Response

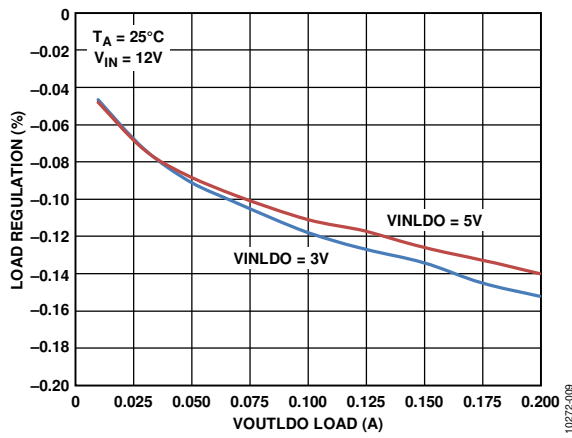

Figure 9. VOUTLDO Load Regulation

EVALUATION BOARD OPERATING INSTRUCTIONS

1. Connect Jumper J3 (EN1) to the high position to enable Channel 1 of the ADP1876.
2. Connect Jumper J2 (EN2) to the high position to enable Channel 2 of the [ADP1876](#).
3. Connect the positive terminal of the input power supply to the T1 input terminal. The input range is 10 V to 20 V, which powers up the [ADP1876](#) IC.
4. Connect the positive terminal of another input power supply to the T7 input terminal (VINLDO). The input range is 2.7 V to 5.5 V, which powers up the independent LDO.

Table 1. Jumper Description

Jumper	Description	Default Factory Setting	Function
J3	EN1	High	Connect high to enable Channel 1 of the ADP1876 , or connect low to disable the channel.
J2	EN2	High	Connect high to enable Channel 2 of the ADP1876 , or connect low to disable the channel.

Table 2. Performance Summary ($T_A = 25^\circ\text{C}$)

Parameter	Condition
V_{IN}	10 V to 20 V
f_{SW}	Switching frequency, 600 kHz
V_{OUT1}	5 V
I_{OUT1}	0 A to 13 A
V_{OUT1} Ripple, DC Load	12 mV at 13 A load
V_{OUT1} Deviation upon Step Load Release	0.8% with a 5 A step load
V_{OUT2}	1.8 V
I_{OUT2}	0 A to 13 A
V_{OUT2} Ripple, DC Load	12 mV at 13 A load
V_{OUT2} Deviation upon Step Load Release	1.4% with a 5 A step load

EVALUATION BOARD PCB LAYOUT

As seen in Figure 1, the layout of this evaluation board is not optimized for the smallest PCB area. It is laid out in such a way that any of the components can be desoldered and replaced easily with different components with a hand soldering iron so that the user can modify the existing design without acquiring a new PCB layout. The physical size of the compensation components is 0603, which is selected for its ease of hand soldering when reworking the board is needed. The size of these components can be 0402 or even smaller in the final design. Note that there are extra placeholders for input bulk capacitors, output filter capacitors, and MOSFETs. The user can remove, add, or change any of these power components to achieve a particular design objective. The track function, where TRK1 is pulled up to VCCO through a 0 Ω dummy

resistor, is not used on this evaluation board. The primary purpose of the TRK1 function is to discharge VOUT1 to GND quickly when EN1 is pulled low and not relying on the feedback resistors for discharging the output. To achieve a fast discharging on the output, put an RC time delay at EN1 and a smaller RC time delay at TRK1. Placeholders for these RC components have been included on the evaluation board (see Figure 11 for details).

In addition, dummy 0 Ω resistors are placed at the driver gates, DHx and DLx, for evaluation purposes only and can be removed in the final design. Furthermore, many test points are placed on the evaluation board so that the user can easily evaluate the performances of the [ADP1876](#) with an oscilloscope. See Figure 11, the evaluation board schematic, for more information.

EVALUATION BOARD SCHEMATICS AND ARTWORK

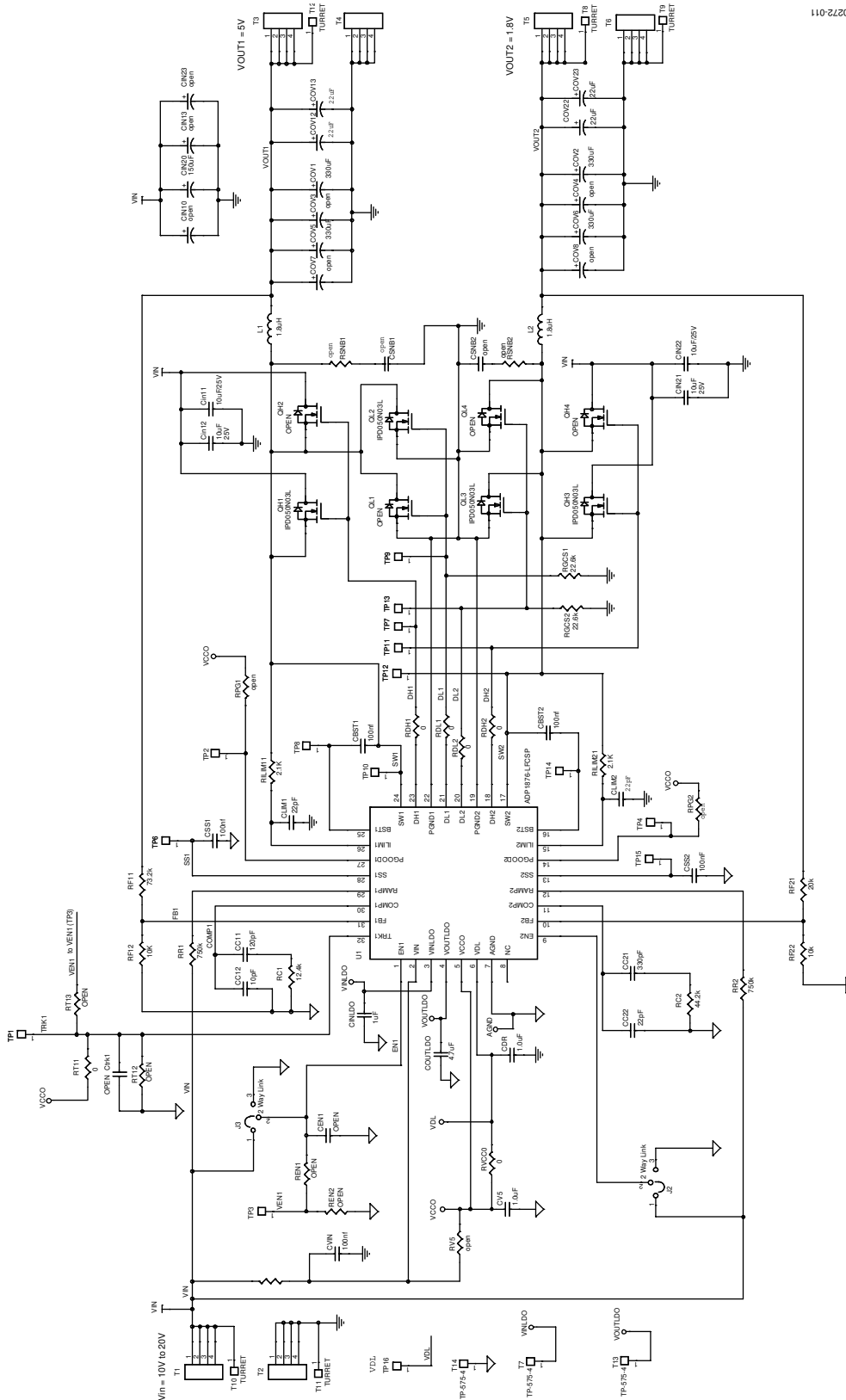

10272-011

Figure 11. Evaluation Board Schematic

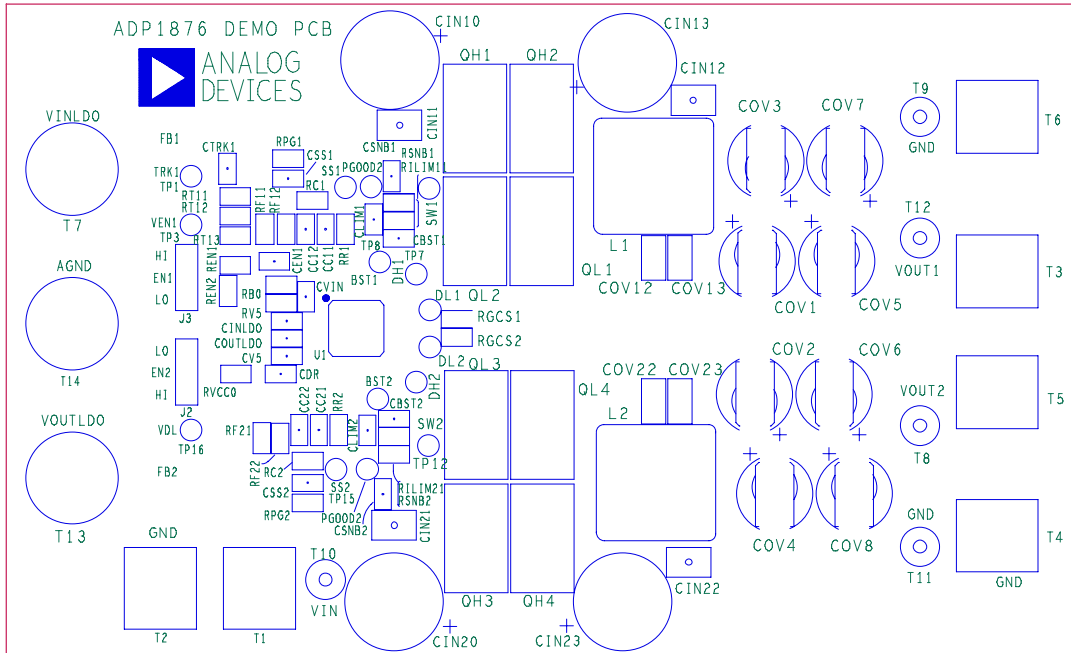

Figure 12. Top Silkscreen

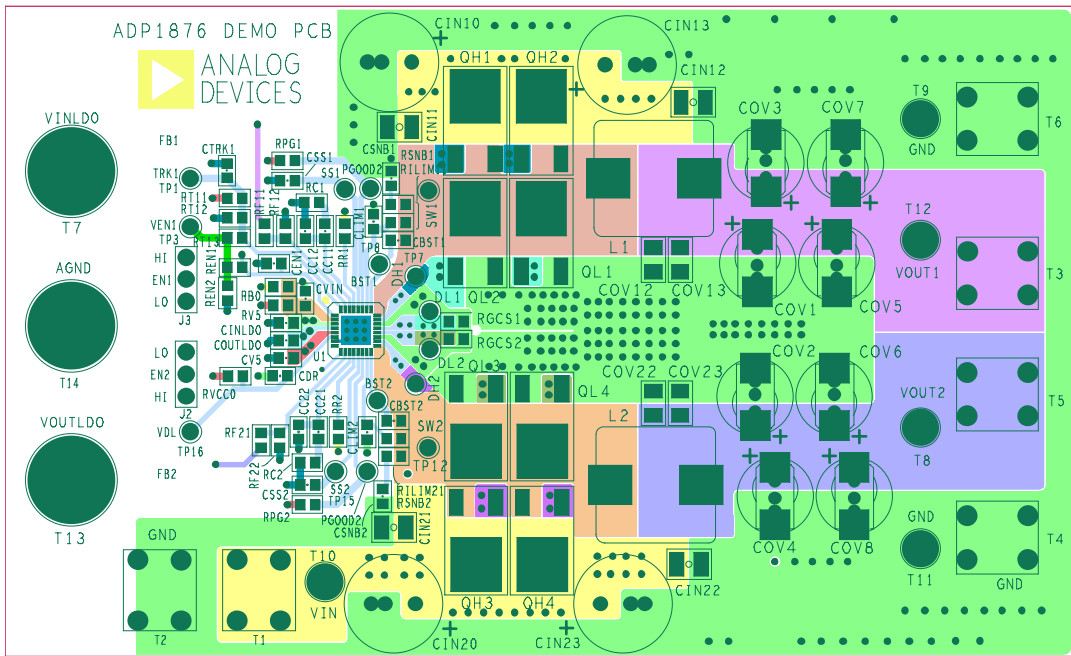

Figure 13. Top Layer

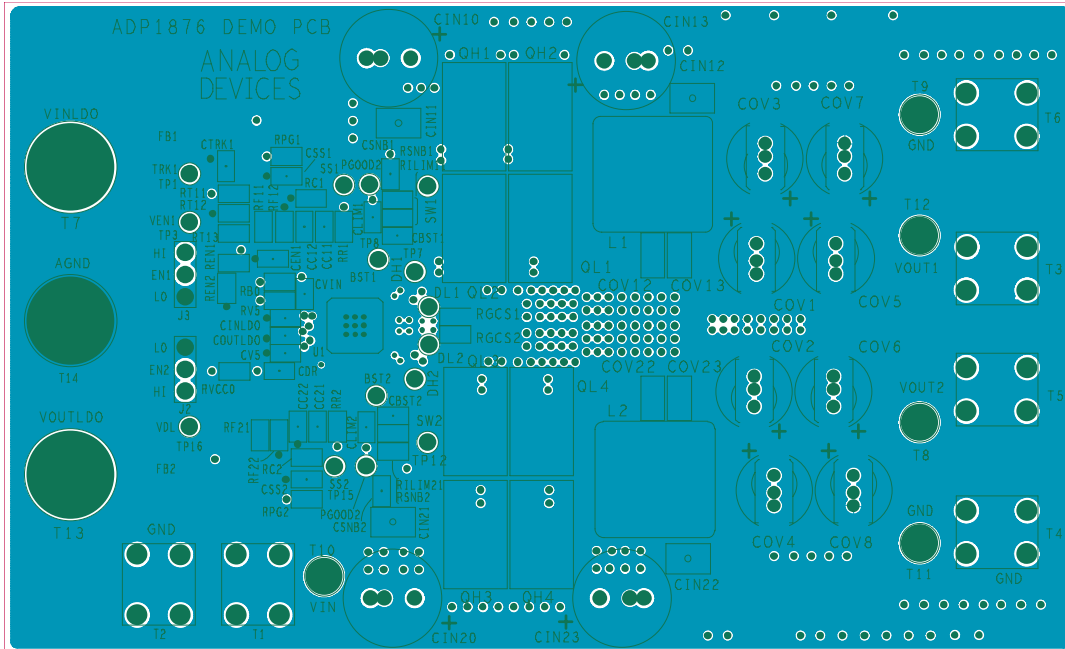

Figure 14. Second Layer (AGND Plane)

10272-014

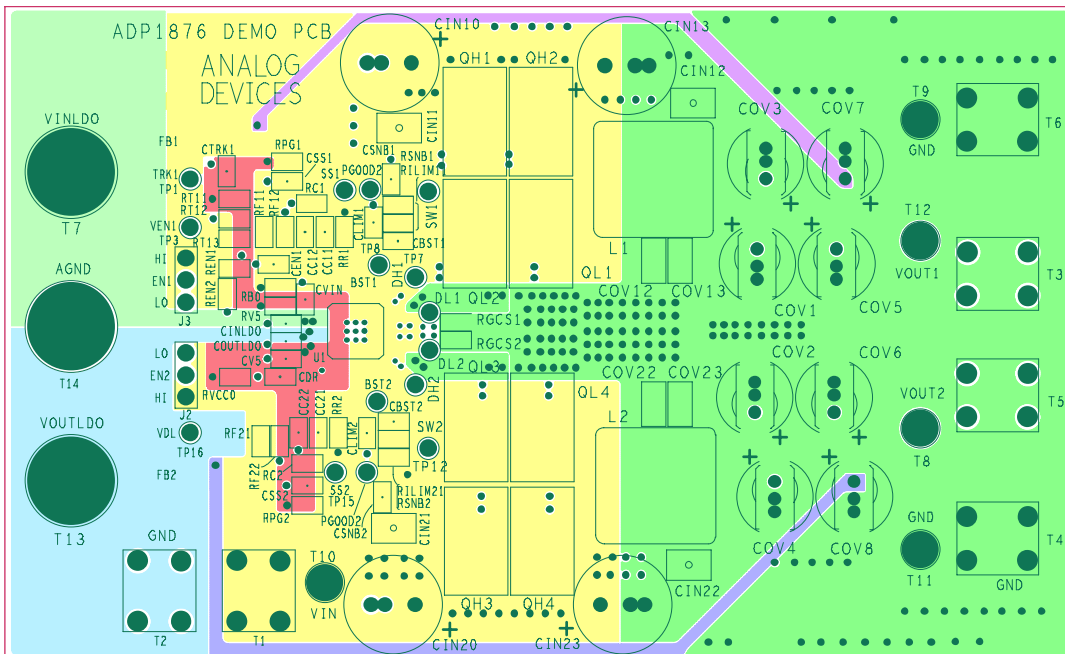

Figure 15. Third Layer (PGND Layer)

10272-015

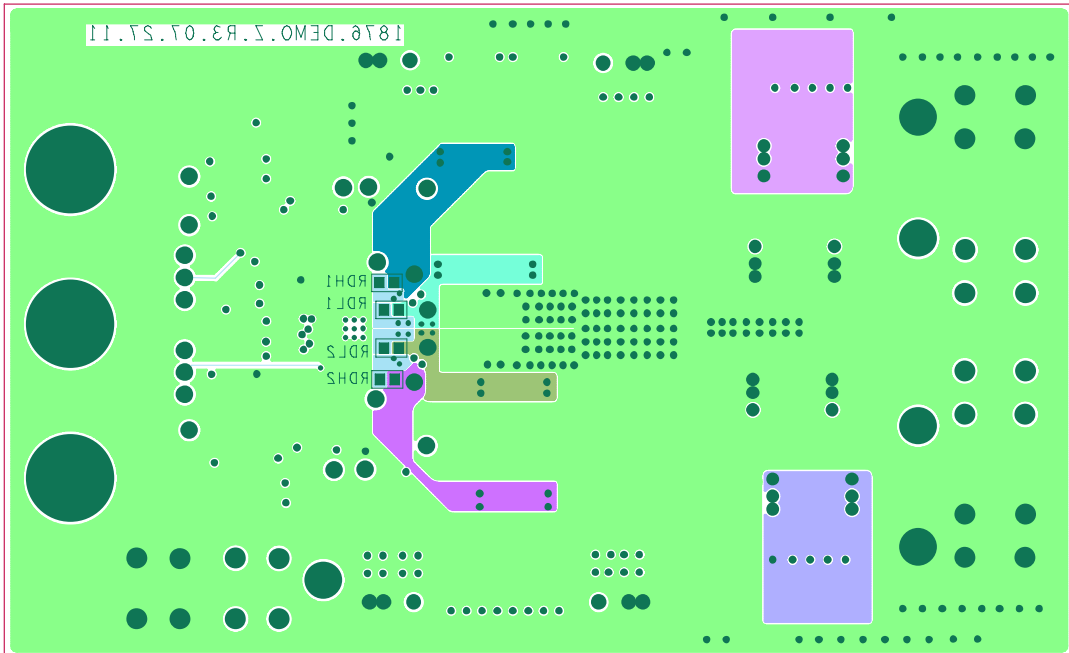

Figure 16. Bottom Layer (PGND Layer)

ORDERING INFORMATION

BILL OF MATERIALS

Table 3.

Qty	Reference Designator	Description	Manufacturer	Part No.
1	U1	ADP1876, 32-lead LFCSP, 5 mm × 5 mm	Analog Devices	ADP1876
4	QH1, QH3, QL2, QL3	N MOSFET, 30 V, 6 mΩ	Infineon	IPD050N03L
2	L1, L2	Inductor, 1.8 μH, 3.5 mΩ, I _N = 16 A, I _{SAT} = 18 A	Würth Elektronik	744325180
4	COV1, COV2, COV5, COV6	POSCAP, 330 μF, 6.3 V, 18 mΩ	SANYO	6TPE330MFL
1	CIN20	OSCON, 150 μF, 20 V	SANYO	20SEP150M
4	CIN11, CIN12, CIN21, CIN22	MLCC, 10 μF, X7R, 25 V	Murata	GRM32DR71E106KA12
1	CVIN	MLCC, 100 nF, X7R, 25 V	Murata	GRM188R71E104KA01D
4	Css1, Css2, Cbst1, Cbst2	MLCC, 100 nF, X7R, 16 V	Murata	GRM188R71E104KA01
2	Cv5, Cdr	MLCC, 1.0 μF, X5R, 6.3 V	Murata	GRM185R60J105KE21
4	COV13, COV23, COV12, COV22	MLCC, 22 μF, X5R, 6.3 V	Murata	GRM31CR60J226ME19L
1	CINLDO	MLCC, 1 μF, 16 V, X7R	Murata	GRM188R71C105KA12
1	COUtlDO	MLCC, 4.7 μF, 6.3 V, X5R	Murata	GRM188R0J475KE19
1	Cc11	MLCC, 120 pF	Vishay	VJ0603Y121KXAA
1	Cc12	MLCC, 10 pF	Vishay	VJ0603A100KXAA
1	Cc21	MLCC, 330 pF	Vishay	VJ0603Y331KXAA
3	Cc22, Clim1, Clim2	MLCC, 22 pF	Vishay	VJ0603A220KXAA
7	Rb0, Rvcco, RDH1, RDH2, RDL1, RDL2, Rt11	Resistor, 0 Ω	Vishay	CRCW06030R00F
2	Rgcs1, Rgcs2	Resistor, 22.6 kΩ	Vishay	CRCW06032262F
2	RR1, RR2	Resistor, 750 kΩ	Vishay	CRCW06031873F
2	Rf12, Rf22	Resistor, 10 kΩ	Vishay	CRCW06031002F
1	Rf11	Resistor, 73.2 kΩ	Vishay	CRCW06037322F
1	Rf21	Resistor, 20 kΩ	Vishay	CRCW06032002F
1	Rc1	Resistor, 124 kΩ	Vishay	CRCW06031243F
1	Rc2	Resistor, 44.2 kΩ	Vishay	CRCW06034422F
2	Rlim11, Rlim21	Resistor, 2.1 kΩ	Vishay	CRCW06032101F
2	J2, J3	3-terminal jumpers, 0.1" spacing	Any	
5	T8, T9, T10, T11, T12	Test points, turret, 110 mil thru hole	Keystone Electronics Corp.	1502-1
6	T1, T2, T3, T4, T5, T6	Terminals	Keystone Electronics Corp.	8191
3	T7, T13, T14	Banana plug	Keystone Electronics Corp.	575-4

NOTES

NOTES

NOTES

NOTES

**ESD Caution**

ESD (electrostatic discharge) sensitive device. Charged devices and circuit boards can discharge without detection. Although this product features patented or proprietary protection circuitry, damage may occur on devices subjected to high energy ESD. Therefore, proper ESD precautions should be taken to avoid performance degradation or loss of functionality.

Legal Terms and Conditions

By using the evaluation board discussed herein (together with any tools, components documentation or support materials, the "Evaluation Board"), you are agreeing to be bound by the terms and conditions set forth below ("Agreement") unless you have purchased the Evaluation Board, in which case the Analog Devices Standard Terms and Conditions of Sale shall govern. Do not use the Evaluation Board until you have read and agreed to the Agreement. Your use of the Evaluation Board shall signify your acceptance of the Agreement. This Agreement is made by and between you ("Customer") and Analog Devices, Inc. ("ADI"), with its principal place of business at One Technology Way, Norwood, MA 02062, USA. Subject to the terms and conditions of the Agreement, ADI hereby grants to Customer a free, limited, personal, temporary, non-exclusive, non-sublicensable, non-transferable license to use the Evaluation Board FOR EVALUATION PURPOSES ONLY. Customer understands and agrees that the Evaluation Board is provided for the sole and exclusive purpose referenced above, and agrees not to use the Evaluation Board for any other purpose. Furthermore, the license granted is expressly made subject to the following additional limitations: Customer shall not (i) rent, lease, display, sell, transfer, assign, sublicense, or distribute the Evaluation Board; and (ii) permit any Third Party to access the Evaluation Board. As used herein, the term "Third Party" includes any entity other than ADI, Customer, their employees, affiliates and in-house consultants. The Evaluation Board is NOT sold to Customer; all rights not expressly granted herein, including ownership of the Evaluation Board, are reserved by ADI. CONFIDENTIALITY. This Agreement and the Evaluation Board shall all be considered the confidential and proprietary information of ADI. Customer may not disclose or transfer any portion of the Evaluation Board to any other party for any reason. Upon discontinuation of use of the Evaluation Board or termination of this Agreement, Customer agrees to promptly return the Evaluation Board to ADI. ADDITIONAL RESTRICTIONS. Customer may not disassemble, decompile or reverse engineer chips on the Evaluation Board. Customer shall inform ADI of any occurred damages or any modifications or alterations it makes to the Evaluation Board, including but not limited to soldering or any other activity that affects the material content of the Evaluation Board. Modifications to the Evaluation Board must comply with applicable law, including but not limited to the RoHS Directive. TERMINATION. ADI may terminate this Agreement at any time upon giving written notice to Customer. Customer agrees to return to ADI the Evaluation Board at that time. LIMITATION OF LIABILITY. THE EVALUATION BOARD PROVIDED HEREUNDER IS PROVIDED "AS IS" AND ADI MAKES NO WARRANTIES OR REPRESENTATIONS OF ANY KIND WITH RESPECT TO IT. ADI SPECIFICALLY DISCLAIMS ANY REPRESENTATIONS, ENDORSEMENTS, GUARANTEES, OR WARRANTIES, EXPRESS OR IMPLIED, RELATED TO THE EVALUATION BOARD INCLUDING, BUT NOT LIMITED TO, THE IMPLIED WARRANTY OF MERCHANTABILITY, TITLE, FITNESS FOR A PARTICULAR PURPOSE OR NON-INFRINGEMENT OF INTELLECTUAL PROPERTY RIGHTS. IN NO EVENT WILL ADI AND ITS LICENSORS BE LIABLE FOR ANY INCIDENTAL, SPECIAL, INDIRECT, OR CONSEQUENTIAL DAMAGES RESULTING FROM CUSTOMER'S POSSESSION OR USE OF THE EVALUATION BOARD, INCLUDING BUT NOT LIMITED TO LOST PROFITS, DELAY COSTS, LABOR COSTS OR LOSS OF GOODWILL. ADI'S TOTAL LIABILITY FROM ANY AND ALL CAUSES SHALL BE LIMITED TO THE AMOUNT OF ONE HUNDRED US DOLLARS (\$100.00). EXPORT. Customer agrees that it will not directly or indirectly export the Evaluation Board to another country, and that it will comply with all applicable United States federal laws and regulations relating to exports. GOVERNING LAW. This Agreement shall be governed by and construed in accordance with the substantive laws of the Commonwealth of Massachusetts (excluding conflict of law rules). Any legal action regarding this Agreement will be heard in the state or federal courts having jurisdiction in Suffolk County, Massachusetts, and Customer hereby submits to the personal jurisdiction and venue of such courts. The United Nations Convention on Contracts for the International Sale of Goods shall not apply to this Agreement and is expressly disclaimed.