

DRV10974 Evaluation Module

This document is provided with the DRV10974 customer evaluation module (EVM) as a supplement to [DRV10974 Three-Phase, Sensorless BLDC Motor Driver](#). The user's guide details the hardware implementation of the EVM and gives a step-by-step introduction to device operation.

Contents

1	DRV10974 EVM Kit Contents	3
2	Introduction	3
	2.1 Features.....	3
3	Quick Start Guide.....	5
4	DRV10974 Onboard Connections	7
	4.1 Connector (P1) for Power Input.....	7
	4.2 Interface Connector (P2) for Phase Windings of Motor.....	8
5	DRV10974 Package.....	9
6	User Interface	10
	6.1 Jumpers	10
	6.2 Switch	11
	6.3 Test Points	11
7	CS, RMP, and ADV Resistor Selection	12
	7.1 CS Resistor Table.....	12
	7.2 RMP Resistor Table	13
	7.3 ADV Resistor Table	13
8	Schematic	14
9	Bill of Materials (BOM).....	15
10	EVM Documentation	16

List of Figures

1	DRV10974 EVM	4
2	DRV10974 EVM With Various Connections and User Interface	5
3	Jumper Configurations for Controlling Speed With Analog Voltage	6
4	Jumper Configurations for Controlling Speed With PWM Signal.....	6
5	Power Input Terminal Block (P1)	7
6	Motor Phase Windings Input Terminal Block (P2)	8
7	DRV10974PWP Pinout	9
8	CS Receptacle (J10).....	10
9	ADV Receptacle (J8)	10
10	RMP Receptacle (J9)	10
11	Speed Command Input Select Header (J3)	11
12	Potentiometer Power Header (J2)	11
13	DRV10974 EVM Schematic.....	14

List of Tables

1	Connector P1: 2-Terminal Connector to Connect Power	7
2	Connector P2: 3-Terminal Connector to Connect 3-Phase BLDC Motor	8
3	DRV10974PWP Pinout	9

4	Test Point Descriptions	11
5	CS Resistor Table.....	12
6	RMP Resistor Table	13
7	ADV Resistor Table	13
8	Bill of Materials for DRV10974EVM.....	15

Trademarks

All trademarks are the property of their respective owners.

1 DRV10974 EVM Kit Contents

The DRV10974 evaluation kit contains the DRV10974 EVM.

2 Introduction

The DRV10974 EVM is an evaluation platform for the DRV10974 three-phase, sensorless, BLDC motor driver.

2.1 Features

The EVM has the following features:

- 180° Sinusoidal Commutation
- Soft Start With Resistor-Configurable Acceleration Profile
- Protection Features:
 - Overcurrent
 - Undervoltage
 - Overtemperature
 - Motor-Lock Detect and Restart

This document describes functions and locations of test points, jumpers, and connectors present on the DRV10974EVM board. For detailed information about the DRV10974 device, see [DRV10974 Three-Phase, Sensorless BLDC Motor Driver](#).

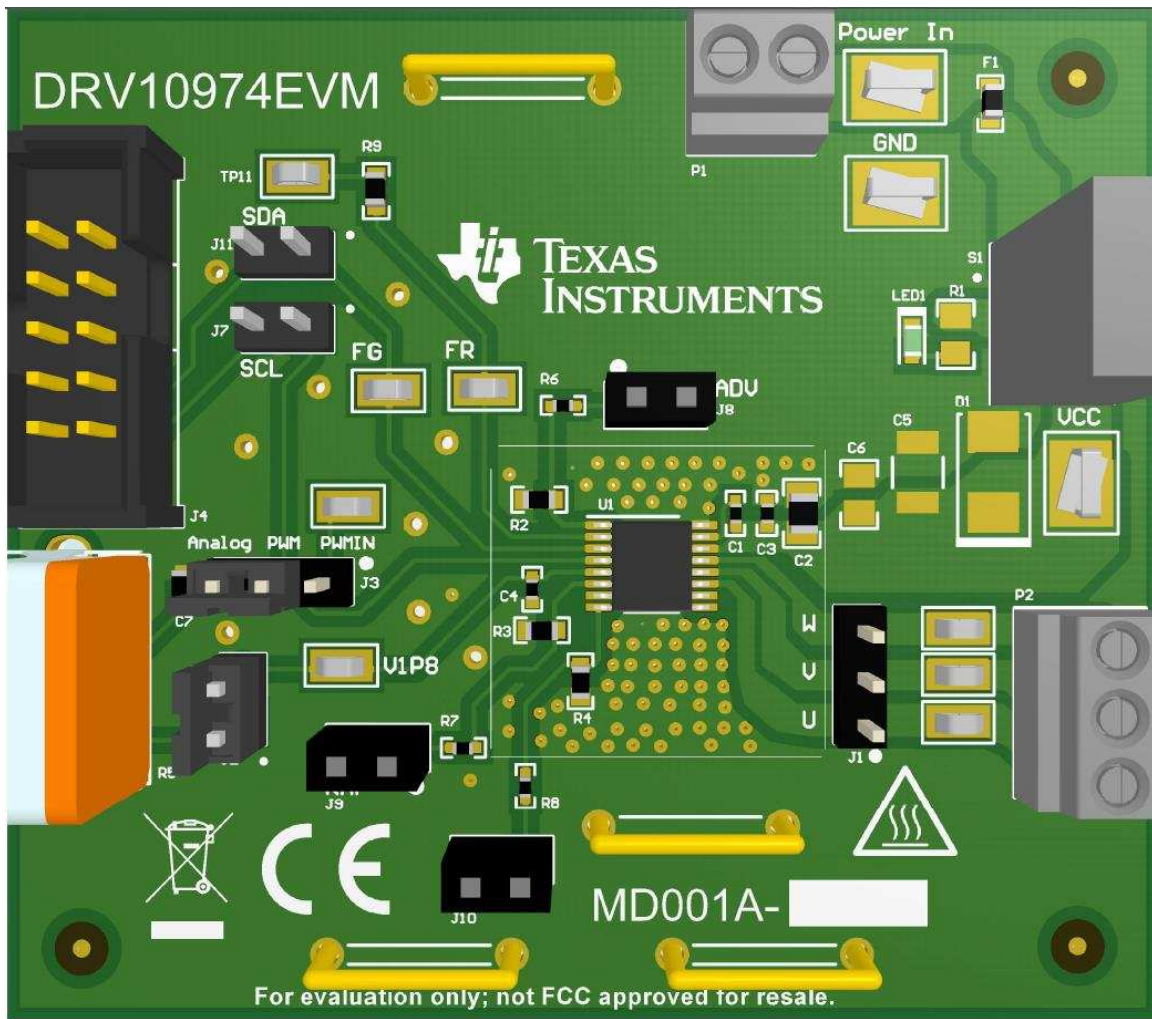



Figure 1. DRV10974 EVM

WARNING



Hot surface. Contact may cause burns. Do not touch!

3 Quick Start Guide

The DRV10974 EVM requires a V_{CC} power supply source, which has a recommended operating range from 4.4 V to 18 V. Use the following sequence to power up the EVM:

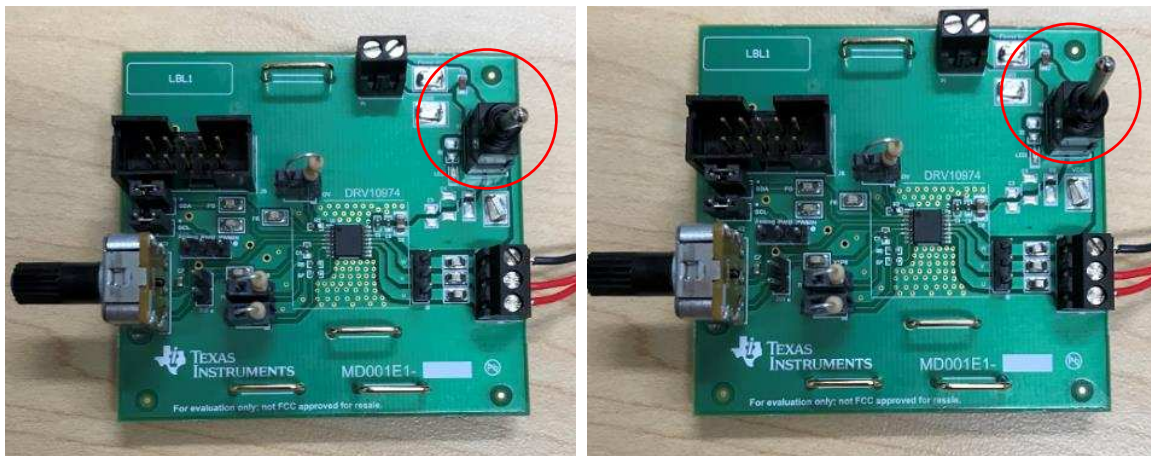

Power On

Power Off

Figure 2. DRV10974 EVM With Various Connections and User Interface

1. Connect the power supply ground to pin 2 (GND) and a voltage between 4.4 V and 18 V to pin 1 of connector P1 (Power In). Set the current limit on the power supply to 1.5 A and make sure switch S1 is in the Off (Up) position as shown in [Figure 2](#).
2. Use the default ADV, RMP, and CS resistor values (or set them up in [Section 7](#)).
3. Determine whether to use an analog voltage or PWM to control the speed of the motor.
 - For using an analog voltage to control the speed: match the jumpers as shown in [Figure 3](#) and use the potentiometer (R5) to control the speed.
 - For using a PWM signal to control the speed: match the jumpers as shown in [Figure 4](#) and connect the PWM signal to the PWMIN test point.
4. Power up the board and turn the switch S1 to the On (Down) position.

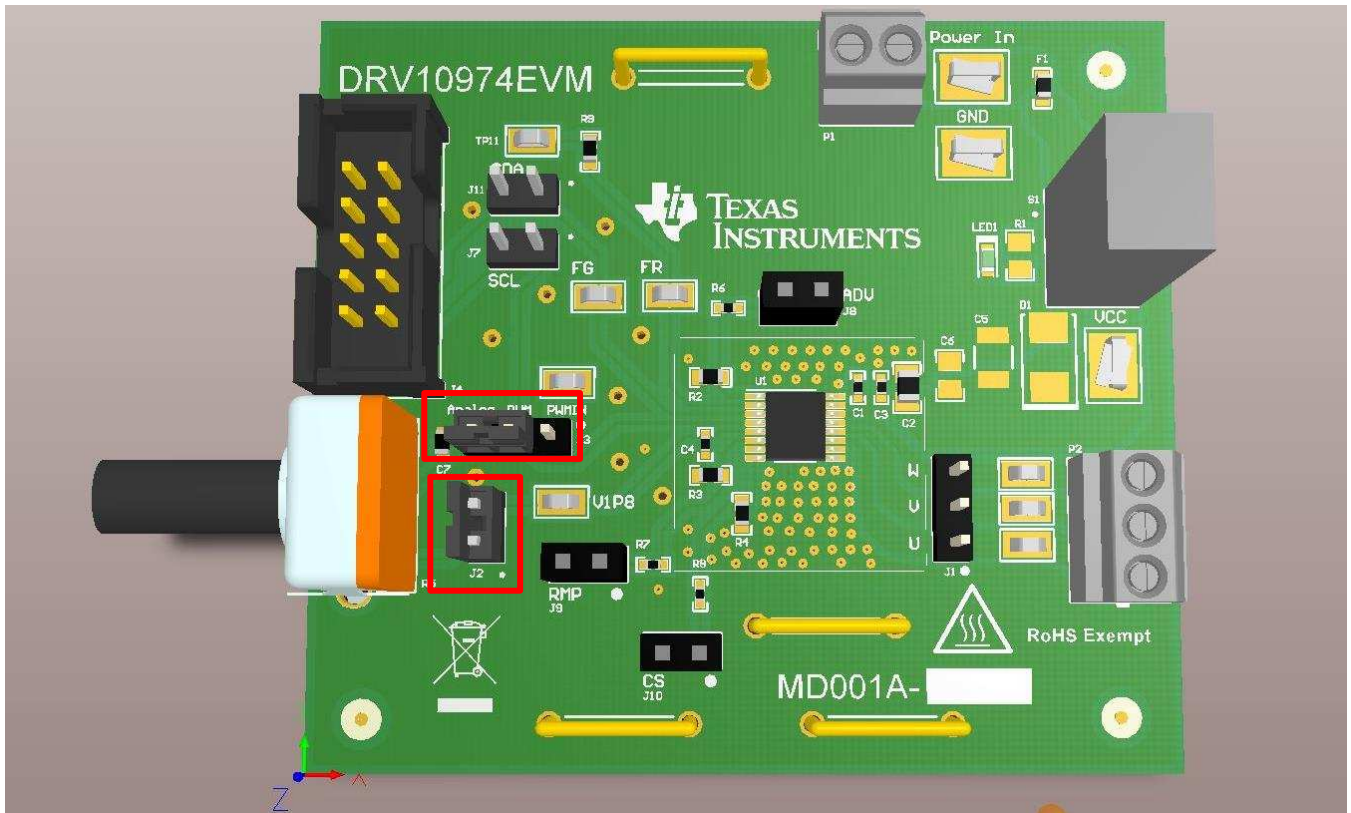

Figure 3. Jumper Configurations for Controlling Speed With Analog Voltage

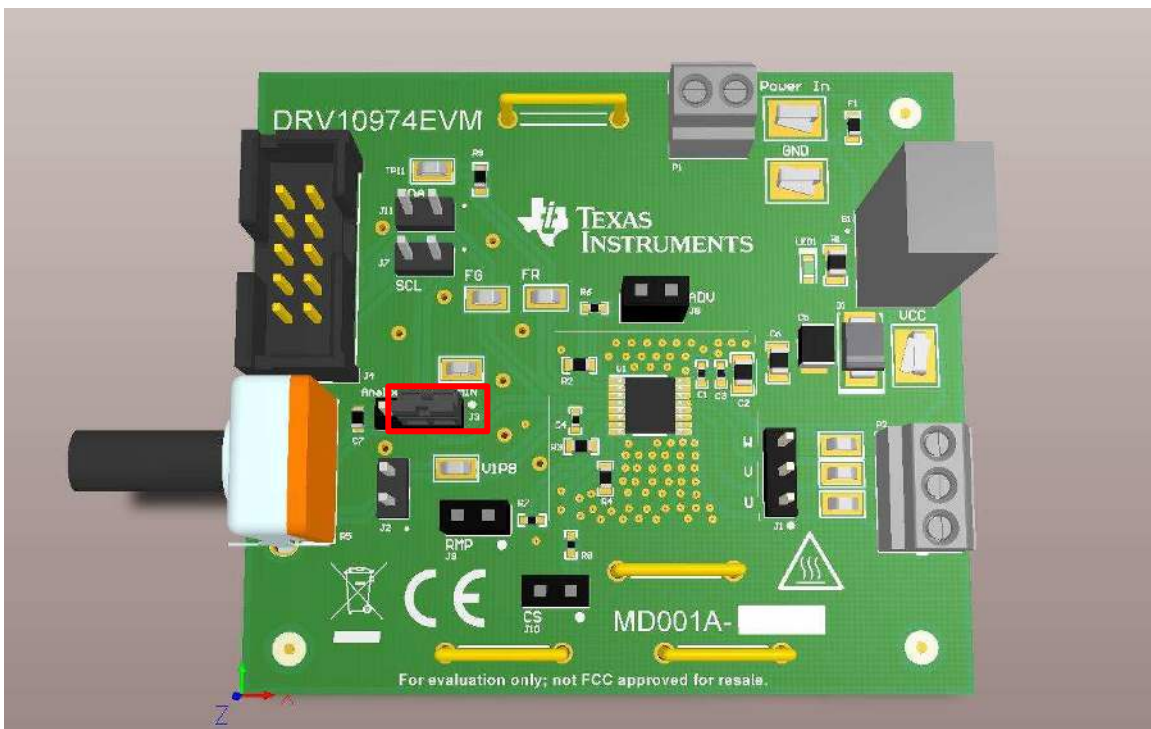

Figure 4. Jumper Configurations for Controlling Speed With PWM Signal

4 DRV10974 Onboard Connections

4.1 Connector (P1) for Power Input

The DRV10974 device requires an external power supply (4.4 V to 18 V) to operate. Connector P1 provides the required interface for the external power supply. The pin assignment of terminal P1 is as follows:

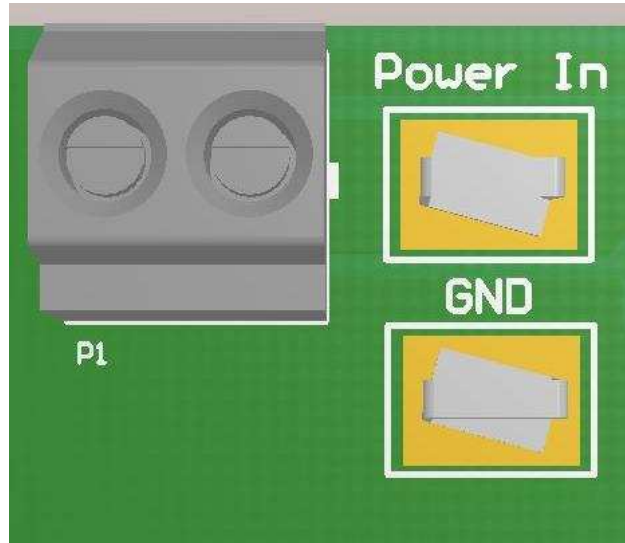

Figure 5. Power Input Terminal Block (P1)

Table 1. Connector P1: 2-Terminal Connector to Connect Power

TERMINAL	DESCRIPTION
1 ⁽¹⁾	V _{CC}
2	GND

⁽¹⁾ Note that terminal 1 is denoted by the small, silkscreened rectangle on the board at the right side of the terminal block.

4.2 Interface Connector (P2) for Phase Windings of Motor

Connector P2 is used to interface the U, V, and W phases. The pin assignments are as follows:

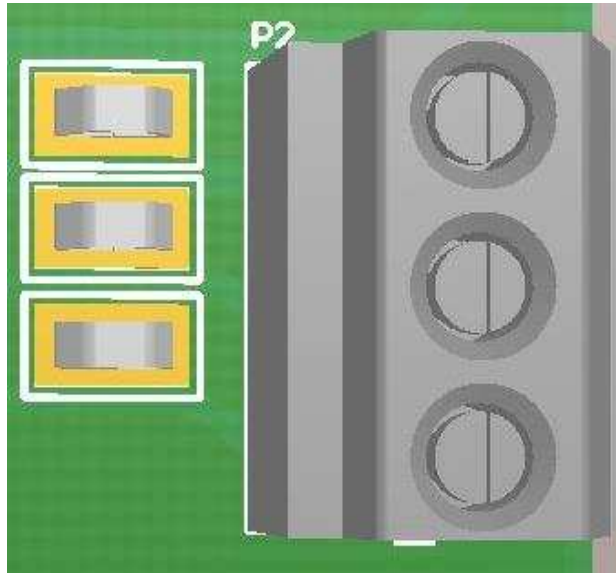

Figure 6. Motor Phase Windings Input Terminal Block (P2)

Table 2. Connector P2: 3-Terminal Connector to Connect 3-Phase BLDC Motor

TERMINAL	DESCRIPTION
1 ⁽¹⁾	Phase-U
2	Phase-V
3	Phase-W

⁽¹⁾ Note that terminal 1 is denoted by the small, silkscreened rectangle on the board at the right side of the terminal block.

5 DRV10974 Package

The DRV10974PWP pinout is listed in [Figure 7](#).

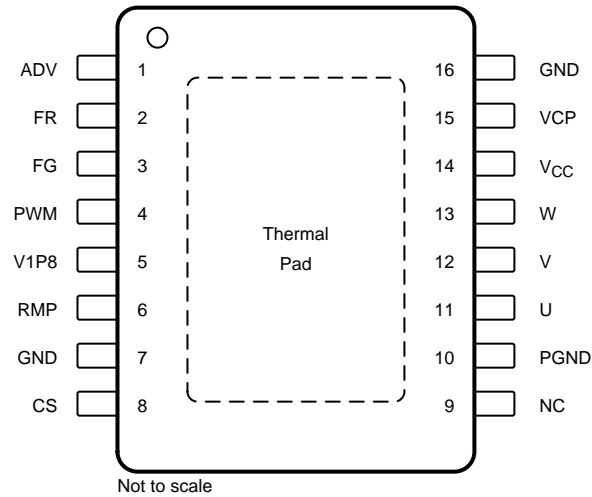

Figure 7. DRV10974PWP Pinout

Table 3. DRV10974PWP Pinout

PIN NUMBER	PIN NAME
1	ADV
2	FR
3	FG
4	PWM
5	V1P8
6	RMP
7	GND
8	CS
9	NC
10	PGND
11	U
12	V
13	W
14	V _{CC}
15	VCP
16	GND

The DRV10974PWP device is packaged in a 16-pin, TSSOP package. For detailed information about the DRV10974PWP device, see [DRV10974 Three-Phase, Sensorless BLDC Motor Driver](#).

NOTE: The DRV10974EVM is only available using the DRV10974PWP package and is sufficient to evaluate the functionality of both the DRV10974PWP and DRV10974RUM package variants.

6 User Interface

6.1 Jumpers

Descriptions for the jumpers are provided in the following list:

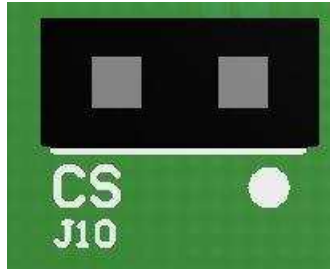

Figure 8. CS Receptacle (J10)

- **CS (J10)** is the *current limit* setting. CS connects a resistor to GND for current-limit setting. This receptacle is meant for easy implementation of axial-lead through-hole resistors. Otherwise, R4 can be used for substitution of surface-mount resistors.

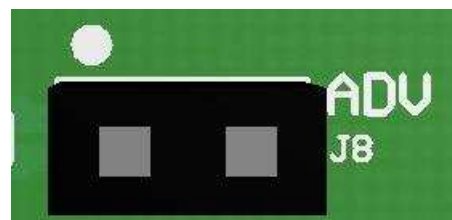

Figure 9. ADV Receptacle (J8)

- **ADV (J8)** is the *lead angle* setting. ADV connects a resistor to GND for lead angle setting. This receptacle is meant for easy implementation of axial-lead through-hole resistors. Otherwise, R2 can be used for substitution of surface-mount resistors.

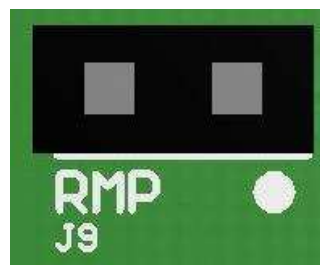

Figure 10. RMP Receptacle (J9)

- **RMP (J9)** is the *acceleration ramp-rate control* setting. RMP connects a resistor to GND for setting the acceleration ramp-rate control. This receptacle is meant for easy implementation of axial-lead through-hole resistors. Otherwise, R3 can be used for substitution of surface-mount resistors.



Figure 11. Speed Command Input Select Header (J3)

- **Select (J3)** is used to configure motor speed-control resources for the PWM pin. Set the PWM jumper to *PWMIN* for sending a PWM signal to the PWM pin to control motor speed. See [Figure 4](#) for more details. Set the PWM jumper to *Analog* with J2 connected for using potentiometer (R5) to control motor speed. See [Figure 3](#) for more details.
- **J7 and J11 Connections** are placeholders for an I²C interface, so they can be ignored.

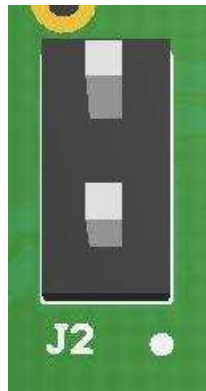

Figure 12. Potentiometer Power Header (J2)

- **Potentiometer Power (J2)** provides voltage from the V1P8 pin of the DRV10974 device to power the potentiometer. This header must be jumpered to use the potentiometer.

6.2 Switch

The **S1** switch allows the applied power supply voltage to reach the rest of the board. A fuse is used to protect the device from overcurrent. Turn the switch to the On position to power the EVM.

6.3 Test Points

Test points are provided and labeled according to the inputs and outputs of the DRV10974 motor driver (see [Table 4](#)).

Table 4. Test Point Descriptions

TEST POINT	NAME	DESCRIPTION
TP1	Power In	Used to power board in conjunction with the switch (S1)
TP2	VCC	Used to power board and bypass the switch (S1)
TP3	U Phase	Input for 1 of the 3 motor phase windings of the BLDC motor
TP4	V Phase	Input for 1 of the 3 motor phase windings of the BLDC motor
TP5	W Phase	Input for 1 of the 3 motor phase windings of the BLDC motor

Table 4. Test Point Descriptions (continued)

TEST POINT	NAME	DESCRIPTION
TP6	GND	GND plane of board
TP7	V1P8	Output of V1P8 pin. Can probe during debug
TP8	FR	Connection to FR pin. Can be pulled up to change direction of motor
TP9	PWMIN	Input of PWM signal used for input speed command
TP10	FG	Output of FG pin. Used to monitor speed of motor
TP11	—	Placeholder for FR pullup, can be ignored

CAUTION

Do not apply power to the board before you have read [Section 3!](#)

7 CS, RMP, and ADV Resistor Selection

Note that the three pins, CS, RMP, and ADV, are used to configure settings for the DRV10974 device. The receptacles (J10, J9, and J8) on the CS, RMP, and ADV pins are used for installing axial-lead, through-hole resistors to quickly configure settings on the DRV10974EVM. Note that R6, R7, and R8 are 0402, 0- Ω surface-mount resistors in series with the receptacles. They give the user flexibility to achieve the desired resistor values if necessary.

In addition, the 0603 surface mount resistors (R4, R3, and R2) can also be replaced or removed to configure the settings. Because these resistors are populated by default, it is highly recommended to remove these resistors or to calculate the parallel resistance if the receptacles are used. This is shown in [Figure 13](#). See the [DRV10974 Tuning Guide](#) for more information.

Furthermore, ensure all resistors have 1% tolerance for CS, RMP, and ADV pins.

7.1 CS Resistor Table

The CS resistor controls the current limit setting on the DRV10974 device. More information can be found in [DRV10974 12-V, Three-Phase, Sensorless BLDC Motor Driver](#). The default resistor on the DRV10974EVM is 115 k Ω , which sets the current limit to 1.4A.

Table 5. CS Resistor Table

$R_{(CS)}$ [k Ω]	$I_{(LIMIT)}$ [mA]
7.32	200
16.2	400
25.5	600
38.3	800
54.9	1000
80.6	1200
115	1400
182	1600 (1500 during align and start-up)

7.2 RMP Resistor Table

The RMP resistor controls the open-loop start-up acceleration, closed-loop acceleration, and closed-loop deceleration. More information can be found in [DRV10974 12-V, Three-Phase, Sensorless BLDC Motor Driver](#). The default resistor on the DRV10974EVM is 7.32 k Ω , which sets the second-order acceleration coefficient, the first-order acceleration coefficient, the closed-loop acceleration, and the closed-loop deceleration to 0.22 Hz/s², 4.6 Hz/s, 2.7 s, and 44 s, respectively. This is the slowest ramp rate.

Table 6. RMP Resistor Table

RMP SELECTION	R _{RMP} [k Ω]	ACCEL2 [Hz/s ²]	ACCEL1 [Hz/s]	CLOSED-LOOP-ACCELERATION TRANSITION TIME [s]	CLOSED-LOOP-DECELERATION TRANSITION TIME [s]
0	7.32	0.22	4.6	2.7	44
1	10.7	1.65	9.2	2.7	22
2	14.3	1.65	15	1	22
3	17.8	3.3	25	1	11
4	22.1	7	25	0.2	44
5	28	7	35	0.2	22
6	34	14	50	0.2	22
7	41.2	27	75	0.2	11
8	49.9	27	75	5.4	11
9	59	14	50	8	22
10	71.5	7	35	11	22
11	86.6	7	25	22	44
12	105	3.3	25	5.4	11
13	124	1.65	15	8	22
14	150	1.65	9.2	11	22
15	182	0.22	4.6	22	44

7.3 ADV Resistor Table

The ADV resistor controls the lead time in order to drive the motor with the best efficiency. More information can be found in [DRV10974 12-V, Three-Phase, Sensorless BLDC Motor Driver](#). The default resistor on the DRV10974EVM is 59 k Ω , which sets the lead time to 400 μ s.

Table 7. ADV Resistor Table

R _{ADV} [k Ω]	LEAD TIME [μ s]
10.7	10
14.3	25
17.8	50
22.1	100
28	150
34	200
41.2	250
49.9	300
59	400
71.5	500
86.6	600
105	700
124	800
150	900
182	1000

8 Schematic

Figure 13 illustrates the EVM schematic.

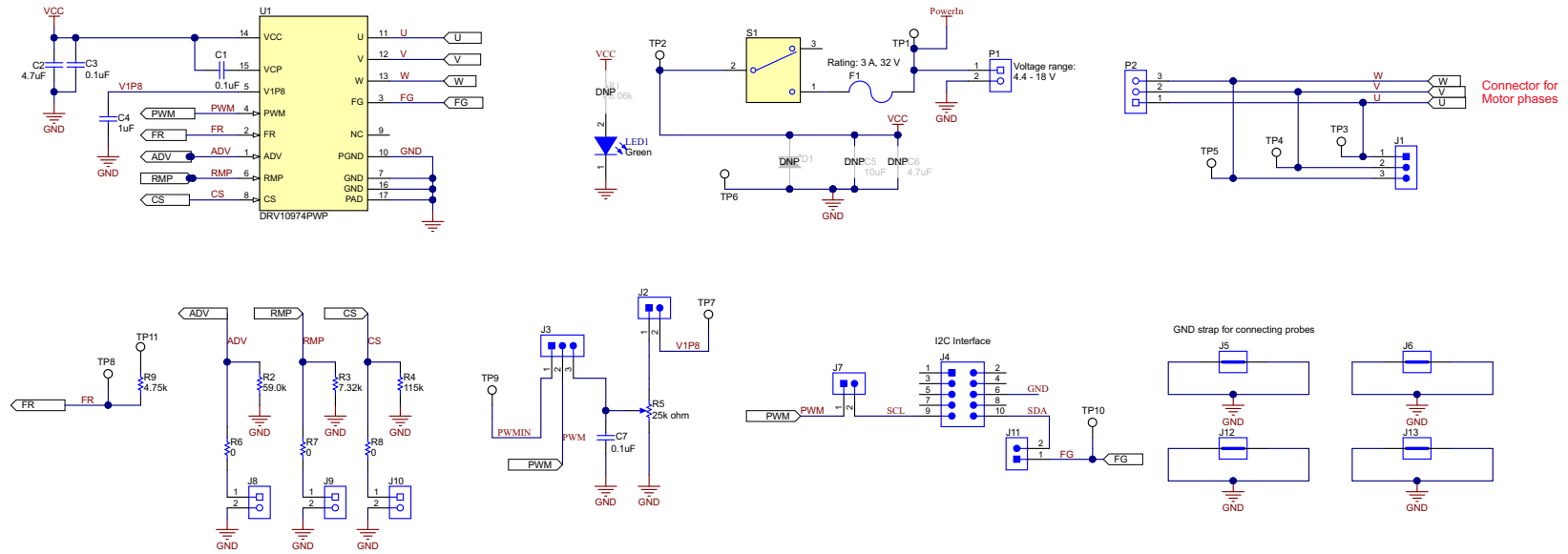

Figure 13. DRV10974 EVM Schematic

9 Bill of Materials (BOM)

Table 8. Bill of Materials for DRV10974EVM

DESIGNATOR	QUANTITY	VALUE	DESCRIPTION	PACKAGE REFERENCE	PART NUMBER	MANUFACTURER
PCB1	1	—	Printed circuit board		MD001	Any
C1	1	0.1 μ F	Capacitor, ceramic, 0.1 μ F, 50 V, 10%, X7R, 0402	0402	C1005X7R1H104K050BE	TDK
C2	1	4.7 μ F	Capacitor, ceramic, 4.7 μ F, 50 V, \pm 10%, X5R, 0805	0805	C2012X5R1H475K125AB	TDK
C3	1	0.1 μ F	Capacitor, ceramic, 0.1 μ F, 25 V, \pm 20%, X7R, 0402	0402	C1005X7R1E104M050BB	TDK
C4	1	1 μ F	Capacitor, ceramic, 1 μ F, 10 V, \pm 10%, X7S, 0402	0402	C1005X7S1A105K050BC	TDK
C7	1	0.1 μ F	Capacitor, ceramic, 0.1 μ F, 50 V, \pm 10%, X7R, 0603	0603	06035C104KAT2A	AVX
F1	1	—	Fuse, 3 A, 32 VDC, SMD	0603	F0603E3R00FSTR	AVX
H1, H2, H3, H4	4	—	Bumpon, hemisphere, 0.44 x 0.20, clear	Transparent bumpon	SJ-5303 (CLEAR)	3M
J1, J3	2	—	Header, 100 mil, 3x1, tin, TH	Header, 3 pin, 100 mil, tin	PEC03SAAN	Sullins Connector Solutions
J2, J7, J11	3	—	header, 100 mil, 2x1, tin, TH	Header, 2x1	90120-0122	Molex
J4	1	—	Header (shrouded), 100 mil, 5x2, gold, TH	5x2 shrouded header	5103308-1	TE Connectivity
J5, J6, J12, J13	4	—	1-mm uninsulated shorting plug, 10.16-mm spacing, TH	Shorting plug, 10.16 mm spacing, TH	D3082-05	Harwin
J8, J9, J10	3	—	Receptacle, 100 mil, 2x1, tin, TH	Receptacle, 2x1, 100 mil, tin	PPTC021LFBN-RC	Sullins Connector Solutions
LED1	1	Green	LED, green, SMD	LED_0603	150060VS75000	Wurth Elektronik
P1	1	—	Terminal block, 3.5 mm, 2x1, tin, TH	Terminal block, 3.5 mm, 2x1, TH	39357-0002	Molex
P2	1	—	Terminal block, 3.5 mm, 3x1, tin, TH	Terminal block, 3.5 mm, 3x1, TH	39357-0003	Molex
R2	1	59.0 k Ω	Resistor, 59.0 k Ω , 1%, 0.1 W, 0603	0603	RC0603FR-0759KL	Yageo America
R3	1	7.32 k Ω	Resistor, 7.32 k Ω , 1%, 0.1 W, 0603	0603	RC0603FR-077K32L	Yageo America
R4	1	115 k Ω	Resistor, 115 k Ω , 1%, 0.1 W, 0603	0603	RC0603FR-07115KL	Yageo America
R5	1	25 k Ω	Trimmer, 25 k Ω , 0.15 W, TH	6.3 mmx12.5 mm	296XD253B1N	CTS Electrocomponents
R6, R7, R8	3	0	Resistor, 0, 5%, 0.063 W, 0402	0402	MCR01MZPJ000	Rohm
R9	1	4.75 k Ω	Resistor, 4.75 k Ω , 1%, 0.1 W, 0603	0603	RC0603FR-074K75L	Yageo America
S1	1	—	Switch, toggle, SPDT 0.4 VA, 28 V	6.8x23.1x8.8 mm	B12AP	NKK Switches
SH-J1, SH-J2	2	—	Shunt, 100 mil, gold plated, black	Shunt 2 pos. 100 mil	881545-2	TE Connectivity

Table 8. Bill of Materials for DRV10974EVM (continued)

TP1, TP2, TP6	3	—	Test point, compact, SMT	Testpoint_Keystone_Compact	5016	Keystone
TP3, TP4, TP5, TP7, TP8, TP9, TP10, TP11	8	—	Test point, miniature, SMT	Testpoint_Keystone_Miniature	5015	Keystone
U1	1	—	12-V, Three-phase, sensorless BLDC motor driver, PWP0016J (TSSOP-16)	PWP0016J	DRV10974PWP	Texas Instruments
C5	0	10 μ F	Capacitor, ceramic, 10 μ F, 50 V, \pm 20%, X7R, 1210	1210	C3225X7R1H106M250AC	TDK
C6	0	4.7 μ F	Capacitor, ceramic, 4.7 μ F, 50 V, \pm 10%, X5R, 0805	0805	C2012X5R1H475K125AB	TDK
D1	0	20 V	Diode, Schottky, 20 V, 2 A, SMB	SMB	SL22-E3/52T	Vishay-Semiconductor
FID1, FID2, FID3	0	—	Fiducial mark. There is nothing to buy or mount.	N/A	N/A	N/A
R1	0	8.06 k Ω	Resistor, 8.06 k Ω , 1%, 0.125 W, AEC-Q200 Grade 0, 0805	0805	CRCW08058K06FKEA	Vishay-Dale

10 EVM Documentation

The EVM schematics, layout, and bill of materials (BOM) are in the hardware files provided on [DRV10974 12-V, Three-Phase, Sensorless BLDC Motor Driver Evaluation Module](#).

Revision History

NOTE: Page numbers for previous revisions may differ from page numbers in the current version.

Changes from B Revision (March 2018) to C Revision	Page
• Changed part number DRV10974 to DRV10974PWP in several places in the document	9
• Added a note about package availability and applicability	9

Changes from A Revision (January 2018) to B Revision	Page
• Changed <i>Features</i> section to reflect DRV10974 data sheet.....	3
• Added more detail to <i>Quick Start Guide</i> section and added jumper configuration figures.....	5
• Changed <i>DRV10974 Onboard Connections</i> section to reflect Revision A layout of the DRV10974EVM.	7
• Added <i>CS, RMP, and ADV Resistor Selection</i> section to help user choose configurable settings without directly consulting datasheet	12
• Changed schematic to reflect Revision A of DRV10974EVM	14
• Added the <i>Bill of Materials</i> for Revision A of the DRV10974EVM.....	16

Changes from Original (December 2017) to A Revision	Page
• Added the <i>Schematic</i> section.	14

STANDARD TERMS FOR EVALUATION MODULES

1. *Delivery:* TI delivers TI evaluation boards, kits, or modules, including any accompanying demonstration software, components, and/or documentation which may be provided together or separately (collectively, an "EVM" or "EVMs") to the User ("User") in accordance with the terms set forth herein. User's acceptance of the EVM is expressly subject to the following terms.
 - 1.1 EVMs are intended solely for product or software developers for use in a research and development setting to facilitate feasibility evaluation, experimentation, or scientific analysis of TI semiconductor products. EVMs have no direct function and are not finished products. EVMs shall not be directly or indirectly assembled as a part or subassembly in any finished product. For clarification, any software or software tools provided with the EVM ("Software") shall not be subject to the terms and conditions set forth herein but rather shall be subject to the applicable terms that accompany such Software
 - 1.2 EVMs are not intended for consumer or household use. EVMs may not be sold, sublicensed, leased, rented, loaned, assigned, or otherwise distributed for commercial purposes by Users, in whole or in part, or used in any finished product or production system.
2. *Limited Warranty and Related Remedies/Disclaimers:*
 - 2.1 These terms do not apply to Software. The warranty, if any, for Software is covered in the applicable Software License Agreement.
 - 2.2 TI warrants that the TI EVM will conform to TI's published specifications for ninety (90) days after the date TI delivers such EVM to User. Notwithstanding the foregoing, TI shall not be liable for a nonconforming EVM if (a) the nonconformity was caused by neglect, misuse or mistreatment by an entity other than TI, including improper installation or testing, or for any EVMs that have been altered or modified in any way by an entity other than TI, (b) the nonconformity resulted from User's design, specifications or instructions for such EVMs or improper system design, or (c) User has not paid on time. Testing and other quality control techniques are used to the extent TI deems necessary. TI does not test all parameters of each EVM. User's claims against TI under this Section 2 are void if User fails to notify TI of any apparent defects in the EVMs within ten (10) business days after delivery, or of any hidden defects with ten (10) business days after the defect has been detected.
 - 2.3 TI's sole liability shall be at its option to repair or replace EVMs that fail to conform to the warranty set forth above, or credit User's account for such EVM. TI's liability under this warranty shall be limited to EVMs that are returned during the warranty period to the address designated by TI and that are determined by TI not to conform to such warranty. If TI elects to repair or replace such EVM, TI shall have a reasonable time to repair such EVM or provide replacements. Repaired EVMs shall be warranted for the remainder of the original warranty period. Replaced EVMs shall be warranted for a new full ninety (90) day warranty period.
3. *Regulatory Notices:*
 - 3.1 *United States*
 - 3.1.1 *Notice applicable to EVMs not FCC-Approved:*

FCC NOTICE: This kit is designed to allow product developers to evaluate electronic components, circuitry, or software associated with the kit to determine whether to incorporate such items in a finished product and software developers to write software applications for use with the end product. This kit is not a finished product and when assembled may not be resold or otherwise marketed unless all required FCC equipment authorizations are first obtained. Operation is subject to the condition that this product not cause harmful interference to licensed radio stations and that this product accept harmful interference. Unless the assembled kit is designed to operate under part 15, part 18 or part 95 of this chapter, the operator of the kit must operate under the authority of an FCC license holder or must secure an experimental authorization under part 5 of this chapter.
 - 3.1.2 *For EVMs annotated as FCC – FEDERAL COMMUNICATIONS COMMISSION Part 15 Compliant:*

CAUTION

This device complies with part 15 of the FCC Rules. Operation is subject to the following two conditions: (1) This device may not cause harmful interference, and (2) this device must accept any interference received, including interference that may cause undesired operation.

Changes or modifications not expressly approved by the party responsible for compliance could void the user's authority to operate the equipment.

FCC Interference Statement for Class A EVM devices

NOTE: This equipment has been tested and found to comply with the limits for a Class A digital device, pursuant to part 15 of the FCC Rules. These limits are designed to provide reasonable protection against harmful interference when the equipment is operated in a commercial environment. This equipment generates, uses, and can radiate radio frequency energy and, if not installed and used in accordance with the instruction manual, may cause harmful interference to radio communications. Operation of this equipment in a residential area is likely to cause harmful interference in which case the user will be required to correct the interference at his own expense.

FCC Interference Statement for Class B EVM devices

NOTE: This equipment has been tested and found to comply with the limits for a Class B digital device, pursuant to part 15 of the FCC Rules. These limits are designed to provide reasonable protection against harmful interference in a residential installation. This equipment generates, uses and can radiate radio frequency energy and, if not installed and used in accordance with the instructions, may cause harmful interference to radio communications. However, there is no guarantee that interference will not occur in a particular installation. If this equipment does cause harmful interference to radio or television reception, which can be determined by turning the equipment off and on, the user is encouraged to try to correct the interference by one or more of the following measures:

- Reorient or relocate the receiving antenna.
- Increase the separation between the equipment and receiver.
- Connect the equipment into an outlet on a circuit different from that to which the receiver is connected.
- Consult the dealer or an experienced radio/TV technician for help.

3.2 Canada

3.2.1 For EVMs issued with an Industry Canada Certificate of Conformance to RSS-210 or RSS-247

Concerning EVMs Including Radio Transmitters:

This device complies with Industry Canada license-exempt RSSs. Operation is subject to the following two conditions:

(1) this device may not cause interference, and (2) this device must accept any interference, including interference that may cause undesired operation of the device.

Concernant les EVMs avec appareils radio:

Le présent appareil est conforme aux CNR d'Industrie Canada applicables aux appareils radio exempts de licence. L'exploitation est autorisée aux deux conditions suivantes: (1) l'appareil ne doit pas produire de brouillage, et (2) l'utilisateur de l'appareil doit accepter tout brouillage radioélectrique subi, même si le brouillage est susceptible d'en compromettre le fonctionnement.

Concerning EVMs Including Detachable Antennas:

Under Industry Canada regulations, this radio transmitter may only operate using an antenna of a type and maximum (or lesser) gain approved for the transmitter by Industry Canada. To reduce potential radio interference to other users, the antenna type and its gain should be so chosen that the equivalent isotropically radiated power (e.i.r.p.) is not more than that necessary for successful communication. This radio transmitter has been approved by Industry Canada to operate with the antenna types listed in the user guide with the maximum permissible gain and required antenna impedance for each antenna type indicated. Antenna types not included in this list, having a gain greater than the maximum gain indicated for that type, are strictly prohibited for use with this device.

Concernant les EVMs avec antennes détachables

Conformément à la réglementation d'Industrie Canada, le présent émetteur radio peut fonctionner avec une antenne d'un type et d'un gain maximal (ou inférieur) approuvé pour l'émetteur par Industrie Canada. Dans le but de réduire les risques de brouillage radioélectrique à l'intention des autres utilisateurs, il faut choisir le type d'antenne et son gain de sorte que la puissance isotrope rayonnée équivalente (p.i.r.e.) ne dépasse pas l'intensité nécessaire à l'établissement d'une communication satisfaisante. Le présent émetteur radio a été approuvé par Industrie Canada pour fonctionner avec les types d'antenne énumérés dans le manuel d'usage et ayant un gain admissible maximal et l'impédance requise pour chaque type d'antenne. Les types d'antenne non inclus dans cette liste, ou dont le gain est supérieur au gain maximal indiqué, sont strictement interdits pour l'exploitation de l'émetteur.

3.3 Japan

3.3.1 *Notice for EVMs delivered in Japan:* Please see http://www.tij.co.jp/lstds/ti_ja/general/eStore/notice_01.page 日本国内に輸入される評価用キット、ボードについては、次のところをご覧ください。
http://www.tij.co.jp/lstds/ti_ja/general/eStore/notice_01.page

3.3.2 *Notice for Users of EVMs Considered "Radio Frequency Products" in Japan:* EVMs entering Japan may not be certified by TI as conforming to Technical Regulations of Radio Law of Japan.

If User uses EVMs in Japan, not certified to Technical Regulations of Radio Law of Japan, User is required to follow the instructions set forth by Radio Law of Japan, which includes, but is not limited to, the instructions below with respect to EVMs (which for the avoidance of doubt are stated strictly for convenience and should be verified by User):

1. Use EVMs in a shielded room or any other test facility as defined in the notification #173 issued by Ministry of Internal Affairs and Communications on March 28, 2006, based on Sub-section 1.1 of Article 6 of the Ministry's Rule for Enforcement of Radio Law of Japan,
2. Use EVMs only after User obtains the license of Test Radio Station as provided in Radio Law of Japan with respect to EVMs, or
3. Use of EVMs only after User obtains the Technical Regulations Conformity Certification as provided in Radio Law of Japan with respect to EVMs. Also, do not transfer EVMs, unless User gives the same notice above to the transferee. Please note that if User does not follow the instructions above, User will be subject to penalties of Radio Law of Japan.

【無線電波を送信する製品の開発キットをお使いになる際の注意事項】 開発キットの中には技術基準適合証明を受けていないものがあります。技術適合証明を受けていないものご使用に際しては、電波法遵守のため、以下のいずれかの措置を取っていただく必要がありますのでご注意ください。

1. 電波法施行規則第6条第1項第1号に基づく平成18年3月28日総務省告示第173号で定められた電波暗室等の試験設備でご使用いただく。
2. 実験局の免許を取得後ご使用いただく。
3. 技術基準適合証明を取得後ご使用いただく。

なお、本製品は、上記の「ご使用にあたっての注意」を譲渡先、移転先に通知しない限り、譲渡、移転できないものとします。

上記を遵守頂けない場合は、電波法の罰則が適用される可能性があることをご留意ください。日本テキサス・インスツルメンツ株式会社
東京都新宿区西新宿 6 丁目 2 4 番 1 号
西新宿三井ビル

3.3.3 *Notice for EVMs for Power Line Communication:* Please see http://www.tij.co.jp/llds/ti_ja/general/eStore/notice_02.page
電力線搬送波通信についての開発キットをお使いになる際の注意事項については、次のところをご覧ください。 http://www.tij.co.jp/llds/ti_ja/general/eStore/notice_02.page

3.4 *European Union*

3.4.1 *For EVMs subject to EU Directive 2014/30/EU (Electromagnetic Compatibility Directive):*

This is a class A product intended for use in environments other than domestic environments that are connected to a low-voltage power-supply network that supplies buildings used for domestic purposes. In a domestic environment this product may cause radio interference in which case the user may be required to take adequate measures.

4 *EVM Use Restrictions and Warnings:*

4.1 EVMS ARE NOT FOR USE IN FUNCTIONAL SAFETY AND/OR SAFETY CRITICAL EVALUATIONS, INCLUDING BUT NOT LIMITED TO EVALUATIONS OF LIFE SUPPORT APPLICATIONS.

4.2 User must read and apply the user guide and other available documentation provided by TI regarding the EVM prior to handling or using the EVM, including without limitation any warning or restriction notices. The notices contain important safety information related to, for example, temperatures and voltages.

4.3 *Safety-Related Warnings and Restrictions:*

4.3.1 User shall operate the EVM within TI's recommended specifications and environmental considerations stated in the user guide, other available documentation provided by TI, and any other applicable requirements and employ reasonable and customary safeguards. Exceeding the specified performance ratings and specifications (including but not limited to input and output voltage, current, power, and environmental ranges) for the EVM may cause personal injury or death, or property damage. If there are questions concerning performance ratings and specifications, User should contact a TI field representative prior to connecting interface electronics including input power and intended loads. Any loads applied outside of the specified output range may also result in unintended and/or inaccurate operation and/or possible permanent damage to the EVM and/or interface electronics. Please consult the EVM user guide prior to connecting any load to the EVM output. If there is uncertainty as to the load specification, please contact a TI field representative. During normal operation, even with the inputs and outputs kept within the specified allowable ranges, some circuit components may have elevated case temperatures. These components include but are not limited to linear regulators, switching transistors, pass transistors, current sense resistors, and heat sinks, which can be identified using the information in the associated documentation. When working with the EVM, please be aware that the EVM may become very warm.

4.3.2 EVMs are intended solely for use by technically qualified, professional electronics experts who are familiar with the dangers and application risks associated with handling electrical mechanical components, systems, and subsystems. User assumes all responsibility and liability for proper and safe handling and use of the EVM by User or its employees, affiliates, contractors or designees. User assumes all responsibility and liability to ensure that any interfaces (electronic and/or mechanical) between the EVM and any human body are designed with suitable isolation and means to safely limit accessible leakage currents to minimize the risk of electrical shock hazard. User assumes all responsibility and liability for any improper or unsafe handling or use of the EVM by User or its employees, affiliates, contractors or designees.

4.4 User assumes all responsibility and liability to determine whether the EVM is subject to any applicable international, federal, state, or local laws and regulations related to User's handling and use of the EVM and, if applicable, User assumes all responsibility and liability for compliance in all respects with such laws and regulations. User assumes all responsibility and liability for proper disposal and recycling of the EVM consistent with all applicable international, federal, state, and local requirements.

5. *Accuracy of Information:* To the extent TI provides information on the availability and function of EVMs, TI attempts to be as accurate as possible. However, TI does not warrant the accuracy of EVM descriptions, EVM availability or other information on its websites as accurate, complete, reliable, current, or error-free.

6. *Disclaimers:*
- 6.1 EXCEPT AS SET FORTH ABOVE, EVMS AND ANY MATERIALS PROVIDED WITH THE EVM (INCLUDING, BUT NOT LIMITED TO, REFERENCE DESIGNS AND THE DESIGN OF THE EVM ITSELF) ARE PROVIDED "AS IS" AND "WITH ALL FAULTS." TI DISCLAIMS ALL OTHER WARRANTIES, EXPRESS OR IMPLIED, REGARDING SUCH ITEMS, INCLUDING BUT NOT LIMITED TO ANY EPIDEMIC FAILURE WARRANTY OR IMPLIED WARRANTIES OF MERCHANTABILITY OR FITNESS FOR A PARTICULAR PURPOSE OR NON-INFRINGEMENT OF ANY THIRD PARTY PATENTS, COPYRIGHTS, TRADE SECRETS OR OTHER INTELLECTUAL PROPERTY RIGHTS.
- 6.2 EXCEPT FOR THE LIMITED RIGHT TO USE THE EVM SET FORTH HEREIN, NOTHING IN THESE TERMS SHALL BE CONSTRUED AS GRANTING OR CONFERRING ANY RIGHTS BY LICENSE, PATENT, OR ANY OTHER INDUSTRIAL OR INTELLECTUAL PROPERTY RIGHT OF TI, ITS SUPPLIERS/LICENSORS OR ANY OTHER THIRD PARTY, TO USE THE EVM IN ANY FINISHED END-USER OR READY-TO-USE FINAL PRODUCT, OR FOR ANY INVENTION, DISCOVERY OR IMPROVEMENT, REGARDLESS OF WHEN MADE, CONCEIVED OR ACQUIRED.
7. *USER'S INDEMNITY OBLIGATIONS AND REPRESENTATIONS.* USER WILL DEFEND, INDEMNIFY AND HOLD TI, ITS LICENSORS AND THEIR REPRESENTATIVES HARMLESS FROM AND AGAINST ANY AND ALL CLAIMS, DAMAGES, LOSSES, EXPENSES, COSTS AND LIABILITIES (COLLECTIVELY, "CLAIMS") ARISING OUT OF OR IN CONNECTION WITH ANY HANDLING OR USE OF THE EVM THAT IS NOT IN ACCORDANCE WITH THESE TERMS. THIS OBLIGATION SHALL APPLY WHETHER CLAIMS ARISE UNDER STATUTE, REGULATION, OR THE LAW OF TORT, CONTRACT OR ANY OTHER LEGAL THEORY, AND EVEN IF THE EVM FAILS TO PERFORM AS DESCRIBED OR EXPECTED.
8. *Limitations on Damages and Liability:*
- 8.1 *General Limitations.* IN NO EVENT SHALL TI BE LIABLE FOR ANY SPECIAL, COLLATERAL, INDIRECT, PUNITIVE, INCIDENTAL, CONSEQUENTIAL, OR EXEMPLARY DAMAGES IN CONNECTION WITH OR ARISING OUT OF THESE TERMS OR THE USE OF THE EVMS , REGARDLESS OF WHETHER TI HAS BEEN ADVISED OF THE POSSIBILITY OF SUCH DAMAGES. EXCLUDED DAMAGES INCLUDE, BUT ARE NOT LIMITED TO, COST OF REMOVAL OR REINSTALLATION, ANCILLARY COSTS TO THE PROCUREMENT OF SUBSTITUTE GOODS OR SERVICES, RETESTING, OUTSIDE COMPUTER TIME, LABOR COSTS, LOSS OF GOODWILL, LOSS OF PROFITS, LOSS OF SAVINGS, LOSS OF USE, LOSS OF DATA, OR BUSINESS INTERRUPTION. NO CLAIM, SUIT OR ACTION SHALL BE BROUGHT AGAINST TI MORE THAN TWELVE (12) MONTHS AFTER THE EVENT THAT GAVE RISE TO THE CAUSE OF ACTION HAS OCCURRED.
- 8.2 *Specific Limitations.* IN NO EVENT SHALL TI'S AGGREGATE LIABILITY FROM ANY USE OF AN EVM PROVIDED HEREUNDER, INCLUDING FROM ANY WARRANTY, INDEMNITY OR OTHER OBLIGATION ARISING OUT OF OR IN CONNECTION WITH THESE TERMS, , EXCEED THE TOTAL AMOUNT PAID TO TI BY USER FOR THE PARTICULAR EVM(S) AT ISSUE DURING THE PRIOR TWELVE (12) MONTHS WITH RESPECT TO WHICH LOSSES OR DAMAGES ARE CLAIMED. THE EXISTENCE OF MORE THAN ONE CLAIM SHALL NOT ENLARGE OR EXTEND THIS LIMIT.
9. *Return Policy.* Except as otherwise provided, TI does not offer any refunds, returns, or exchanges. Furthermore, no return of EVM(s) will be accepted if the package has been opened and no return of the EVM(s) will be accepted if they are damaged or otherwise not in a resalable condition. If User feels it has been incorrectly charged for the EVM(s) it ordered or that delivery violates the applicable order, User should contact TI. All refunds will be made in full within thirty (30) working days from the return of the components(s), excluding any postage or packaging costs.
10. *Governing Law:* These terms and conditions shall be governed by and interpreted in accordance with the laws of the State of Texas, without reference to conflict-of-laws principles. User agrees that non-exclusive jurisdiction for any dispute arising out of or relating to these terms and conditions lies within courts located in the State of Texas and consents to venue in Dallas County, Texas. Notwithstanding the foregoing, any judgment may be enforced in any United States or foreign court, and TI may seek injunctive relief in any United States or foreign court.

IMPORTANT NOTICE FOR TI DESIGN INFORMATION AND RESOURCES

Texas Instruments Incorporated ("TI") technical, application or other design advice, services or information, including, but not limited to, reference designs and materials relating to evaluation modules, (collectively, "TI Resources") are intended to assist designers who are developing applications that incorporate TI products; by downloading, accessing or using any particular TI Resource in any way, you (individually or, if you are acting on behalf of a company, your company) agree to use it solely for this purpose and subject to the terms of this Notice.

TI's provision of TI Resources does not expand or otherwise alter TI's applicable published warranties or warranty disclaimers for TI products, and no additional obligations or liabilities arise from TI providing such TI Resources. TI reserves the right to make corrections, enhancements, improvements and other changes to its TI Resources.

You understand and agree that you remain responsible for using your independent analysis, evaluation and judgment in designing your applications and that you have full and exclusive responsibility to assure the safety of your applications and compliance of your applications (and of all TI products used in or for your applications) with all applicable regulations, laws and other applicable requirements. You represent that, with respect to your applications, you have all the necessary expertise to create and implement safeguards that (1) anticipate dangerous consequences of failures, (2) monitor failures and their consequences, and (3) lessen the likelihood of failures that might cause harm and take appropriate actions. You agree that prior to using or distributing any applications that include TI products, you will thoroughly test such applications and the functionality of such TI products as used in such applications. TI has not conducted any testing other than that specifically described in the published documentation for a particular TI Resource.

You are authorized to use, copy and modify any individual TI Resource only in connection with the development of applications that include the TI product(s) identified in such TI Resource. NO OTHER LICENSE, EXPRESS OR IMPLIED, BY ESTOPPEL OR OTHERWISE TO ANY OTHER TI INTELLECTUAL PROPERTY RIGHT, AND NO LICENSE TO ANY TECHNOLOGY OR INTELLECTUAL PROPERTY RIGHT OF TI OR ANY THIRD PARTY IS GRANTED HEREIN, including but not limited to any patent right, copyright, mask work right, or other intellectual property right relating to any combination, machine, or process in which TI products or services are used. Information regarding or referencing third-party products or services does not constitute a license to use such products or services, or a warranty or endorsement thereof. Use of TI Resources may require a license from a third party under the patents or other intellectual property of the third party, or a license from TI under the patents or other intellectual property of TI.

TI RESOURCES ARE PROVIDED "AS IS" AND WITH ALL FAULTS. TI DISCLAIMS ALL OTHER WARRANTIES OR REPRESENTATIONS, EXPRESS OR IMPLIED, REGARDING TI RESOURCES OR USE THEREOF, INCLUDING BUT NOT LIMITED TO ACCURACY OR COMPLETENESS, TITLE, ANY EPIDEMIC FAILURE WARRANTY AND ANY IMPLIED WARRANTIES OF MERCHANTABILITY, FITNESS FOR A PARTICULAR PURPOSE, AND NON-INFRINGEMENT OF ANY THIRD PARTY INTELLECTUAL PROPERTY RIGHTS.

TI SHALL NOT BE LIABLE FOR AND SHALL NOT DEFEND OR INDEMNIFY YOU AGAINST ANY CLAIM, INCLUDING BUT NOT LIMITED TO ANY INFRINGEMENT CLAIM THAT RELATES TO OR IS BASED ON ANY COMBINATION OF PRODUCTS EVEN IF DESCRIBED IN TI RESOURCES OR OTHERWISE. IN NO EVENT SHALL TI BE LIABLE FOR ANY ACTUAL, DIRECT, SPECIAL, COLLATERAL, INDIRECT, PUNITIVE, INCIDENTAL, CONSEQUENTIAL OR EXEMPLARY DAMAGES IN CONNECTION WITH OR ARISING OUT OF TI RESOURCES OR USE THEREOF, AND REGARDLESS OF WHETHER TI HAS BEEN ADVISED OF THE POSSIBILITY OF SUCH DAMAGES.

You agree to fully indemnify TI and its representatives against any damages, costs, losses, and/or liabilities arising out of your non-compliance with the terms and provisions of this Notice.

This Notice applies to TI Resources. Additional terms apply to the use and purchase of certain types of materials, TI products and services. These include; without limitation, TI's standard terms for semiconductor products (<http://www.ti.com/sc/docs/stdterms.htm>), [evaluation modules](#), and [samples](http://www.ti.com/sc/docs/sampterm.htm) (<http://www.ti.com/sc/docs/sampterm.htm>).

Mailing Address: Texas Instruments, Post Office Box 655303, Dallas, Texas 75265
Copyright © 2018, Texas Instruments Incorporated