

REVISIONS					
P	LTR	DESCRIPTION	DATE	DMN	APVD
W	REV PER ECO	19-019228	4-17-20	CT	DM

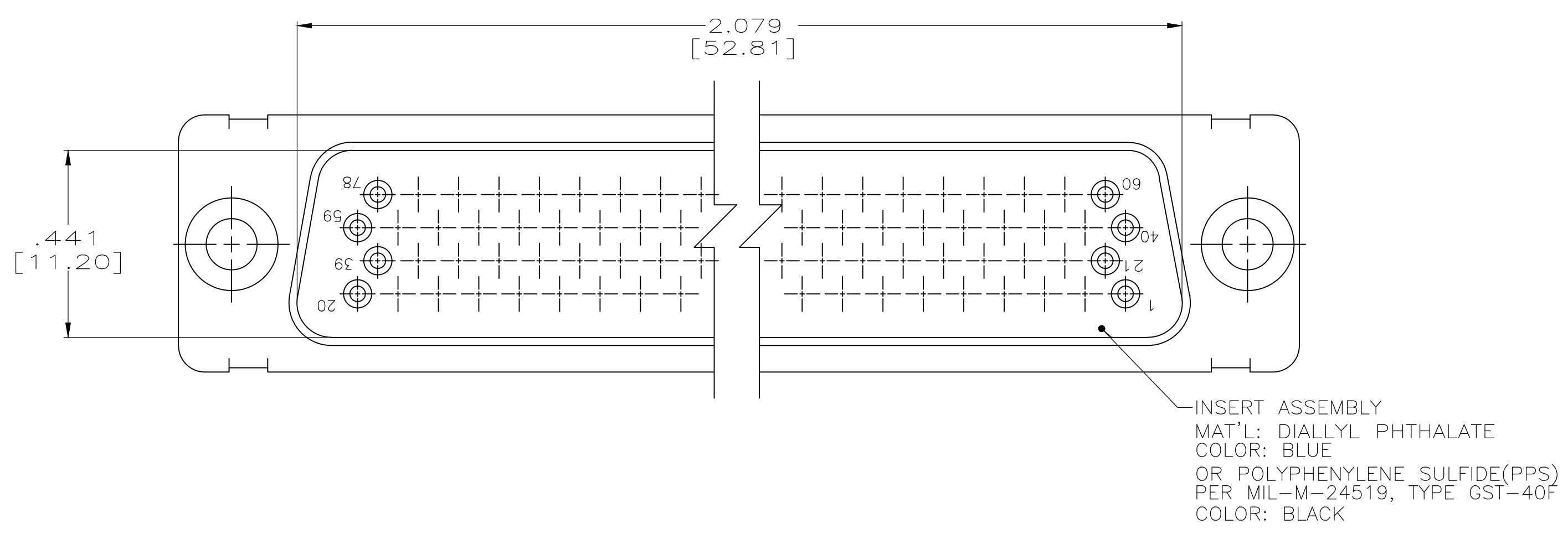

- 1. CONTACTS INCLUDED IN ASSEMBLY.
- △ MATL: STEEL, PER ASTM-A-109.
- △ FINISH: CADMIUM PER QQ-P-416.
- △ MATL: BRASS PER ASTM-B-36.
- △ FINISH: PLATED ZINC .00020 MIN THK PER ASTM-B-633. YELLOW CHROMATE FINISH.
- △ CONTACT
- BODY MAT'L: BERYLLIUM COPPER PER ASTM-B-197.
- BODY FINISH: PLATED GOLD, .000050 MIN THK PER MIL-G-45204 OVER NICKEL, .000050 MIN THK PER QQ-N-290.
- HOOD MAT'L: STAINLESS STEEL PER ASTM-A-240.
- HOOD FINISH: PASSIVATED PER QQ-P-35
- △ FINISH: PLATED GOLD, .000050 MIN THK PER MIL-G-45204 OVER COPPER FLASH
- △ FINISH: PLATED GOLD, .000050 MIN THK PER MIL-G-45204 OVER COPPER, .000100 MIN THK PER MIL-C-14550.
- △ CONTACT
- BODY MAT'L: BERYLLIUM COPPER PER ASTM-B-197.
- BODY FINISH: PLATED GOLD, .000050 MIN THK PER MIL-G-45204 OVER COPPER, .000100 MIN THK PER MIL-C-14550.
- HOOD MAT'L: COPPER ALLOY PER QQ-B-613.
- FINISH: PLATED GOLD, .000050 MIN THK PER MIL-G-45204 OVER COPPER, .000100 MIN THK PER MIL-C-14550.

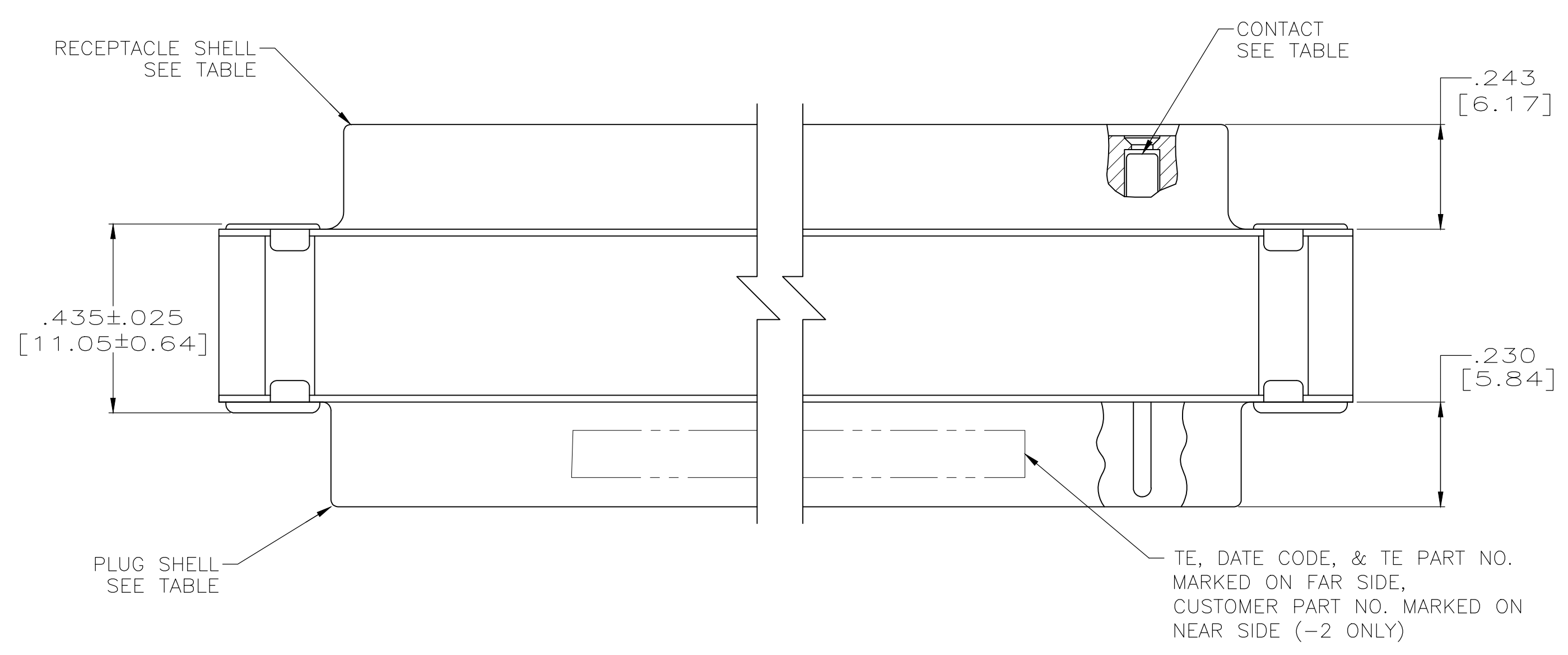
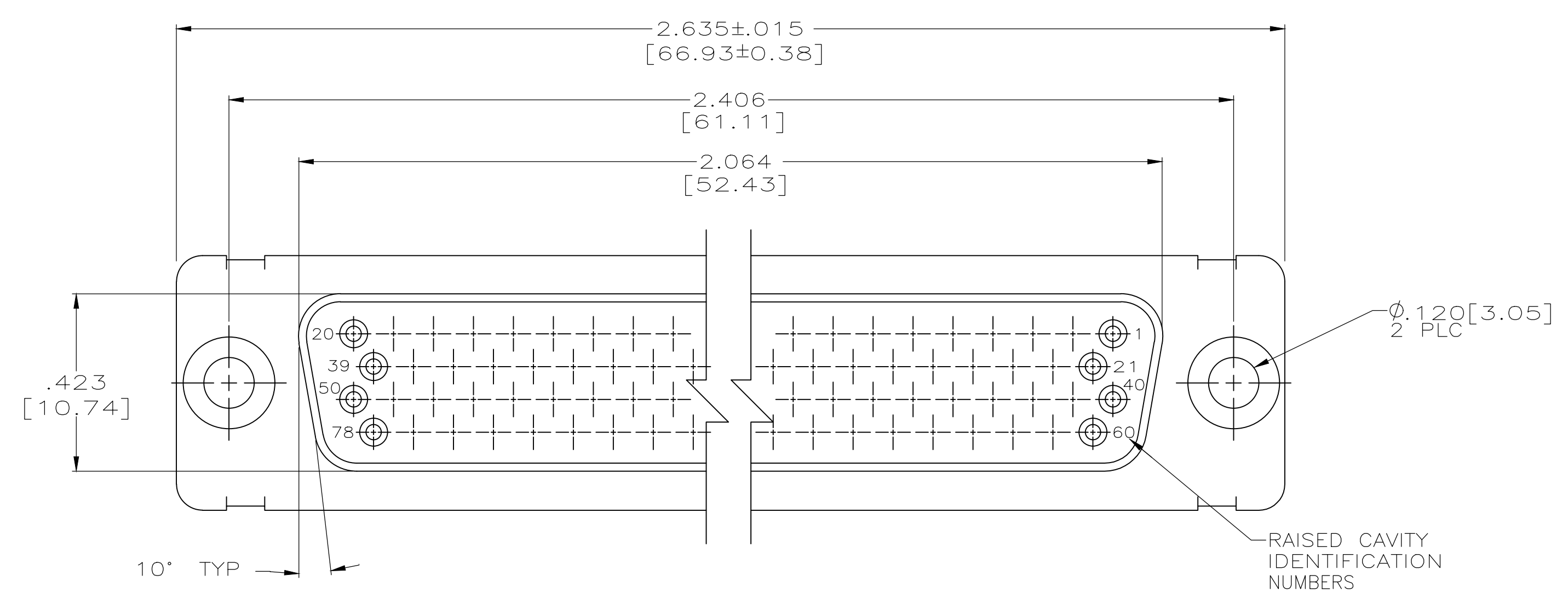
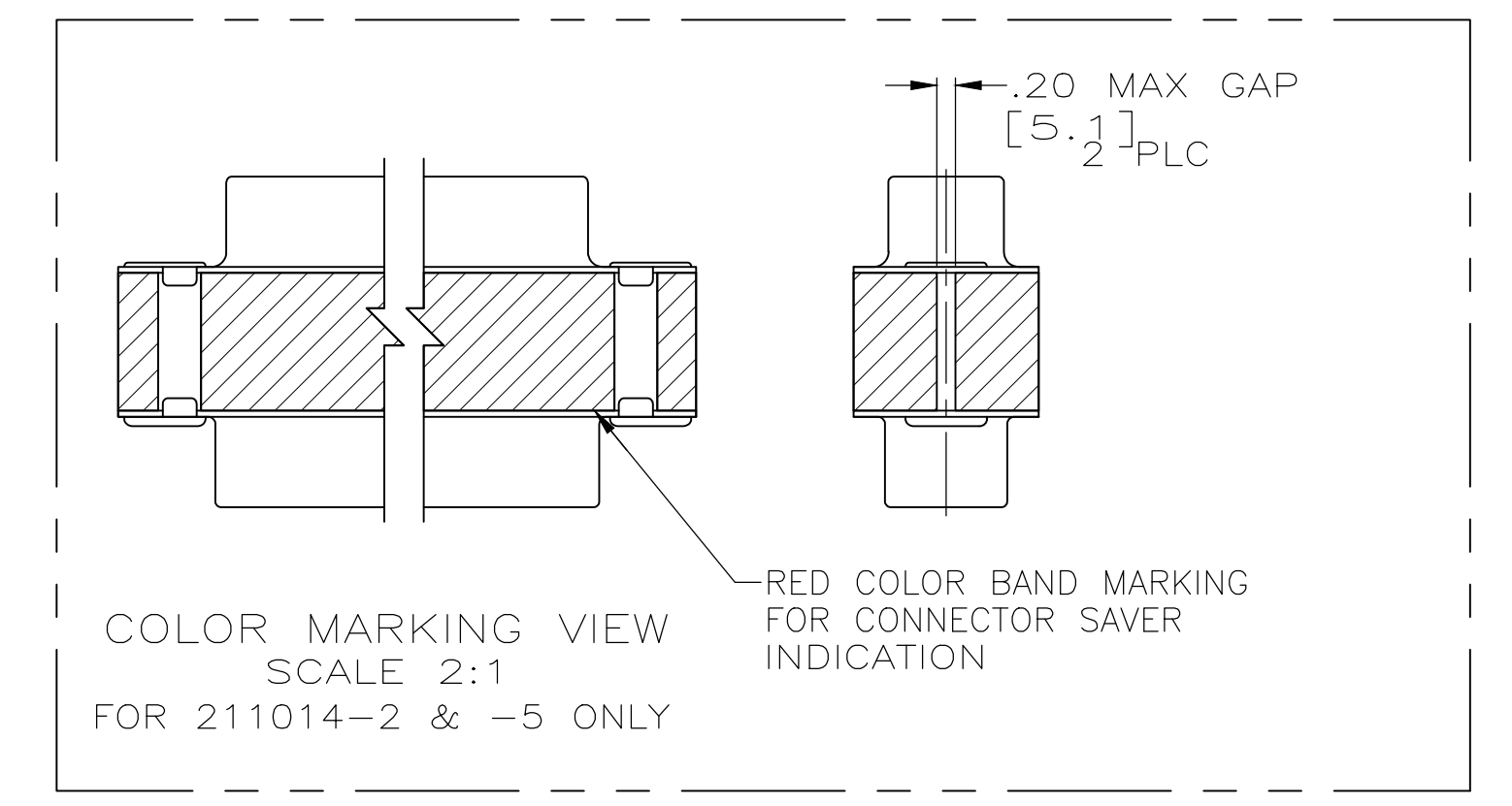
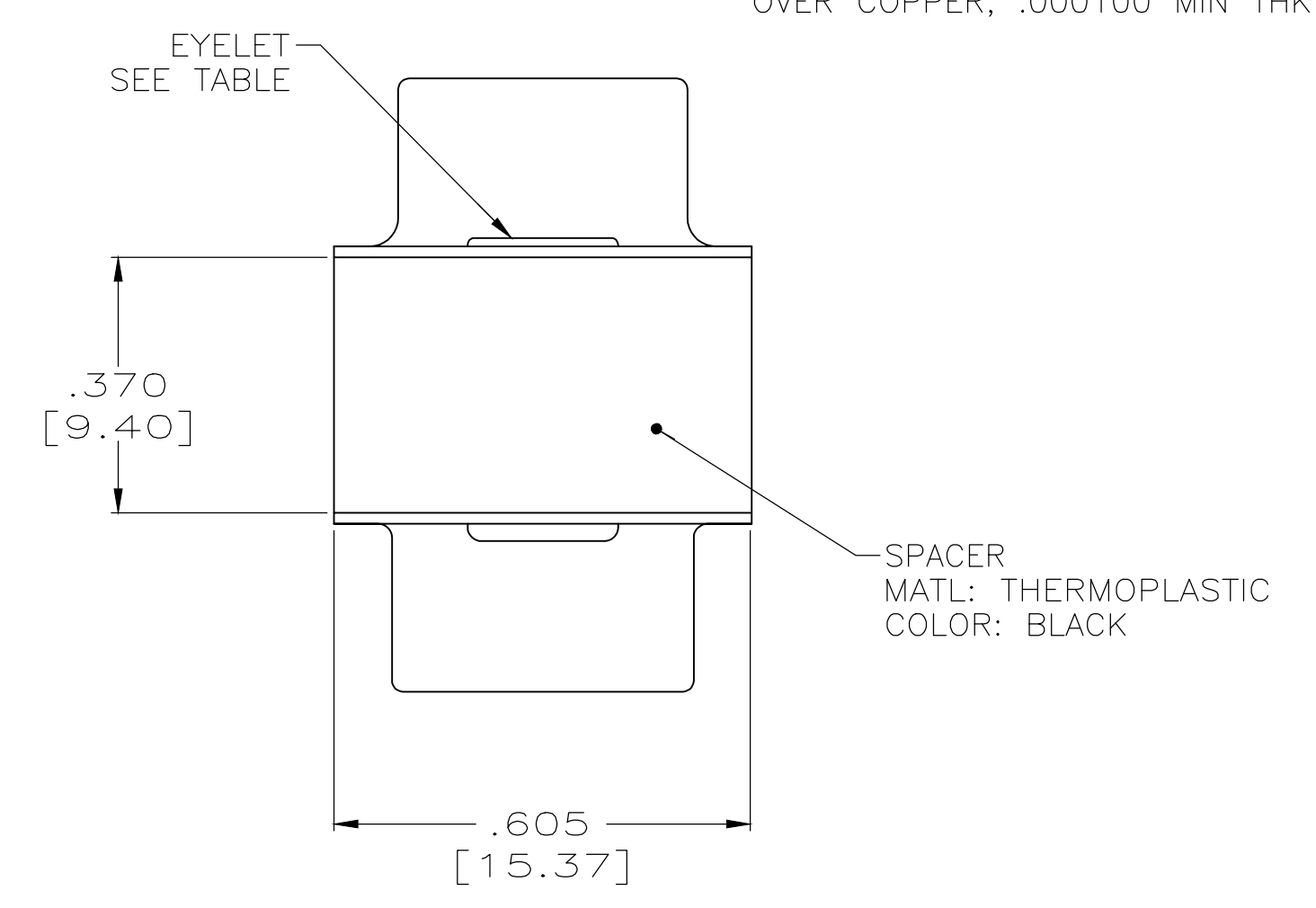

△ △	△ △	△	R10002677-0110	211014-5
△ △	△ △	△	-	211014-4
△ △	△ △	△	(1J02-110)	211014-2
△ △	△ △	△	-	211014-1
EYELET	SHELLS	CONTACT	CUSTOMER P/N	PART NO.

THIS DRAWING IS A CONTROLLED DOCUMENT.

DIMENSIONS: INCHES	TOLERANCES UNLESS OTHERWISE SPECIFIED:	0 PLC ± -	1 PLC ± -	2 PLC ± -	3 PLC ± .005 [0.13]	4 PLC ± -	ANGLES ± -
--------------------	--	-----------	-----------	-----------	---------------------	-----------	------------

MATERIAL	FINISH	WEIGHT	0.000000	SIZE	A1	CAGE CODE	00779	DRAWING NO.	211014	RESTRICTED TO	-
----------	--------	--------	----------	------	----	-----------	-------	-------------	--------	---------------	---

CUSTOMER DRAWING SCALE 4:1 SHEET 1 OF 1 REV W