

Power Relay F7 A Latching

- Magnetically latched, ISO plug-in relay
- One coil with set and reset function
- Pin assignment similar to ISO 7588 part 1
- Customized versions available (colour, parallel or serial components etc.)
- Mini version (40A with 6.3mm terminals) available on request



3D136L_fw2

Typical applications

Cross carline, e.g. Power outlet switch off, start-stop, energy management

Contact Data

Contact arrangement	1 form A, 1 NO
Rated voltage	12VDC
Limiting continuous current	
23°C	80A
85°C	60A
125°C	35A
Limiting making current ¹⁾	300A
Limiting breaking current	70A
Limiting short-time current overload current, ISO 8820-3 ²⁾	1.35 x 50A, 1800s 2.00 x 50A, 5s 3.50 x 50A, 0.5s 6.00 x 50A, 0.1s
Contact material	Silver based
Min. recommended contact load ³⁾	1A at 5VDC
Initial voltage drop, NO contact at 10A, typ./max.	15/300mV
Frequency of operation at nominal load	6 ops./min (0.1Hz)
Set/reset time typ.	2/1ms
Electrical endurance	
at cyclic temperature -40/+23/+85°C, 14VDC, 2s (on), 2s (off)	
resistive load 300A (on)/ 30A (off)	>2x10 ⁵ ops
motor load L=0.2mH, 200A (on)/ 40A (off)	>1x10 ⁵ ops
Mechanical endurance	>1x10 ⁷ ops

Coil Data

Magnetic system	bistable (one coil system)								
Rated coil voltage	12VDC								
Min./Max. energization duration	10ms/100ms								
Polarity for set/reset energization	<table border="0"> <tr> <td>set</td> <td>reset</td> </tr> <tr> <td>-</td> <td>-</td> </tr> <tr> <td>+</td> <td>+</td> </tr> <tr> <td>pin 2</td> <td>pin 1</td> </tr> </table>	set	reset	-	-	+	+	pin 2	pin 1
set	reset								
-	-								
+	+								
pin 2	pin 1								
Max. coil temperature	155°C								

Coil versions, DC coil

Coil code	Rated voltage VDC	Operate voltage VDC	Release voltage VDC	Coil resistance Ω±10%	Impulse length ms
031	12	6	6	25	10-100

All figures are given for coil without pre-energization, at ambient temperature +23°C.

Insulation Data

Initial dielectric strength	
between open contacts	500V _{rms}
between contact and coil	500V _{rms}
between adjacent contacts	500V _{rms}

Load dump test

ISO 7637-1 (12VDC), test pulse 5	V _s =+86.5VDC
ISO 7637-2 (24VDC), test pulse 5	V _s =+200VDC

- 1) The values apply to a resistive or inductive load with suitable spark suppression and at maximum 14VDC for 12VDC load voltages. For a load current duration of maximum 3s for a make/break ratio of 1:10.
- 2) Current and time are compatible with circuit protection by a typical 50A automotive fuse. Relay will make, carry and break the specified current.
- 3) See chapter Diagnostics of Relays in our Application Notes or consult the internet at <http://relays.te.com/appnotes/>

Max. DC load breaking capacity

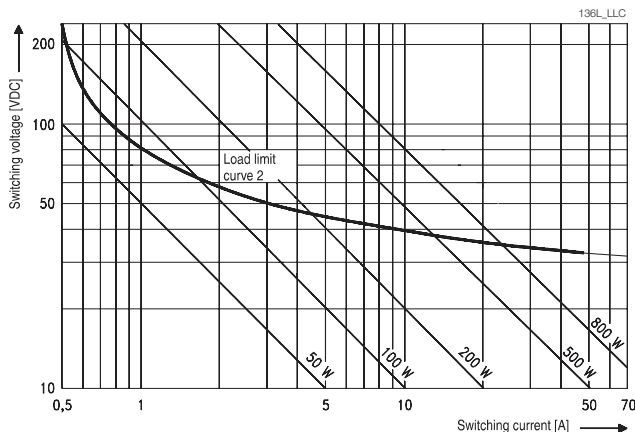

Coil operating range

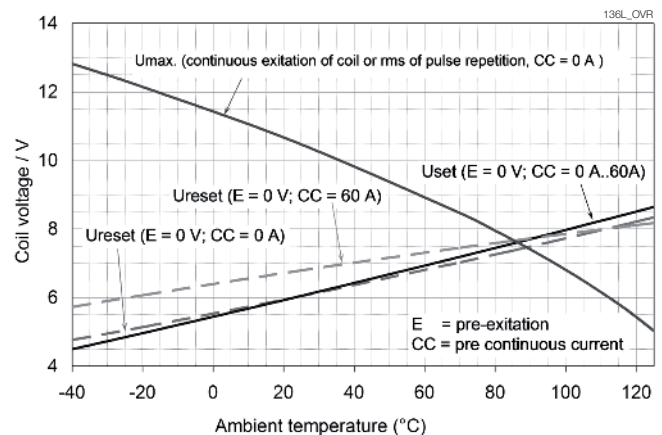

Power Relay F7 A Latching (Continued)

Other Data	
EU RoHS/ELV compliance	compliant
Protection to heat and fire according UL94	HB or better ⁴⁾
Climatic cycling with condensation	
EN ISO 6988	6 cycles, storage 8/16h
Temperature cycling	
IEC 60068-2-14, Nb	10 cycles, -40/+85°C (5°C/min)
Damp heat cyclic	
IEC 60068-2-30, Db, Variant 1	6 cycles, upper air temp. 55°C
Damp heat constant, IEC 60068-2-3, Ca	
	56 days
Category of environmental protection, IEC 61810	
	RT I – dustproof
Degree of protection, IEC 60529	
	IP54 – dustproof
Vibration resistance (functional)	
IEC 60068-2-6 (sine sweep)	10 to 500Hz, min. 10g ⁵⁾
Shock resistance (functional)	
IEC 60068-2-27 (half sine)	6ms, min. 30g ⁵⁾
Drop test, free fall, IEC 60068-2-32	
	1m onto concrete ⁶⁾

Other Data (continued)	
Terminal type	Plug-in, QC
Cover retention	
axial force	150N
pull force	200N
push force	200N
Terminal retention	
pull force	100N
push force	100N
Weight	approx. 35g (1.2oz)

- 4) Refers to used materials.
- 5) No change in the switching state >10µs. Valid for open contacts, for closed contact values significantly higher.
- 6) Contact status can change due to drop.

Accessories	
For details see datasheet	Connector for Maxi ISO Relays

Dimensions

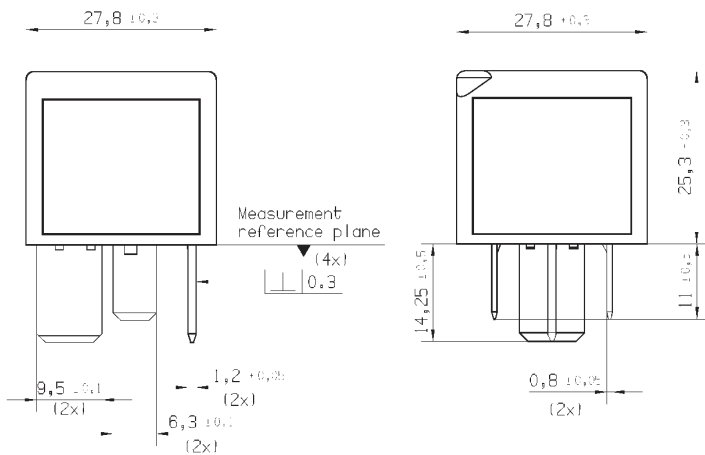

View of the terminals (bottom view)

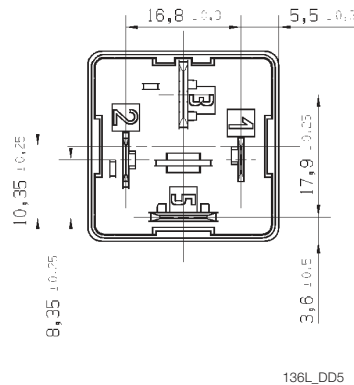

Terminal Assignment

1 form A, NO latching

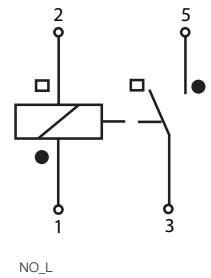

Product code structure

Typical product code **V23136 -L 0 031 -D642**

Type	V23136 Power Relay F7 A
Feature	L Latching
Cover	0 Standard
Coil	031 12VDC
Terminal/arrangement	D642 Standard version Xnnn Customized version

Other types on request.

Product code	Arrangement	Feature	Cover	Circuit	Coil	Contact material	Terminals	Part number
V23136-L0031-D642	1 form A, 1 NO	Latching	Standard	NOL	12VDC	Silver based	Plug-in, QC	4-1904060-6

Other types on request.