



Low Power Multiclock Generator with XO AK8137A

Features

- 25MHz Crystal Input
- One 25MHz-Reference Output
- Selectable Clock out Frequencies:
 - 100, 133, 166, 200MHz
 - 96MHz
 - 100MHz
 - 25MHz
- Low Jitter Performance
 - Cycle to Cycle Jitter:
 - 85 psec at CPU_C
 - 125 psec at SATA_C
 - 250 psec at UBS_C
- Low Current Consumption:
 - 37mA (Typ.) at 3.3V
- Supply Voltage:
 - 3.0 – 3.6V
- Operating Temperature Range:
 - 20 to +85°C
- Package:
 - 20-pin SSOP (Lead free, Halogen free)

Description

The AK8137A is a member of AKM's low power multi clock generator family designed for a feature rich DTV or STB, requiring a range of system clocks with high performance. The AK8137A generates different frequency clocks from a 25 MHz crystal oscillator and provides them to up to four outputs configured by pin-setting. PLL in AK8137A are derived from AKM's long-term-experienced clock device technology, and enable clock output to perform low jitter and to operate with very low current consumption. The AK8137A is available in a 20-pin SSOP package.

Applications

- Set-Top-Boxes

Block Diagram

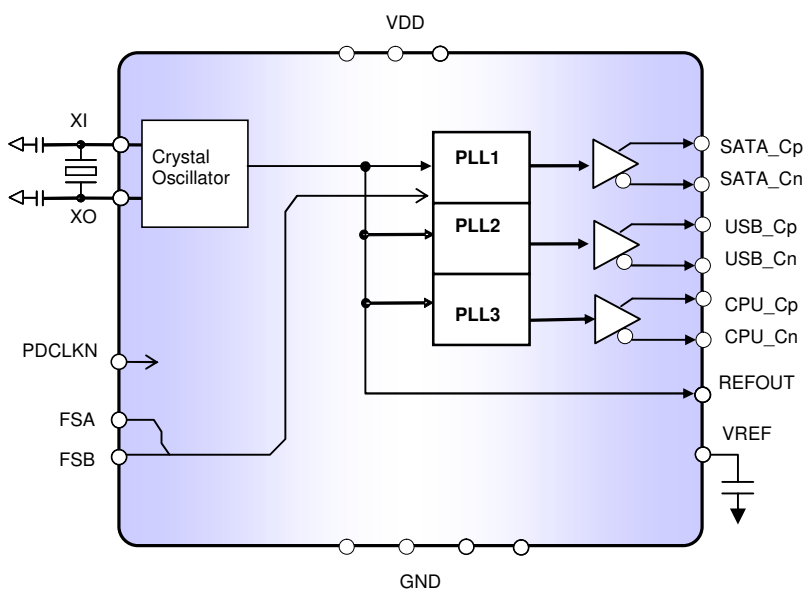

AK8137A Multi Clock Generator

Pin Descriptions

Package: 20-Pin SSOP(Top View)

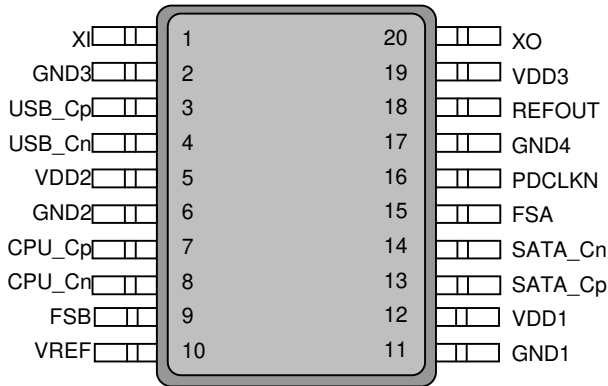

Pin No.	Pin Name	Pin Type	Description
1	XI	AI	Crystal connection, Connect to 25.000MHz crystal
2	GND3	PWR	Ground 3
3	USB_Cp	DO	96MHz Clock output for USB
4	USB_Cn	DO	
5	VDD2	PWR	Power Supply 2
6	GND2	PWR	Ground 2
7	CPU_Cp	DO	Clock output for CPU See Table 1 for its selectable frequency
8	CPU_Cn	DO	
9	FSB	DI	CPU Clock select 360k Ω internal pull-up.
10	VREF	AO	VREF Pin. Connect 1uF capacitor.
11	GND1	PWR	Ground 1
12	VDD1	PWR	Power Supply 1
13	SATA_Cp	DO	100MHz Clock output for SATA
14	SATA_Cn	DO	
15	FSA	DI	CPU Clock select 360k Ω internal pull-up.
16	PDCLKN	DI	Clock Output Control H: Power Down Disable, L: Power Down Enable 500k Ω internal pull-up.
17	GND4	PWR	Ground4
18	REFOUT	DO	Reference Clock Output 25.000MHz Crystal
19	VDD3	PWR	Power Supply 3
20	XO	AO	Crystal connection, Connect to 25.000MHz crystal

Ordering Information

Part Number	Marking	Shipping Packaging	Package	Temperature Range
AK8137A	8137A	Tape and Reel	20-pin SSOP	-20 to 85 °C

Absolute Maximum Rating

Over operating free-air temperature range unless otherwise noted ⁽¹⁾

Items	Symbol	Ratings	Unit
Supply voltage	VDD	-0.3 to 4.6	V
Input voltage	V _{in}	VSS-0.3 to VDD+ 0.3	V
Input current (any pins except supplies)	I _{IN}	± 10	mA
Storage temperature	T _{stg}	-55 to 130	°C

Note

(1) Stress beyond those listed under “Absolute Maximum Ratings” may cause permanent damage to the device. These are stress ratings only. Functional operation of the device at these or any other conditions beyond those indicated under “Recommended Operating Conditions” is not implied. Exposure to absolute-maximum-rating conditions for extended periods may affect device reliability. Electrical parameters are guaranteed only over the recommended operating temperature range.



ESD Sensitive Device

This device is manufactured on a CMOS process, therefore, generically susceptible to damage by excessive static voltage. Failure to observe proper handling and installation procedures can cause damage. AKM recommends that this device is handled with appropriate precautions.

Recommended Operation Conditions

Parameter	Symbol	Conditions	Min	Typ	Max	Unit
Operating temperature	T _a		-20		85	°C
Supply voltage ⁽¹⁾	VDD	Pin: VDD1,VDD2,VDD3	3.0	3.3	3.6	V
Output Load Capacitance	CL	Pin: Diff CLK pins See Figure.1			2	pF
Output Load Capacitance	C _{pl}	Pin: REFOUT			25	pF

Note:

(1) Power to VDD1, VDD2, VDD3 requires to be supplied from a single source. A decoupling capacitor for power supply line should be installed close to each VDD pin.

DC Characteristics

All specifications at VDD: over 3.0 to 3.6V, Ta: -20 to +85°C, 25MHz Crystal, unless otherwise noted

Parameter	Symbol	Conditions	MIN	TYP	MAX	Unit
High Level Input Voltage	V _{IH}	Pin: FSA,FSB,PDCLKN	0.7VDD			V
Low Level Input Voltage	V _{IL}	Pin: FSA,FSB,PDCLKN			0.3VDD	V
Input Current	I _L	Pin: FSA,FSB,PDCLKN	-20		+10	μA
High Level Output Voltage	V _{OH}	Pin: REFOUT I _{OH} =-4mA	0.8VDD			V
Low level Output Voltage	V _{OL}	Pin: REFOUT I _{OL} =+4mA			0.2VDD	V
Output impedance		Pin: Diff CLK pins TA=25°C,3.3V	14	20	26	Ω
VREF Voltage	V _{ref}	Pin: VREF	0.72	0.8	0.88	V
Current Consumption 1	I _{DD1}	No load Clock out selection by note (1) VDD=3.3V, Ta=25°C		37		mA
Current Consumption 2	I _{DD2}	On load (2) Clock out selection by note (1) VDD=3.3V, Ta=25°C		48		mA
Current Consumption 3	I _{DDPD}	PDCLKN="L" Ta=25°C		50	250	μA

(1)CPU_Cp/n:200MHz, USB_Cp/n:96MHz, SATA_Cp/n: 100MHz

(2)Diff CLK pins: Figure1, REFOUT:Cpl=25pF

AC Characteristics

All specifications at VDD: over 3.0 to 3.6V, Ta: over -20 to +85°C, 25MHz Crystal, unless otherwise noted

Parameter	Symbol	Conditions	MIN	TYP	MAX	Unit
Crystal Clock Frequency	F _{osc}	Pin: XI,XO		25.000		MHz
Cycle to Cycle Jitter 1	Jit _{cycle-cycle1}	Pin: CPU_Cp, CPU_Cn ⁽¹⁾⁽²⁾	-85		+85	ps
Cycle to Cycle Jitter 2	Jit _{cycle-cycle2}	Pin: USB_Cp, USB_Cn ⁽¹⁾⁽²⁾	-250		+250	ps
Cycle to Cycle Jitter 3	Jit _{cycle-cycle3}	Pin: SATA_Cp,SATA_Cn ⁽¹⁾⁽²⁾	-125		+125	ps
Output Clock Duty Cycle	DtyCyc	Pin: Diff CLK Pins ⁽²⁾ Figure.3	45	50	55	%
		Pin: REFOUT ⁽³⁾	40	50	60	%
Output Clock Slew Rate	Slew _{rise_fall}	Diff CLK Pins ⁽²⁾ Figure3	2.5		8.0	V/ns
Slew rate matching	Slew _{ver}	Diff CLK Pins ⁽²⁾ Figure.2			20	%
Differential output swing	V _{swing}	Diff CLK Pins ⁽²⁾ Figure.3	300			mV
Crossing point voltage	V _{cross}	Diff CLK Pins ⁽²⁾ Figure.2	300		550	mV
Variation of Vcr	V _{cross_delta}	Diff CLK Pins ⁽²⁾ Figure.2			140	mV
Maximim output voltage	V _{max}	Diff CLK Pins ⁽²⁾ Figure.2			1.15	V
Minimum output voltage	V _{min}	Diff CLK Pins ⁽²⁾ Figure.2	-0.3			V
Output Clock Rise Time	T _{rise}	Pin: REFOUT ⁽³⁾		2.5	5.0	ns
Output Clock Fall Time	T _{fall}	Pin: REFOUT ⁽³⁾		2.5	5.0	ns
Output disable Time ⁽⁴⁾	T _{dis}	Pin: CLK Pins			300	ms
Power-up Time1 ⁽⁴⁾	T _{put1}	Pin: CLK Pins			150	ms
Power-up Time2 ⁽⁵⁾	T _{put2}	Pin: CLK Pins			150	ms

(1) 1000 sampling or more

(2) Measured with load condition shown in Figure.1

(3) Measured with load capacitance of 25pF

(4) Refer to Figure.5 on Power down sequence

(5) Refer to Figure.4 on Power On Reset sequence

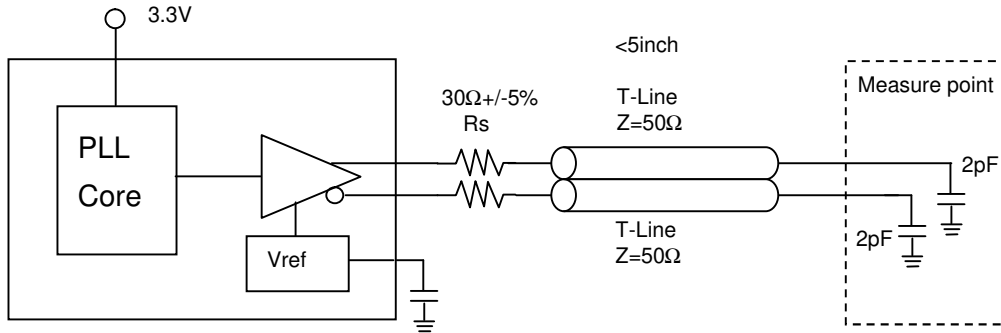

Figure.1 Diff Clocks Load condition

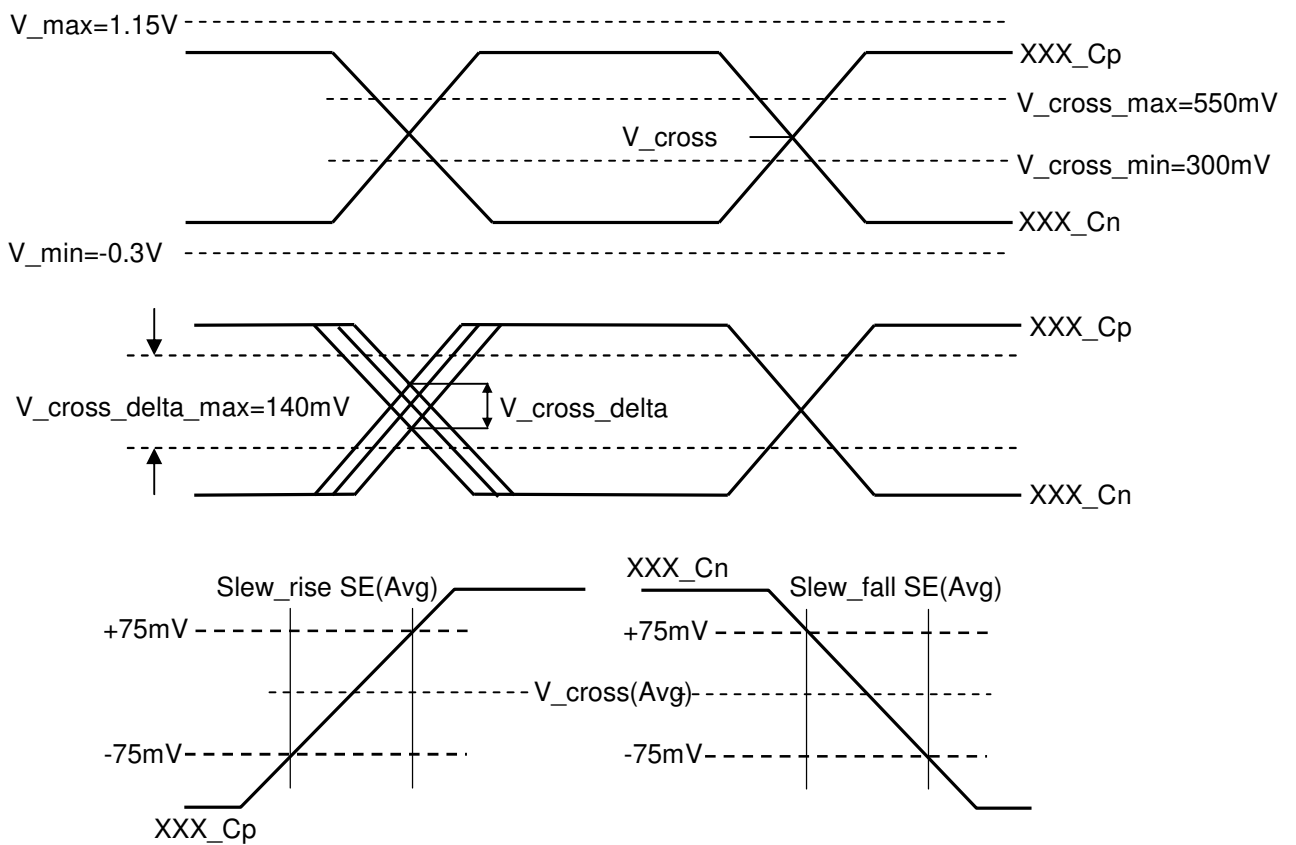

Figure.2 Single ended (SE) measurement waveforms

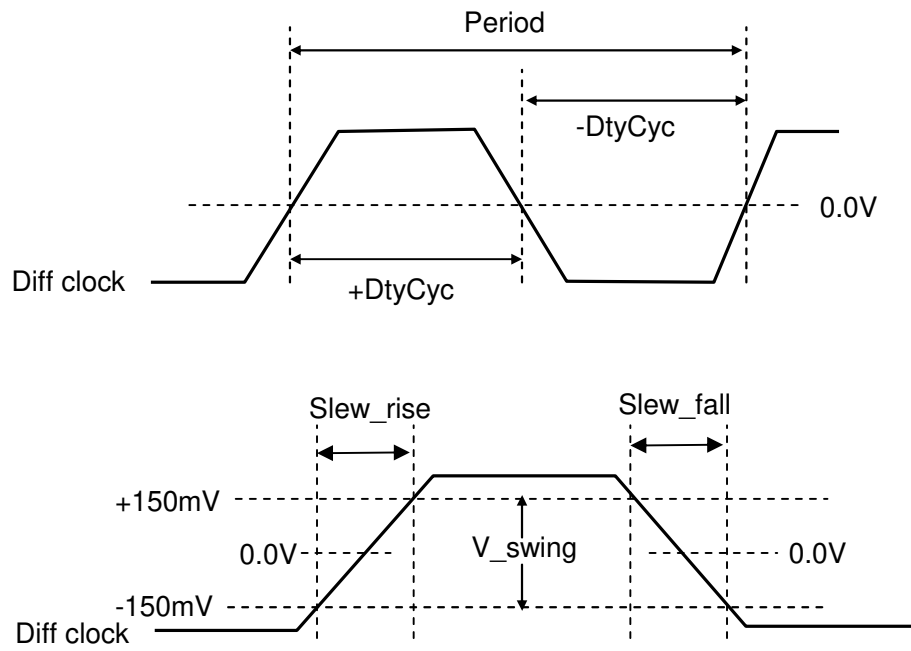

Figure.3 Differential (DIFF) measurement waveforms

Functional Description

Power On Reset

AK8137A has the POR(Power On Reset) circuit. In power up, the POR works and the register is set to the initial value and all clock output becomes enable without glitch.

Note1) The assumption power start time to reach 90 % of VDD is within 20 ms.

Note2) The first register setting should be done after the 150 ms elapse after the power on.

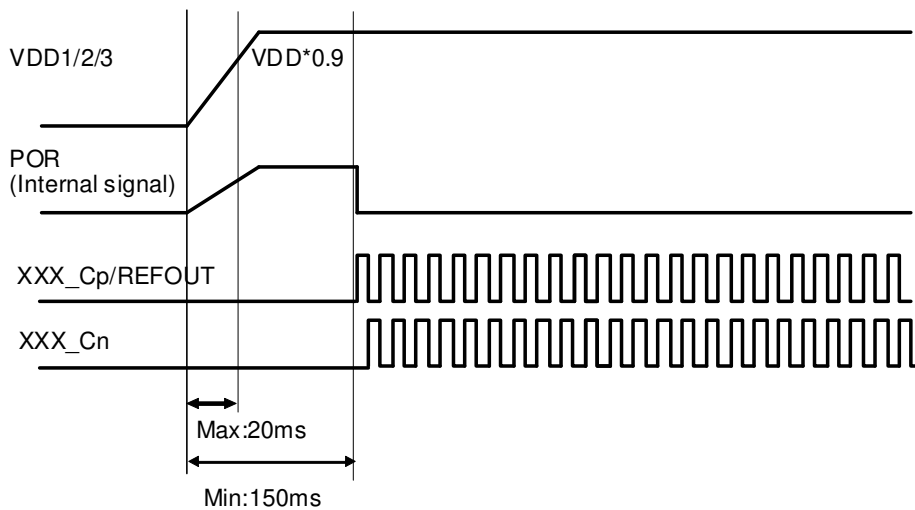

Figure.4 Recommend Power On Reset Sequence

Power down Control

When the PDCLKN is “L”, CPU_Cp/Cn, USB_Cp/Cn and SATA_Cp/Cn clocks are forced to “L”. When it is “H”, they are activated.

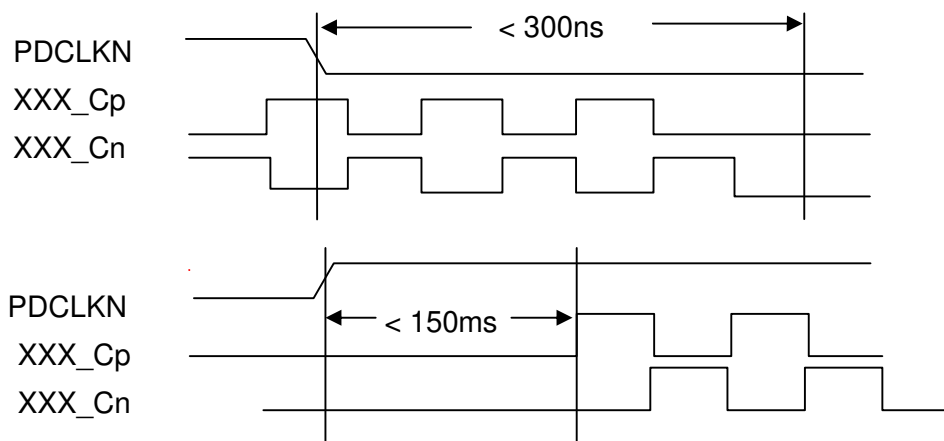

Figure.5 Power Down Sequence

Output clock frequency selection

The AK8137A generates a range of low-jitter and hi-accuracy clock frequencies with three built-in PLLs and provides four assigned outputs. A frequency selection at assigned output pin is configured by pin-setting of FSA and FSB.

The selectable frequency is shown in **Table 1**..

Table 1: Clock output Frequency

FSB	FSA	CPU_C Frequency (MHz)
L	L	100
L	H	133
H	L	166
H	H	200

Package Information

• 20SSOP Mechanical data

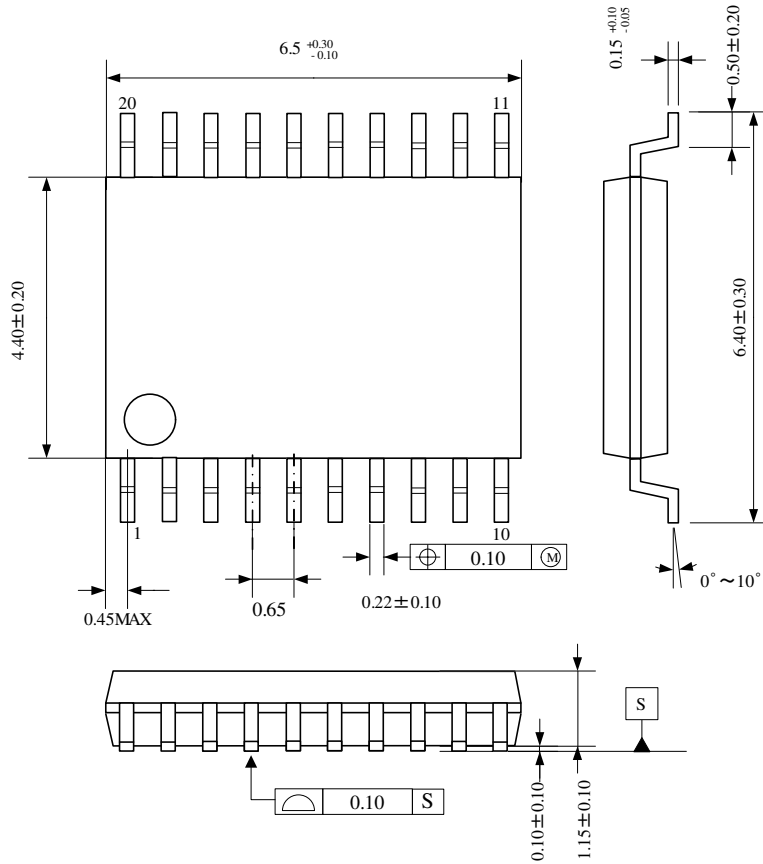

• Marking

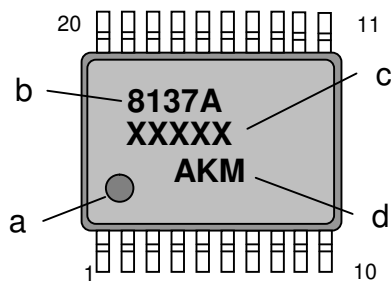

- a: #1 Pin Index
- b: Part number
- c: Date code (5 digits)
- d: Product Family Logo ⁽¹⁾

• RoHS Compliance



All integrated circuits from Asahi Kasei Microdevices Corporation (AKM) assembled in “lead-free” packages* are fully compliant with RoHS.

(* RoHS compliant products from AKM are identified with “Pb free” letter indication on product label posted on the anti-shield bag and boxes.

IMPORTANT NOTICE

- I These products and their specifications are subject to change without notice.
When you consider any use or application of these products, please make inquiries the sales office of Asahi Kasei Microdevices Corporation (AKM) or authorized distributors as to current status of the products.
- I AKM assumes no liability for infringement of any patent, intellectual property, or other rights in the application or use of any information contained herein.
- I Any export of these products, or devices or systems containing them, may require an export license or other official approval under the law and regulations of the country of export pertaining to customs and tariffs, currency exchange, or strategic materials.
- I AKM products are neither intended nor authorized for use as critical components^{Note1)} in any safety, life support, or other hazard related device or system^{Note2)}, and AKM assumes no responsibility for such use, except for the use approved with the express written consent by Representative Director of AKM. As used here:
 - Note1) A critical component is one whose failure to function or perform may reasonably be expected to result, whether directly or indirectly, in the loss of the safety or effectiveness of the device or system containing it, and which must therefore meet very high standards of performance and reliability.
 - Note2) A hazard related device or system is one designed or intended for life support or maintenance of safety or for applications in medicine, aerospace, nuclear energy, or other fields, in which its failure to function or perform may reasonably be expected to result in loss of life or in significant injury or damage to person or property.
- I It is the responsibility of the buyer or distributor of AKM products, who distributes, disposes of, or otherwise places the product with a third party, to notify such third party in advance of the above content and conditions, and the buyer or distributor agrees to assume any and all responsibility and liability for and hold AKM harmless from any and all claims arising from the use of said product in the absence of such notification.

Asahi Kasei EMD Corporation has changed its company name to Asahi Kasei Microdevices Corporation (AKM) effective 1st April 2009.

It is noted the documents according to this product, which was released before the date of 1st April 2009, shall include the old company name as Asahi Kasei EMD Corporation (AKEMD). These documents will be continuously valid by interpreting the old company name to the new one as Asahi Kasei Microdevices Corporation (AKM).

Further information of this company name change, contact AKM's sales person or AKM's authorized distributor.