

This document is the property of Amphenol Corporation and is delivered on the express condition that is not to be disclosed, reproduced or used, in whole or in part, for manufacture or sale by anyone other than Amphenol Corporation without its prior consent, and that no right is granted to disclose or to use any information in this document.

The marking on this product doesn't contain environmental hazardous materials per Material Specification 55-00259 for Sony GP compliant or per directive 2011/65/EU for RoHS compliant.



ORIGINAL

REVISIONS				
SYM	ECN No.	DESCRIPTION	DATE	APPROVED
A		RELEASE TO PRODUCTION	11/06/2008	Hank Hsu
B	NE-10180	MODIFIED DRAWING	11/04/2010	Arron Lin
C	NE-14038	CHANGE P/N FOR ADD T&R PACKING	03/18/2014	Arron Lin
D	NE-16300	ADD D/C AND 0.7mm DIM & UPDATE COVER PBT TO HTN	02/24/2017	Arron Lin
E	NE-17121	REMOVOR THE SHELL BOTTOM SPRING TO MEET CURRENT	06/01/2017	Arron Lin

NOTES:

- HOUSING: PBT, UL94V-0, COLOR- WHITE OR BLACK OR BLUE
- BOTTOM COVER: HTN, UL94V-0, COLOR- WHITE OR BLACK OR BLUE
- CONTACT: PHOSPHOR BRONZE, 0.25 MM THICKNESS SELECTIVE GOLD PLATED ON CONTACT AREA, 100μ" MIN. TIN PLATED ON SOLDERING AREA, 50μ" MIN. NICKEL UNDER-PLATING OVERALL
- SHELL: BRASS, 0.3 MM THICKNESS, 50μ" MIN. NICKEL PLATED OVERALL
- REAR SHELL: SPCC, 0.3 MM THICKNESS, 50μ" MIN. NICKEL PLATED OVERALL
- FOR WAVE SOLDERING PROCESS ONLY.
- PRODUCT SPECIFICATION REFER TO : PS-7329
- THIS PRODUCT DOESN'T CONTAIN ENVIRONMENTAL HAZARDOUS MATERIALS PER DIRECTIVE 2011/65/EU FOR RoHS.



P/N: GSB 191 X X X KEU

CONTACT FINISH
 1: GOLD FLASH
 2: 30μ" GOLD
 5: 15μ" GOLD

PACKING
 BLANK : TRAY
 R : T&R

COLOR OF INSULATOR
 0: WHITE
 1: BLACK
 3: BLUE (PANTONE 285C)

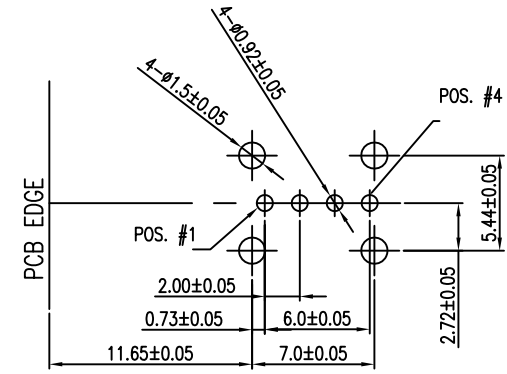
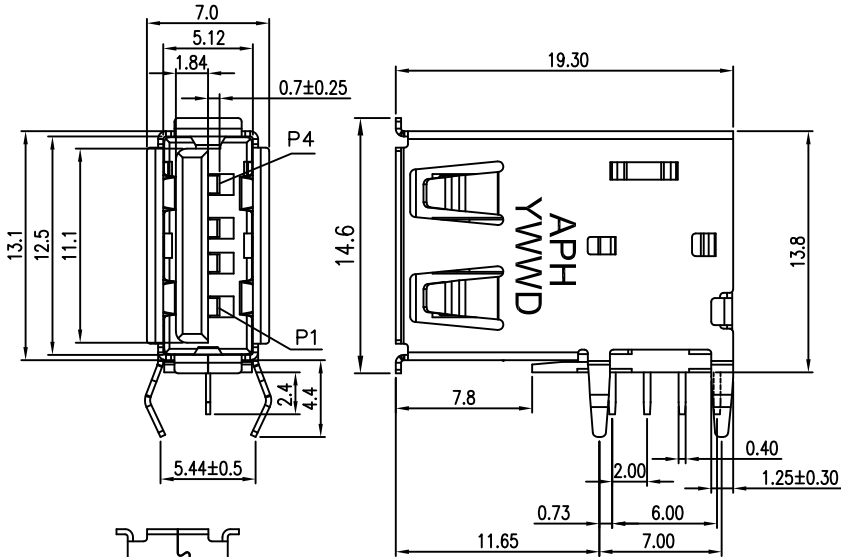

RECOMMENDED PC BOARD LAYOUT

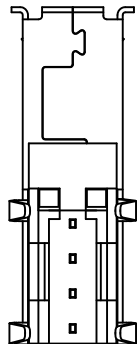

TOLERANCE	APPROVALS	DATE	TITLE		Amphenol®	
X. ±0.30	DRAWN Debby Hung	06/01/2017	UNIVERSAL SERIAL BUS RECEPTACLE, SERIES A UPRIGHT PCB MOUNT		Amphenol Corporation Amphenol Taiwan Corporation	
X.X ±0.20	CHECKED Sandy Wu	06/01/2017				
X.XXX ±0.10	APPROVED Arron Lin	06/01/2017				
ANGULAR ±1°	DWG TYPE CUST DWG	PROJECT CODE OTHER	UNIT mm	SIZE A3	PART No.	GSB191XXXKEU
UNLESS OTHERWISE SPECIFIED			SCALE NA	SHEET 1 OF 3	DWG No.	GSB191XXXKEU
					REV.	E

This document is the property of Amphenol Corporation and is delivered on the express condition that is not to be disclosed, reproduced or used, in whole or in part, for manufacture or sale by anyone other than Amphenol Corporation without its prior consent, and that no right is granted to disclose or to use any information in this document.
 The marking on this product doesn't contain environmental hazardous materials per Material Specification 55-00259 for Sony GP compliant or per directive 2011/65/EU for RoHS compliant.



ORIGINAL

REVISIONS				
SYM	ECN No.	DESCRIPTION	DATE	APPROVED
A		RELEASE TO PRODUCTION	11/06/2008	Hank Hsu
B	NE-10180	MODIFIED DRAWING	11/04/2010	Arron Lin
C	NE-14038	CHANGE P/N FOR ADD T&R PACKING	03/18/2014	Arron Lin
D	NE-16300	ADD D/C AND 0.7mm DIM & UPDATE COVER PBT TO HTN	02/24/2017	Arron Lin
E	NE-17121	REMOVOR THE SHELL BOTTOM SPRING TO MEET CURRENT	06/01/2017	Arron Lin

26 PCS TRAY/CARTON

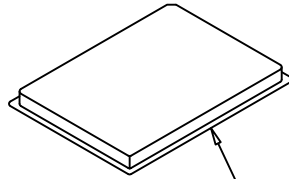
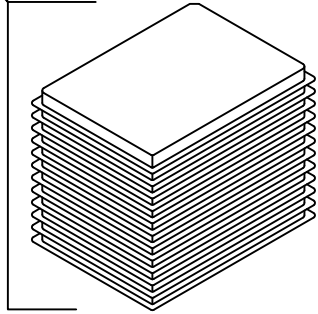

80 PCS/TARY

TRAY SIZE: 232 X 220 X 10

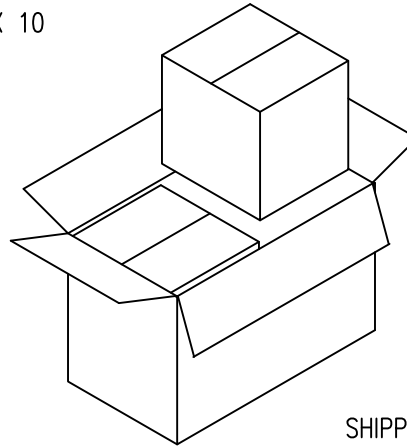
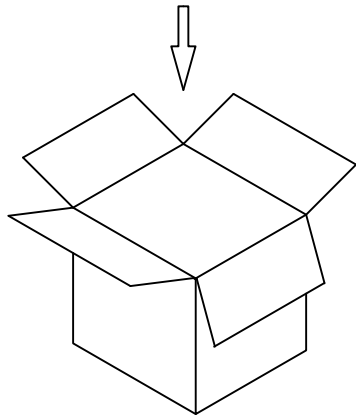

LABEL

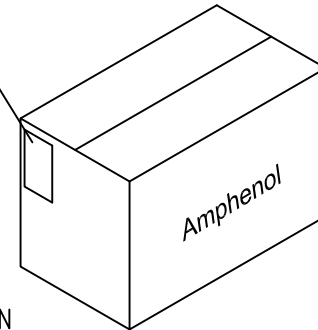

SHIPPING CARTON DIMENSION
520 X 273 X 310 MM

PART NUMBER	G/W <KG>	N/W <KG>	PARTS PER CARTON<S.P.Q>	PARTS PER TRAY	TOTEL TYAAS PER CARTON
GSB191XXKEU	15.2	10.8	4160	80	52

TOLERANCE	APPROVALS	DATE	TITLE		PART No.	
X. ±0.30	DRAWN Debby Hung	06/01/2017	UNIVERSAL SERIAL BUS RECEPTACLE, SERIES A UPRIGHT PCB MOUNT		Amphenol® Amphenol Corporation Amphenol Taiwan Corporation	
X.X ±0.20	CHECKED Sandy Wu	06/01/2017				
X.XXX ±0.10	APPROVED Arron Lin	06/01/2017				
ANGULAR ±1°	DWG TYPE CUST DWG	PROJECT CODE OTHER	UNIT mm	SIZE A3	PART No. GSB191XXXKEU	
UNLESS OTHERWISE SPECIFIED			SCALE NA	SHEET 2 OF 3	DWG No. GSB191XXXKEU	REV. E

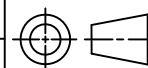

This document is the property of Amphenol Corporation and is delivered on the express condition that it is not to be disclosed, reproduced or used, in whole or in part, for manufacture or sale by anyone other than Amphenol Corporation without its prior consent, and that no right is granted to disclose or to use any information in this document.

The marking on this product doesn't contain environmental hazardous materials per Material Specification 55-00259 for Sony GP compliant or per directive 2011/65/EU for RoHS compliant.



ORIGINAL

REVISIONS				
SYM	ECN No.	DESCRIPTION	DATE	APPROVED
A		RELEASE TO PRODUCTION	11/06/2008	Hank Hsu
B	NE-10180	MODIFIED DRAWING	11/04/2010	Arron Lin
C	NE-14038	CHANGE P/N FOR ADD T&R PACKING	03/18/2014	Arron Lin
D	NE-16300	ADD D/C AND 0.7mm DIM & UPDATE COVER PBT TO HTN	02/24/2017	Arron Lin
E	NE-17121	REMOVOR THE SHELL BOTTOM SPRING TO MEET CURRENT	06/01/2017	Arron Lin

NOTES:

1. STAPLES SHOULD ONLY BE USED TO SET UP CARTON. ALL CARTON CLOSURES MUST BE DONE WITH TAPE.
2. FILL PACKAGING TRAYS WITH THE QUANTITIES AS INDICATED IN THE CHART.
3. SHIPPING CARTON DIMENSION: 690 X 360 X 325 MM.

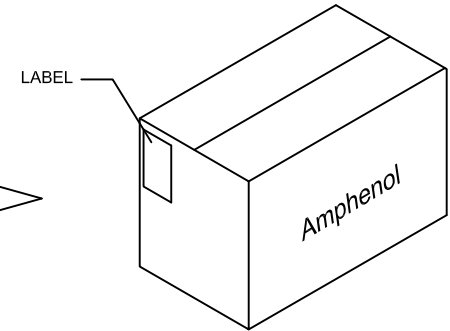
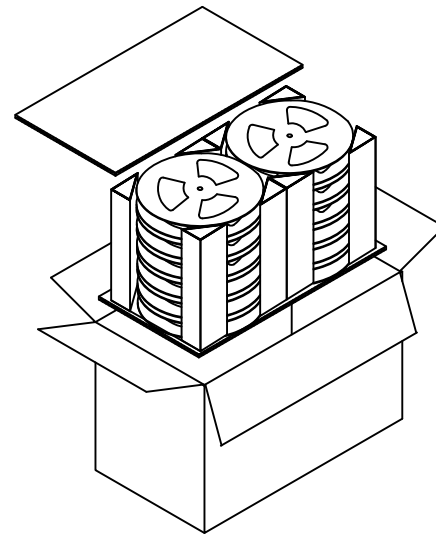
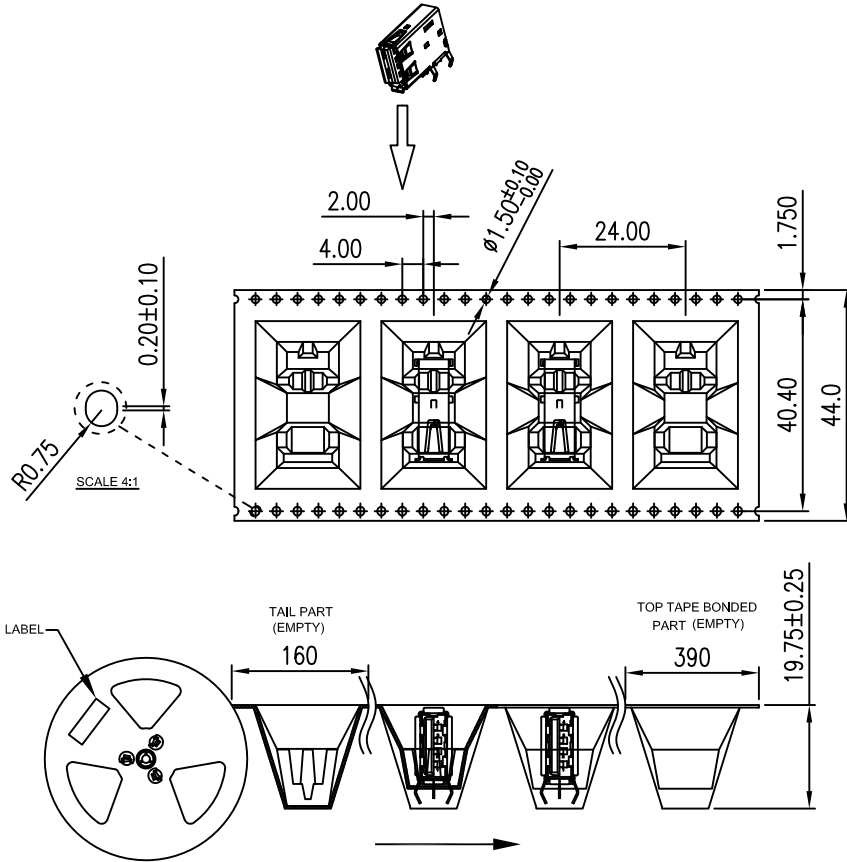

PART NUMBER	G/W <KG>	N/W <KG>	PARTS PER CARTON <S.P.Q>	PARTS PER REELS	TOTEL REELS PER CARTON
GSB191XXRKEU	10.7	3.7	1440	120	12

TOLERANCE	APPROVALS	DATE	TITLE	UNIVERSAL SERIAL BUS RECEPTACLE, SERIES A UPRIGHT PCB MOUNT		Amphenol® Amphenol Corporation Amphenol Taiwan Corporation	
X. ±0.30	DRAWN Debby Hung	06/01/2017		UNIT mm	SIZE A3	PART No.	GSB191XXXKEU
X.X ±0.20	CHECKED Sandy Wu	06/01/2017		SCALE NA	SHEET 3 OF 3	DWG No.	GSB191XXXKEU
X.XXX ±0.10	APPROVED Arron Lin	06/01/2017		REV. E			
ANGULAR ±1°	DWG TYPE CUST DWG	PROJECT CODE OTHER					
UNLESS OTHERWISE SPECIFIED							