

AL9910EV5 BUCK LED DRIVER USER GUIDE

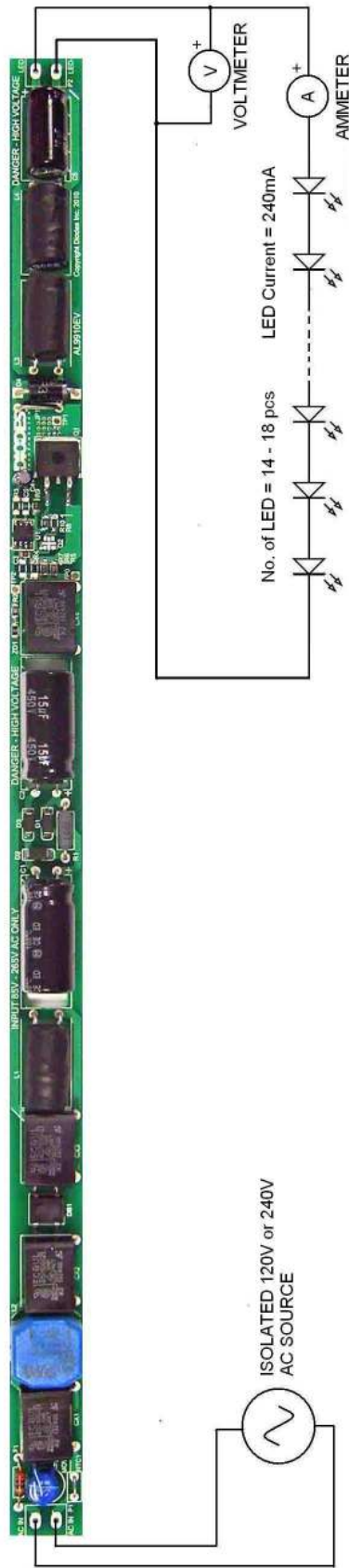

Fig. 1 AL9910EV5 evaluation board connection diagram

DESCRIPTION

The AL9910EV5 is an offline non-isolated LED driver Evaluation board designed to work on both 115V and 230V AC line voltages. It provides a constant LED current output which drives a single string of between 14 and 18 LEDs, with a LED current of 240mA.

The evaluation board is designed with a footprint to fit inside a T8 LED fluorescent replacement lamp tube. It will provide a total LED power ranging from 10W to 13W.

AL9910EV5 SETUP AND TESTING PROCEDURE

Prerequisite

1. AL9910EV5 evaluation board.
2. A set of 240mA LEDs strings with 14 to 18 series-connected LEDs. The LEDs should be mounted on a heatsink capable of a power dissipation of 10 to 13W.
3. For safety reasons during testing, please use an isolated 115V or 230V AC source from the output of an isolation transformer. For public demonstration, the evaluation board and LEDs should be fitted into a transparent case with sufficient insulation to meet the local safety requirements.

Connections and Power up

1. Preset the isolated AC source to either 115VAC or 230VAC.
2. **ENSURE THAT THE AC SOURCE IS SWITCHED OFF OR DISCONNECTED.**
3. Connect the anode wire of the LED string to the LED+ terminal which is located at the right hand side of evaluation board.
4. Connect the cathode wire of the LED string to the LED - terminal which is located at the right hand side of the evaluation board.
5. Connect a voltmeter & ammeter according to the connection diagram in Figure 1 if LED current and voltage measurements are required.
6. Connect the two AC line wires to the AC1 and AC2 terminals which are located at the left hand side of evaluation board.
7. Ensure that the area around the board is clear and safe, and preferably that the board and LEDs are enclosed in a transparent safety cover.
8. Turn on the mains switch. LED string should light up with LED current of 240mA +/-15%. **DO NOT TOUCH THE BOARD, LEDs OR BARE WIRING.**

Caution: The AL9910EV5 is a non-isolated design. All terminals carry high voltage during operation!

OPERATION

The AL9910A device is a PWM high-efficiency LED driver control IC. It allows efficient operation of High Brightness (HB) LEDs from voltage sources ranging from 85VAC up to 265VAC. The AL9910A can be configured to work in either fixed frequency or constant OFF-time mode. In fixed frequency mode, the AL9910A controls an external MOSFET at a fixed switching frequency up to 300kHz, which can be programmed using a single resistor. The LED string is driven at a constant current rather than at a constant voltage, thus providing constant light output and enhanced reliability. The output current can be programmed between a few milliamps and more than 1.0A.

Input filter and Rectifier section

In order to meet the EMI requirement, Cx1, Cx2, CX3, CX4, L1 and L2 are used to provide sufficient filtering for both differential-mode and common-mode noise generated from the switching converter circuit after the bridge rectifier.

The rectified line voltage from the bridge rectifier DB1 is fed into a valley-filled passive power factor correction stage to provide a high power factor for the AC line input. The passive PFC stage comprises of C11, C2, D1, D2, D3 and R1. This design gives power factors of greater than 0.9 at low line voltage.

Constant Current Buck Converter section

The buck converter section consists of LED controller AL9910A (U1), Ultra-fast free-wheeling rectifier SF30JG (D4), Inductor (L3 and L4) and a high voltage MOSFET switch (Q1). On this evaluation board, the AL9910A is configured to operate in the constant OFF-time mode to provide the best LED current regulation. The constant OFF-time of the AL9910A's gate output is set to approximately 14 μ s using resistor R9. Please refer to the product datasheet for more details on how to configure the constant OFF-time mode.

The circuit values have been designed to provide an output current of 240mA. The LED current level is set by resistors R5-R7. For detailed applications information please refer to the AL9910/A datasheet.

There is also provision for an optional gate transistor pair (Q2) to drive a MOSFET with a higher gate charge if a higher LED current is required. Q2 is a high current gate driver in a SOT23-6 package.

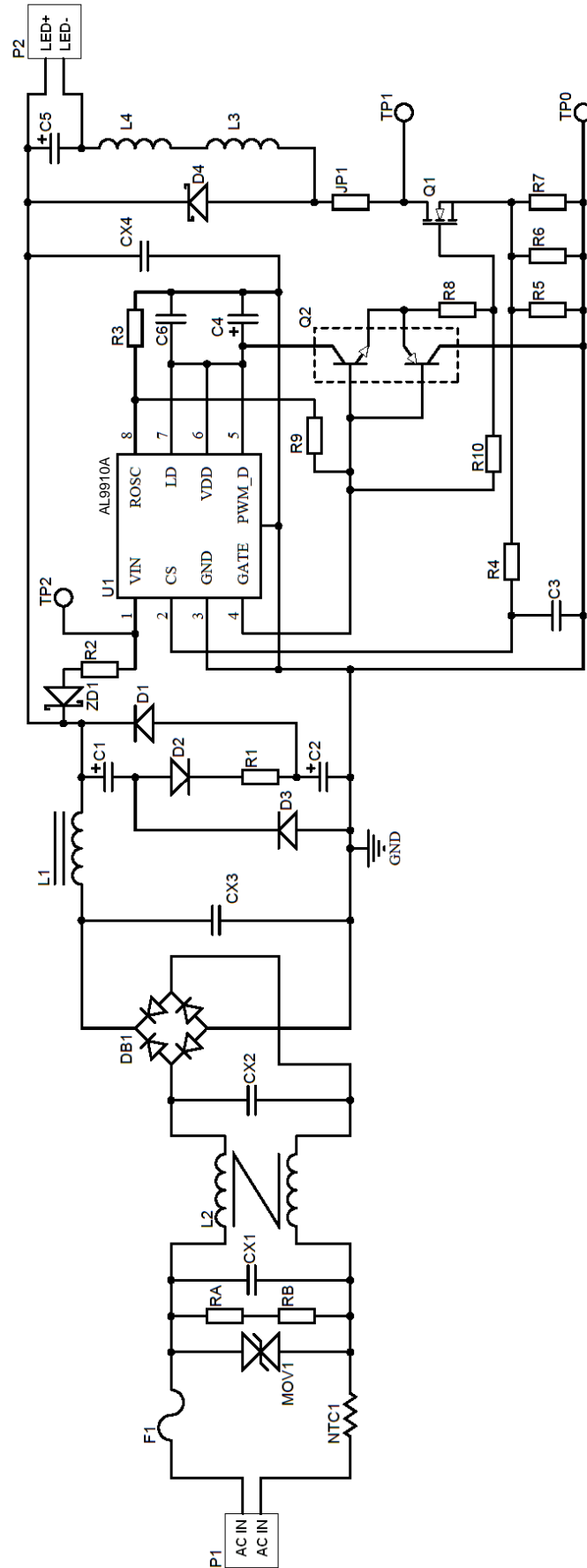
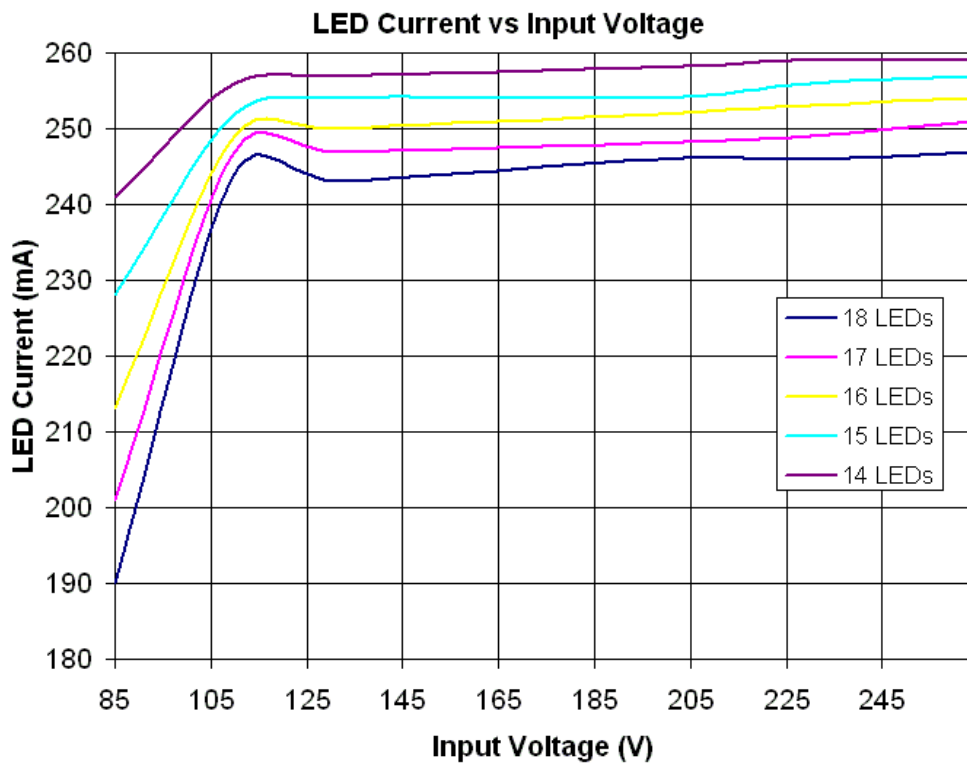
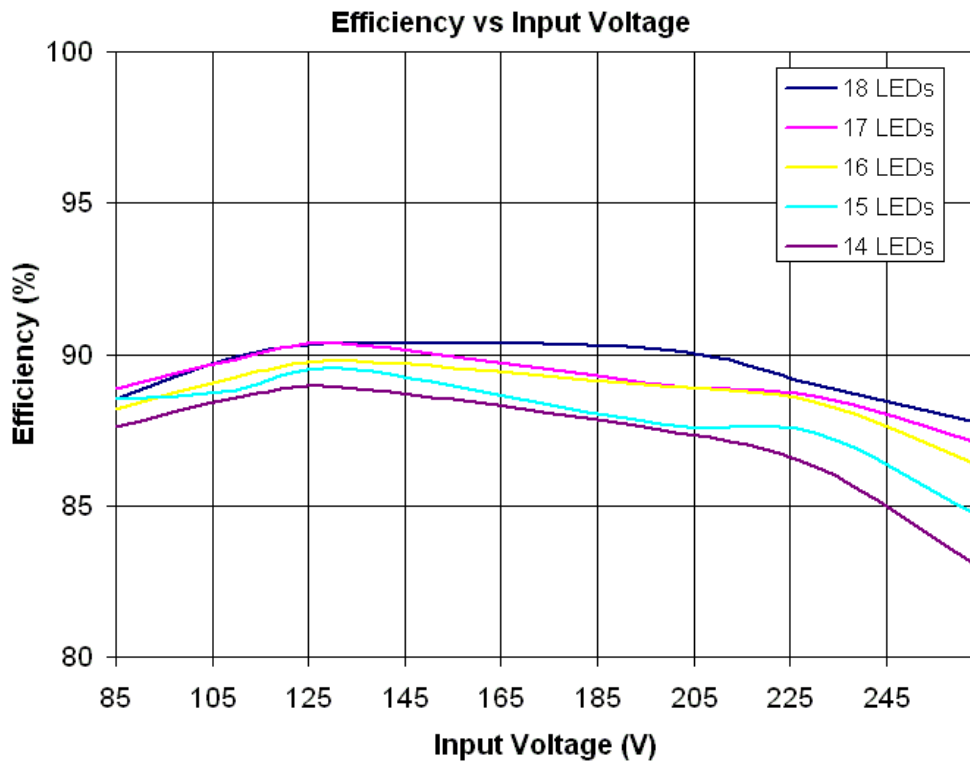

Fig. 2 AL9910EV5 Schematic Diagram

PARTS LIST

Ref	Description	P/N	Package	Manufacturer
U1	Universal high brightness LED driver	AL9910A	SO8	Diodes Inc
D1 D2 D3	1A 1KV diode $t_{RR}=1.8\mu s$	S1M-13-F	SMA	Diodes Inc
D4	Ultra-fast-recovery diode 3A 600V $t_{RR}=50ns$	SF30JG-B	DO201AD	Diodes Inc
DB1	1A, 600V bridge rectifier	DF06S	DF-S	Diodes Inc
C1 C2	15 μ F 450V electrolytic capacitor +/-20% 1000hrs @ 105C	EEUED2W150 400KXW27M10X30 UCY2G150MPD	5mm pitch	Panasonic Rubycon Nichicon
C3 C6	OMIT		1206	
C4	4.7 μ F 50V electrolytic capacitor +/-20% 1000hrs @ 105C	ECE-A1HKG4R7	1.5mm pitch	Panasonic
C5	10 μ F 450V electrolytic capacitor +/-20% 1000hrs @ 105C, 10mm diameter	EEUEE2W100U	5mm pitch	Panasonic
CX1 CX2 CX3 CX4	100nF, 275VAC, Film, X2	ECQU2A104ML	15mm pitch	Panasonic
F1	100 Ω 1W fusible resistor +/-200ppm	NFR0100001009JR500	Through-hole axial	Vishay
JP1	Link with 22 to 26 SWG tinned copper wire			
L1	6.8mH inductor +/-10% 290mA radial	19R685C	6mm pitch	Murata
L2	22mH or 30mH common mode inductor, 8mm height	B82791G2351N001 B82791G2301N001		EPCOS EPCOS
L3 L4	3.3mH inductor +/-10% 420mA radial	19R335C	6mm pitch	Murata
MOV1	275V, 21J, 9mm, Radial	B72207S0271K101	5mm pitch	EPCOS
NTC1	Wire link			
Q1	N-ch 600V MOSFET 3.2A, $Q_{g(max)}=16nC$	SPB03N60S5	TO263	Infineon
Q2	NOT FITTED		SOT23-6	
R1	10R 3W wirewound resistor, +/-50ppm/C, +/-1%	UB3C-10RF1	Through-hole axial	Riedon
R2	3K 0.25W resistor +/-5%	Any	1206	Any
R4	0R 0.125W resistor +/-5%	Any	0805	Any
R5	1R2 0.25W +/-1%	Any	1206	Any
R6	2R7 0.25W +/-1%	Any	1206	Any
R7	100R 0.25W +/-1%	Any	1206	Any
R3 R8 RA RB	NOT FITTED		1206	
R9	330K 0.25W resistor +/-1%	Any	1206	Any
R10	10R 0.25W +/-5%	Any	1206	Any
ZD1	0R 0.25W +/-5%	Any	1206	Any

PERFORMANCE



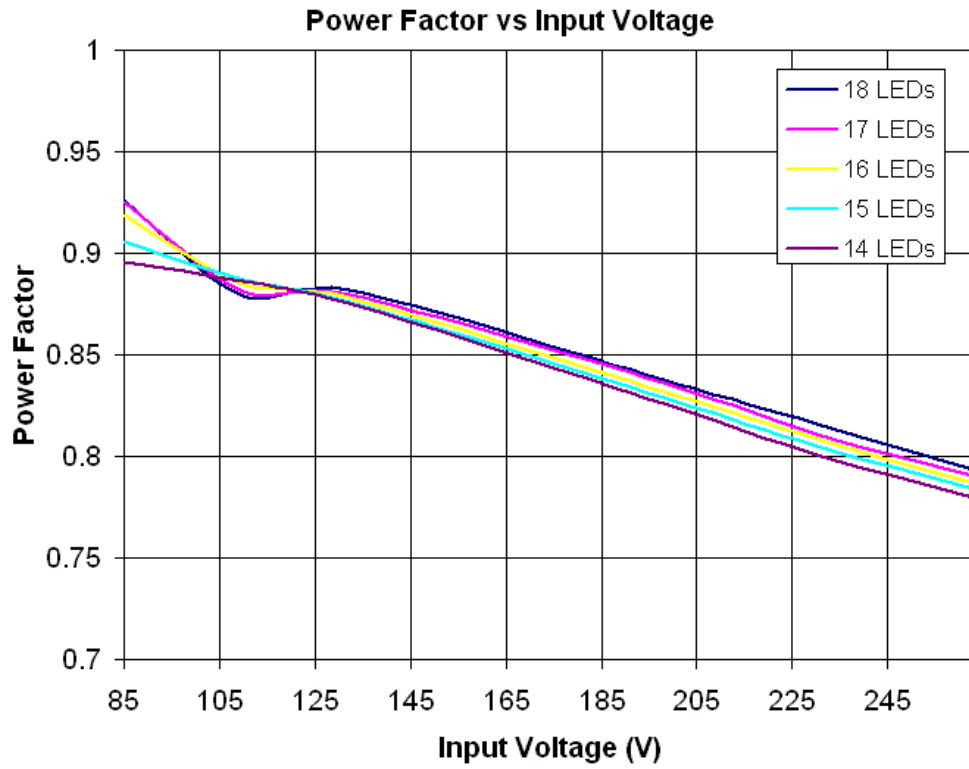

IMPORTANT NOTICE

DIODES INCORPORATED MAKES NO WARRANTY OF ANY KIND, EXPRESS OR IMPLIED, WITH REGARD TO THIS DOCUMENT, INCLUDING, BUT NOT LIMITED TO, THE IMPLIED WARRANTIES OF MERCHANTABILITY AND FITNESS FOR A PARTICULAR PURPOSE (AND THEIR EQUIVALENTS UNDER THE LAWS OF ANY JURISDICTION).

Diodes Incorporated and its subsidiaries reserve the right to make modifications, enhancements, improvements, corrections or other changes without further notice to this document and any product described herein. Diodes Incorporated does not assume any liability arising out of the application or use of this document or any product described herein; neither does Diodes Incorporated convey any license under its patent or trademark rights, nor the rights of others. Any Customer or user of this document or products described herein in such applications shall assume all risks of such use and will agree to hold Diodes Incorporated and all the companies whose products are represented on Diodes Incorporated website, harmless against all damages.

Diodes Incorporated does not warrant or accept any liability whatsoever in respect of any products purchased through unauthorized sales channels. Should Customers purchase or use Diodes Incorporated products for any unintended or unauthorized application, Customers shall indemnify and hold Diodes Incorporated and its representatives harmless against all claims, damages, expenses, and attorney fees arising out of, directly or indirectly, any claim of personal injury or death associated with such unintended or unauthorized application.

Products described herein may be covered by one or more United States, international or foreign patents pending. Product names and markings noted herein may also be covered by one or more United States, international or foreign trademarks.

LIFE SUPPORT

Diodes Incorporated products are specifically not authorized for use as critical components in life support devices or systems without the express written approval of the Chief Executive Officer of Diodes Incorporated. As used herein:

A. Life support devices or systems are devices or systems which:

1. are intended to implant into the body, or
2. support or sustain life and whose failure to perform when properly used in accordance with instructions for use provided in the labeling can be reasonably expected to result in significant injury to the user.

B. A critical component is any component in a life support device or system whose failure to perform can be reasonably be expected to cause the failure of the life support device or to affect its safety or effectiveness.

Customers represent that they have all necessary expertise in the safety and regulatory ramifications of their life support devices or systems, and acknowledge and agree that they are solely responsible for all legal, regulatory and safety-related requirements concerning their products and any use of Diodes Incorporated products in such safety-critical, life support devices or systems, notwithstanding any devices- or systems-related information or support that may be provided by Diodes Incorporated. Further, Customers must fully indemnify Diodes Incorporated and its representatives against any damages arising out of the use of Diodes Incorporated products in such safety-critical, life support devices or systems.

Copyright © 2009, Diodes Incorporated

www.diodes.com

Sales offices**The Americas**

3050 E. Hillcrest Drive
Westlake Village,
CA 91362-3154
Tel: (+1) 805 446 4800
Fax: (+1) 805 446 4850

Europe

Kustermannpark
Balanstraße 59,
D-81541 München
Germany
Tel: (+49) 894 549 490
Fax: (+49) 894 549 4949

Taiwan

7F, No. 50,
Min Chuan Road
Hsin-Tien
Taipei, Taiwan
Tel: (+886) 289 146 000
Fax: (+886) 289 146 639

Shanghai

Rm. 606, No.1158
Changning Road
Shanghai, China
Tel: (+86) 215 241 4882
Fax (+86) 215 241 4891

Shenzhen

Room A1103-04,
ANLIAN Plaza, #4018
Jintian Road
Futian CBD,
Shenzhen, China
Tel: (+86) 755 882 849 88
Fax: (+86) 755 882 849 99

Korea

6 Floor, Changhwa B/D,
1005-5 Yeongtong-dong,
Yeongtong-gu, Suwon-si,
Gyeonggi-do, Korea 443-813
Tel: (+82) 312 731 884
Fax: (+82) 312 731 885