

Description

The ZWIR4532 is a programmable low-power secure IPv6 communication module for internet of things (IOT) device networks. Sensors and devices can operate autonomously or connect to local or global IPv6 networks using the ZWIR4532. The ZWIR4532 serves as a universal secure radio communication module for applications with low bandwidth requirements.

The module incorporates an ultra-low-power ARM® Cortex™-M0+ 32-bit microcontroller which is running the network stack. In addition, the user application can run on the microcontroller. This helps minimizing the size, complexity and overall BOM. A rich set of digital and analog peripherals is available for interfacing with external application components. Approximately 128kB of flash and 4kB of RAM are available for user applications.

IDT offers the SensorShare user programmable royalty-free 6LoWPAN network stack with mesh routing capability for the ZWIR4532. 6LoWPAN is an Internet Engineering Task Force (IETF) standard for wireless low-power IPv6-based sensor and device networks.

Secure communication is provided by a standard-compliant implementation of the Internet Protocol Security (IPSec) protocol suite.

Typical Applications

- Industrial automation
- Home and building automation
- Health monitoring
- Telemetry

Block Diagram

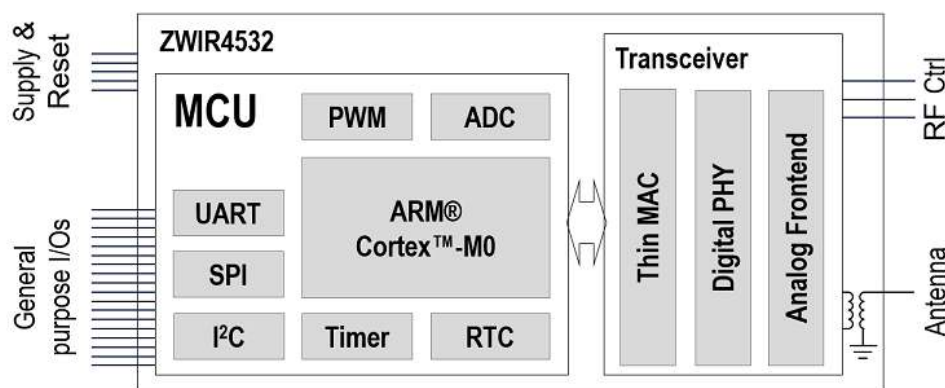

Features

- License-free 868/915 MHz frequency bands
 - 4 channels in EU frequency band (865.3 – 868.3 MHz)
 - 10 channels in US frequency band (906 – 924 MHz)
 - BPSK or O-QPSK modulation selectable
 - BPSK with 20kBps EU and 40kBps U
- ARM® Cortex™-M0+ 32-bit ultra-low-power microcontroller
 - 192kB flash and 20kB RAM
 - 6kByte EEPROM
 - 5 UART interfaces
 - 1 SPI interface
 - 3 I²C interfaces
 - 10 PWM outputs
 - 12 bit ADC with 10 input channels
 - 2 analog comparators
 - 31 GPIOs
- Network Stack
 - UDP/IPv6 communication
 - Mesh networking with hundreds of nodes
 - Self-healing defective routes
 - Over-the-Air update capable
 - Network layer security
- Ultra-low power stop mode: < 1µA with full RAM retention
- Supply voltage: 1.8V to 3.3V
- -40°C to +85°C ambient operating temperature
- 15.6 × 12 mm 43-LGA Package