

RECOMMENDED PLATED THRU HOLE PATTERN  
SCALE 2:1

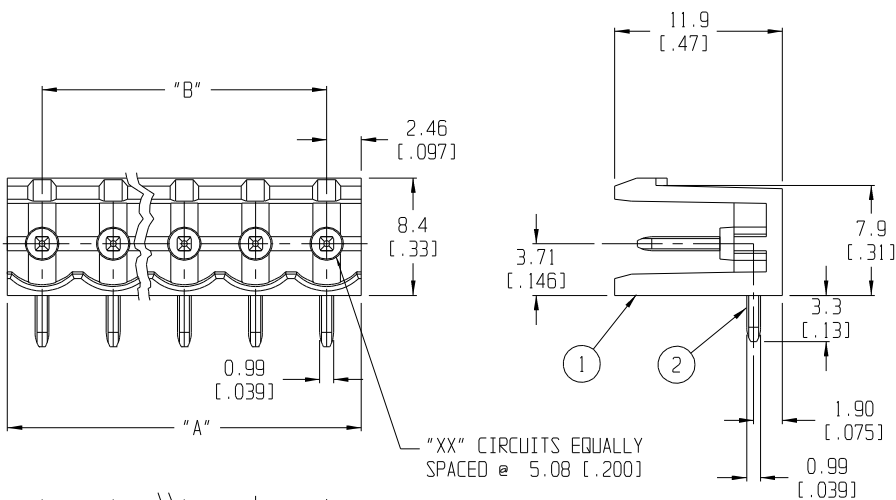

"XX" CIRCUITS EQUALLY SPACED @ 5.08 [0.200]

NOTES:

1. MATERIAL: SEE TABLE
2. FINISHES: SEE TABLE
3. PRODUCT SPECIFICATION: NOT REQUIRED
4. PACKAGING: NOT REQUIRED
5. MATES WITH: NONE
6. "XX" REFERS TO THE QUANTITY OF CIRCUIT POSITIONS.
7. REFER TO DWG SD-38120-003 FOR OPTIONAL IMPRINTING (-10A AND -11A)

NO. OF CIRC. "XX"	DIM. "A"	DIM. "B"	BLACK (STD.) MATERIAL NO.	BLACK MATERIAL NO. (-G30 OPT)	BLACK MATERIAL NO. (-10A OPT)	GREEN MATERIAL NO.
02	10.03 [0.395]	5.08 [0.200]	39860-0602	39861-0602	39862-0602	39860-3602
03	15.11 [0.595]	10.16 [0.400]	39860-0603	39861-0603	39862-0603	39860-3603
04	20.19 [0.795]	15.24 [0.600]	39860-0604	39861-0604	39862-0604	39860-3604
05	25.27 [0.995]	20.32 [0.800]	39860-0605	39861-0605	39862-0605	39860-3605
06	30.35 [1.195]	25.40 [1.000]	39860-0606	39861-0606	39862-0606	39860-3606
07	35.43 [1.395]	30.48 [1.200]	39860-0607	39861-0607	39862-0607	39860-3607
08	40.51 [1.595]	35.56 [1.400]	39860-0608	39861-0608	39862-0608	39860-3608
09	45.59 [1.795]	40.64 [1.600]	39860-0609	39861-0609	39862-0609	39860-3609
10	50.67 [1.995]	45.72 [1.800]	39860-0610	39861-0610	39862-0610	39860-3610
11	55.75 [2.195]	50.80 [2.000]	39860-0611	39861-0611	39862-0611	39860-3611
12	60.83 [2.395]	55.88 [2.200]	39860-0612	39861-0612	39862-0612	39860-3612
13	65.91 [2.595]	60.96 [2.400]	39860-0613	39861-0613	39862-0613	39860-3613
14	70.99 [2.795]	66.04 [2.600]	39860-0614	39861-0614	39862-0614	39860-3614
15	76.07 [2.995]	71.12 [2.800]	39860-0615	39861-0615	39862-0615	39860-3615
16	81.15 [3.195]	76.20 [3.000]	39860-0616	39861-0616	39862-0616	39860-3616
17	86.23 [3.395]	81.28 [3.200]	39860-0617	39861-0617	39862-0617	39860-3617
18	91.31 [3.595]	86.36 [3.400]	39860-0618	39861-0618	39862-0618	39860-3618
19	96.39 [3.795]	91.44 [3.600]	39860-0619	39861-0619	39862-0619	39860-3619
20	101.47 [3.995]	96.52 [3.800]	39860-0620	39861-0620	39862-0620	39860-3620
21	106.55 [4.195]	101.60 [4.000]	39860-0621	39861-0621	39862-0621	39860-3621
22	111.63 [4.395]	106.68 [4.200]	39860-0622	39861-0622	39862-0622	39860-3622
23	116.71 [4.595]	111.76 [4.400]	39860-0623	39861-0623	39862-0623	39860-3623
24	121.79 [4.795]	116.84 [4.600]	39860-0624	39861-0624	39862-0624	39860-3624

ITEM	QTY.	DESCRIPTION	MATERIAL	FINISH
2	XX	HEADER PIN (-G30 OPTION)	BRASS	GOLD PLATE
		HEADER PIN	BRASS	TIN PLATE
1	1	INSULATOR	NYLON	SEE CHART

EC NO. ECN 3656 DRWN: CY 05-05-04 CHK: APPR:	MAJOR CRITICAL SPC S	GENERAL TOLERANCES: (UNLESS SPECIFIED) mm      INCH		SCALE 3:1	DESIGN UNITS <input type="checkbox"/> mm <input checked="" type="checkbox"/> INCH	THIRD ANGLE PROJECTION	DIMENSIONS: <input checked="" type="checkbox"/> mm <input type="checkbox"/> INCH <input type="checkbox"/> mm ONLY	SHT    REV
		DRAWN BY & DATE R. KEMP    12-05-01	CHECKED BY & DATE P. WALTZ   12-06-01	APPROVED BY & DATE L. ROTHHAUS   12-06-01	CAD FILENAME 8618XX	MATERIAL NO. SEE CHART	DRAWING NO. SD-39860-010	SHEET NO. 1 OF 1
DRAFT WHERE APPLICABLE MUST REMAIN WITHIN DIMENSIONS		THIS DRAWING CONTAINS INFORMATION THAT IS PROPRIETARY TO MOLEX INCORPORATED AND SHOULD NOT BE USED WITHOUT WRITTEN PERMISSION.						SIZE B

HEADER RA, ASSEMBLY  
(5.08 [0.200] CENTERS)

MOLEX INCORPORATED