

Features

General

- Minimum number of inexpensive external components
- Auto shutdown in case of over temperature with internal or external temperature sensor
- Small package allows compact module design with minimised wire runs and short connections to achieve improved EMI performance
- MLX10801 is offered in 2 package options: SOIC8 and MLPD8 5x5. The MLPD8 5x5 package option allows to take out a higher peak and average current than the SOIC8 package option

LED driver

- High energy efficiency
- Light control via PWM possible
- Light output has a minimized dependency on supply and temperature variations
- Adjustable LED parameters are stored in an internal NV memory

Coil driver

- Additional use for driving coils like relays and micro valves in a power saving mode
- Works with a wide range of coils

Electronic fuse

- Additional use as electronic fuse.
- Fuse current adjust possibility

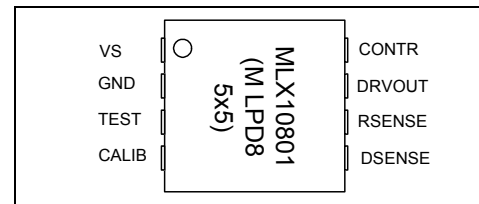
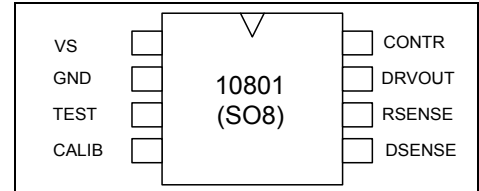

Ordering Information

Part Nr	Temperature Code	Package Code
MLX10801	R (-40°C to 105°C)	DC (SOIC8)
MLX10801	R (-40°C to 105°C)	LDC (MLPD8 5x5)

General Description

The MLX10801 is a multi-purpose LED driver for high power LEDs designed for automotive applications. A lot of adjustment possibilities allow for the design of different LED applications using only a few external components.

The circuit is load dump protected for a 40V load dump pulse.

As a second use, a variety of coils like relays and micro valves can be driven in a very efficient power saving mode.

A third use is a simple electronic fuse, to protect circuits from overcurrent or overtemperature.

Table of content

Features.....	1
Ordering Information.....	1
General Description.....	1
Table of content.....	2
Block diagram.....	4
1. Typical application data.....	5
1.1. LED driver applications.....	5
1.1.1. Complete schematic LED driver diagram.....	5
1.1.2. Minimum schematic LED driver diagram.....	5
1.1.3. LED driver application notes.....	6
1.1.3.1. LED driver application notes for MLX10801 in MLPD8 5x5.....	7
1.2. Coil driver applications.....	8
1.2.1. Coil driver schematic diagram.....	8
1.2.2. Coil driver application notes.....	8
1.3. Electronic fuse applications.....	9
1.3.1. Electronic fuse schematic diagram.....	9
1.3.2. Electronic fuse application notes.....	9
2. Application pins.....	10
3. Absolute maximum ratings.....	11
4. Electrical characteristics.....	13
5. EE-Latch characteristics.....	16
6. ESD/EMI recommendations for MLX10801.....	16
7. Automotive test pulses.....	17
7.1. Test pulse definition.....	18
8. LED driving principle.....	21
8.1. General.....	21
8.2. The principle in detail.....	22
8.3. Coil inductance, EMI and selected parameter set.....	23
8.4. Switching frequency considerations and constant light output.....	25
9. Coil driving principle.....	26
9.1. General.....	26
9.2. The principle in detail.....	26
10. Electronic fuse principle.....	26
11. Sleep mode.....	27
12. Temperature shutdown.....	27
13. Load dump protection.....	27
14. The calibration.....	27
14.1. The internal control register.....	27
14.2. The Influence of the pseudo random generator to the monoflop time.....	29
14.3. The calibration interface.....	30
14.4. The calibration procedure.....	31
14.4.1. Calibration procedure for LED driver applications.....	31
14.4.2. Calibration procedure for coil driver applications.....	32
14.4.3. Calibration procedure for electronic fuse applications.....	32
15. Data content of delivered parts.....	33
16. Mechanical Data.....	34
16.1. Mechanical data of the MLX10801 in SOIC8.....	34
16.2. Mechanical data of the MLX10801 in MLPD8 5x5.....	35
16.3. Melexis standard soldering information.....	38
17. History record.....	39

18. Disclaimer 41

Block diagram

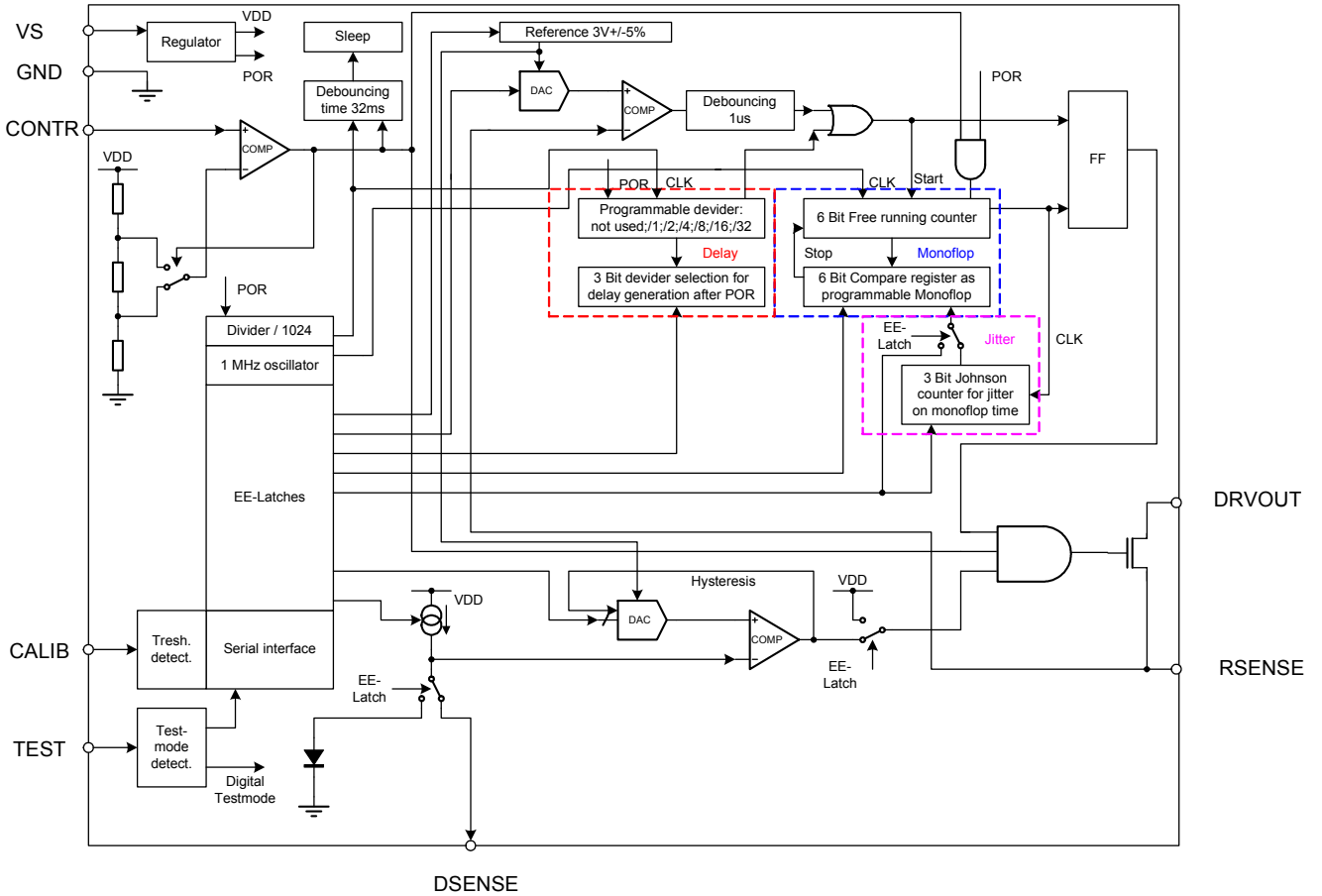

1. Typical application data

1.1. LED driver applications

1.1.1. Complete schematic LED driver diagram

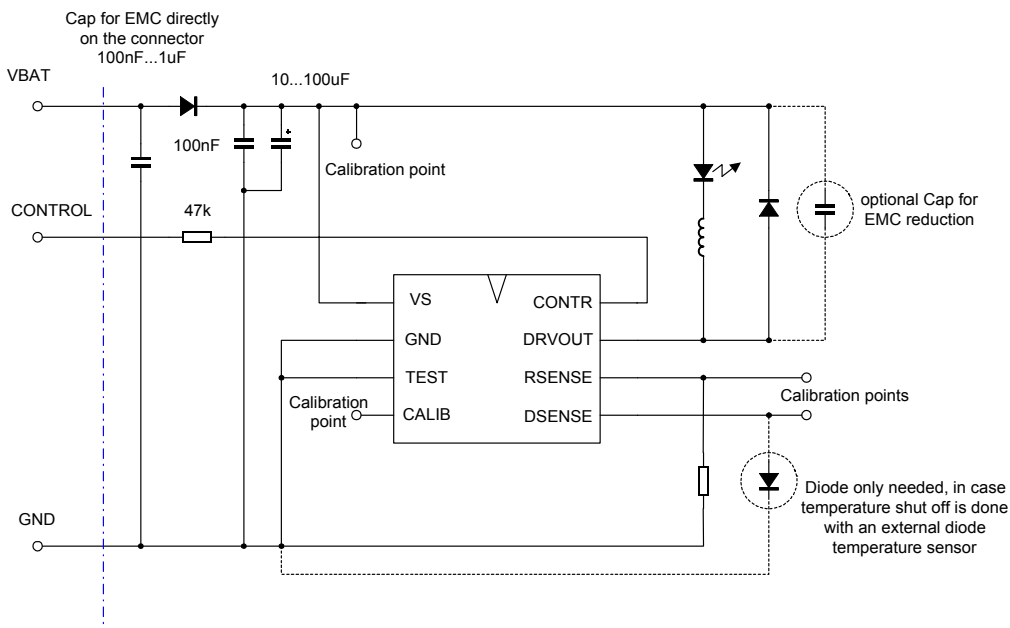

1.1.2. Minimum schematic LED driver diagram

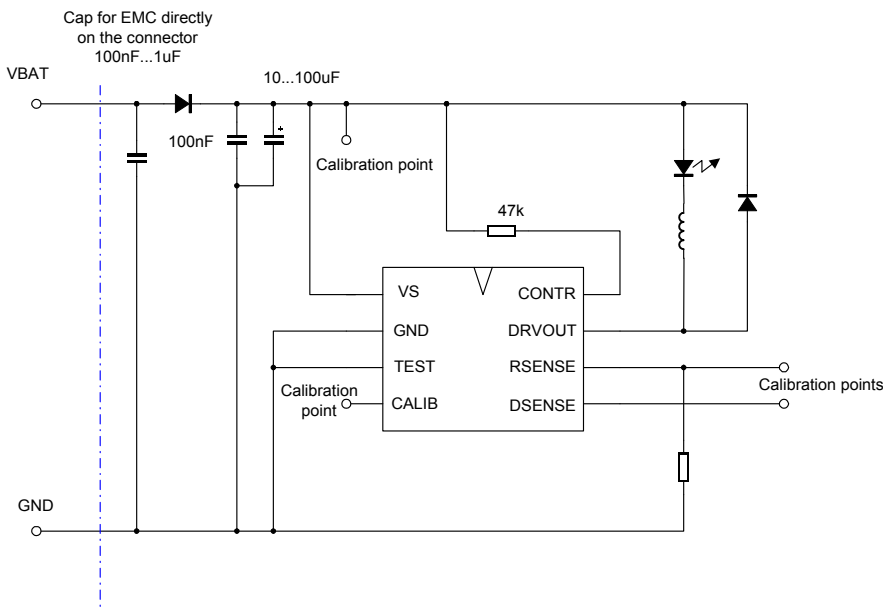

1.1.3. LED driver application notes

The MLX10801 is optimised for the use of low cost coils. For a standard application with 1 LED and an average current of 350mA a coil of about 100 μ H...470 μ H having $\leq 1R$ omic resistance should be chosen. The sense resistor should have a value between 0.47R...1R / 250mW.

As a general rule: the higher the load current, the lower the inductance of the coil should be, since higher currents lengthen the charging time of the coil. Switching frequencies lower than 20kHz are often not desired. It is possible (without manipulating the internal IC trimming data) to set the peak current and the average current of the LED by a variation of sense resistor and coil value. The same can be achieved by programming a modified parameter set to the EEPROM of the IC.

The free wheel diode that carries the load current during the passive state (driver OFF) should be a very fast switching diode like ES1D or BYG80 with a recommended $t_{rr} < 30ns$ in order to avoid parasitic spikes on RSENSE. The diode must be able to carry the current flowing in the LED.

For applications that use an external temperature sensor, virtually any low cost diode with a temperature coefficient of -2mV/K can be used.

In case of longer lines between the IC and the coil (which should be avoided because of EMI), a capacitor might be placed in parallel to RSENSE to avoid crosstalk and parasitic switching. A well chosen parameter set can help to avoid such a condition. The goal should be to unload the coil as much as possible during the selected monoflop time (see as well chapter 8.3).

The schematic diagram under 1.1.1 is used in applications, where the LED is controlled by external control electronics. A PWM with a frequency between 30Hz..4kHz can be applied to the CONTROL pin in order to dim the light output. This frequency is limited by the debouncing time for the sleep mode on the lower side and the selected monoflop time on the upper side of that range.

This function can be used to achieve different light outputs or also be used in a temperature down regulation.

It is recommended to have the PWM frequency at least 5-10 times lower than the selected driver switching frequency.

The minimum schematic diagram under 1.1.2 is sufficient for all applications with a constant light output. Nevertheless a dimming function could be achieved by a PWM driving directly on the module supply. In this mode, the PWM frequency should be chosen between 0 and 1kHz. It is limited by the maximum IC settling time.

1.1.3.1.LED driver application notes for MLX10801 in MLPD8 5x5

The MLX10801 assembled in a MLPD8 5x5 package allows to take out of the IC a higher average and a higher peak current.

The pre calibration data of the MLX10801 in all types of packages is identical.

In order to take advantage of the bigger output current capability without changing the ICs pre trimmed parameter set, the user can change the values of the coil and the sense resistor.
A typical LED average current of approx. 700mA can be achieved by using a coil of 220uH and a sense resistor of 0,3 Ohm.

In case of such typical high current applications, the user must provide a suitable heat sink possibility on the PCB.

Changing the pre calibrated data, which is stored in the internal EEPROM, allows to tune the IC also to other coil and sense resistor values, the EMC performance can be influenced as well.

Please check as well out the MLX10801 application notes for different driving solutions, which allow to drive more than one high power LED on a single MLX10801.

1.2. Coil driver applications

1.2.1. Coil driver schematic diagram

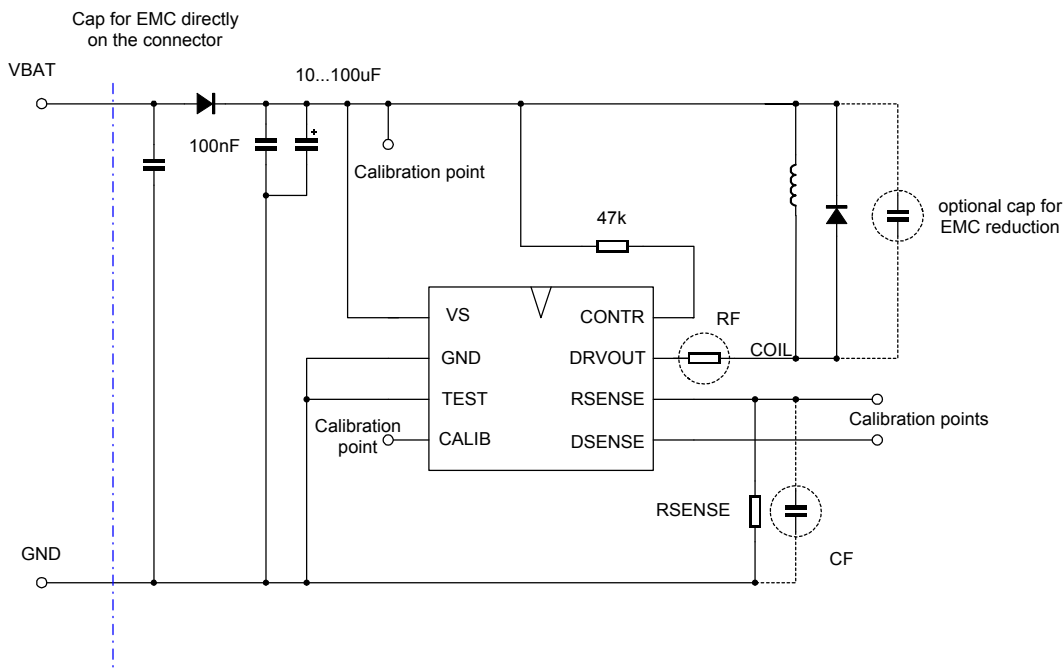

1.2.2. Coil driver application notes

The purpose of this application is to drive a coil in a power saving efficient way using a switched mode power supply. Coils of 10mH...5H can be driven. Attention has to be drawn to the maximum allowed current which must not be exceeded.

In case of high inductive coils and/or longer cables between the IC and the coil, CF and RF might be needed for reducing electromagnetic emissions.

When the driver switches on, the coil still contains a certain amount of energy, which is connected to a high voltage on node COIL. Via the R_{DSon} of the driver this voltage together with switching oscillations is then coupled to RSENSE. If these switching oscillations do not disappear within the debouncing time of the comparator (typically 1 μ s) the driver is switched off immediately, an effect known as "parasitic switching". A solution to that could be:

- CF, R_{DSon} + RF form a filter
- CF only acts in case the driver switches ON (in the OFF state it is quickly discharged by RSENSE)
- R_{DSon} + RF should be larger than RSENSE
- RSENSE and CF must be directly connected to pin RSENSE
- CF and RF must be figured out in the application. However, typical start values are RF=0 (not used) and CF=1.5uF.

The idea is to decouple the node COIL from RSENSE so that the switch off voltage can not be reached. Thus, parasitic switching is avoided.

Instead of using RF and CF, “parasitic switching” can also be avoided by a well chosen parameter set (see also chapter 8.3) and a well designed PCB that avoids switching oscillations.

Note: Melexis designed in a debouncing time of 1µs to the internal comparator due to the fact that the MLX10801 can be used with a wide range of inductances.

1.3. Electronic fuse applications

1.3.1. Electronic fuse schematic diagram

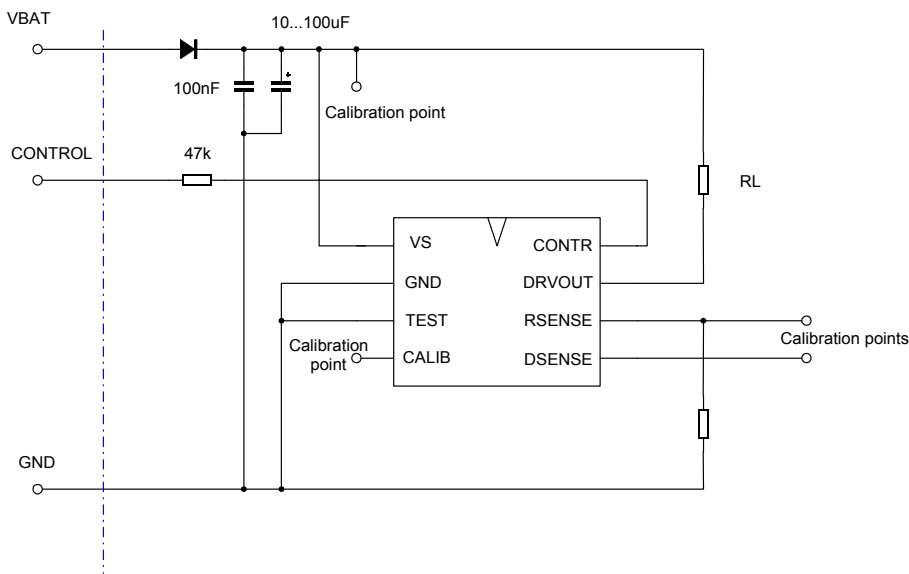

1.3.2. Electronic fuse application notes

The purpose of this application is the protection of an external load against overcurrent. In this mode, the switch mode regulator is disabled. The driver is permanently ON as long as the current remains below a specified level. Once this level is reached, the driver switches OFF and remains OFF until a POR is given.

A shutdown of the module due to overtemperature is also achievable if the internal or external temperature sensor is used.

2. Application pins

Nr.	Name	Function
1	VS	Supply Voltage
2	GND	Ground
3	TEST	MELEXIS test pin for test modes enable
4	CALIB	Serial clock/data for end of line programming
5	DSENSE	External diode pin for temperature measurement and temperature shutdown condition
6	RSENSE	External sense resistor pin for peak current detection
7	DRVOUT	Driver output
8	CONTR	Light control input, ON/OFF or dimming via PWM signal, sleep mode possibility

3. Absolute maximum ratings

Parameter	Symbol	Condition	Min	Max	Unit
Power supply	vs	DC	-0.3	28	V
		max. 2h	-0.3	36	V
		max. 0.5s	-0.3	40	V
Maximum input current in protection circuitry on any pin	iprot	In case of maximum supply ratings	-10	10	mA
Maximum input voltage on CONTR	vicontr	without external resistor	-0.3	18	V
		protected with external 47k resistor	-40V (0.5s)	40 (0.5s)	V
Maximum input voltage on RSENSE, DSENSE, TEST	vilv		-0.3	vdd+0,3	V
Maximum input voltage on CALIB	vicalib		-0.3	18	V
Maximum input voltage on DRVOUT	vdrvoutmax	with load			
		DC	-0.3	28	V
		max. 2h	-0.3	36	V
		max. 0.5s	-0.3	40	V
Maximum peak current on DRVOUT for MLX10801 in SOIC8	ipkdrvout			550	mA
Maximum average current on DRVOUT for MLX10801 in SOIC8	iavgdrvout			400	mA
Maximum peak current on DRVOUT for MLX10801 in MLPD8 5x5	ipkdrvout	*)		1.2	A
Maximum average current on DRVOUT for MLX10801 in MLPD8 5x5	iavgdrvout	*)		750	mA
Maximum junction temperature	tjunc	Lifetime	-40	130	C
		Dynamic	-40	150	C
		In case of EE Latch write	-40	85	C
		Storage temperature	-55	125	C
				150 (100h)	C
Ambient temperature range	tambient	-40C		105	C

Thermal resistance junction to ambient for MLX10801 in SOIC8	rth			120	K/W
Thermal resistance junction to ambient for MLX10801 in MLPD8 5x5 (Under consideration of the thermal application notes for MLPD packages published under www.carsem.com)	rth	*)		37	K/W

*) The parameters are only valid, in case the specified rth is insured by having a suitable heat sink capability on the PCB.

4. **Electrical characteristics**

Following characteristics are valid

- for the full temperature range of $T = -40^{\circ}\text{C}$ to $+105^{\circ}\text{C}$,
 - a supply range of $28\text{V} \geq V_S > 6\text{V}$
 - and the IC settling time after power on reset
- unless other conditions noted.

With $6\text{V} \geq V_S > v_{porh}$ analog parameters can not be guaranteed.

Note: The correct operation of the MLX10801 as a switching mode power supply for voltages lower than the nominal supply voltage is dependent on the forward bias voltage of the used LED.

The user must ensure that at low supply voltage the peak current threshold voltage on the RSENSE pin can be reached in order to keep the switching principle working.

If several pins are charged with transients above V_S and below GND, the sum of all substrate currents of the influenced pins should not exceed 10mA for correct operation of the device.

Normal operating supply voltage is supposed to be 13.8V.

Parameter	Symbol	Conditions	Limits			Units
			Min	Typ	Max	
Global parameters						
Maximum current during 40V load dump	ihv	$V_S=40\text{V}$ $\text{CONTR}=\text{H}$			10	mA
Normal supply current at highest DC voltage	inomdch	$V_S=28\text{V}$ $\text{CONTR}=\text{H}$			4	mA
Normal supply current	inom	$V_S=13.8\text{V}$ $\text{CONTR}=\text{H}$			2	mA
Sleep mode current	isleep	$V_S=13.8\text{V}$ Chip in sleep $T=25\text{C}$			105	μA
IC settling time						
IC settling time after power on reset	tsettle				300	μs
IC settling time after wake up	tssettle				300	μs
Oscillator related parameters						
The min/max specification influences directly all derived timings in the same deviation						
Oscillator frequency	fosc	(frequency can only be adjusted by Melexis during final parts test)	0.7	1.0	1.3	MHz
Debouncing time for sleep mode						
Debouncing time on CONTR for sleep mode	tdebsleep			32		ms
Wake up time	twakeup			8		μs

RESET related parameters						
Power on reset level, if VS is ramped up	vporh	(Reset is connected to the internal VDD, but vporh is measured on pin VS)			5.0	V
VDD related parameters (VDD stays only internal)						
5V supply voltage range	vdd	VS=13.8V	4.0		5.5	V
Monoflop related parameters						
Monoflop time	tmon	specified under 14.1				
Delay time generation for current reduction after power on reset						
Delay time	tdelay	specified under 14.1				
DAC reference related parameters						
DAC reference voltage	vdacref		2,75	3	3,25	V
RSENSE related parameters						
Input leakage current	ileakrsense	DRVOUT is switched off	-5		5	μA
Minimum threshold voltage on RSENSE of a given step	vrsensemin	specified under 14.1				
Maximum threshold voltage on RSENSE of a given step	vrsensemax	specified under 14.1				
Stability of a selected step due to temperature and supply influence and long term drift	vrsensestab		-3 ¹⁾		3 ¹⁾	%
DSENSE related parameters						
Output leakage current	ileakdsense	CONTR=0	-5		5	μA
Output current for temperature measurement	idsense	CONTR=1 (current can only be adjusted by Melexis during final parts test)	80		120	μA
Minimum temperature shutdown voltage on pin DSENSE of a given step	vdsensemin	specified under 14.1				
Maximum temperature shutdown voltage on pin DSENSE of a given step	vdsensemax	specified under 14.1				
Hysteresis between shutdown and switch on for a selected trimming step	vdsensehyst		13		35	mV
Stability of a selected step due to temperature and supply influence and long term drift	vdsensestab		-3 ¹⁾		3 ¹⁾	%

Temperature shutdown related parameters for the internal temperature sensor						
Forward bias voltage of internal diode at 25°C	vfdrt	idsense trimmed	630	660	690	mV
Forward bias voltage of internal diode at 105°C	vfdht	idsense trimmed	460	490	520	mV
CONTR related parameters						
Input leakage current	ileakcontr		-5		5	μA
Comparator digital threshold level L => H, switching point	vin5vhcontr	vdd=5V	0.6*vdd	0.65*vdd	0.7*vdd	V
Comparator digital threshold level H => L, switching point	vin5vlcontr	vdd=5V	0.3*vdd	0.35*vdd	0.4*vdd	V
			1.5	1.75	2	V
DRVOUT related parameters						
Input leakage of DRVOUT when switched off	ileakdrvout		-5		5	μA
On resistance of DRVOUT @Tj=150C	rdsdrvout				1.4	Ω
CALIB related parameters						
Pull down resistance of pin CALIB	rpdcalib		5	10	20	k

1) Guaranteed by design

5. *EE-Latch characteristics*

The NV memory carrying the trimming information is composed of an EEPROM latch. The data, that is written to this latch during final parts programming at Melexis or by the customer, is permanently stored in this latch, even after the chip is powered down.

Data retention	
25°C permanent ambient	20 years
55°C permanent ambient	20 years
85°C permanent ambient	10 years
125°C permanent ambient	1 year

6. *ESD/EMI recommendations for MLX10801*

- In order to minimise EMI, the PCB has to be designed according to EMI guidelines. Additional components may be needed, other than what is shown in the application diagrams, in order to comply with the EMI requirements.
- The MLX10801 is an ESD sensitive device and has to be handled according to EN100015 part 1.
- The MLX10801 will fulfil the requirements in the application according to the specification and to DIN 40839 part 1.
- The MLX10801 is designed with ESD protection >1000V HBM according to MIL883D.
- After ESD stress, the sleep mode current (specified in chapter 4) of the component can not be guaranteed anymore.

7. Automotive test pulses

The following chapter is valid for a completely assembled module. That means, that automotive test pulses are applied to the module and not to the single IC.

In the recommended application according to chapter 1, the reverse polarity diode together with the capacitors on the supply and the load dump protected IC itself protects the module against the automotive test pulses listed below.

The exact values of the capacitors for the application have to be figured out according to the automotive and EMI requirements.

No damage occurs for any of the test pulses.

A deviation of characteristics is allowed during pulse 1, 2, 4; the module returns to normal operation after the pulse without any additional action.

During test pulse 3a, 3b, 5 the module operates within characteristic limits.

Parameter	Symbol	Min	Max	Dim	Test condition, Functional status
Transient test pulses in accordance to DIN40839 part 1&3 and ISO7637 part 1&3, IC pin CONTR connected to IC pin VS via 47k, module schematics are according to application notes. Module acts as a single light source					
Test pulse #1 at module pin VBAT, GND	vpulse1	-100	0	V	5000 pulses, functional state C
Test pulse #2 at module pin VBAT, GND	vpulse2	0	100	V	5000 pulses functional state C
Test pulse #3a at module pin VBAT, GND	vpulse3a	-150	0	V	1h, functional state A
Test pulse #3b at module pin VBAT, GND	vpulse3b	0	100	V	1h, functional state A
Test pulse #4 at module pin VBAT, GND	vspulse4 vapulse4	-6 -5	-4 -2,5	V V	1 pulse, functional state C
Test pulse #5 at module pin VBAT, GND	vpulse5	26,5	86,5	V	1 pulse clamped to <=40V functional state C,

Description of functional status:

- A: All functions of the module are performed as designed during and after the disturbance.
- B: All functions of the module are performed as designed during and after the disturbance: However, one or more can deviate from specified tolerance. All functions return automatically to normal limits after exposure is removed. Memory functions shall remain class A.
- C: A function of the module is not performed as designed during disturbance but returns automatically to a normal operation after the disturbance

7.1. Test pulse definition

Test Pulse 1

Ri = 10R

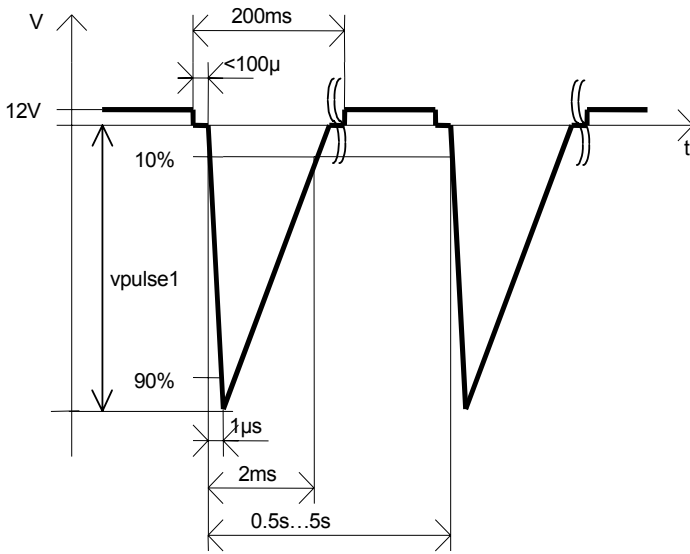

Test pulse 2

Ri=10R

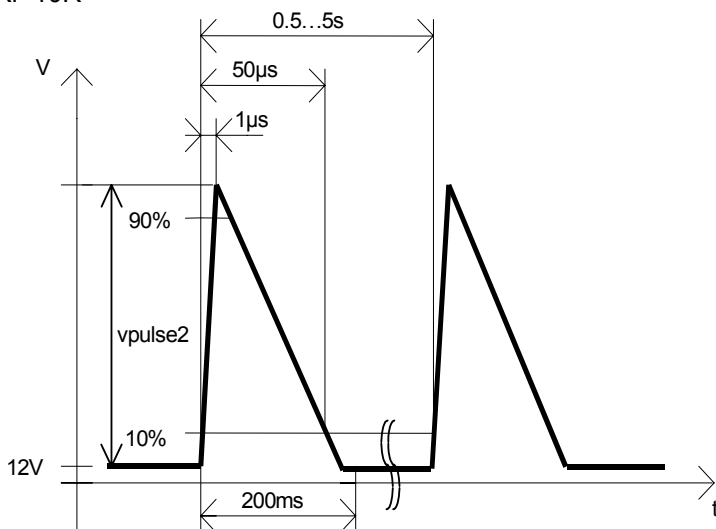

Test Pulse 3a

Ri = 50R

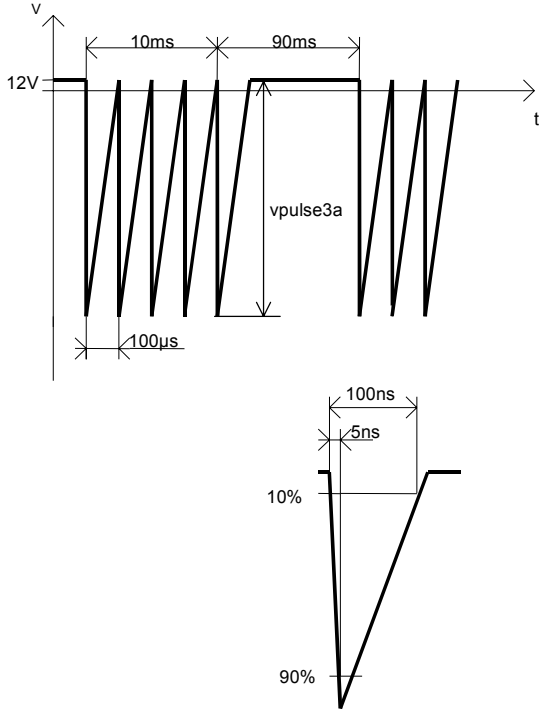

Test Pulse 3b

Ri = 50R

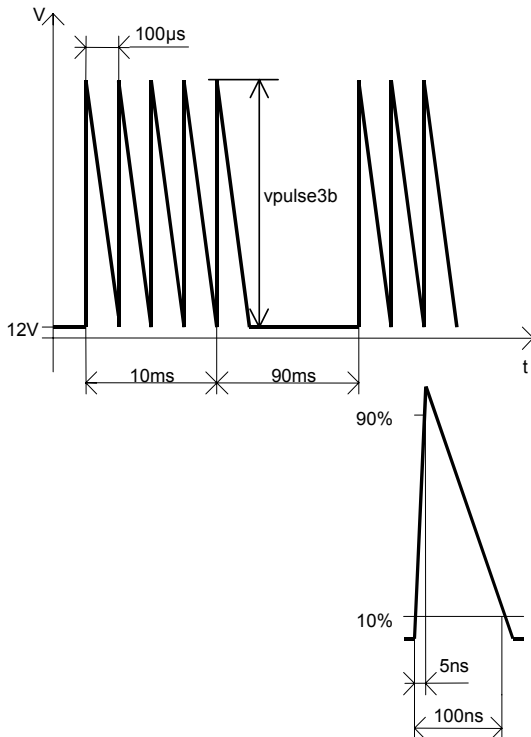

Test Pulse 4 (Cranking)

$R_i = 0.01R$

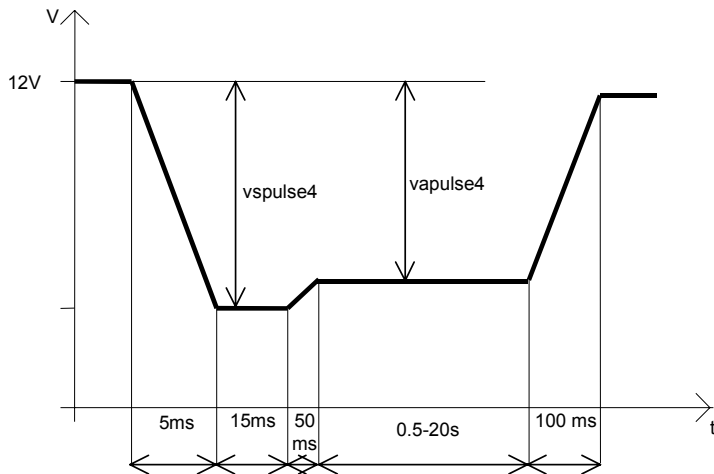

Test Pulse 5 (Load Dump)

$R_i = 0.5...4R$ (clamped to 40V during test)

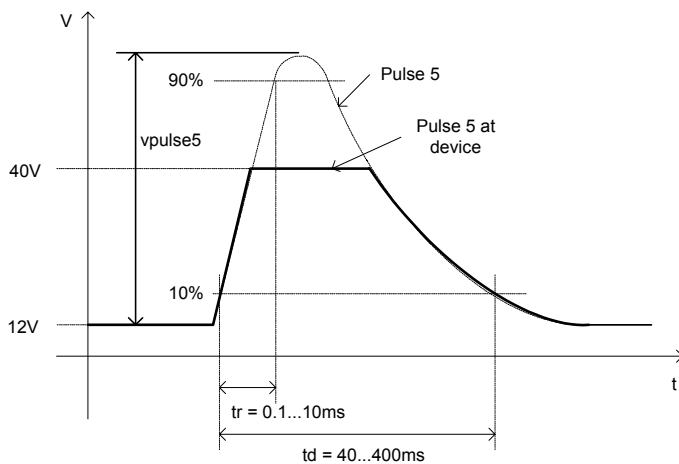

8. LED driving principle

8.1. General

The LED is driven by a switched mode power supply using an inductor as the energy storage element. This method has several advantages. The supply voltage has to be set down to the forward bias voltage of the LED. In ordinary applications this is achieved by a resistor with the following drawbacks:

- A resistor dissipates power which is transformed to heat
- Efficiency is reduced drastically
- The light output of the LED is dependent on the supply and the temperature of the resistor

The MLX10801 avoids this disadvantages as the following calculation shows (all values according to the Melexis demo board EVB10801, standard configuration with $L=220\mu\text{H}$, $R_{\text{SENSE}}=0.47\text{R}$):

Supposed:

$V_{\text{bat}} = 13.8\text{V}$
 $V_{\text{fLED}} \approx 3.4\text{V}$
 $I_{\text{fLED}} \approx 350\text{mA}$
 $V_{\text{f1}} \approx 0.7\text{V}$ (reverse polarity diode)
 $V_{\text{f2}} \approx 0.7\text{V}$ (free wheel diode)
 $V_{\text{RSENSE}} \approx 0.4\text{V}$ (@ I_{fLED} , $R_{\text{SENSE}}=0.47\text{R}$)
 $V_{\text{RDS ON}} \approx 0.3\text{V}$ (@ I_{fLED})
 $V_{\text{Coil}} \approx 0.2\text{V}$ (@ I_{fLED})

Efficiency using a simple resistor:

Efficiency n : $n = V_{\text{fLED}} / V_{\text{bat}} \approx \mathbf{25\%}$

Efficiency using the MLX10801:

The following calculation is an approximation only, due to the fact the coil current is not constant. It is therefore calculated with average currents.

- 1) During OFF time, the coil acts as the storage element and puts its energy to the free wheel diode and the LED:
 $n_1 = V_{\text{fLED}} / (V_{\text{fLED}} + V_{\text{f2}} + V_{\text{Coil}}) \approx 79\%$
- 2) During ON time, current flows through the reverse polarity diode, LED, coil, FET driver and RSENSE, which causes the following voltage drops:
 $n_2 = V_{\text{fLED}} / (V_{\text{fLED}} + V_{\text{f1}} + V_{\text{Coil}} + V_{\text{RDS ON}} + V_{\text{RSENSE}}) \approx 68\%$
- 3) ON and OFF times are in ratio of roughly 40:60
 Efficiency n : $n = (n_1 * 0.4 + n_2 * 0.6) = \mathbf{72.4\%}$

Measurements have given an efficiency of about 70% and confirm this estimation. Note, that the ratio of ON and OFF time depends on many factors like supply voltage, coil inductance, forward bias voltage etc. and is therefore an application specific value. For ordinary applications, efficiency ranges from about 65% - 75%.

8.2. The principle in detail

The driver is switched on until a maximum current through the LED is reached. This maximum current is programmable by the customer. After reaching the maximum current, the driver is switched off for an adjustable monoflop time that is formed by a counter compare unit. The monoflop time is also programmable by the customer. Both parameters, the peak current threshold voltage and the monoflop time, create an ON/OFF period to form an average current through the LED. By programming these parameters, an adjustment of the average load current is possible in a wide range.

Note: The current sense comparator has a typical debouncing time of 1 μ s as shown in the block diagram. This delay time prevents the driver from being switched off due to short term switching oscillations etc. When working with very short monoflop times this time has to be taken into account for calculations.

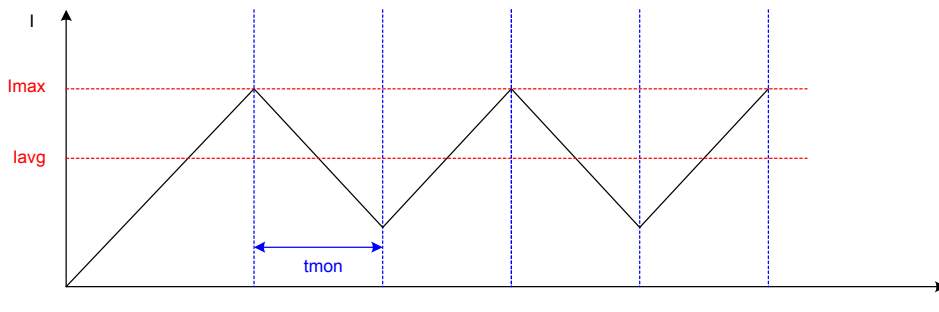

Note: The circuit is active only in case CONTR=H.

By applying a PWM signal on CONTR, the LED can be dimmed from 0% to 100%.

CONTR=0	LED with 0%
CONTR=PWM	LED dimmed with PWM
CONTR=H	LED with 100%

Dimming can also be achieved by applying a PWM directly to the module supply.

IC settling times have always to be considered in PWM mode. Please refer also to chapter 1.1.3 for additional PWM frequency considerations.

With a configuration bit, a pseudo random generator can be applied to the last 3 LSBs of the 6 setting bits for the monoflop time. The pseudo random generator runs with the clock derived out of the monoflop time and adds a random distribution on these 3 LSBs. Therefore, the monoflop time gets a **random** variation from its trimmed value. This occurs in every monoflop period. It will influence the average current in the same manner. By using this **jitter mode** feature, the EMI behaviour of the complete module is improved, due to the variation of the otherwise fixed switching frequency. Please refer to 14.2 for additional information.

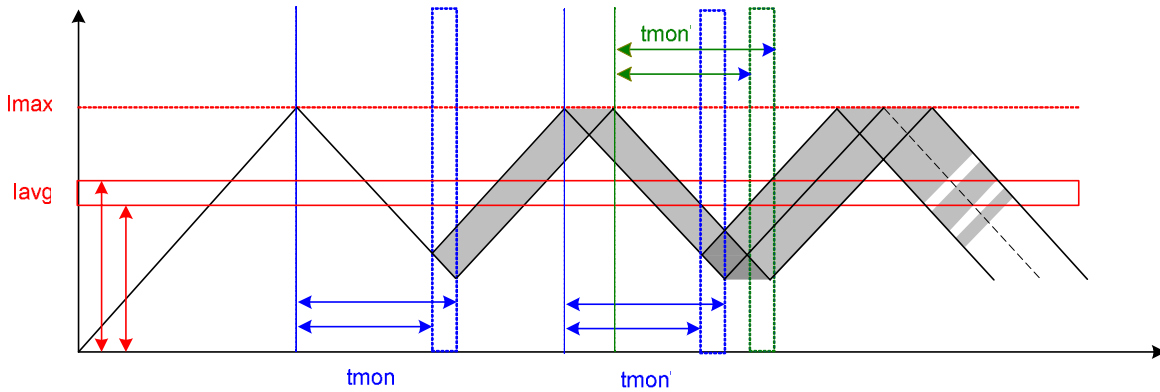

jitter mode

8.3. Coil inductance, EMI and selected parameter set

The inductance L of a coil describes the amount of magnetical energy that can be stored in it. Consequently, high inductive coils will be discharged less than low inductive coils in a given time.

Generally the coil can be driven in two different ways:

- 1) The coil will only be discharged partially. That means the coil still carries a significant amount of energy when going from discharging to charging. In that moment the charging current rises immediately to the coil current that was flowing just before switching. This is connected with large di/dt transients on the RSENSE pin that have a negative impact on EMI.
- 2) The coil will be discharged completely. Thus, at the end of a discharging cycle, the coil doesn't carry energy anymore. With the next charging cycle, current increases steadily from around zero. This way, large di/dt transients are completely avoided.
Care has to be taken when working in jitter mode. In this case, monoflop time (=discharging time) is not constant but varies in a certain range (see chapter 14.2 for details). It must be ensured that only the longest possible monoflop time completely discharges the coil. Otherwise the coil is discharged before the monoflop time ends which results in a loss of efficiency.

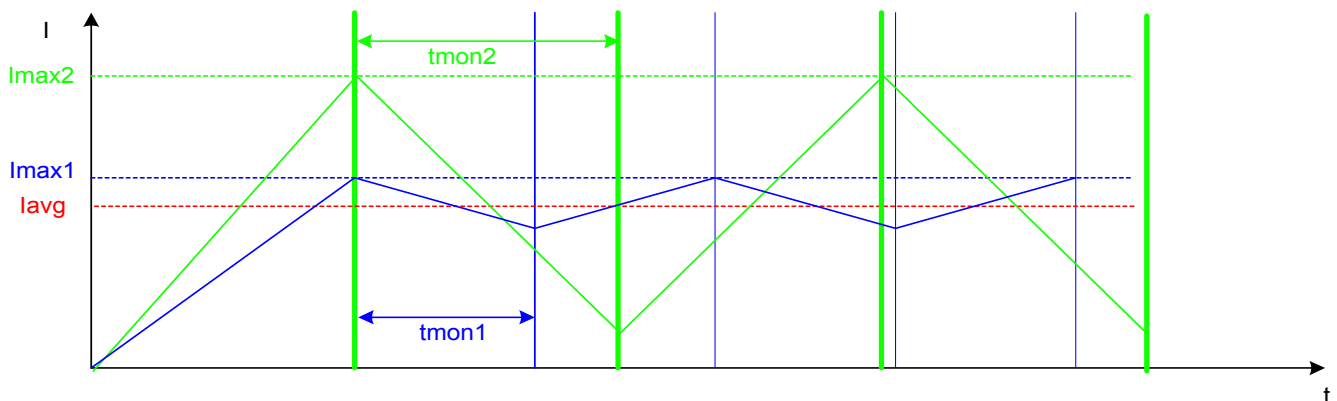

Conclusion: In most cases the coil is driven in a combination of both ways. A tradeoff has to be made between EMI behaviour and maximum allowed LED current. By varying these parameters, an optimum can be found for virtually every application.

Below are some examples for typical parameter sets given for a 350mA LED current and the following application data:

Standard application used according to 1.1.1:

- RSENSE = 0.47R (1R)
- LED: Luxeon LXHL-MW1C
- L = 220 μ H, 470 μ H

L=470 μ H, RSENSE=1R

```
;Selection of temperature sensor (1-internal). Bit[19].  
1  
;Jitter enabled (1-enabled). Bit [18].  
1  
;Delay after POR. Bits [17:15].  
0 0 0  
;Temperature shut off. Bits [14:10].  
0 1 0 0 1  
;TMonoflop time. Bits [9:4].  
1 0 0 1 0 0  
;Peak current. Bits [3:0].  
1 1 1 1  
w
```

L=220 μ H, RSENSE=0.47R

```
;Selection of temperature sensor (1-internal). Bit[19].  
1  
;Jitter enabled (1-enabled). Bit [18].  
1  
;Delay after POR. Bits [17:15].  
0 0 0  
;Temperature shut off. Bits [14:10].  
0 1 0 0 1  
;TMonoflop time. Bits [9:4].  
0 1 1 1 0 0  
;Peak current. Bits [3:0].  
0 1 1 1  
w
```

L=100 μ H, RSENSE=0.47R

```
;Selection of temperature sensor (1-internal). Bit[19].  
1  
;Jitter enabled (1-enabled). Bit [18].  
1  
;Delay after POR. Bits [17:15].  
0 0 0  
;Temperature shut off. Bits [14:10].  
0 1 0 0 1  
;TMonoflop time. Bits [9:4].  
0 0 1 1 0 0  
;Peak current. Bits [3:0].  
0 1 1 1  
w
```



8.4. Switching frequency considerations and constant light output

As already shown, the switching frequency depends on the peak current as well as on the monoflop time for a given coil. Furthermore it depends on the coil inductance itself.

Due to the principle of switch mode power supplies, the current through the LED is kept constant for any supply changes. The parameter that changes in order to keep the current constant is the switching frequency itself. The lower the supply voltage, the lower the switching frequency. Furthermore, the supply current is affected by supply changes: with an increasing supply voltage the average supply current decreases.

Melexis delivers the MLX10801 with a pre-trimmed parameter set according to chapter 15, where an average switching frequency for a supply voltage of 13.8V is given.

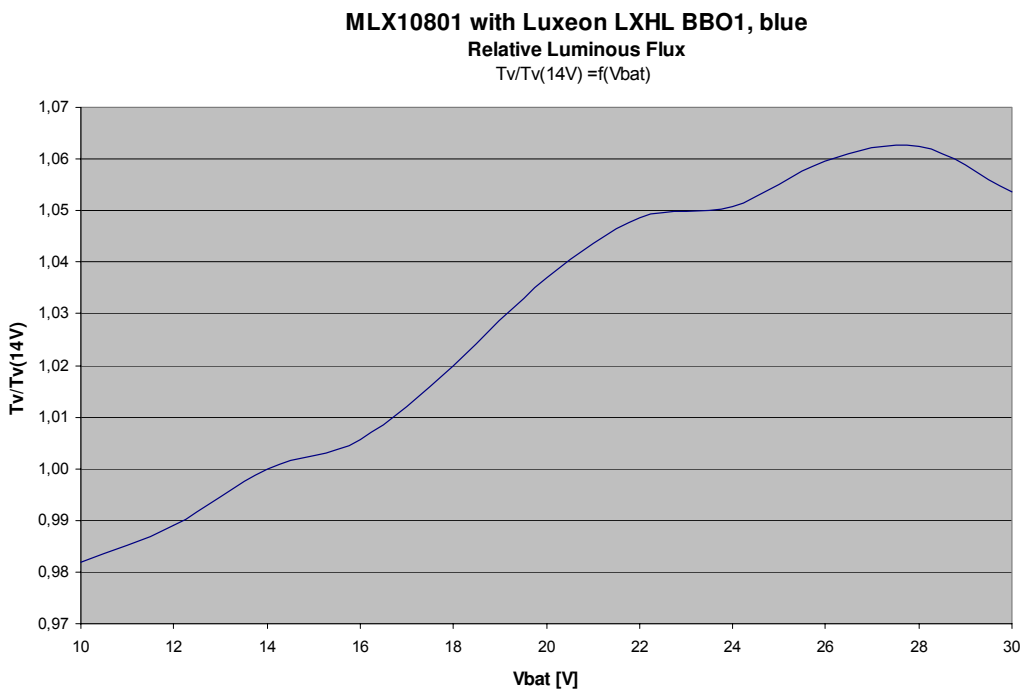
The graph below shows the relative luminous flux versus the power supply for a **typical** application. The luminous flux at 14V has been set to 100%. The graph indicates that the light output is not as dependent on supply changes.



9. Coil driving principle

9.1. General

Coils like relays or micro valves consume a relatively large amount of energy. At the moment of switching on, energy is needed in order to switch a relay or a micro valve to the ON position. Once this position is reached, the energy can be reduced drastically, while still keeping the mechanics of the relay or micro valve activated.

9.2. The principle in detail

After power on reset, a delay time t_{delay} can be enabled, which disables the peak current detection during that time. This delay time can be selected as described in 14.

The maximum current I_{max} that can flow during t_{delay} , is just dependent on the omic resistance of the selected coil. After t_{delay} , the trimmed configuration is valid and the current drops down to the trimmed current value I_{avg} .

Due to the fact that the inductance of relays and micro valves is quite high, the monoflop operation in the range of microseconds does not have much of an impact on the average current. So, in this configuration the selected peak current is nearly the same as the average current. The monoflop time should be selected according to the inductance of the selected coil and for the best EMI behaviour.

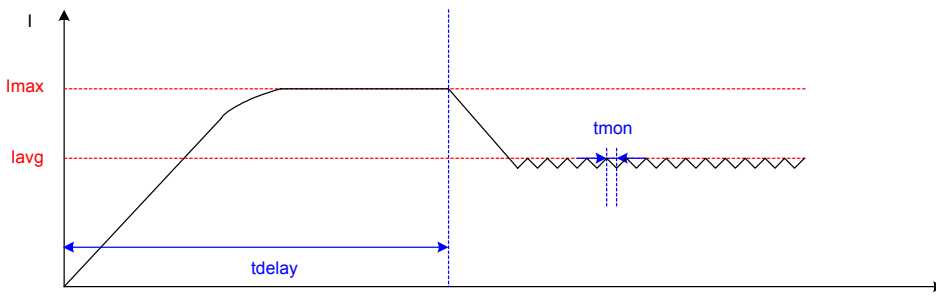

10. Electronic fuse principle

The principle is very simple. The monoflop will not be used and stays deselected. This way, the driver is always on and the current of a given load is sensed by RSENSE. If it exceeds the specified limit or the selected shutdown temperature, the module will be switched off. It can only be switched on again by a power on reset to the system or by reducing the module temperature.

11. Sleep mode

In case CONTR=0 for $t > t_{debsleep}$, the MLX10801 goes to sleep mode, which reduces the IC current drastically. Only the internal regulator and the input comparator for CONTR are still working.

In case CONTR=1 again, the chip is waken up after $t > t_{wake up}$.
The settling time for wake up, given in chapter 4, has to be considered.

12. Temperature shutdown

The temperature shutdown feature can be enabled or disabled. In case it is enabled, an internal or external diode can be used as temperature sensor.

The internal temperature sensor is used to protect the chip (FET driver) from overtemperature. If the adjustable temperature shutdown voltage, which is in fact the forward bias voltage of the diode, is reached, the IC shuts down. An external temperature sensor is usually used to protect the load (LED) from overtemperature. Therefore it should be thermally connected to the load.

Between the temperature shutdown and release point, there is a hysteresis in order to avoid oscillations. When this point is reached, the IC automatically returns to its normal mode.
The hysteresis is specified in chapter 4.

The thermal behaviour of the system should be characterised during the design-in of the product by the customer. The chip can be programmed for a fixed temperature shutdown voltage thereafter during the end of line programming.

For a system that is designed for thermal conditions, temperature shutdown may not be needed. In this case, the temperature shutdown can be disabled completely.

13. Load dump protection

The MLX10801 is protected against 40V load dump, in case the application proposals described under 1 are used.

14. The calibration

14.1. The internal control register

The internal control register consists of the following bits.
Bits are shifted in from MSB to LSB, starting with Bit19 and ending with Bit0.

Nr of Bits	Bits	Scope	Remark			
4	0...3	Peak current shutdown calibration data. The DAC behaviour is monotonic. vrsensetyp stepwise is 30mV				
		Bits	vrsensemin	vrsensetyp	vrsensemax	
		3 2 1 0				
		0 0 0 0	-10 %	90 mV	+10 %	
		0 0 0 1	-10 %	120 mV	+10 %	
...						
	1 1 1 1	-10 %	540 mV	+10 %		
6	4...9	Monoflop time calibration data.				
		Bits	Monoflop time tmon			
		9 8 7 6 5 4				
		0 0 0 0 0 0	Monoflop disabled			
		0 0 0 0 0 1	1 μ s			
0 0 0 0 1 0	2 μ s					
...						
	1 1 1 1 1 1	63 μ s				
5	10...14	Temperature shutdown calibration data. The DAC behaviour is monotonic. vdsensetyp stepwise is 10mV				
		Bits	vdsensemin	vdsensetyp	vdsensemax	
		14 13 12 11 10				
		0 0 0 0 0	Temperature shutdown disabled			
		0 0 0 0 1	-10 %	300mV	+10 %	
0 0 0 1 0	-10 %	310mV	+10 %			
...						
	1 1 1 1 1	-10 %	600mV	+10 %		
3	15...17	Delay generation after power on reset for current reduction.				
		Bits	Delay time tdelay			
		17 16 15				
		0 0 0	Delay time generation disabled			
		0 0 1	1 ms			
0 1 0	2 ms					
0 1 1	4 ms					
1 0 0	8 ms					
1 0 1	16 ms					
1 1 0	32 ms					
1 1 1	64 ms					
		Bit cleared	Bit set			
1	18	Pseudo random generator is NOT applied to the monoflop time generation.	Pseudo random generator is applied to the monoflop time generation.			
1	19	External diode temperature sensor is used at DSENSE.	Internal temperature diode sensor is used at DSENSE.			
4	20...23	Temperature shutdown current source calibration data.	Only adjustable by Melexis			
5	24...28	Oscillator frequency calibration data.				
5	29...33	DAC reference calibration data.				

14.2. The Influence of the pseudo random generator to the monoflop time

Code dez	Code bin	Monoflop-Time	Jitter min	Jitter max	1/ Monoflop-Time	1/Jitter max	1/Jitter min
		[us]	[us]	[us]	[kHz]	[kHz]	[kHz]
1	000001	1	1	7	1000,0	1000,0	142,9
2	000010	2	1	7	500,0	1000,0	142,9
3	000011	3	1	7	333,3	1000,0	142,9
4	000100	4	1	7	250,0	1000,0	142,9
5	000101	5	1	7	200,0	1000,0	142,9
6	000110	6	1	7	166,7	1000,0	142,9
7	000111	7	1	7	142,9	1000,0	142,9
8	001000	8	8	14	125,0	125,0	71,4
9	001001	9	8	14	111,1	125,0	71,4
10	001010	10	8	14	100,0	125,0	71,4
11	001011	11	8	14	90,9	125,0	71,4
12	001100	12	8	14	83,3	125,0	71,4
13	001101	13	8	14	76,9	125,0	71,4
14	001110	14	8	14	71,4	125,0	71,4
15	001111	15	8	14	66,7	125,0	71,4
16	010000	16	16	22	62,5	62,5	45,5
17	010001	17	16	22	58,8	62,5	45,5
18	010010	18	16	22	55,6	62,5	45,5
19	010011	19	16	22	52,6	62,5	45,5
20	010100	20	16	22	50,0	62,5	45,5
21	010101	21	16	22	47,6	62,5	45,5
22	010110	22	16	22	45,5	62,5	45,5
23	010111	23	16	22	43,5	62,5	45,5
24	011000	24	24	30	41,7	41,7	33,3
25	011001	25	24	30	40,0	41,7	33,3
26	011010	26	24	30	38,5	41,7	33,3
27	011011	27	24	30	37,0	41,7	33,3
28	011100	28	24	30	35,7	41,7	33,3
29	011101	29	24	30	34,5	41,7	33,3
30	011110	30	24	30	33,3	41,7	33,3
31	011111	31	24	30	32,3	41,7	33,3
32	100000	32	32	38	31,3	31,3	26,3
33	100001	33	32	38	30,3	31,3	26,3
34	100010	34	32	38	29,4	31,3	26,3
35	100011	35	32	38	28,6	31,3	26,3
36	100100	36	32	38	27,8	31,3	26,3
37	100101	37	32	38	27,0	31,3	26,3
38	100110	38	32	38	26,3	31,3	26,3
39	100111	39	32	38	25,6	31,3	26,3
40	101000	40	40	46	25,0	25,0	21,7
41	101001	41	40	46	24,4	25,0	21,7
42	101010	42	40	46	23,8	25,0	21,7
43	101011	43	40	46	23,3	25,0	21,7
44	101100	44	40	46	22,7	25,0	21,7
45	101101	45	40	46	22,2	25,0	21,7
46	101110	46	40	46	21,7	25,0	21,7
47	101111	47	40	46	21,3	25,0	21,7
48	110000	48	48	54	20,8	20,8	18,5
49	110001	49	48	54	20,4	20,8	18,5
50	110010	50	48	54	20,0	20,8	18,5
51	110011	51	48	54	19,6	20,8	18,5
52	110100	52	48	54	19,2	20,8	18,5
53	110101	53	48	54	18,9	20,8	18,5
54	110110	54	48	54	18,5	20,8	18,5
55	110111	55	48	54	18,2	20,8	18,5
56	111000	56	56	62	17,9	17,9	16,1
57	111001	57	56	62	17,5	17,9	16,1
58	111010	58	56	62	17,2	17,9	16,1
59	111011	59	56	62	16,9	17,9	16,1
60	111100	60	56	62	16,7	17,9	16,1
61	111101	61	56	62	16,4	17,9	16,1
62	111110	62	56	62	16,1	17,9	16,1
63	111111	63	56	62	15,9	17,9	16,1

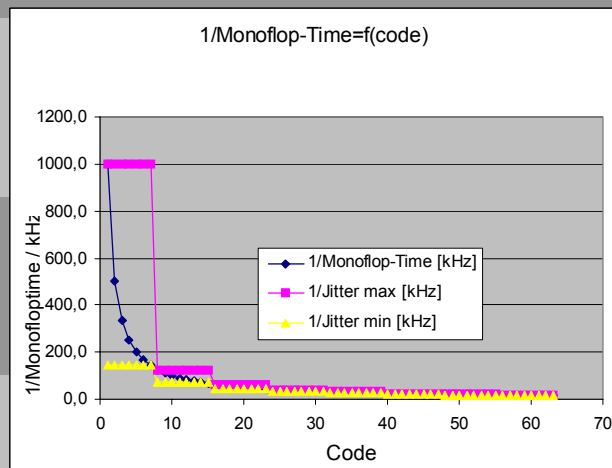
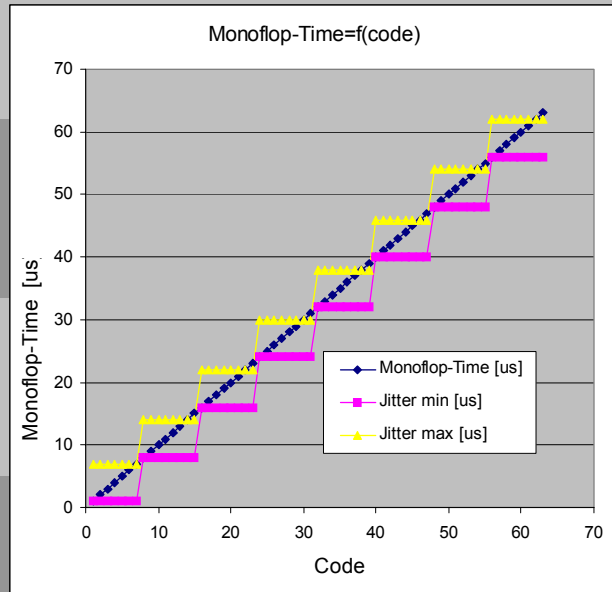

In case the pseudo random generator is enabled, a random value is applied to the 3 LSBs of the trimmed monoflop time. The table above shows the relation between programmed monoflop time and the minimum/maximum jitter, which can be seen in the related diagrams. All values are typical values. Note, that this is not the drivers switching frequency but only the discharging cycle of a full switching period.

14.3. The calibration interface

The calibration interface consists of two blocks: The calibration pin (threshold detection) and the serial interface. The calibration pin is a multi level pin and handles the following functions:

- sending clock and data to the serial interface
- latching the data to the EE-Latches
- programming the data to the EE-Latches

The pin itself is pulled down internally.

On pin CALIB, comparators are connected with the following threshold levels:

Threshold level	Scope
0	Normal application mode
3*VS/10	Detects a logic "L" and generates a clock pulse
5*VS/10	Detects a logic "H" and generates a clock pulse
7*VS/10	Latches the data from the serial interface to the EE-Latches and generates a clock pulse. Data is not stored permanently but will be immediately used
9*VS/10	Programmes the data permanently to the EE-Latches and generates a clock pulse. <u>Attention:</u> <ul style="list-style-type: none"> • A write cycle has to take 4ms...6ms. The user has to insure this time in order to guarantee the specified EE-Latch data retention. • Note, that the interface is fully static, thus only the threshold level is important. However, the maximum transmission rate is limited to 20kBaud, which allows 50µs/bit. • Note, that the CALIB pin needs to be left open (internally pulled down) in normal application mode. If the threshold for programming is reached mistakenly (e.g. by applying VBAT to pin CALIB), random data of the internal registers of the serial interface will be programmed to the EE-Latches! It is even better to pull down CALIB hard to GND after programming to avoid fail programming • It is not possible to write a single bit to the EEPROM. A programming cycle always consists of ALL bits of the scan chain.

Following graph shows the driving of the pin and the modes:

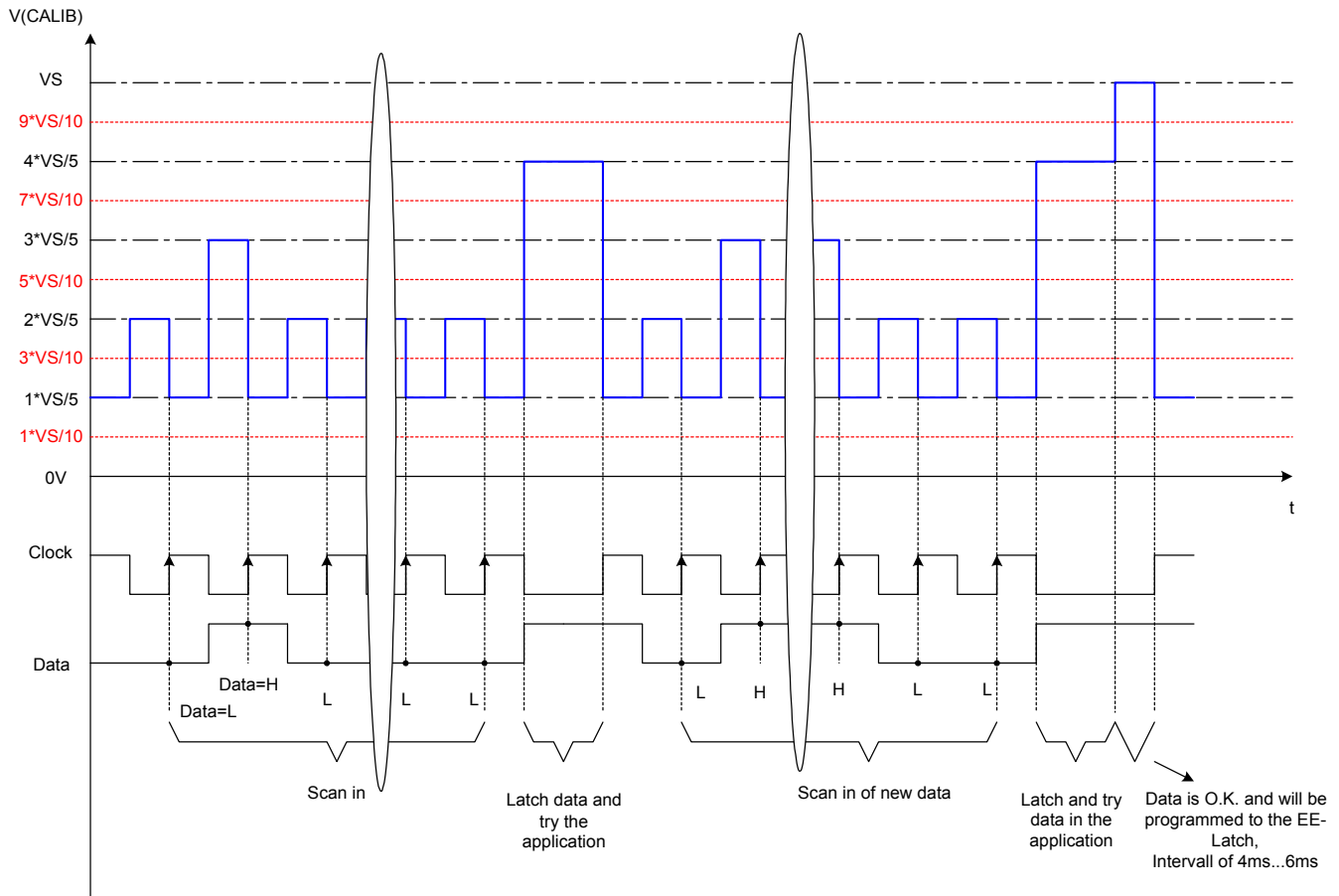

14.4. The calibration procedure

The simple end of line calibration algorithms described below give the possibility to use only

- VS,
- GND,
- CALIB as communication interface. No other signals need to be driven.

However, depending on the application requests, other calibration algorithms which stimulate RSENSE and/or DSENSE are also possible.

14.4.1. Calibration procedure for LED driver applications

An end of line calibration of LED modules is recommended due to the variation in brightness of high power LEDs at a given current. Assembled modules need to have the CALIB pin available for programming by the customer during the end of line programming. Optical feedback, such as a light meter, can be used during the end of line calibration for the adjustment of the LED brightness.

The following configuration parameters are trimmed using a configuration, that has been figured out during the design in phase:

- Monoflop time
- Jitter enabled or disabled
- Temperature shutdown voltage
- Internal or external temperature sensor used
- Delay generation after power on reset disabled

The following algorithm can be used for the configuration of the LED module:

- A) A start value for the peak current threshold voltage is used.
- B) It is loaded and latched via CALIB together with the data above.
- C) A power on reset is applied and the application is started.
- D) The light output is measured and a new code for the peak current threshold voltage is calculated.
- E) The new code is loaded and latched via CALIB together with the data above.
- F) The routines C)...E) are executed until the specified light output is reached.

14.4.2. Calibration procedure for coil driver applications:

The module is assembled completely. End of line programming is performed at the customers side. The CALIB pin must be available for programming.

An ampere meter is connected in the supply line of the module.

The following configuration parameters are uploaded using a configuration, that has been figured out during the design in phase:

- Peak current threshold voltage
- Monoflop time
- Delay generation after power on reset
- Jitter enabled or disabled
- Temperature shutdown voltage
- Internal or external temperature sensor used

The following algorithm can now be used:

- A) The parameters above are uploaded and latched via CALIB.
- B) A power on reset is applied and the application is started.
- C) The relay or micro valve current is measured and must be in spec after tdelay.

14.4.3. Calibration procedure for electronic fuse applications:

The module is assembled completely. End of line programming is performed at the customers side. The CALIB pin must be available for programming.

The following configuration parameters are uploaded using a configuration, that has been figured out during the design in phase:

- Peak current threshold voltage
- Monoflop (stays deselected)
- Delay generation after power on reset (is switched off)
- Jitter (stays disabled)

- Temperature shutdown voltage
- Internal or external temperature sensor is used

The following algorithm can now be used:

- A) The parameters above are uploaded and latched via the CALIB pin.
- B) A power on reset is applied and the application is started.
- C) The application is working. Adding additional current to the load will switch off the load if the sum of both currents is larger than the trimmed limit.

15. Data content of delivered parts

All parts delivered to a customer have the following default parameter set, which had been programmed to the IC during Melexis' final part test. It is up to the user to modify this data depending on application requests (see also chapter 14).

Application diagram according to 1.1.1:

- RSENSE = 0.47R,
- L= 220µH,
- LED: Luxeon LXHL-MW1C.

Meaning	Parameter	Type	Unit
Average current	iavg	350	mA
Resulting average switching frequency (jitter mode enabled) at 13.8V	fdrvout	24	kHz
Delay generation switched off			
Jitter mode enabled			
Internal temperature sensor selected, calibrated to 150°C IC junction temperature for thermal IC protection			

The related parameter set file looks like following:

```
;Selection of temperature sensor (1-internal). Bit[19].
1
;Jitter enabled (1-enabled). Bit [18].
1
;Delay after POR. Bits [17:15].
0 0 0
;Temperature shut off. Bits [14:10]. (code 9 = 380mV).
0 1 0 0 1
;TMonoflop time. Bits [9:4]. (code 28 = 28µs)
0 1 1 1 0 0
;Peak current. Bits [3:0]. (code 7 = 300mV)
0 1 1 1
w
```

16. Mechanical Data

16.1. Mechanical data of the MLX10801 in SOIC8

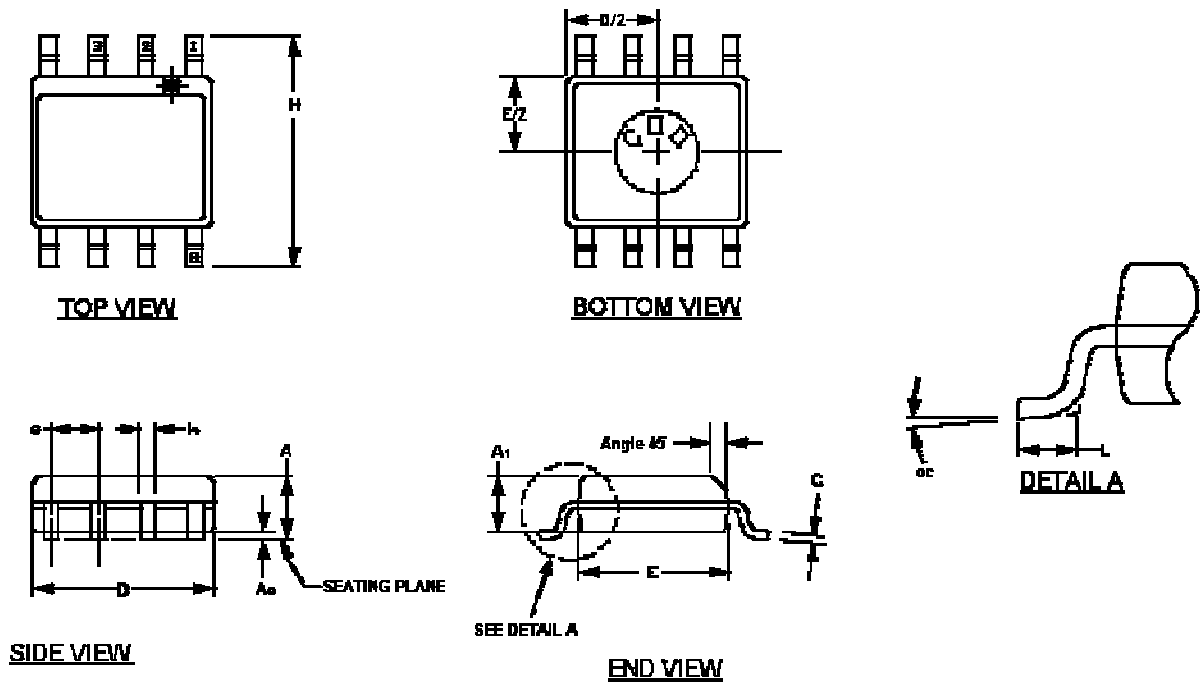

	DIMENSIONS						Note
	INCHES			MILLIMETERS			
	MIN.	NOM.	MAX	MIN.	NOM.	MAX	
A	.061	.064	.068	1.55	1.63	1.73	
A1	.004	.006	.0098	0.127	0.15	0.25	
A0	.055	.058	.061	1.40	1.47	1.55	
B	.0138	.016	.0192	0.35	0.41	0.49	
C	.0075	.008	.0098	0.19	0.20	0.25	
D	.189	.194	.196	4.80	4.93	4.98	
E	.150	.155	.157	3.81	3.94	3.99	
e		.050			1.27		
H	.230	.236	.244	5.84	5.99	6.20	
h	.010	.013	.016	0.25	0.33	0.41	
L	.016	.025	.035	0.41	0.64	0.89	
oc	0°	5°	8°	0°	5°	8°	Degrees
X	.085	.093	.100	2.16	2.36	2.54	



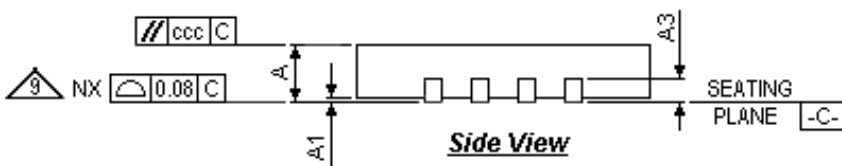
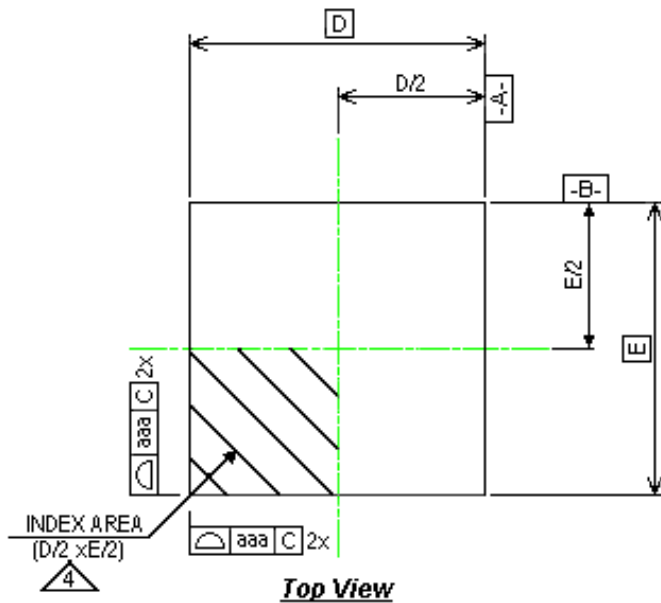

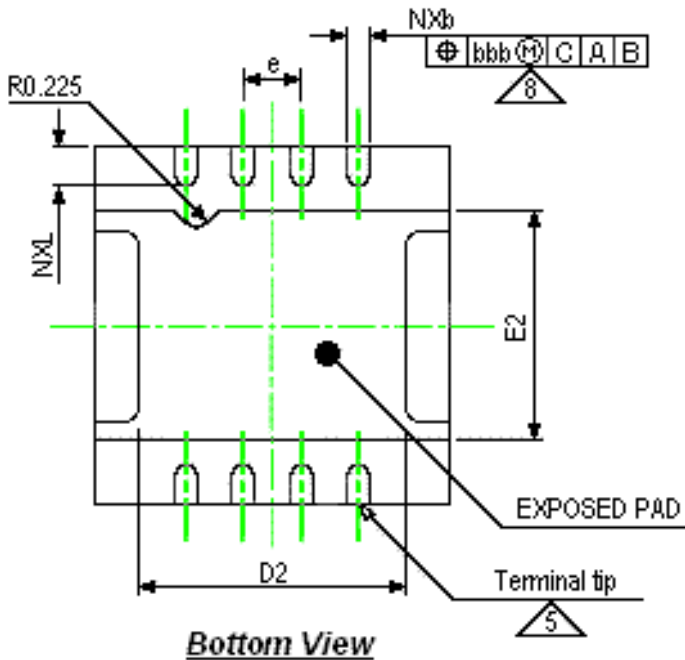
16.2. Mechanical data of the MLX10801 in MLPD8 5x5





COMMON DIMENSION				
SYMBOL	MIN	NOM	MAX	NOTE
A1	0	0.02	0.05	
A3		0.20 REF		
r	b(min)/2			
Tolerances of form and position				
aaa		0.15		
bbb		0.10		
ccc		0.10		

Note:

1. Dimensioning and tolerancing conform to ASME Y14.5M-1994.
2. All dimensions are in millimeters. Angles is in degrees.
3. N is the total number of terminals.
4.  The terminal #1 identifier and terminal numbering convention shall conform to JESD 95-1 SPP-012.
5.  ND and NE refers to the number of terminals on each D and E side respectively.
6. Depopulation is possible in a symmetrical fashion.
7. NJR-1 refers to Non Jedec Registered package.
8.  Dimension b applies to metallized terminal and is measured between 0.25mm and 0.30mm from terminal tip.
9.  Coplanarity applies to the exposed heat sink slug as well as the terminals.
10. For a complete set of dimension, please refer to the common dimension and tolerances on page 2.

VARIATIONS												
SYM-BOL	NJR-1			NOTE	NJR-2			NOTE	NJR-2			NOTE
	PAD SIZE TYPE A				PAD SIZE TYPE B				PAD SIZE TYPE B			
	MIN	NOM	MAX		MIN	NOM	MAX		MIN	NOM	MAX	
	A	0.80	0.90		1.00		0.80		0.90	1.00		
b	0.25	0.30	0.35	8	0.25	0.30	0.35	8				
D	5.00 BSC				5.00 BSC							
D2	3.26	3.41	3.51		3.65	3.80	3.90					
E	5.00 BSC				5.00 BSC							
E2	3.00	3.15	3.25		3.05	3.20	3.30					
e	0.80 BSC				0.80 BSC							
L	0.45	0.55	0.65		0.45	0.55	0.65					
N	8			3	8			3				
ND	4			5		4		5				
NE	0			5		0		5				
NOTE	---				---				---			
REF	---				---				---			
ISSUE	---				---				---			

16.3. Melexis standard soldering information

This Melexis device is classified and qualified regarding soldering technology, solderability and moisture sensitivity level, as defined in this specification, according to following test methods:

- IPC/JEDEC J-STD-020
Moisture/Reflow Sensitivity Classification For Nonhermetic Solid State Surface Mount Devices (classification reflow profiles according to table 5-2)
- EIA/JEDEC JESD22-A113 Preconditioning of Nonhermetic Surface Mount Devices Prior to Reliability Testing (reflow profiles according to table 2)
- CECC00802 Standard Method For The Specification of Surface Mounting Components (SMDs) of Assessed Quality
- EIA/JEDEC JESD22-B106 Resistance to soldering temperature for through-hole mounted devices
- EN60749-15 Resistance to soldering temperature for through-hole mounted devices
- MIL 883 Method 2003 / EIA/JEDEC JESD22-B102

Solderability

For all soldering technologies deviating from above mentioned standard conditions (regarding peak temperature, temperature gradient, temperature profile etc) additional classification and qualification tests have to be agreed upon with Melexis.

The application of Wave Soldering for SMD's is allowed only after consulting Melexis regarding assurance of adhesive strength between device and board.

Based on Melexis commitment to environmental responsibility, European legislation (Directive on the Restriction of the Use of Certain Hazardous substances, RoHS) and customer requests, Melexis has installed a Roadmap to qualify their package families for lead free processes also.

Various lead free generic qualifications are running, current results on request.

For more information on Melexis lead free statement see quality page at our website:

<http://www.melexis.com/html/pdf/MLXleadfree-statement.pdf>

17. History record

Rev.	No.	Change	Date
1	1	Creation	21.09.01
2	1	IC settling times added	27.09.01
	2	Minimum application diagram added	
	3	Efficiency calculation had been corrected	
	4	Calibration of the monoflop time had been changed	
	5	Debouncing time on CONTR for going to sleep mode added	
	6	Maximum ambient temperature for chip operation set to 105C	
	7	rth of the SOIC8 inserted, inomdch added	
	8	vs, ihv, inom, rdsdrvout adjusted	
3	1	Pseudo random generator on the monoflop time added in order to improve EMI	04.10.01
4	1	Changes due to coil driver applications and electronic fuse applications	19.10.01
	2	tbds have been defined	
5	1	Device number MLX10801 assigned	16.11.01
	2	Typing mistakes corrected	
	3	Maximum supply ratings now at 28V for industrial micro valve applications	
	4	tssettle set to 300us, -vbe replaced to -0.3V, ihv (typical) removed	
	5	Reset related parameters adjusted	
	6	Hysteresis for the temperature shutdown has been put in the block diagram	
	7	CALIB related parameters added to the electrical characteristics	
6	1	Possible caps added for EMI improvement	15.01.02
	2	Calibration procedure adjusted	
	3	Gain stages out of the RSENSE and DSENSE path have been removed	
	4	DSENSE is in tristate in case the internal temperature sensor is used	
	5	Twakeup=8us introduced in order not to wake up in case of HF on the pin CONTR	
7	1	Pins DSENSE and RSENSE exchanged: pinning had been finalised	14.02.02
	2	Melexis standard soldering information added	
8	1	uF Capacitor added on the supply line for automotive test pulses	11.03.02
	2	Chapter to automotive test pulses added	
	3	Data set added, which is stored in the devices to be delivered to a customer	
	4	Forward bias voltage vfwldt replaced by vfwdrtr	
9	1	Exchange of the pin order of CALIB and TEST	15.05.02
10	1	Chapter "Data content of parts to be delivered" redefined: values, conditions	10.07.02
	2	Application remark to the free wheel diode added: fast recovery time	
	3	Chapter "Switch frequency considerations" added	
	4	Pull down resistance on CALIB adjusted	
11	1	Application schematics adjusted according to EMI results	27.09.02
	2	Some additional application remarks have been added	
	3	iavgdrvout as parameter removed	
	4	Mechanical package drawings inserted	
	5	Application remarks for the PWM frequency added	
	6	Correction of the efficiency calculation	
	7	Relation between trimmed monoflop time and pseudo random generator jitter has been added	
	8	Por levels adjusted	
12	1	Spec of idsense adjusted	16.11.02
	2	Chapter coil driver applications adjusted: "parasitic switching", CF, RF introduced	
	3	Graph "relative luminous flux versus power supply" has been added	
	4	Calibration procedure adjusted	

	5	vdsensehyst specified as absolute voltage	
	6	ipeak removed as a specified value for the parts to be delivered	
13	1	Block diagram because of coil driving principle adjusted	27.02.03
	2	LED driver and coil driver application diagrams and -notes have been adjusted	
	3	Remark to MLX10801 applications below nominal supply voltage has been added	
	4	vfwdr, vfwdht specified	
	5	rdsdrvout, vdd, vporh, idsense, vdsensehyst respecified; vporhyst removed	
	6	Chapter "Coil inductance, EMI and selected parameter set" has been added	
	7	Coil driving principle adjusted	
	8	Influence of the pseudo random generator to the monoflop time adjusted	
	9	Trimming algorithms simplified	
14	1	Addition of Ordering Information and Disclaimer	15.03.03
	2	Layout changes	
15	1	Adjustment of the parameter set of the parts to be delivered. Definition of the coil value and sense resistor, to what this parameter set will fit.	25.03.03
16	1	vpor, isleep, vdacref, fosc respecified	29.10.03
	2	Added remark, that the comparator on RSENSE is debounced with typ. 1µs	
	3	Added remark, that high voltage on Calib will program the IC as already shown in the timing diagram	
	4	ESD respecification according to HBM	
17	1	Idsense, vfwdht respecified	29.10.03
18	1	Explanations refined, example calculation adapted	10.12.03
19	1	Typing mistakes as well as formatting errors corrected	11.02.04
	2	Working current changed to supply current in table electrical characteristics	
	3	"Johnson counter" corrected to "pseudo random generator"	
	4	Figure jitter mode corrected to true start-up behaviour and jitter	
20	1	"Preliminary" statement removed	14.05.04
	2	Melexis standard soldering information exchanged	
21	1	Specification for the package option MLX10801 in MLPD8 5x5 has been worked in, as well. For both versions there is now only one specification valid.	14.07.05
	2	Exchange of SOIC8 package drawings for better visibility	
	3	Absolute maximum ratings: 36V for max 2h added as condition, vdrvoutmax re-specified	

18. Disclaimer

Devices sold by Melexis are covered by the warranty and patent indemnification provisions appearing in its Term of Sale. Melexis makes no warranty, express, statutory, implied, or by description regarding the information set forth herein or regarding the freedom of the described devices from patent infringement. Melexis reserves the right to change specifications and prices at any time and without notice. Therefore, prior to designing this product into a system, it is necessary to check with Melexis for current information. This product is intended for use in normal commercial applications. Applications requiring extended temperature range, unusual environmental requirements, or high reliability applications, such as military, medical life-support or life-sustaining equipment are specifically not recommended without additional processing by Melexis for each application.

The information furnished by Melexis is believed to be correct and accurate. However, Melexis shall not be liable to recipient or any third party for any damages, including but not limited to personal injury, property damage, loss of profits, loss of use, interrupt of business or indirect, special incidental or consequential damages, of any kind, in connection with or arising out of the furnishing, performance or use of the technical data herein. No obligation or liability to recipient or any third party shall arise or flow out of Melexis' rendering of technical or other services.

© 2002 Melexis NV. All rights reserved.

For the latest version of this document, go to our website at:

www.melexis.com

Or for additional information contact Melexis Direct:

Europe and Japan:

Phone: +32 13 61 16 31

E-mail: sales_europe@melexis.com

All other locations:

Phone: +1 603 223 2362

E-mail: sales_usa@melexis.com

QS9000, VDA6.1 and ISO14001 Certified