

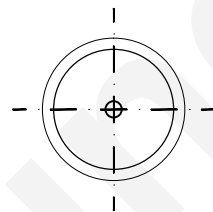

PART NO.	BASE TYPE	DESIGN VOLTS	DESIGN AMPS	MSCD	FILAMENT TYPE	AVERAGE LIFE HOURS	REVISIONS			
							REV #	DESCRIPTION	DATE	APPROVED
6430	FESTOON CAP	24.0V	0.125±20%	1.2±30%	C-8	200	1	ISSUED	05/21/2015	R.M.
							2	REVISED AMPS±TOLERANCE, MOL & DIA	06/18/2018	R.M.

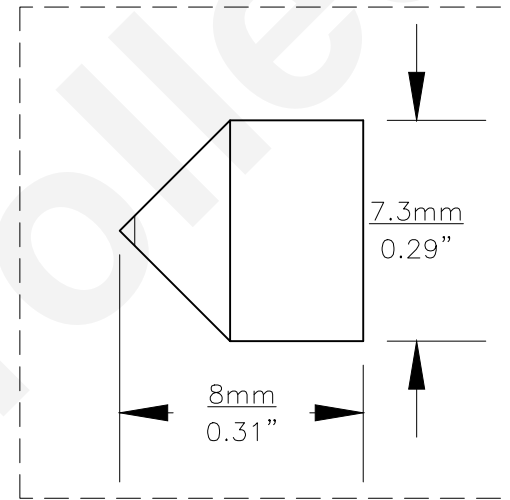
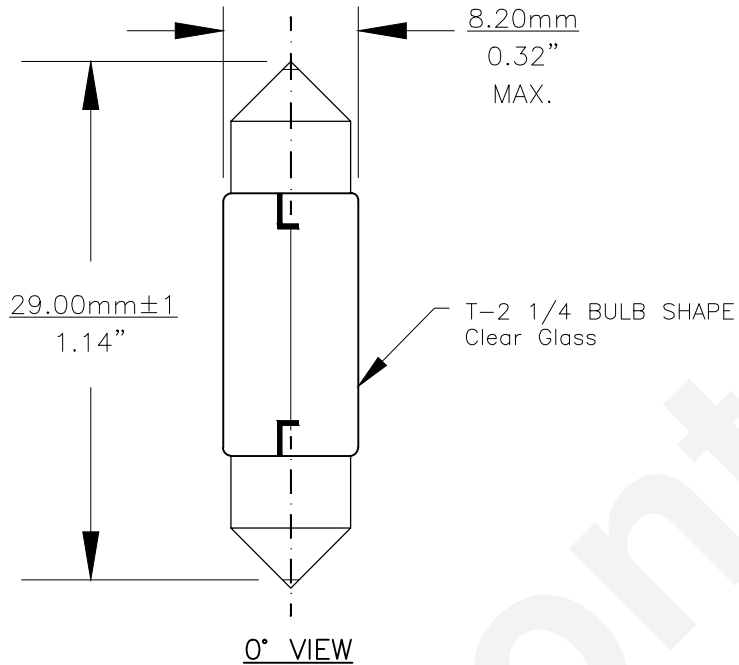

Note: Made according to SAE specifications

UNLESS OTHERWISE SPECIFIED: DIMENSIONS ARE IN INCHES TOLERANCES		CEC INDUSTRIES LTD			
DECIMALS .XX ± .05		599 BOND STREET		LINCOLNSHIRE, IL 60069	
ANGULAR .XXX ± .010		TITLE LIGHT BULB NO. 6430			
FRACTIONAL ± 1/64		DATE 05/21/2015	SIZE A	FSCM NO. 6430	REV 2
DRAWN ROSE MEDINA	CHECKED	DESIGN	SCALE	PLOT SCALE	SHEET 1 OF 1
MATERIAL		FILE 6430.pdf	DRAWING NOT TO SCALE		