

PART NUMBER	ITEM ①		ITEM ②	ITEM ③
	BODY	COLOR	CONTACT	MOUNTING NUT
105-0801-001	NYLON	WHITE	PHOSPHOR BRONZE TIN PL .0002 MIN OVER NICKEL PL .00005 MIN	BRASS NICKEL PL .0001 MIN
105-0802-001		RED		
105-0803-001		BLACK		
105-0804-001		GREEN		
105-0805-001				
105-0806-001		ORANGE		
105-0807-001		YELLOW		
105-0808-001		BROWN		
105-0809-001				
105-0810-001		BLUE		
105-0811-001				
105-0812-001		VIOLET		
105-0813-001		GRAY		
105-0814-001				
105-0815-001				
105-0816-001				
105-0817-001				
105-0818-001				
105-0819-001				
105-0820-001				

DRAWING NO.
B - 105-0801/0820-001

0 REVISIONS

REVISED AND REDRAWN. DRAWING WAS "C" SIZE 105-0801/0820-001/025 DATED 8-6-93. SPLIT INTO 2 SEPERATE DWGS. CREATED SHEET 2.

* REVISION NUMBER FOLLOWED BY AN ALPHA *
* CHARACTER INDICATES DRAWING CLARIFI- *
* CATION OR PART NUMBER ADDITION ONLY. *

18b	1-7-03	R H	R J B			10-16-03 ECN 48698
-----	--------	--------	-------------	--	--	-----------------------

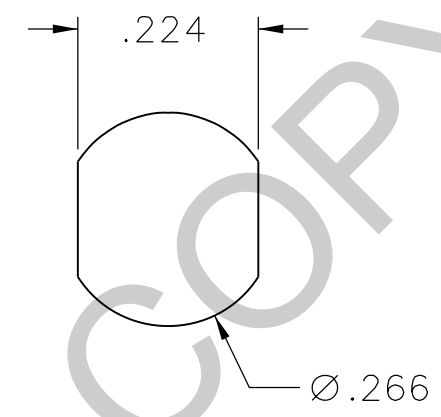

RECOMMENDED MOUNTING HOLE

2X "D" FLATS .209±.010 ACROSS FLATS

NOTES:
SPECIFICATIONS:
ELECTRICAL:
CURRENT RATING: 10 AMPS DC MINIMUM
DIELECTRIC WITHSTANDING VOLTAGE: 5700 VRMS MINIMUM AT SEA LEVEL
RECOMMENDED WORKING VOLTAGE: 2850 VRMS MAXIMUM AT SEA LEVEL
INSULATION RESISTANCE: 5000 MEGOHMS MINIMUM
CONTACT RESISTANCE: 10 MILLIOHMS MAXIMUM
CAPACITANCE: 2 PF NOMINAL
MECHANICAL:
INSERTION/WITHDRAWAL FORCE: 0.5 - 5.0 POUNDS
CONTACT RETENTION IN INSULATOR FORCE: 10 POUNDS MINIMUM
CONTACT RETENTION IN INSULATOR TORQUE: 12 IN OZ MINIMUM
INSULATOR RETENTION IN .062 PANEL FORCE: NOT APPLICABLE
INSULATOR RETENTION IN SLEEVE FORCE: NOT APPLICABLE
INSULATOR RETENTION IN .062 PANEL TORQUE: NOT APPLICABLE
PLASTIC MOUNTING THREAD STRIPPING TORQUE: 4 IN LBS MINIMUM
RESISTANCE TO TEST PROBE DAMAGE TORQUE: 2 IN LBS MINIMUM
MATING TIP PLUG DIAMETER: .080
DURABILITY: 1000 CYCLES MINIMUM
ENVIRONMENTAL:
(MEETS OR EXCEEDS THE APPLICABLE PARAGRAPH OF MIL-PRF-39024)
OPERATING TEMPERATURE: -55 DEG C TO 85 DEG C
TEMPERATURE RISE AT RATED CURRENT: 10 DEG C MAXIMUM
CORROSION: MIL-STD-1344, METHOD 1001, CONDITION B
SHOCK: MIL-STD-1344, METHOD 2004, CONDITION G
VIBRATION: MIL-STD-1344, METHOD 2005, CONDITION I
HUMIDITY: MIL-STD-1344, METHOD 1002, CONDITION B

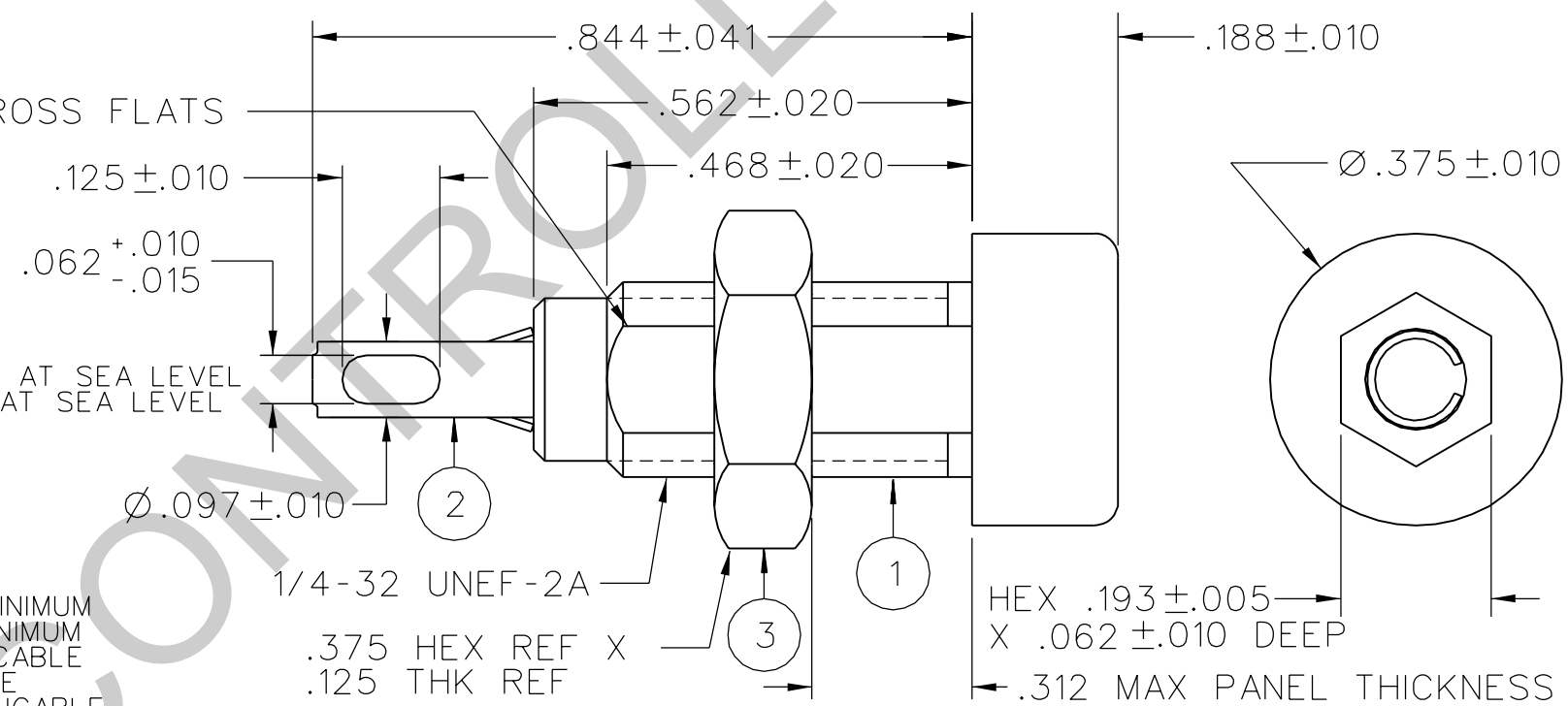

CUSTOMER DRAWING

THIS DRAWING TO BE INTERPRETED PER ASME Y 14.5M - 1994

"μSTATION"

COMPANY CONFIDENTIAL

TOLERANCE UNLESS OTHERWISE SPECIFIED		DRAWN BY	DATE
DECIMALS	mm	RJB	12-6-02
.XX		CHECKED BY	DATE
.XXX REF			
MATL		APPROVED BY	DATE
		RJB	10-16-03
FINISH		RELEASE DATE	10-16-03
		U/M	INCH
		SCALE	4:1

cinch CONNECTIVITY SOLUTIONS
a bel group

Cinch Connectivity Solutions
P.O. Box 1732
Waseca, MN 56093
1-800-247-8256

TITLE
ASSEMBLY, .080 (2.0mm) TIP JACK,
INSULATED PANEL MOUNT,
SOLDER TERMINAL

SHEET 2 OF 2
DRAWING NO. B - 105-0801/0820-001