

# International IR Rectifier

## QUIETIR 85EPF.. Series

FAST SOFT RECOVERY  
RECTIFIER DIODE

	$I_{F(RMS)} = 160 \text{ A}$
	$V_F < 1.35 \text{ V @ } 100 \text{ A}$
	$t_{tr} = 70 \text{ nsec}$
	$V_{RRM} \text{ 200 to } 600 \text{ V}$

### Major Ratings and Characteristics

Characteristics	85EPF..	Units
$I_{F(AV)}$ Rect. Conduction 50% duty Cycle @ $T_C = 85^\circ\text{C}$	85	A
$I_{F(RMS)}$	160	A
$V_{RRM}$ range (*)	200 to 600	V
$I_{FSM}$	1100	A
$V_F$ @ 100 A, $T_J = 25^\circ\text{C}$	1.35	V
$t_{tr}$ @ 1A, -100A/ $\mu\text{s}$	70	ns
$T_J$ range	-40 to 150	$^\circ\text{C}$

### Description/ Features

The 85EPF.. fast soft recovery **QUIETIR** rectifier series has been optimized for combined short reverse recovery time and low forward voltage drop.

The glass passivation ensures stable reliable operation in the most severe temperature and power cycling conditions.

Available in the new **PowIRtab™** package, this new series is suitable for a large range of applications combining excellent die to footprint ratio and sturdiness connectivity for use in high current environments.

Typical applications are both:

- Output rectification and freewheeling in inverters, choppers and converters
- Input rectifications where severe restrictions on conducted EMI should be met.

### Case Styles

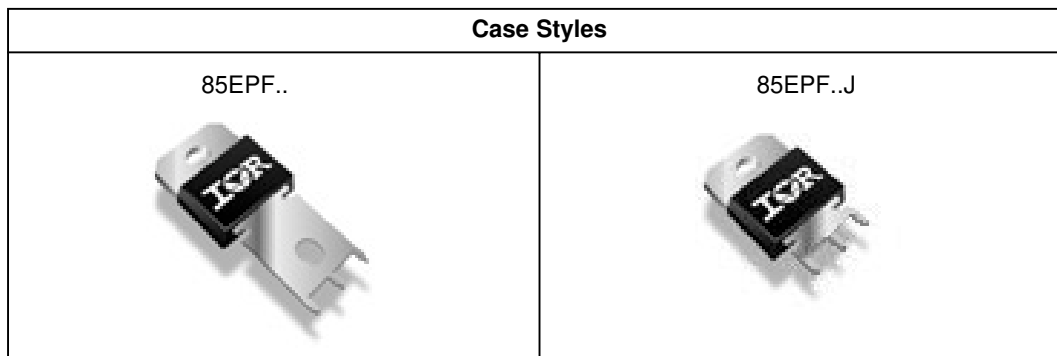

(\*) for higher voltage up to 1600V contact factory

### Voltage Ratings

Part Number	$V_{RRM}$ , maximum peak reverse voltage V	$V_{RSM}$ , maximum non repetitive peak reverse voltage V	$I_{RRM}$ 150°C mA
85EPF02	200	300	20
85EPF04	400	500	
85EPF06	600	700	

### Absolute Maximum Ratings

Parameters	85EPF..	Units	Conditions
$I_{F(AV)}$ Max. Average Forward Current	85	A	@ $T_C = 75^\circ\text{C}$ , 180° conduction half sine wave
$I_{FSM}$ Max. Peak One Cycle Non Repetitive Surge Current	1100	A	10ms Sine pulse, rated $V_{RRM}$ applied
	1250		10ms Sine pulse, no voltage reapplied
$I^2t$ Max. $I^2t$ for fusing	5000	$\text{A}^2\text{s}$	10ms Sine pulse, rated $V_{RRM}$ applied
	7000		10ms Sine pulse, no voltage reapplied
$I^2\sqrt{t}$ Max. $I^2\sqrt{t}$ for fusing	70000	$\text{A}^2\sqrt{\text{s}}$	$t = 0.1$ to 10ms, no voltage reapplied

### Electrical Specifications

Parameters	85EPF..	Units	Conditions
$V_{FM}$ Max. Forward Voltage Drop	1.3	V	@ 85A, $T_J = 25^\circ\text{C}$
$r_t$ Forward slope resistance	4.07	$\text{m}\Omega$	$T_J = 150^\circ\text{C}$
$V_{F(TO)}$ Threshold voltage	0.8	V	
$I_{RM}$ Max. Reverse Leakage Current	0.1	mA	$T_J = 25^\circ\text{C}$
	20		$T_J = 150^\circ\text{C}$

$V_R = \text{rated } V_{RRM}$

### Recovery Characteristics

Parameters	85EPF..	Units	Conditions
$t_{rr}$ Reverse Recovery Time	190	ns	$I_F @ 85\text{Apk}$ @ $25\text{A}/\mu\text{s}$
$I_{rr}$ Reverse Recovery Current	3.5	A	
$Q_{rr}$ Reverse Recovery Charge	0.6	$\mu\text{C}$	@ $25^\circ\text{C}$
S Snap Factor	0.5		

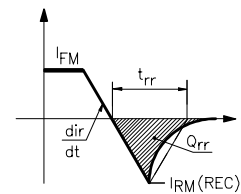

Thermal-Mechanical Specifications

Parameters	85EPF..	Units	Conditions
T <sub>J</sub> Max. Junction Temperature Range	-40 to 150	°C	
T <sub>stg</sub> Max. Storage Temperature Range	-40 to 150	°C	
R <sub>thJC</sub> Max. Thermal Resistance Junction to Case	0.35	°C/W	DC Operation
R <sub>thJA</sub> Max. Thermal Resistance Junction to Ambient	40	°C/W	
R <sub>thCS</sub> Typical Thermal Resistance, Case to Heatsink	0.2	°C/W	Mounting surface, smooth and greased
wt Approximate Weight	6(0.21)	g (oz.)	
T Mounting Torque	Min. 6(5)	Kg-cm (lbf-in)	
	Max. 12(10)		
Case Style	PowIRtab™		

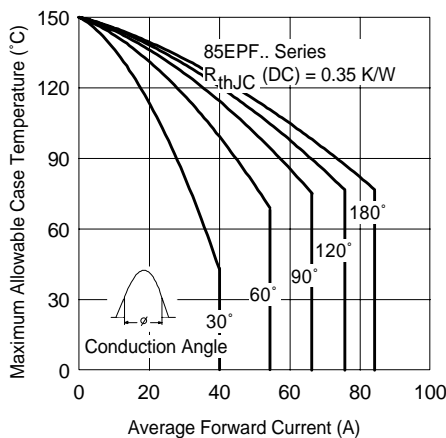

Fig. 1-Current Rating Characteristics

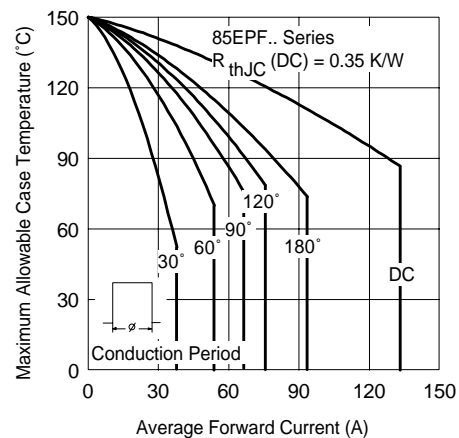

Fig. 2-Current Rating Characteristics

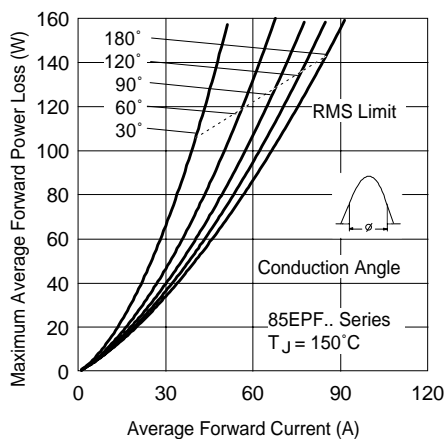

Fig. 3-Forward Power Loss Characteristics

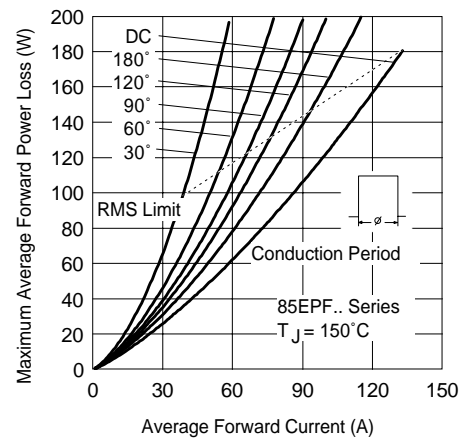

Fig. 4-Forward Power Loss Characteristics

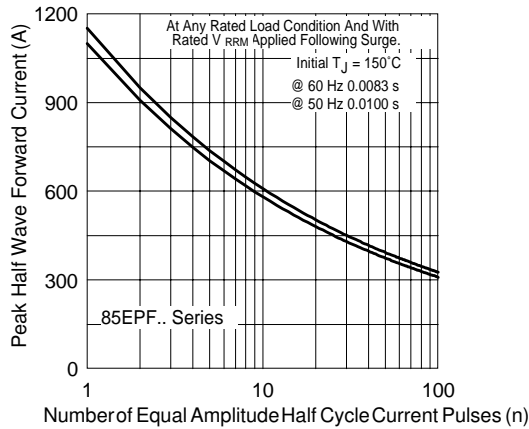

Fig. 5 - Maximum Non-Repetitive Surge Current

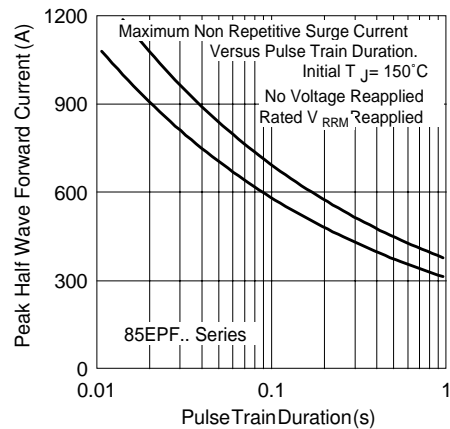

Fig. 6 - Maximum Non-Repetitive Surge Current

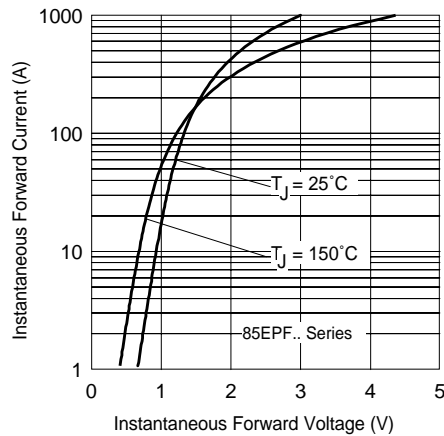

Fig. 7 - Forward Voltage Drop Characteristics

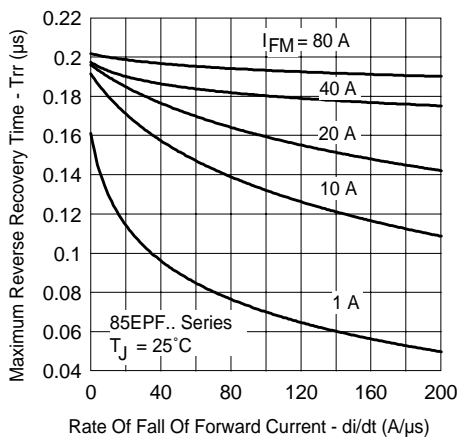

Fig. 8 - Recovery Time Characteristics,  $T_J = 25^\circ\text{C}$

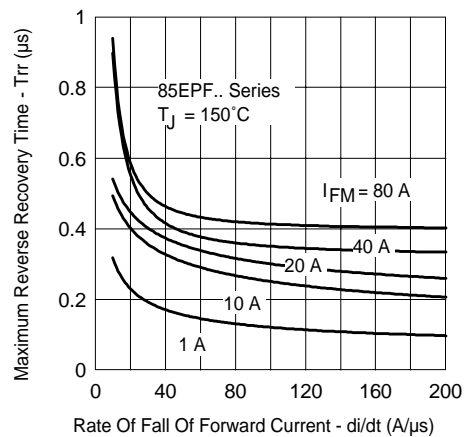

Fig. 9 - Recovery Time Characteristics,  $T_J = 150^\circ\text{C}$

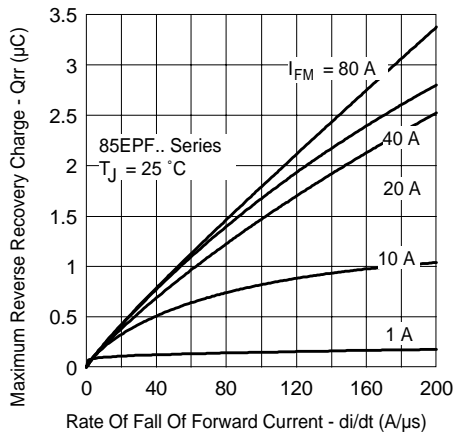

Fig. 10 - Recovery Charge Characteristics,  $T_J = 25^\circ\text{C}$

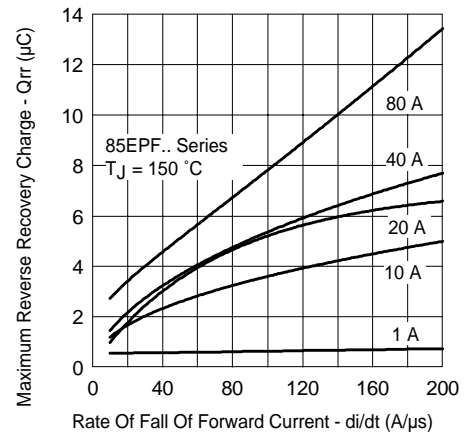

Fig. 11 - Recovery Charge Characteristics,  $T_J = 150^\circ\text{C}$

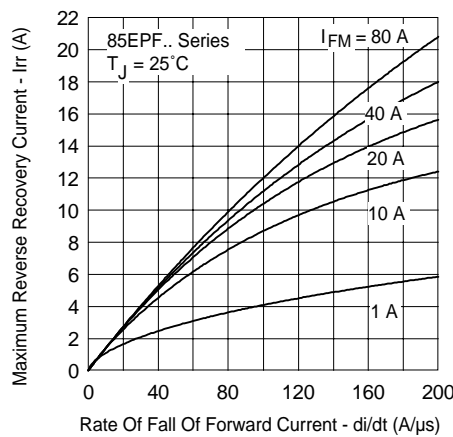

Fig. 12 - Recovery Current Characteristics,  $T_J = 25^\circ\text{C}$

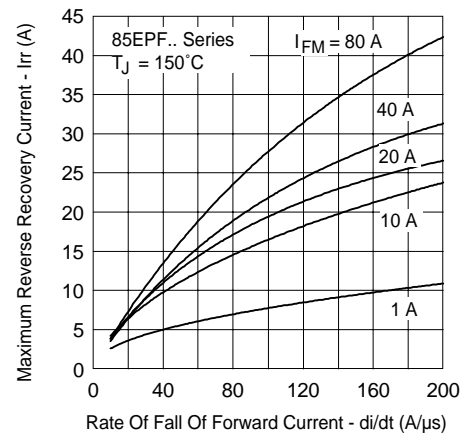

Fig. 13 - Recovery Current Characteristics,  $T_J = 150^\circ\text{C}$

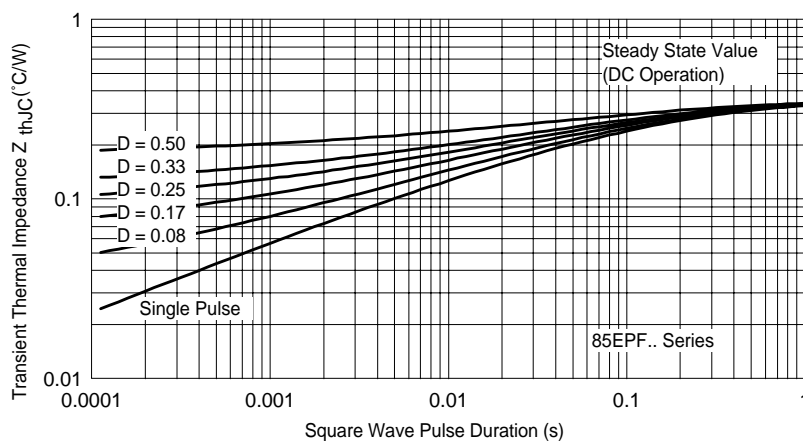
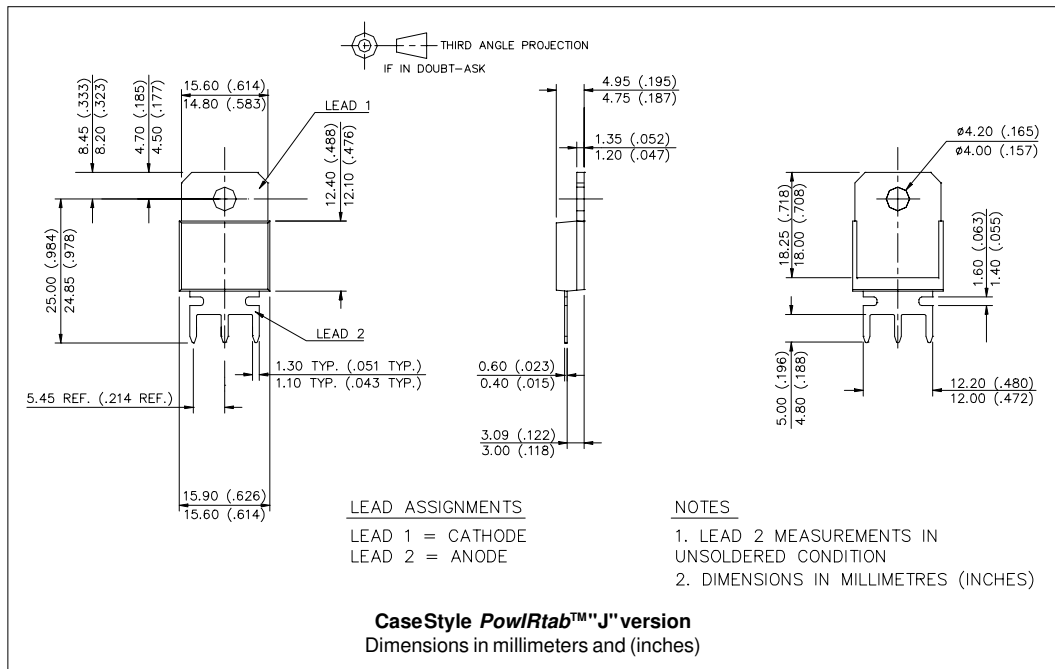
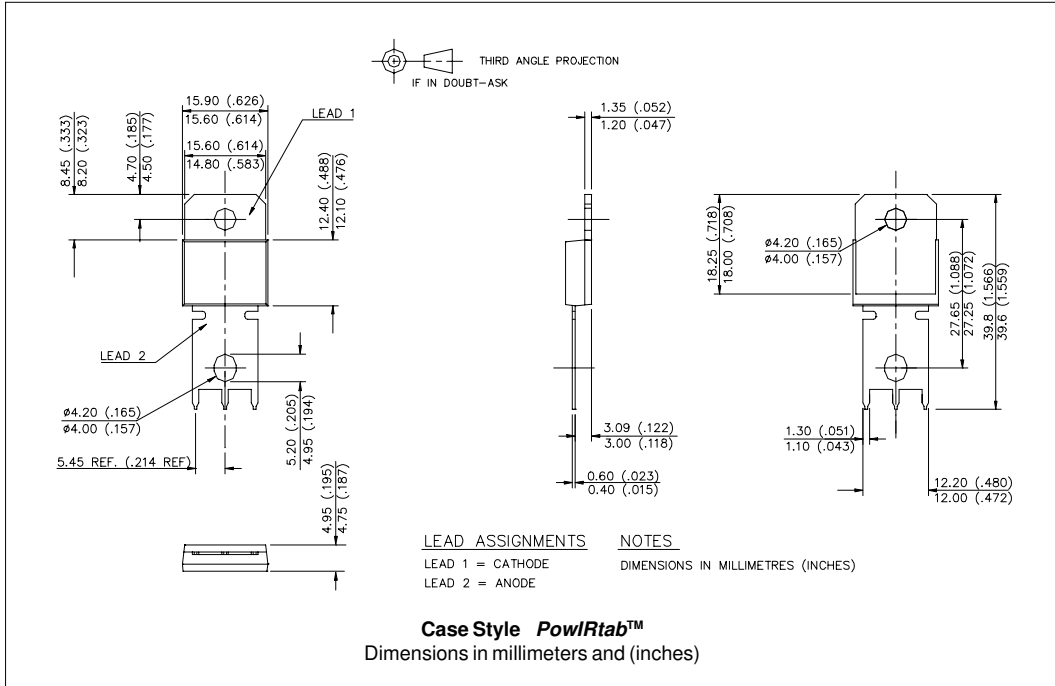
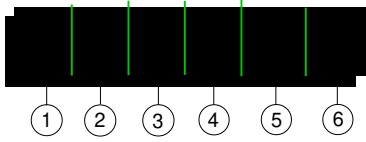

Fig. 14 - Thermal Impedance  $Z_{thJC}$  Characteristics

Outline Table



Ordering Information Table

Device Code	
	
<b>1</b>	- Current Rating
<b>2</b>	- Circuit Configuration: E = Single Diode
<b>3</b>	- Package: P = TO-247AC
<b>4</b>	- Type of Silicon: F = Fast Recovery
<b>5</b>	- Voltage code: Code x 100 = $V_{RRM}$ (*)
<b>6</b>	- none=PowIRtab™ standard
<b>65</b>	J = Short Lead Version <b>66</b>

02 = 200V
04 = 400V
06 = 600V

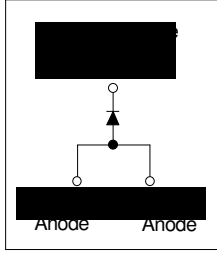

(\*) for higher voltage up to 1600V contact factory

Data and specifications subject to change without notice.  
 This product has been designed and qualified for Industrial Level.  
 Qualification Standards can be found on IR's Web site.