

COOPER CATALOG NUMBER	MATERIAL NUMBER	CONDUIT SIZE	N.P.T. FITTING SIZE	LENGTH "M"	DIAMETER "A" REF.	LENGTH "B" REF.	LENGTH "C" REF.	LENGTH "D" REF.	PRODUCT SELECTION NUMBER	UL LISTED	CSA APRVD
36442	1300960057	3/8"	1/2"	3.875±0.500 / 98.43±12.70	1.0 / 25	1.13 / 28.7	0.63 / 16.0	0.88 / 22.4	STB038P-45	YES	YES
36390	1300960044	1/2"	1/2"	4.625±0.500 / 117.48±12.70	1.2 / 30	1.25 / 31.8	0.63 / 16.0	0.88 / 22.4	STB050P-45		
36392	1300960046	1"	1"	7.000±0.500 / 177.80±12.70	1.7 / 43	1.81 / 45.9	0.75 / 19.1	1.38 / 35.1	STB100P-45		
36393	1300960047	1-1/4"	1-1/4"	8.125±1.000 / 206.38±25.40	2.0 / 51	2.31 / 58.7	0.63 / 16.0	1.63 / 41.4	STB125P-45		
36394	1300960048	1-1/2"	1-1/2"	9.250±1.000 / 234.95±25.40	2.5 / 64	2.63 / 66.8	0.63 / 16.0	1.81 / 45.9	STB150P-45		
37036	-----	2-1/2"	2-1/2"	11.250±1.000 / 285.75±25.40	3.6 / 91	3.94 / 100.1	1.06 / 26.9	3.56 / 90.4	STB250P-45		
37037	1300960068	3"	3"	14.750±1.500 / 374.65±38.10	4.3 / 109	4.38 / 111.3	1.19 / 30.2	4.31 / 109.5	STB300P-45		
37038	-----	4"	4"	16.250±1.500 / 412.75±38.10	5.4 / 137	5.50 / 139.7	1.25 / 31.8	4.63 / 117.6	STB400P-45		

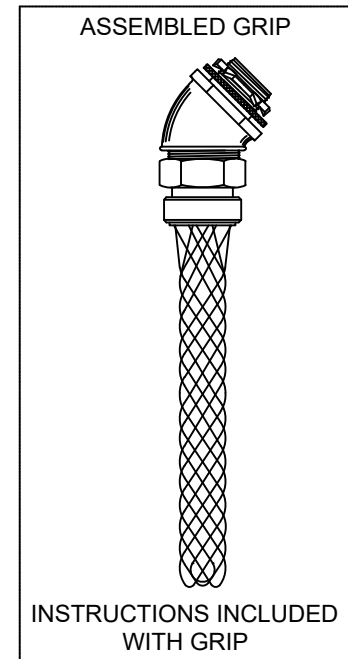
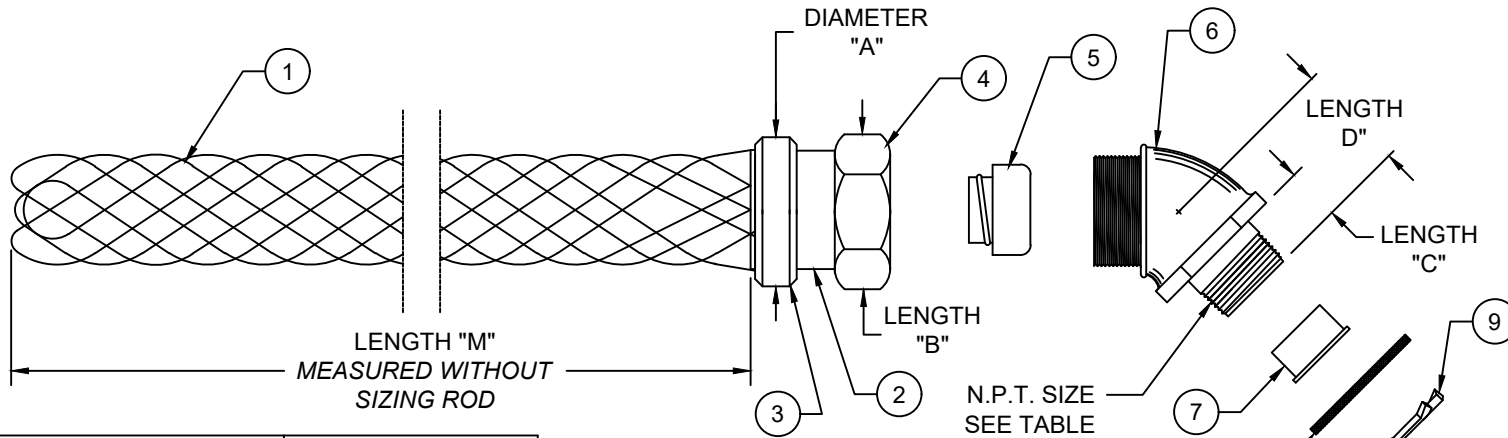

ITEM	DESCRIPTION	MATERIAL
1	WIRE MESH	STAINLESS STEEL
2	INNER RING	ZINC PLATED STEEL
3	OUTER RING	ALUMINUM
4	COMPRESSION NUT	ZINC PLATED STEEL OR MALLEABLE IRON
5	FERRULE	ZINC PLATED STEEL OR ALUMINUM
6	THREADED BODY	ZINC PLATED STEEL OR MALLEABLE IRON
7	THROAT INSULATION	PLASTIC
8	GASKET	NEOPRENE
9	LOCK NUT	ZINC PLATED STEEL

FUNCTIONAL SYMBOLS $\nabla_A = 0$ $\nabla_C = 0$ $\nabla_F = 0$	DIMENSION UNITS INCH/MM		SCALE NTS	CURRENT REV DESC: OBSOLETE PART NUMBER AS PER PCN#510808																				
	GENERAL TOLERANCES (UNLESS SPECIFIED)			EC NO: 736640																				
	<table border="1"> <tr> <th></th> <th>mm</th> <th>INCH</th> </tr> <tr> <td>4 PLACES</td> <td>± ----</td> <td>± ----</td> </tr> <tr> <td>3 PLACES</td> <td>± ----</td> <td>± 0.005</td> </tr> <tr> <td>2 PLACES</td> <td>± 0.13</td> <td>± 0.01</td> </tr> <tr> <td>1 PLACE</td> <td>± 0.25</td> <td>± 0.02</td> </tr> <tr> <td>0 PLACES</td> <td>± ----</td> <td>± ----</td> </tr> </table>				mm	INCH	4 PLACES	± ----	± ----	3 PLACES	± ----	± 0.005	2 PLACES	± 0.13	± 0.01	1 PLACE	± 0.25	± 0.02	0 PLACES	± ----	± ----	DRWN: SUGEEB 2022/12/21 CHK'D: LIKITV 2023/02/14 APPR: GGA 2023/02/16		
		mm	INCH																					
4 PLACES	± ----	± ----																						
3 PLACES	± ----	± 0.005																						
2 PLACES	± 0.13	± 0.01																						
1 PLACE	± 0.25	± 0.02																						
0 PLACES	± ----	± ----																						
DIVISIONAL SYMBOLS			INITIAL REVISION: DRWN: HRUIZ01 2014/09/23 APPR: JFMURPHY 2015/04/27																					
DRAFT WHERE APPLICABLE MUST REMAIN WITHIN DIMENSIONS			THIRD ANGLE PROJECTION	DRAWING A-SIZE	SERIES 130096																			

STRAIN RELIEF
LIQUID TIGHT CONDUIT 45 DEGREE-MALE

PRODUCT CUSTOMER DRAWING

DOCUMENT NUMBER	DOC TYPE	DOC PART	REVISION
SD-130096-102	PSD	001	A1

MATERIAL NUMBER	CUSTOMER	SHEET NUMBER
SEE TABLE	GENERAL MARKET	1 OF 1