

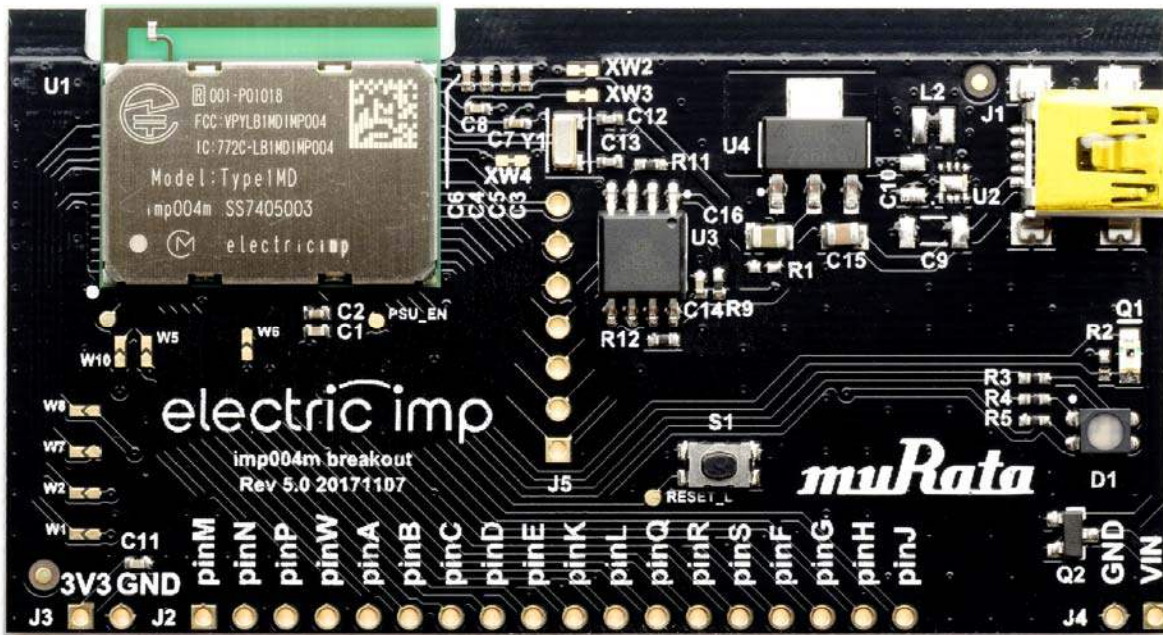

imp004m Breakout

The imp004m breakout board provides the imp004m module with a power supply, GPIO breakout, an optional 32kHz crystal and required SPI flash.



impCloud Support Options

The imp004m Breakout Board can be purchased in pre-assembled form. There are two versions, each compatible with a specific Electric Imp impCloud™:

- [imp004m Breakout Board for AWS impCloud](#)
- [imp004m Breakout Board for Azure impCloud](#)

Set Up

To set up an imp004m Breakout Board, please see [this page](#).

Pinout Chart

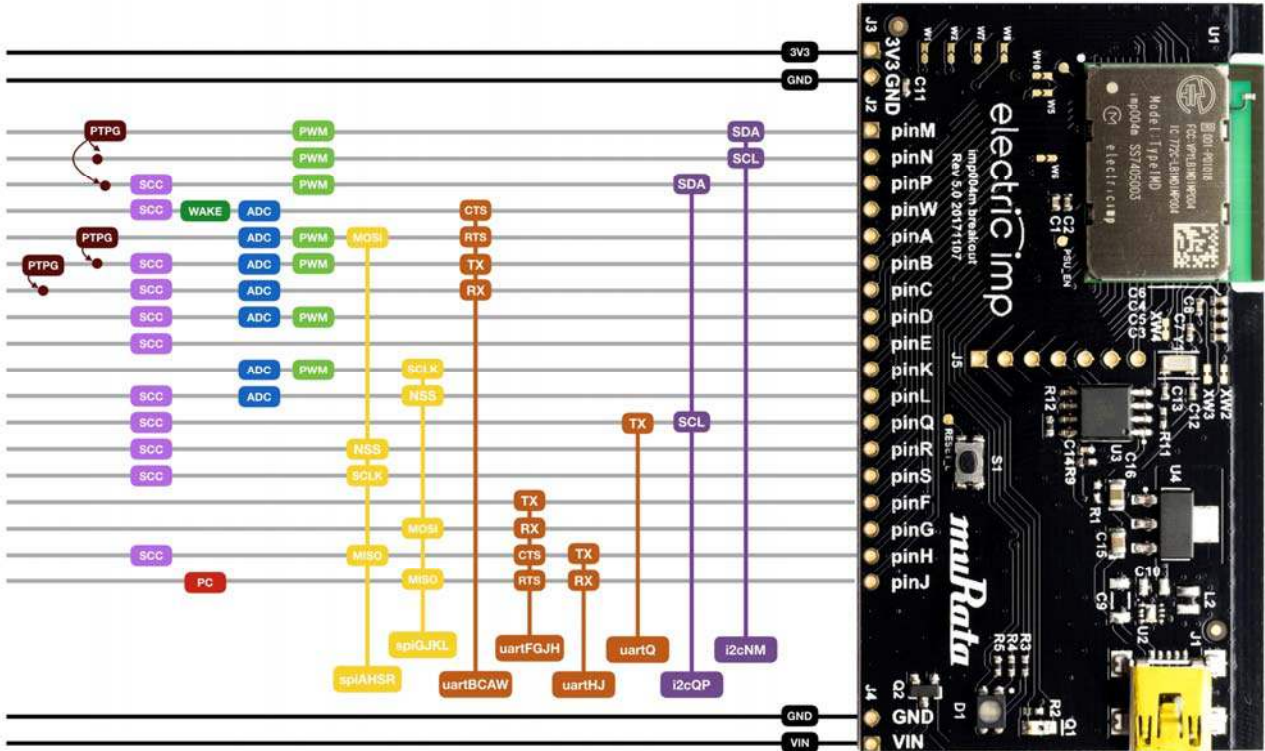

electric imp™
imp004m Breakout Board

State-change Callback	SPI	POWER
Pulse Counter	UART	ADC
Wake-up Pin	I2C	PWM
Pin-triggered Pulse Generator		

Click for larger version

Hardware Details

Bluetooth LE

Note Bluetooth LE requires impOS 38 or above.

The imp004m’s WiFi chip is the [Cypress Semiconductor CYW43438 communication chip](#), which also supports Bluetooth 4.1. The CYW43438 Bluetooth unit is not connected to the imp004m’s MCU, but the CYW43438’s Bluetooth-specific pins are brought out to the imp004m pin-out to make them accessible to hardware designers who wish to make use of the module’s Bluetooth features in their products. They are connected to the imp004m Audio Kit as follows:

imp004m GPIO Pin CYW43438 Pin		Notes
hardware.pinE	LPO_IN	Drive low
hardware.pinF	BT_UART_RX	Access via hardware.uartFGJH
hardware.pinG	BT_UART_TX	Access via hardware.uartFGJH
hardware.pinJ	BT_REG_ON	Drive high to enable the Bluetooth LE sub-system

The following code example will enable the Bluetooth LE on the imp004m Audio Kit:

```
// Set up Bluetooth on the imp004m Audio Kit
// Alias the relevant UART bus, LPO and power-on pins
bt_uart <- hardware.uartFGJH;
bt_lpo_in <- hardware.pinE;
bt_reg_on <- hardware.pinJ;

// Boot up Bluetooth: ground LPO_IN and set BT_REG_ON to High
bt_lpo_in.configure(DIGITAL_OUT, 0);
bt_reg_on.configure(DIGITAL_OUT, 1);
```

After making use of Bluetooth, you should set CYW43438 pins BT_REG_ON and LPO_IN low and if you wish to power down and fully disable the imp004m's Bluetooth sub-system.

- For more detailed information on Bluetooth LE usage with the Audio Kit's imp004m module, please see [this guide](#).

Programming Resources

- [imp004m Pin Mux](#)
- [imp004m Datasheet](#)
- [Working with Audio on the imp004m](#)

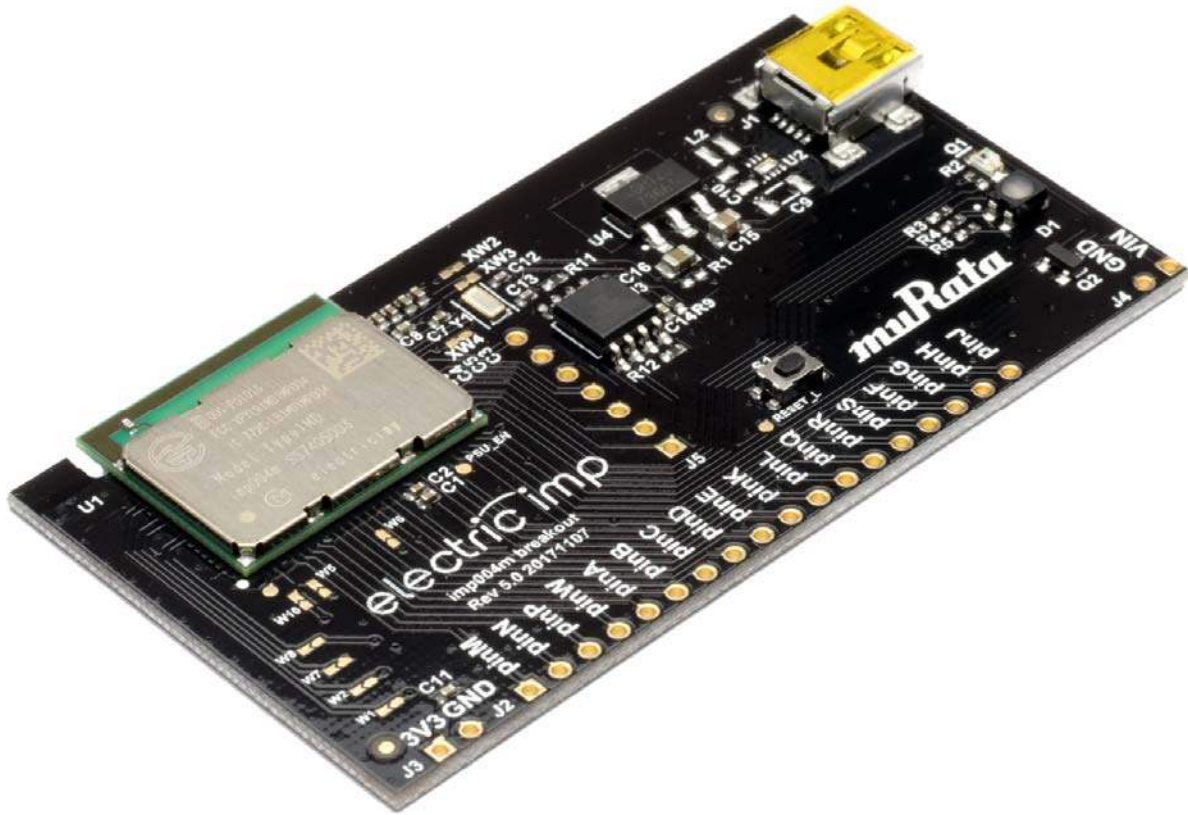

Hardware Design Files (Rev 5.0)

- Schematics
- Gerber Files
- Bill of Materials
- Altium Source Files

<https://developer.electricimp.com/hardware/resources/reference-designs/imp004mbreakout> 4-27-18