

4

3

2

1

THIS DRAWING IS UNPUBLISHED.

RELEASED FOR PUBLICATION

© COPYRIGHT

ALL RIGHTS RESERVED.

LOC DIST

REVISIONS

P	LTR	DESCRIPTION	DATE	DWN	APVD
	B2	ECR-13-002998	16FEB2013	XZ	SX

REPLACED BY OCEAN STYLE APPLICATOR PART NUMBER 2151168-1

FOR REPLACEMENT PARTS FOR APPLICATOR 1385896
REFER TO ADDITIONAL PAGE(S). SPARE PARTS KIT (IF LISTED)
WILL REMAIN AVAILABLE.

THE REPLACEMENT OCEAN STYLE APPLICATOR HAS THE
SAME TERMINATOR/PRESS INTERFACE AS APPLICATOR
1385896

Dimensioning and tolerancing per ASME Y14.5M-2009

A

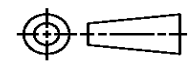
THIS DRAWING IS A CONTROLLED DOCUMENT.		DWN X. ZHAO	 TE Connectivity			
DIMENSIONS:		CHK S. XI				
TOLERANCES UNLESS OTHERWISE SPECIFIED:		APVD S. XI	NAME			
		PRODUCT SPEC	SIDE FEED HDM APPLICATOR			
		APPLICATION SPEC				
MATERIAL	FINISH	WEIGHT	SIZE A3	CAGE CODE	DRAWING NO C-1385896	RESTRICTED TO
		SCALE		SHEET 1 OF 2		REV B2

1470-19 (3/11)

Pr o/ENGINEER DRAWING

Dimensioning and tolerancing per ASME Y14.5M-2009

THIS DRAWING IS UNPUBLISHED. RELEASED FOR PUBLICATION. BY TYCO ELECTRONICS CORPORATION. ALL RIGHTS RESERVED.

Table with 3 columns: PART NUMBER, REV, FIRST USED. Rows include 1385896-1, 1385896-2, 1385896-3, 7-1385896-7.

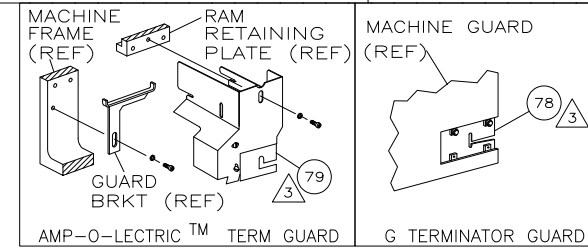

Terminal Name: .070 Series Receptacle. Table with columns: PIN, SOCKET, AMP CRIMP SPECS, CRIMP HEIGHT, WIRE SIZE, CRIMP SIZE, TYPE, RANGE, WIRE, INSUL.

Revisions table with columns: REVISIONS, DESCRIPTION, DATE, DWN, APD. Includes revisions for LEADMAKER, BENCH MODEL K, BENCH MODEL G, and SPARE PARTS KIT.

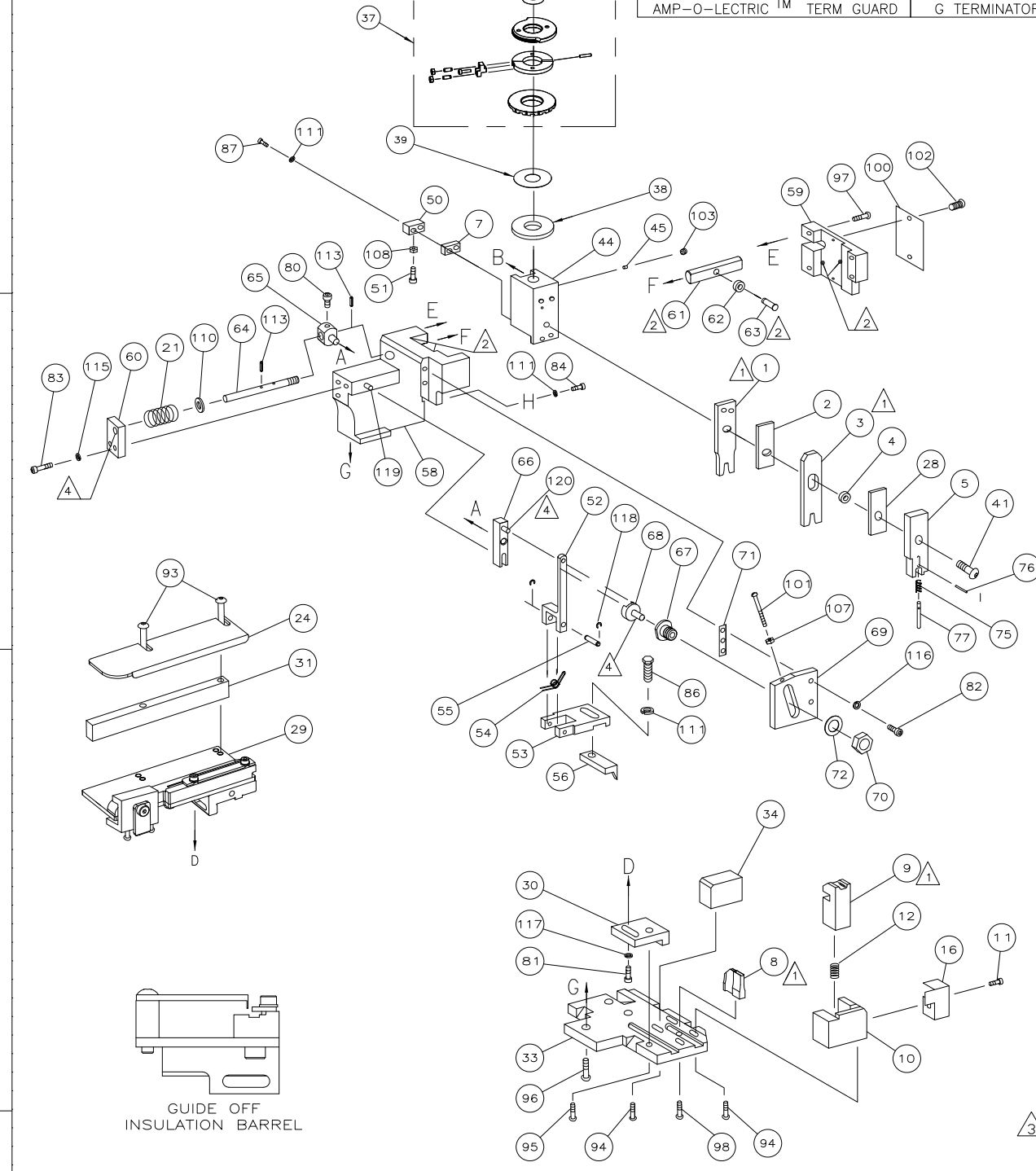

Parts List table with columns: QTY, REF, PART NO, DESCRIPTION, ITEM NO. Lists various components like PIN, DOWEL, WASHER, NUT, SPRING, and STRIPPER.

Continuation of the Parts List table, listing components like LEVER, BUMPER, SPACER, CAM, PLUG, RAM, BOLT, SHIM, SPACER, STRIPPER, GUIDE, ANVIL, SPRING, STRIPPER, CRIMPER, and SPACER.

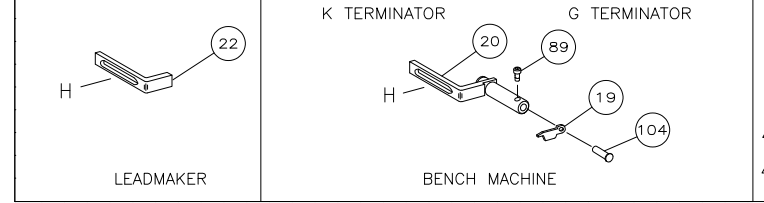
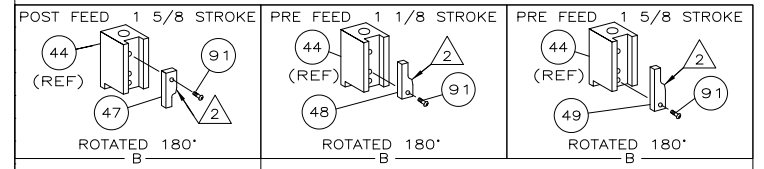

- 1 RECOMMENDED SPARE PARTS.
2 GREASE LIGHTLY.
3 GUARD MUST BE IN PLACE WHEN OPERATING APPLICATOR IN A BENCH MACHINE.
4 LUBRICATE DAILY USING NO. 20 MACHINE OIL.
5. ITEMS WITH QTY OF REF SPECIFIED (EXCEPT ITEMS 78 AND 79) ARE USED ON ITEM 46.
6 LUBRICATE REQUIRED WITH GOLD PLATED TERMINALS
7 ITEM 29 MUST BE ADJUSTED TO AQUIRE PROPER CUT-OFF TABS

* WARNING: ON INSTALLATION, SET WIRE DISC TO LARGEST WIRE SIZE SETTING. USE OF SETTINGS BELOW MIN REQUIRED CRIMP HEIGHT SETTING WILL CAUSE DAMAGE TO CRIMP TOOLING.

Technical drawing information including dimensions, tolerances, material, finish, weight, and customer drawing details.