

DESIGNED & DIMENSIONED
IN INCHES[MILLIMETERS]

DO NOT
SCALE FROM
THIS PRINT

PRF04-P-C-EP-290-SS

SERIES
-04: TNCA

GENDER
-P: PLUG

TYPE
-C: CABLE

TERMINATION
-S: SOLDER CLAMP

ORIENTATION
-S: STRAIGHT

CABLE TYPE
-290: SEMFLEX LA290

FINISH
-EP: 50µ" EXTRA HEAVY GOLD
CENTER CONTACT, PASSIVATED
OUTER CONTACT

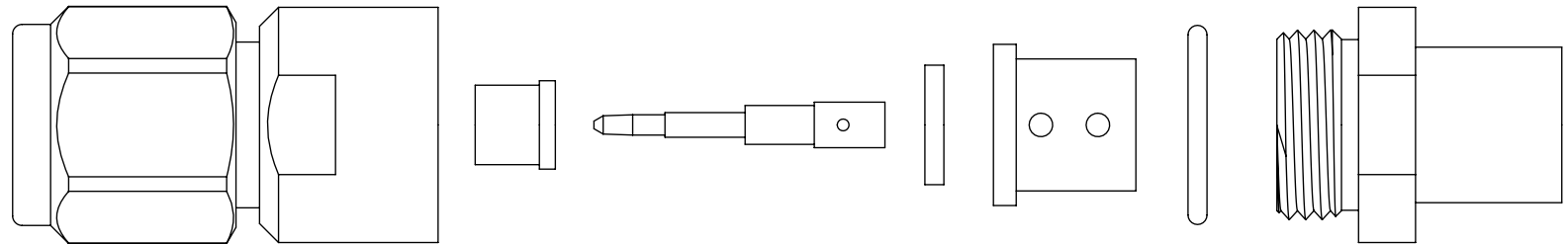
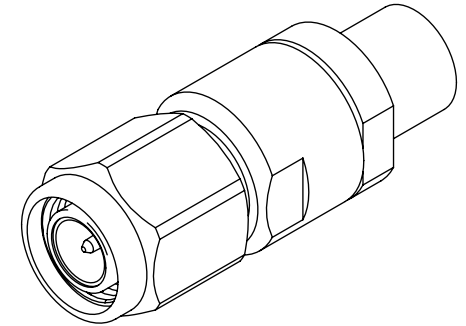
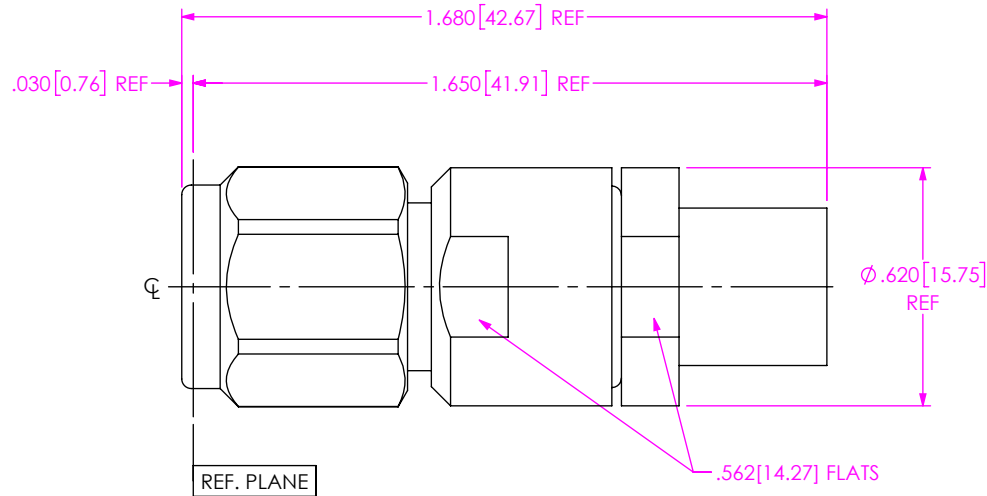

EXPLODED VIEW
NOT TO SCALE
(FOR CLARITY ONLY)

NOTES:

- MATERIAL:
BODY, COUPLING NUT & CLAMP NUT: STAINLESS STEEL.
PIN & LOCK RING: BERYLLIUM COPPER.
SOLDER FERRULE: BRASS.
GASKET & O-RING: SILICONE RUBBER.
INSULATOR: TEFLON.
BEAD: ULTEM 1000.
- FINISH:
BODY, COUPLING NUT & CLAMP NUT: PASSIVATED.
PIN & SOLDER FERRULE: GOLD OVER NICKEL PLATE,
50 µIN MIN GOLD OVER 50 µIN MIN NICKEL.
- PCI P/N: 3287.

UNLESS OTHERWISE SPECIFIED,
DIMENSIONS ARE IN INCHES.
TOLERANCES ARE:
DECIMALS ANGLES
.XX: ±.01 [0.3] 1°
.XXX: ±.005 [0.13]
.XXXX: ±.0005 [0.013]

PROPRIETARY NOTE
* THIS DOCUMENT CONTAINS CONFIDENTIAL AND PROPRIETARY INFORMATION AND ALL DESIGN, MANUFACTURING, REPRODUCTION, USE, PATENT RIGHTS AND SALES RIGHTS ARE EXPRESSLY RESERVED BY SAMTEC, INC. THIS DOCUMENT SHALL NOT BE DISCLOSED, IN WHOLE OR PART, TO ANY UNAUTHORIZED PERSON OR ENTITY NOR REPRODUCED, TRANSFERRED OR INCORPORATED IN ANY OTHER PROJECT IN ANY MANNER WITHOUT THE EXPRESS WRITTEN CONSENT OF SAMTEC, INC.



520 PARK EAST BLVD, NEW ALBANY, IN 47150
PHONE: 812-944-6733 FAX: 812-948-5047
e-Mail: info@SAMTEC.com code 55322

DO NOT SCALE DRAWING

SHEET SCALE: 2:1

DESCRIPTION: TNCA PLUG, SOLDER CLAMP FOR SEMFLEX LA290 CABLE

DWG. NO. PRF04-P-C-EP-290-SS

BY: CHRISTIAN S. 05/08/2019 SHEET 1 OF 2

1. TRIM CABLE AS SHOWN.

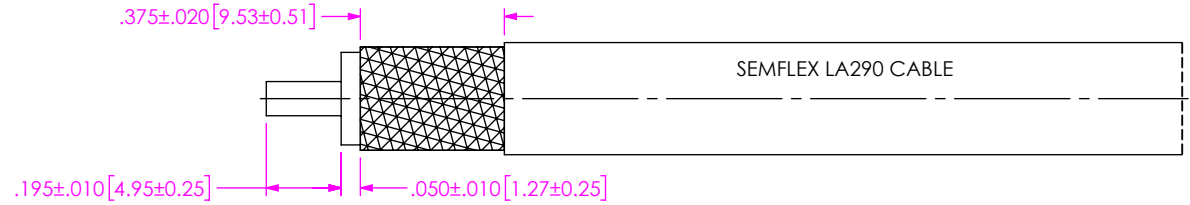

IN-PROCESS 1

2A. SLIDE CLAMP NUT OVER CABLE AS SHOWN.

2B. INSERT CABLE INTO SOLDER FERRULE UNTIL CABLE DIELECTRIC IS FLUSH WITH FACE OF FERRULE. THEN SOLDER BOTH CABLE BRAIDS WHERE SHOWN.

2C. SLIDE DIELECTRIC STOP OVER CABLE CENTER CONDUCTOR AND SOLDER CONTACT FLUSH AGAINST STOP TO DIMENSION SHOWN.

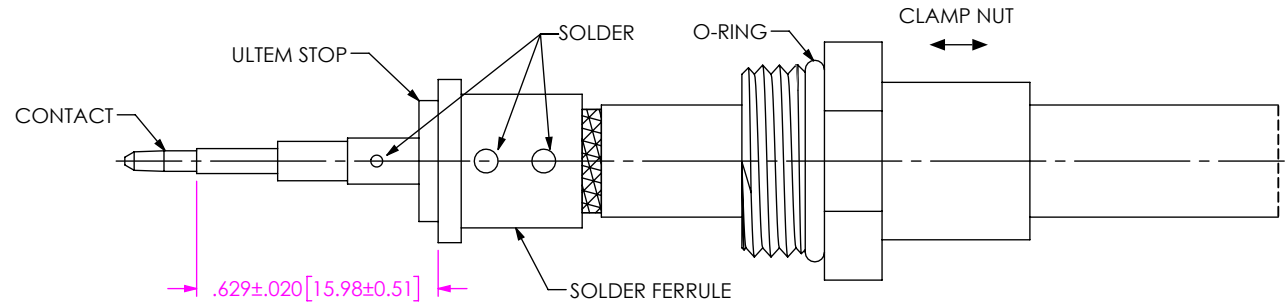

IN-PROCESS 2

3A. INSERT FORWARD INSULATOR INTO CONNECTOR IN ORIENTATION SHOWN.

3B. INSERT CABLE/CONTACT SUB-ASSEMBLY INTO CONNECTOR UNTIL SEATED AND TIGHTEN CLAMP NUT TO 35-45 IN-LBS.

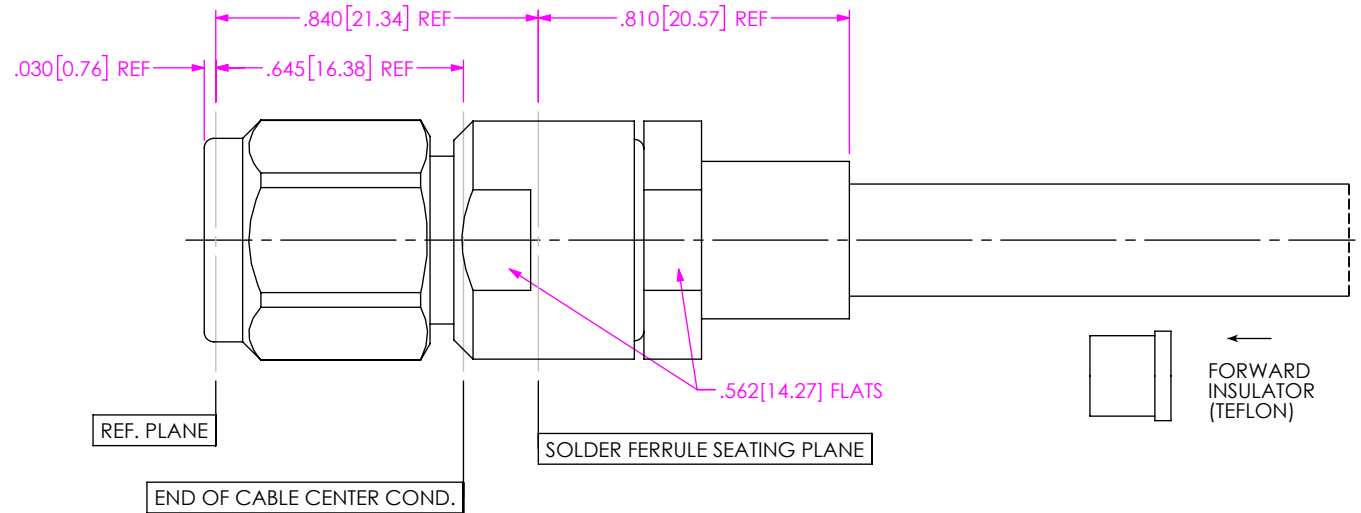

IN-PROCESS 3

<p>DO NOT SCALE DRAWING</p> <p>SHEET SCALE: 2:1</p>	<p>PROPRIETARY NOTE</p> <p>THIS DOCUMENT CONTAINS CONFIDENTIAL AND PROPRIETARY INFORMATION AND ALL DESIGN, MANUFACTURING, REPRODUCTION, USE, PATENT RIGHTS AND SALES RIGHTS ARE EXPRESSLY RESERVED BY SAMTEC, INC. THIS DOCUMENT SHALL NOT BE DISCLOSED, IN WHOLE OR PART, TO ANY UNAUTHORIZED PERSON OR ENTITY NOR REPRODUCED, TRANSFERRED OR INCORPORATED IN ANY OTHER PROJECT IN ANY MANNER WITHOUT THE EXPRESS WRITTEN CONSENT OF SAMTEC, INC.</p>	<p>samtec</p> <p>520 PARK EAST BLVD, NEW ALBANY, IN 47150 PHONE: 812-944-6733 FAX: 812-948-5047 e-Mail: info@SAMTEC.com code 55322</p>
	<p>DESCRIPTION: TNCA PLUG, SOLDER CLAMP FOR SEMFLEX LA290 CABLE</p>	
	<p>DWG. NO. PRF04-P-C-EP-290-SS</p>	
<p>BY: CHRISTIAN S. 05/08/2019 SHEET 2 OF 2</p>		