

**DESIGNED & DIMENSIONED
IN MILLIMETERS[INCHES]**

TABLE 1

No OF POS	N	N-1
-02	04	03
-03	06	05
-04	08	07
-05	10	09
-06	12	11
-07	14	13
-08	16	15
-09	18	17
-10	20	19
-11	22	21
-12	24	23
-13	26	25
-14	28	27
-15	30	29
-16	32	31
-17	34	33
-18	36	35
-19	38	37
-20	40	39

DO NOT
SCALE FROM
THIS PRINT

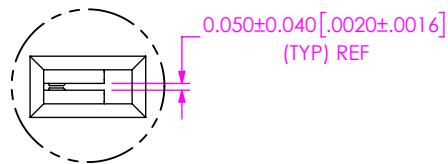

DETAIL 'A'
SCALE 18:1

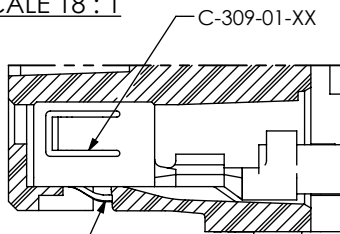

DETAIL 'B'
SCALE 8:1

SEE NOTE 6

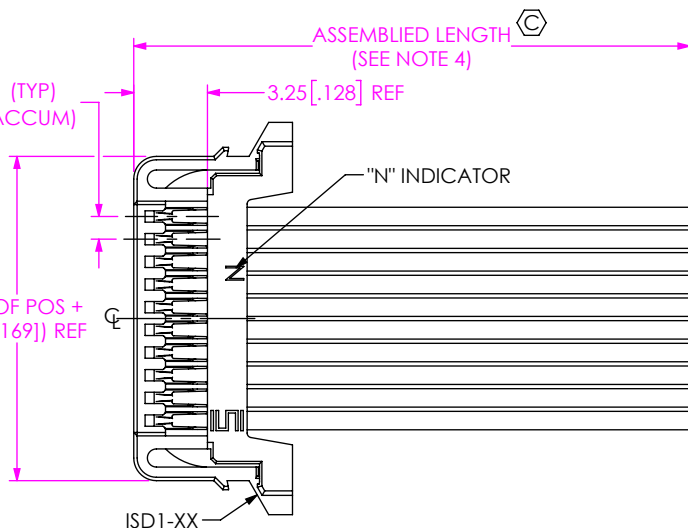
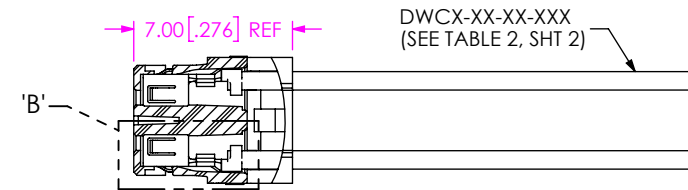
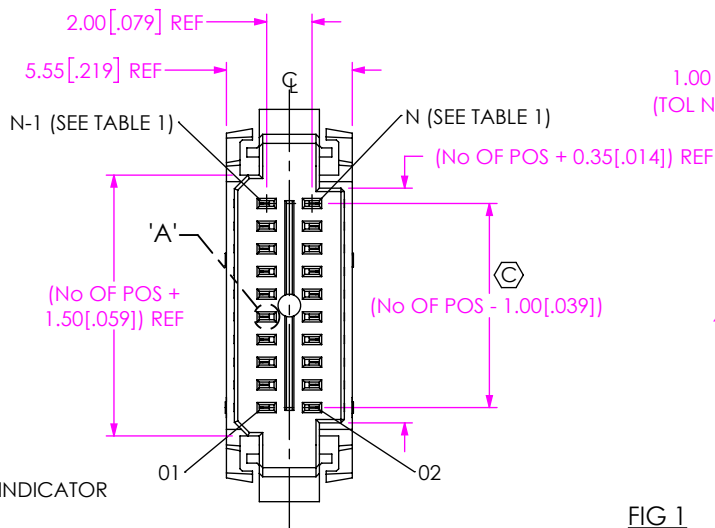
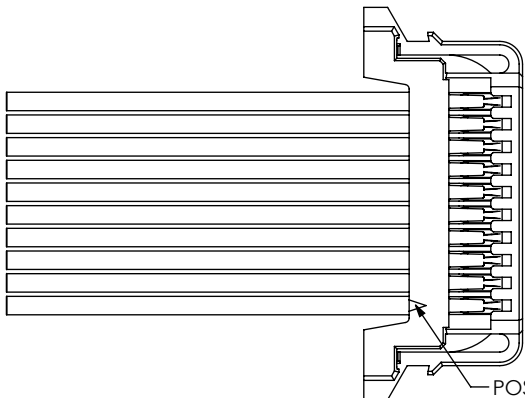

S1SDX-XX-XXX-XX-XX.XX-LX

FEP CABLE OPTION
-T: FEP INSULATION
LEAVE BLANK FOR PVC
(SEE NOTE 8)

No OF POSITIONS (PER ROW)
-02 THRU -20

WIRE GAUGE (AWG)
-28, -30

COLOR CODE
-C COLOR CODE WIRE
(SEE TABLE 4, SHT 2)
LEAVE BLANK FOR STANDARD WIRE
(SEE TABLE 2, SHT 2)
(NOT AVAILABLE FOR TEFLON OPTION,
TEFLON CABLE ONLY AVAILABLE IN BLUE)

PINOUT
(LEAVE BLANK FOR SINGLE END ASSEMBLY)
-1: "N" INDICATOR DOWN, CROSSED
PIN 1 TO PIN 1 (SEE FIG 2, SHT 2)
-2: "N" INDICATOR DOWN, STRAIGHT
PIN 1 TO PIN 2 (SEE FIG 3, SHT 2)
-3: "N" INDICATOR UP, CROSSED
PIN 1 TO PIN N (SEE FIG 4, SHT 3)
-4: "N" INDICATOR UP, STRAIGHT
PIN 1 TO PIN N-1 (SEE FIG 5, SHT 3)

LATCH OPTION
-L: PLASTIC LATCH

ASSEMBLED LENGTH
(SPECIFY IN INCHES) 01.80 IN MINIMUM

PLATING SPECIFICATION
-T: BRIGHT ACID TIN TIN CONTACT AND TAIL
(FOR EXISTING CUSTOMER ONLY)
-GF: 3µ" GOLD CONTACT AND TAIL

FIG 1

S1SD-10-XXX-XX-XX.XX-L SHOWN

NOTES:

1. Ⓢ REPRESENTS A CRITICAL DIMENSION.
2. MINIMUM PUSHOUT FORCE: SIGNAL: 4.445N[1.0 LB].
3. PARTS TO BE PACKAGED IN BAG.
4. FOR ASSEMBLED LENGTHS LESS THAN 12.0[305], TOLERANCE SHALL BE ± 3.18[.125], FOR OTHER LENGTHS, TOLERANCE SHALL BE ± 2%.
5. REFER TO CRIMP SPECIFICATIONS FOR CRIMP AND STRIP DIMENSIONS, TOLERANCES, TOOLING, AND ITS REQUIREMENTS.
6. CONTACT MUST BE INSERTED UNTIL RETENTION FEATURE LOCKS IN PLACE.
7. ALL FINISHED GOODS ARE TO BE ELECTRICALLY TESTED INCLUDING HI-POT TEST AT 1000 VOLTS DC. AFTER FINAL ELECTRICAL TEST, MARK EACH ASSEMBLY PER INSTRUCTIONS REFERENCED IN CO-{AD-ID}-WI-3092-M
8. ASSEMBLIES USING THE FEP OPTION ARE FOR CRIMP APPLICATIONS ONLY.
9. NOTE DELETED.
10. CUT LENGTH IS ASSEMBLY LENGTH MINUS OVERALL LENGTH SUBTRACTOR.
11. TABLE 3 IS DELETED AND REPLACED WITH EQUATIONS.

UNLESS OTHERWISE SPECIFIED,
DIMENSIONS ARE IN MILLIMETERS.
TOLERANCES ARE:
DECIMALS ANGLES
X.X: ±0.3 [01] 2°
X.XX: ±0.13 [005]
X.XXX: ±0.051 [0020]

PROPRIETARY NOTE

THIS DOCUMENT CONTAINS CONFIDENTIAL AND PROPRIETARY INFORMATION AND ALL DESIGN, MANUFACTURING, REPRODUCTION, USE, PATENT RIGHTS AND SALES RIGHTS ARE EXPRESSLY RESERVED BY SAMTEC, INC. THIS DOCUMENT SHALL NOT BE DISCLOSED, IN WHOLE OR PART, TO ANY UNAUTHORIZED PERSON OR ENTITY NOR REPRODUCED, TRANSFERRED OR INCORPORATED IN ANY OTHER PROJECT IN ANY MANNER WITHOUT THE EXPRESS WRITTEN CONSENT OF SAMTEC, INC.

MATERIAL:
INSULATOR: NYLON UL94V-0, COLOR: WHITE
CONTACT: PHOS BRONZE

DO NOT SCALE DRAWING SHEET SCALE: 3:1



520 PARK EAST BLVD, NEW ALBANY, IN 47150
PHONE: 812-944-6733 FAX: 812-948-5047
e-Mail: info@SAMTEC.com code 53322

DESCRIPTION:
1MM S1SD CABLE ASSEMBLY

DWG. NO.
S1SDX-XX-XXX-XX-XX.XX-LX

BY: VICKY Z 06/22/2013 SHEET 1 OF 3

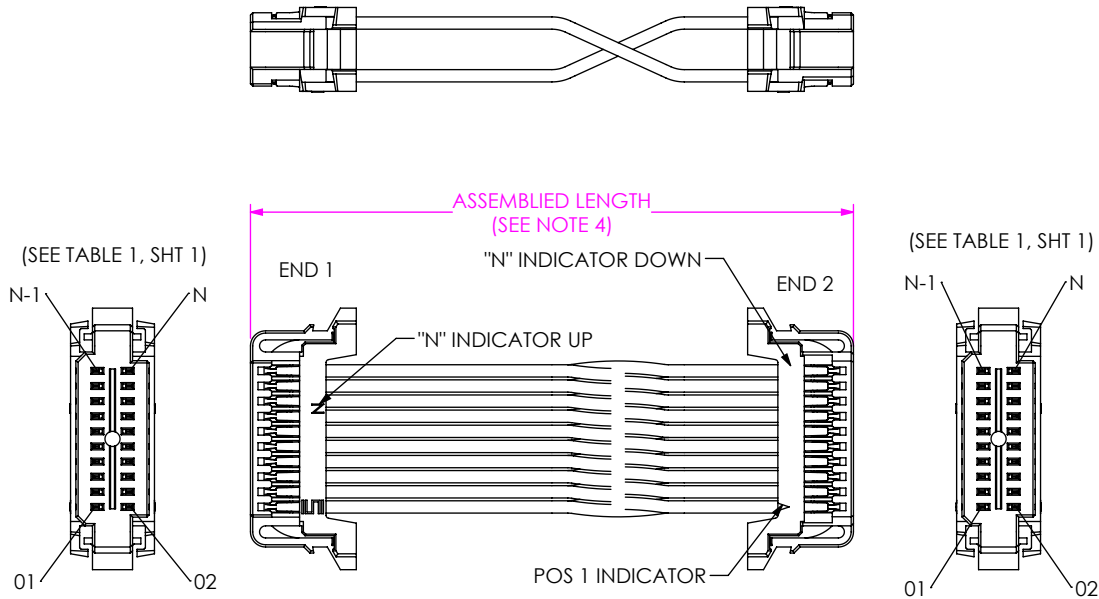

FIG 2
S1SD-10-XXX-XX-XX.XX-L1 SHOWN
(DIFFERENT AS SHOWN, OTHERWISE SAME AS FIG 1)

TABLE 2		
WIRE GAUGE	INSULATION	WIRE PART NUMBER
-28	PVC	DWC-28-10-300
	FEP	DWCT-28-01-TC
-30	PVC	DWC-30-10-300
	FEP	DWCT-30-01-TC

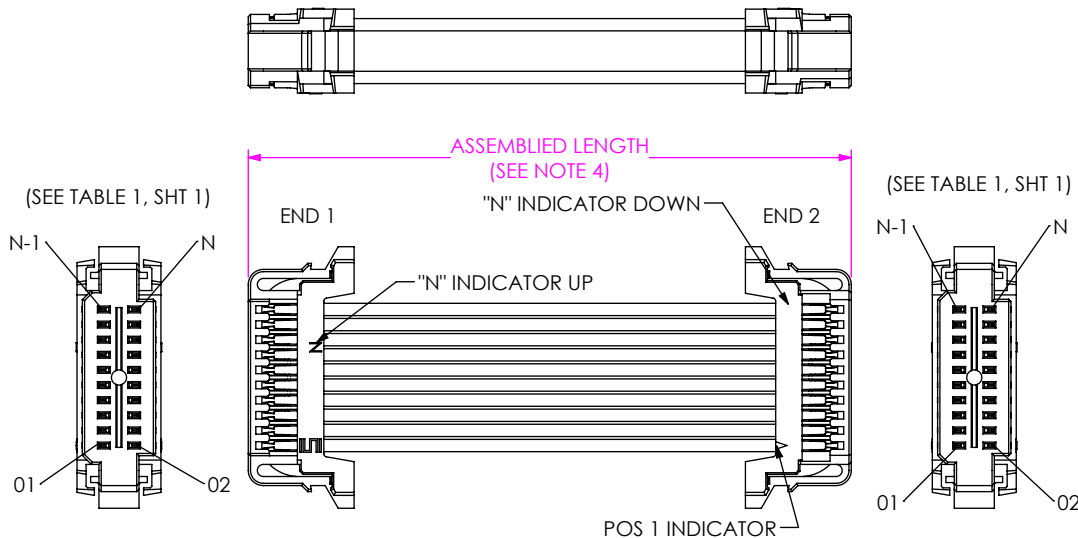

FIG 3
S1SD-10-XXX-XX-XX.XX-L2 SHOWN
(DIFFERENT AS SHOWN, OTHERWISE SAME AS FIG 1)

TABLE 4										
S1SD COLOR CODED WIRE SEQUENCE										
PIN#	COLOR									
	BROWN	RED	ORANGE	YELLOW	GREEN	BLUE	VIOLET	GRAY	WHITE	BLACK
	1	2	3	4	5	6	7	8	9	10
	11	12	13	14	15	16	17	18	19	20
	21	22	23	24	25	26	27	28	29	30
	31	32	33	34	35	36	37	38	39	40
28 AWG WIRE	DWC-28-01-300	DWC-28-02-300	DWC-28-03-300	DWC-28-04-300	DWC-28-05-300	DWC-28-13-300	DWC-28-07-300	DWC-28-08-300	DWC-28-09-300	DWC-28-10-300
30 AWG WIRE	DWC-30-01-300	DWC-30-02-300	DWC-30-03-300	DWC-30-04-300	DWC-30-05-300	DWC-30-13-300	DWC-30-07-300	DWC-30-08-300	DWC-30-09-300	DWC-30-10-300

PROPRIETARY NOTE
THIS DOCUMENT CONTAINS CONFIDENTIAL AND PROPRIETARY INFORMATION AND ALL DESIGN, MANUFACTURING, REPRODUCTION, USE, PATENT RIGHTS AND SALES RIGHTS ARE EXPRESSLY RESERVED BY SAMTEC, INC. THIS DOCUMENT SHALL NOT BE DISCLOSED, IN WHOLE OR PART, TO ANY UNAUTHORIZED PERSON OR ENTITY NOR REPRODUCED, TRANSFERRED OR INCORPORATED IN ANY OTHER PROJECT IN ANY MANNER WITHOUT THE EXPRESS WRITTEN CONSENT OF SAMTEC, INC.



520 PARK EAST BLVD, NEW ALBANY, IN 47150
PHONE: 812-944-6733 FAX: 812-948-5047
e-Mail info@SAMTEC.com code 55322

DO NOT SCALE DRAWING

SHEET SCALE: 2:1

DESCRIPTION: 1MM S1SD CABLE ASSEMBLY

DWG. NO. S1SDX-XX-XXX-XX-XX.XX-LX

BY: VICKY Z 06/22/2013 SHEET 2 OF 3

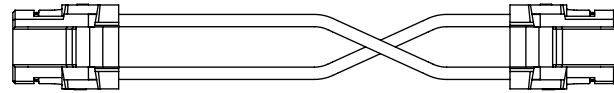

(SEE TABLE 1, SHT 1)

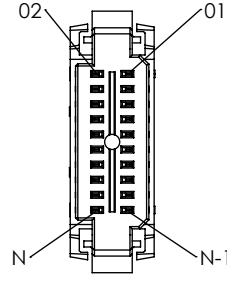
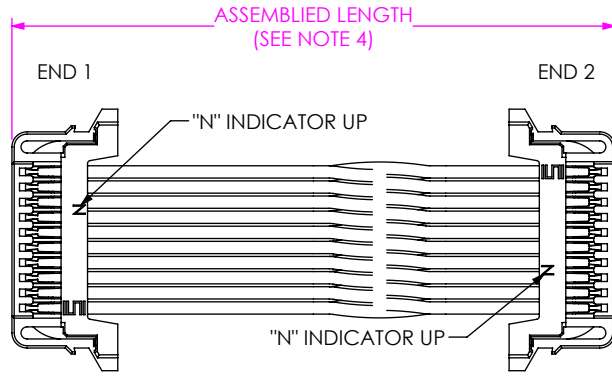
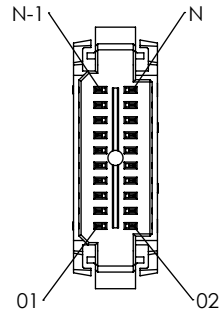

(SEE TABLE 1, SHT 1)

FIG 4
S1SD-10-XXX-XX-XX.XX-L3 SHOWN
(DIFFERENT AS SHOWN, OTHERWISE SAME AS FIG 1)

CABLE CUT IN-PROCESS

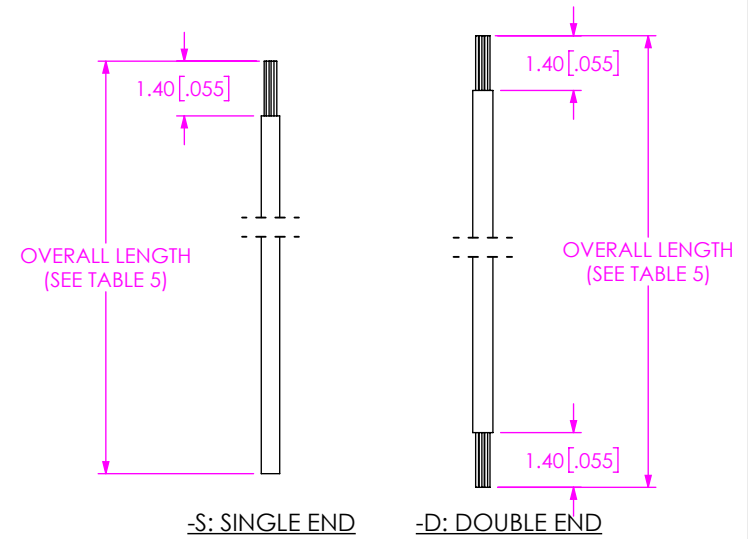

-S: SINGLE END -D: DOUBLE END

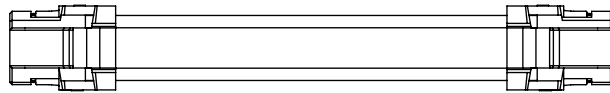

(SEE TABLE 1, SHT 1)

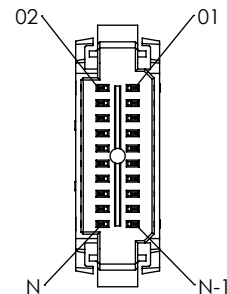
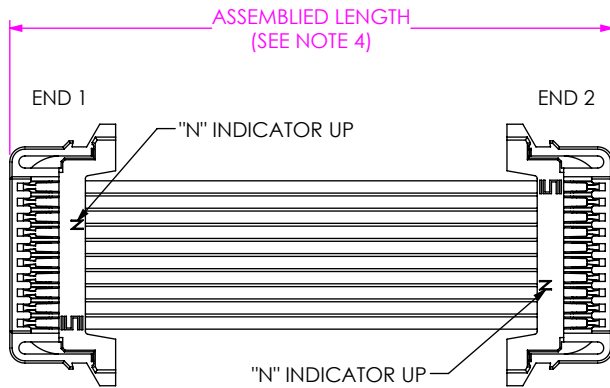
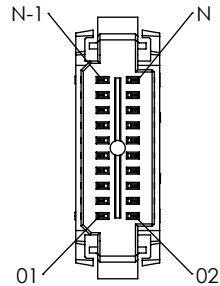

(SEE TABLE 1, SHT 1)

FIG 5
S1SD-10-XXX-XX-XX.XX-L4 SHOWN
(DIFFERENT AS SHOWN, OTHERWISE SAME AS FIG 1)

TABLE 5 (OVERALL LENGTH SUBTRACTORS) (SEE NOTE 10)	
	LENGTH
-S: SINGLE END	2.79 [.110]
-D: DOUBLE END	5.59 [.220]

PROPRIETARY NOTE
THIS DOCUMENT CONTAINS CONFIDENTIAL AND PROPRIETARY INFORMATION AND ALL DESIGN, MANUFACTURING, REPRODUCTION, USE, PATENT RIGHTS AND SALES RIGHTS ARE EXPRESSLY RESERVED BY SAMTEC, INC. THIS DOCUMENT SHALL NOT BE DISCLOSED, IN WHOLE OR PART, TO ANY UNAUTHORIZED PERSON OR ENTITY NOR REPRODUCED, TRANSFERRED OR INCORPORATED IN ANY OTHER PROJECT IN ANY MANNER WITHOUT THE EXPRESS WRITTEN CONSENT OF SAMTEC, INC.



520 PARK EAST BLVD, NEW ALBANY, IN 47150
PHONE: 812-944-6733 FAX: 812-948-5047
e-Mail info@SAMTEC.com code 55322

DO NOT SCALE DRAWING

SHEET SCALE: 2:1

DESCRIPTION: 1MM S1SD CABLE ASSEMBLY

DWG. NO. S1SDX-XX-XXX-XX-XX.XX-LX

BY: VICKY Z 06/22/2013 SHEET 3 OF 3