

12 CIRCUIT SMT USCAR HEADER  
POLARIZATION OPTION A

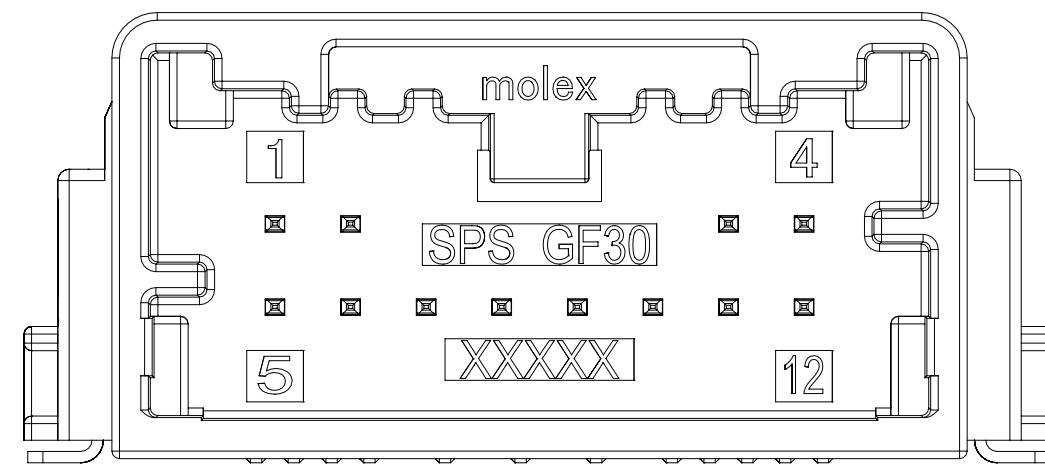

12 CIRCUIT SMT USCAR HEADER  
POLARIZATION OPTION B

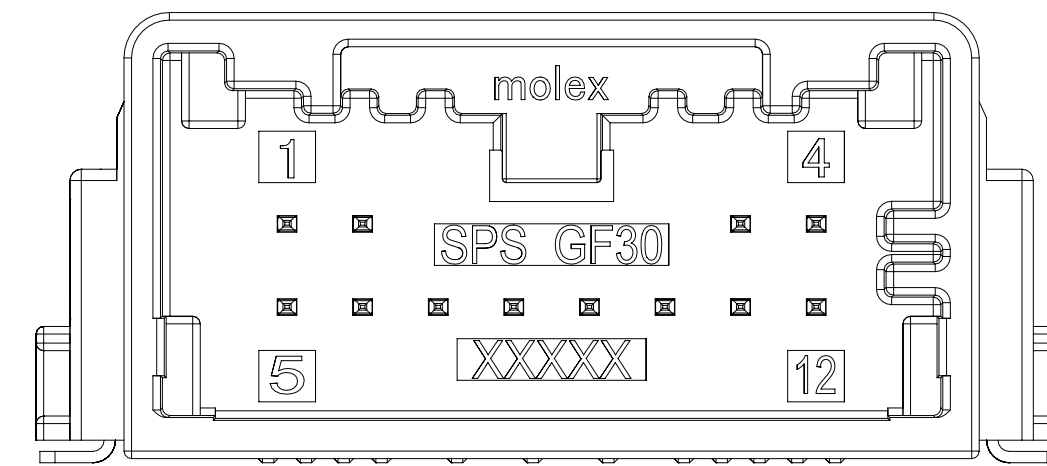

12 CIRCUIT SMT USCAR HEADER  
POLARIZATION OPTION C

24CKT POLARIZATION OPTIONS SHOWN BELOW  
ARE REPRESENTATIVE FOR 16 AND 20CKT

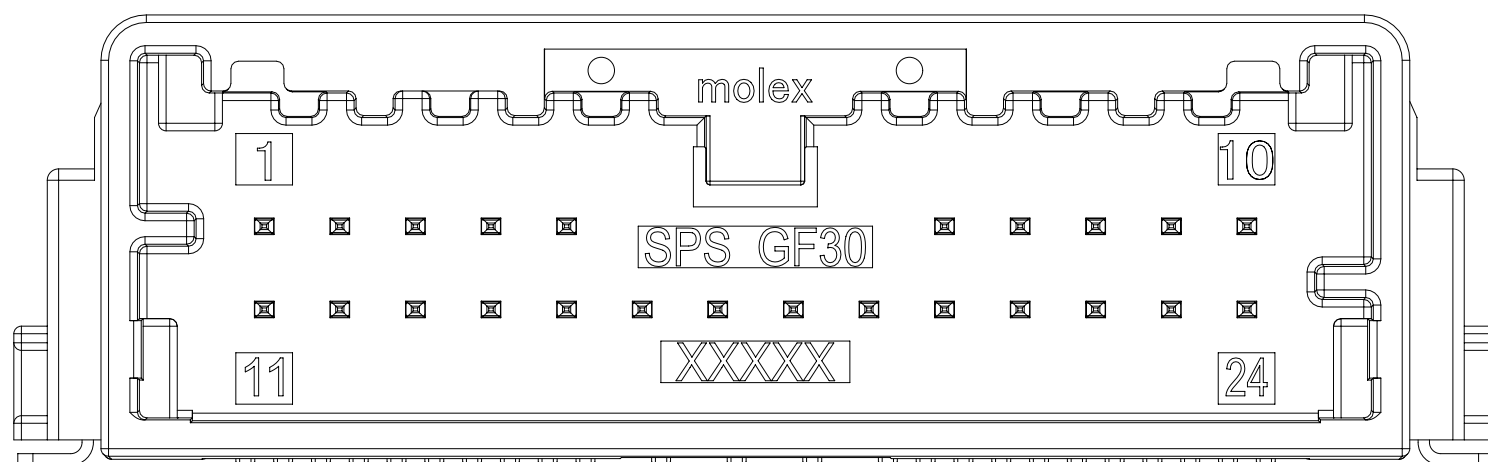

24 CIRCUIT SMT HEADER  
POLARIZATION OPTION A

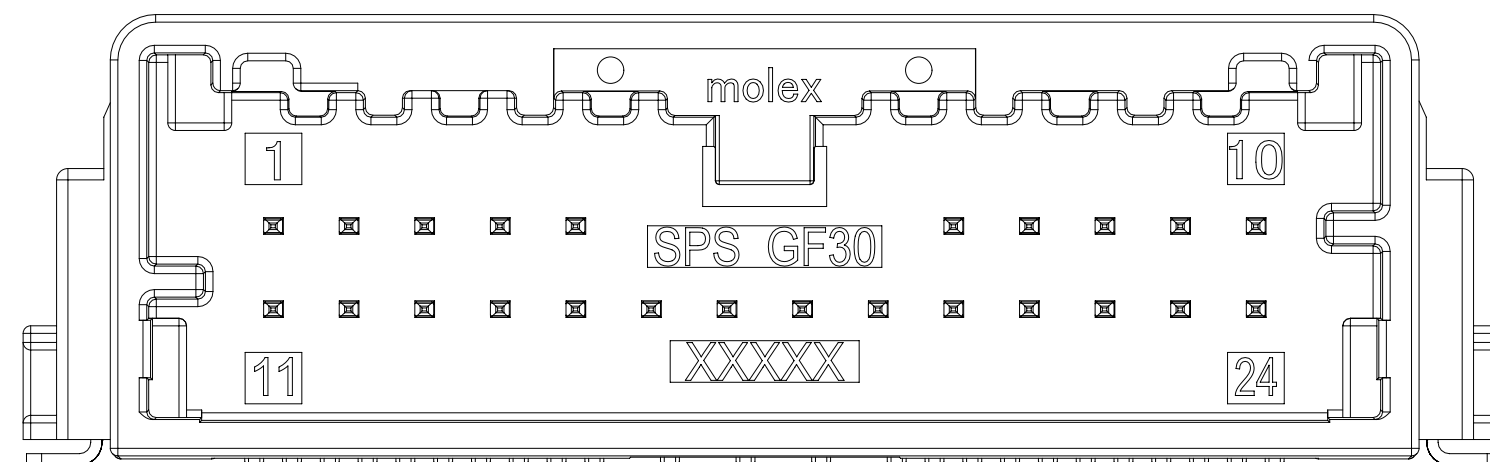

24 CIRCUIT SMT HEADER  
POLARIZATION OPTION B

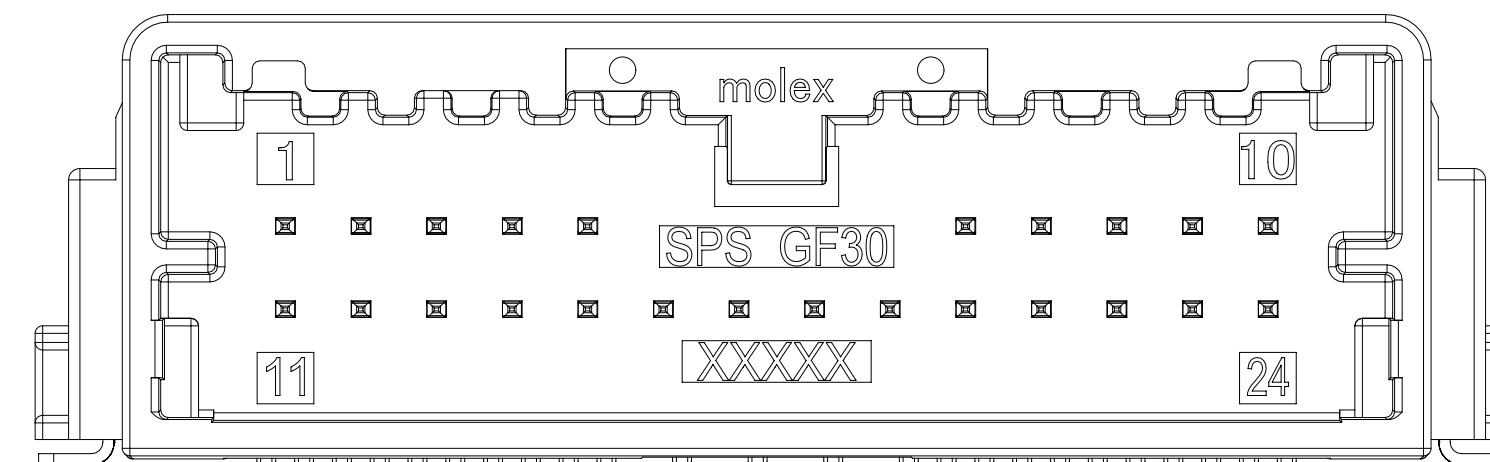

24 CIRCUIT SMT HEADER  
POLARIZATION OPTION C

NOTES: VALID UNLESS OTHERWISE SPECIFIED

1. GENERAL:
    - a. APPLICATION SPECIFICATION SEE: AS-34791-020
    - b. PRODUCT SPECIFICATION SEE: PS-34791-020
    - c. PACKAGING SPECIFICATION PER MOLEX DRAWING: SEE CHART
    - d. SOLDERABILITY PER SMES-152
    - e. PARTS MUST BE IN COMPLIANCE TO MOLEX CHEMICAL SUBSTANCES FOR PRODUCTS AND PACKAGING SPECIFICATION: QEHS-699000-300
    - f. DATA MUST BE SUBMITTED UNDER THE MOLEX PART NUMBER TO IMDS (COMPANY ID#13255)
    - g. FLAMMABILITY REQUIREMENT: PER ISO3795 OR GM3191
    - h. VISUAL DEFECTS SHALL MEET COSMETIC STANDARD PS-45499-002 (Class B)
  2. DESIGN - MATERIALS:
    - a. SHROUD (PLASTIC HOUSING): SPS 30% GF, 25% REGRIND MAX PER WEIGHT
    - b. BLADES:
      - BASE METAL: C26000 BRASS
      - PLATING REQUIREMENTS:
        - TIN:
          - UNDERPLATING:
            - OVERALL NICKEL: 1.25 - 2.25 MICROMETERS
          - OVERPLATING:
            - OVERALL TIN: 2.5 - 4.0 MICROMETERS
        - GOLD:
          - UNDERPLATING:
            - OVERALL NICKEL: 1.25 - 2.25 MICROMETERS
          - OVERPLATING:
            - CONTACT AREA: ELECTRODEPOSITED GOLD
              - MINIMUM 0.76 MICROMETERS HARD GOLD
            - PCB CONTACT AREA: ELECTRODEPOSITED TIN MATTE FINISH
              - MINIMUM 2.5 - 4.0 MICROMETERS
3. DESIGN - GEOMETRY:
  - a. THIS IS A 100% CAD GENERATED PART. THE CAD MATHEMATICAL DATA IS THE MASTER FOR THIS PART. FOR DIMENSIONAL OR ANY INFORMATION NOT SHOWN ON THIS DRAWING, ANALYZE THE CAD MODEL.
  - b. GEOMETRIC DIMENSIONS AND TOLERANCES PER ASME Y14.5M - 2009
  - c. GENERAL TOLERANCES: SEE TITLE BLOCK
  - d. EDGES AND UNDIMENSIONED DETAILS PER ISO13715
  - e. CORNERS SHOWN AS SHARP TO BE R 0.1 MAX
  - f. LETTERING SHALL BE BELOW SURROUNDING SURFACE OF PART. THIS INCLUDES RECYCLING CODE, PLANT AND CAVITY ID, VENDOR ID, AND CIRCUIT ID.
  - g. INTERFACE - USCAR
    - 050-U-012-2-ZXX
    - 050-U-016-2-ZXX
    - 050-U-020-2-ZXX
    - 050-U-024-2-ZXX

V0 IDENTIFIER  
APPLIES FOR 12-24CKT

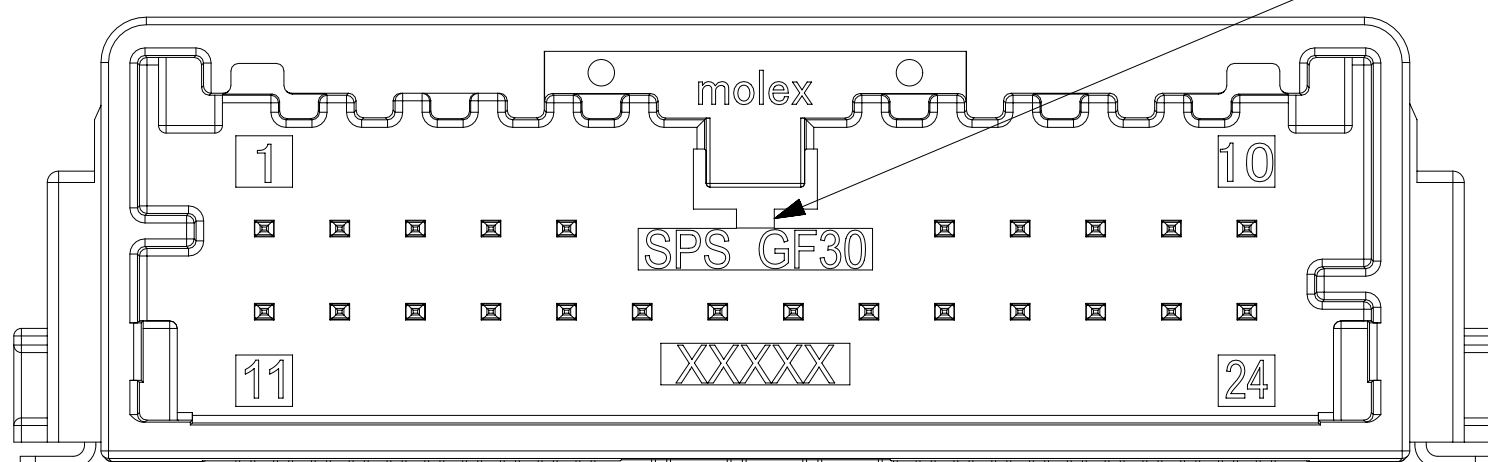

INSPECTION BALLON NUMBER LOG	
PER DRAWING REVISION: W11	
LAST BALLOON USED: 16	
ADDED BALLOON NUMBERS: 1A, 4A, 7A, 10A	
REMOVED BALLOON NUMBERS:	
REV	DESCRIPTION
W11	SHEET 5: REMOVED AVAILABILITY AND MATING COLUMNS ON BOM
W10	SHEET 5: ADDED MATING COMPONENT NOTE
W9	SHEET 1: ADDED V0 VIEW SHEET 5: REORGANIZED BOM TABLE
W8	DRAWING REMASTERED SHEET 1: UPDATED NOTE 2b BASE METAL SHEET 1: ADDED NOTE 3g SHEET 2: SOLDERNAIL POCKET DIMS UPDATED SHEET 3: ADDED BALLOONS 13A & 13B SHEET 5: ADDED V0 TIN PART NUMBERS TO BOM
W7	UPDATED INSPECTION LOG, CHANGED DESCRIPTION, ADDED BASIC DIMS TO SHEET 2
W6	DELETED 34897-6164
W5	ADDED DIM BALLOON 15 & 16
W4	ADDED 16CKT GOLD DEPOPULATED POL A P/N
W3	NX REMASTERING

THIS DRAWING CONTAINS INFORMATION THAT IS PROPRIETARY TO MOLEX ELECTRONIC TECHNOLOGIES, LLC AND SHOULD NOT BE USED WITHOUT WRITTEN PERMISSION

DIMENSION UNITS	SCALE	CURRENT REV DESC:	
mm	5:1		
GENERAL TOLERANCES (UNLESS SPECIFIED)			
ANGULAR TOL	± 1.0°		
4 PLACES	±		
3 PLACES	±		
2 PLACES	± 0.1		
1 PLACE	± 0.2		
0 PLACES	±		
DRAFT WHERE APPLICABLE MUST REMAIN WITHIN DIMENSIONS		THIRD ANGLE PROJECTION	DRAWING
			D-SIZE
		SERIES	34897

<b>molex</b>			
MINI50 12-24CKT SMT HDR SALES DRAWING			
PRODUCT CUSTOMER DRAWING			
DOCUMENT NUMBER	DOC TYPE	DOC PART	REVISION
SD-34897-001	PSD	000	W11
MATERIAL NUMBER	CUSTOMER	SHEET NUMBER	
	GENERAL MARKET	1 OF 5	

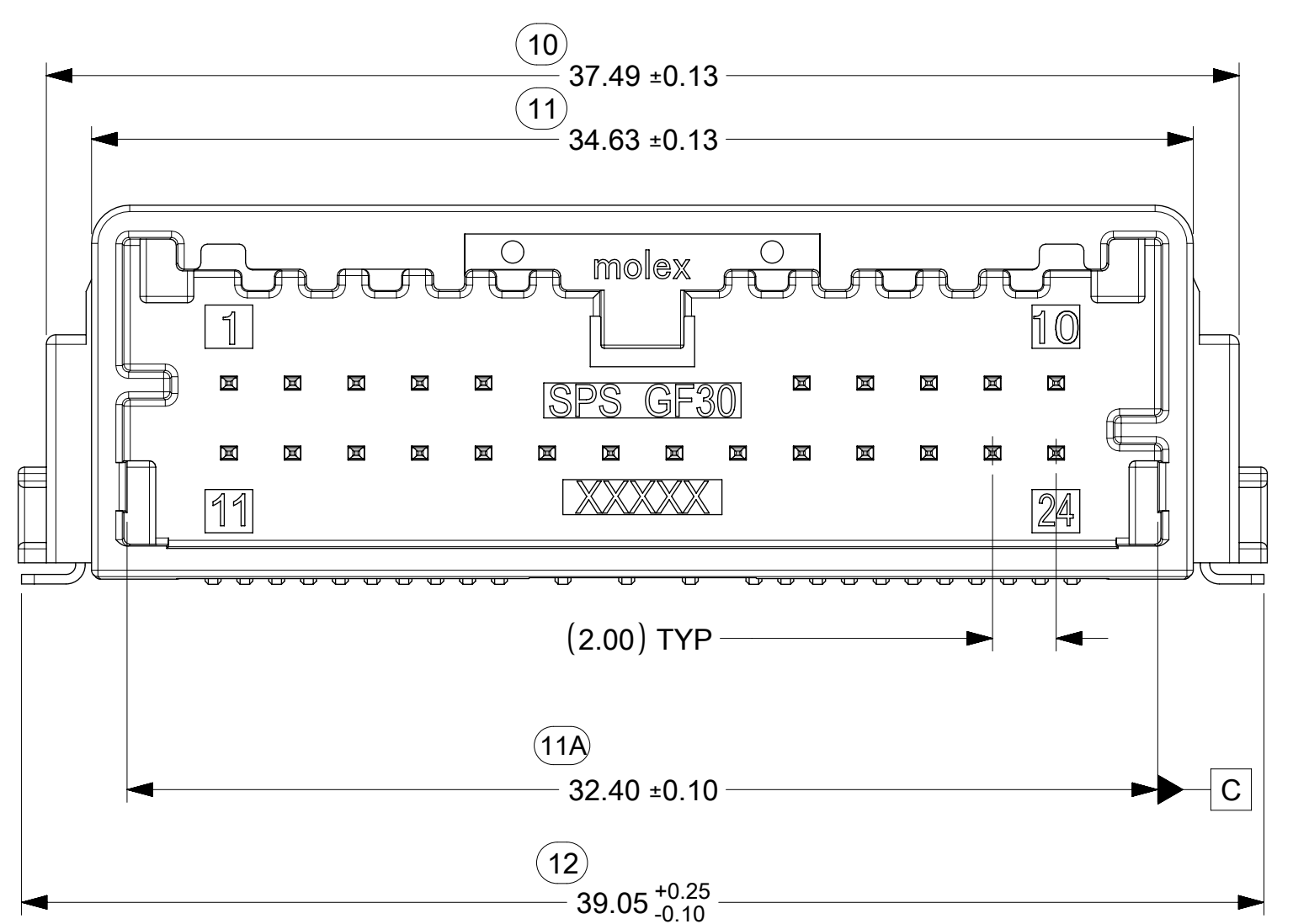
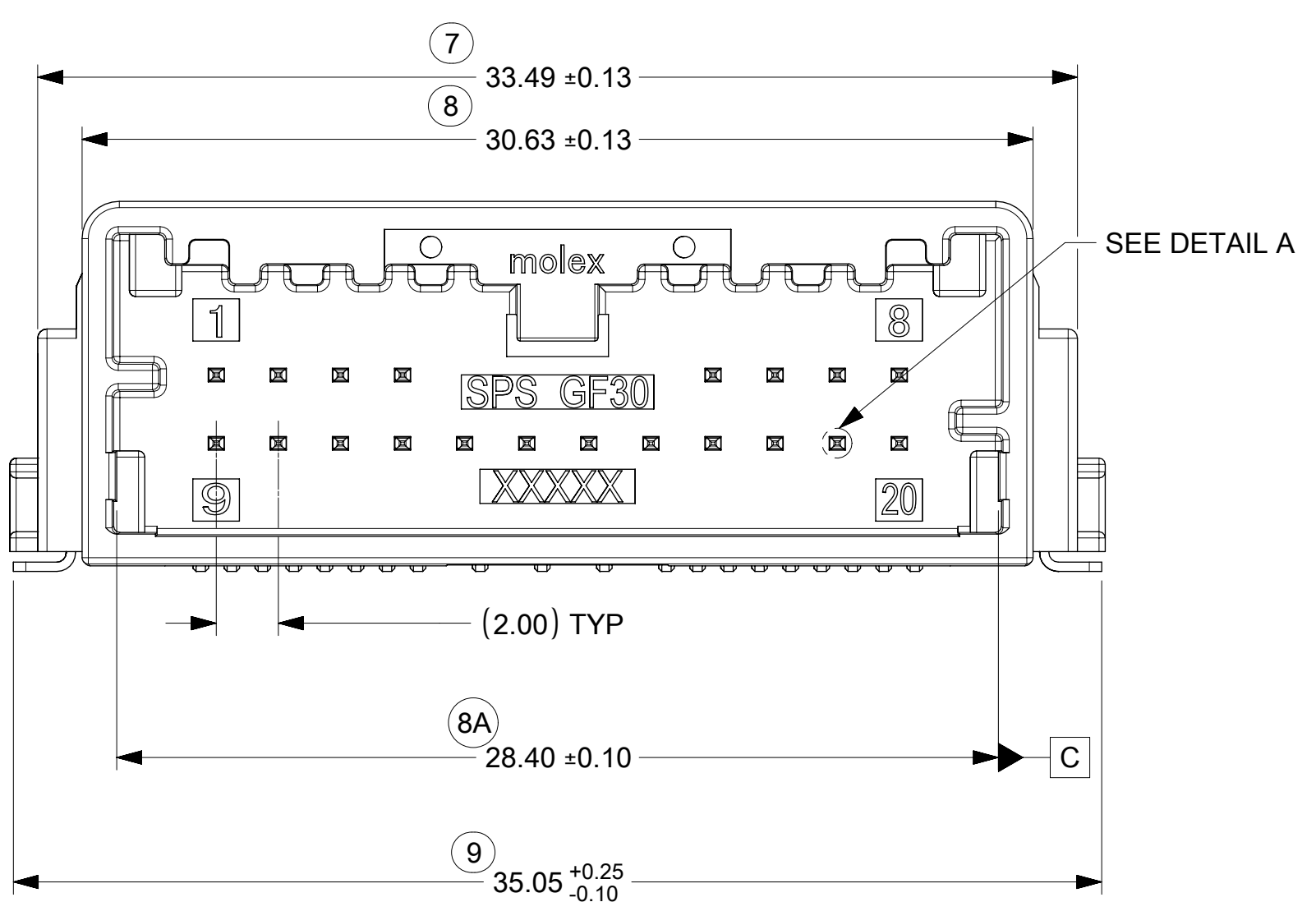
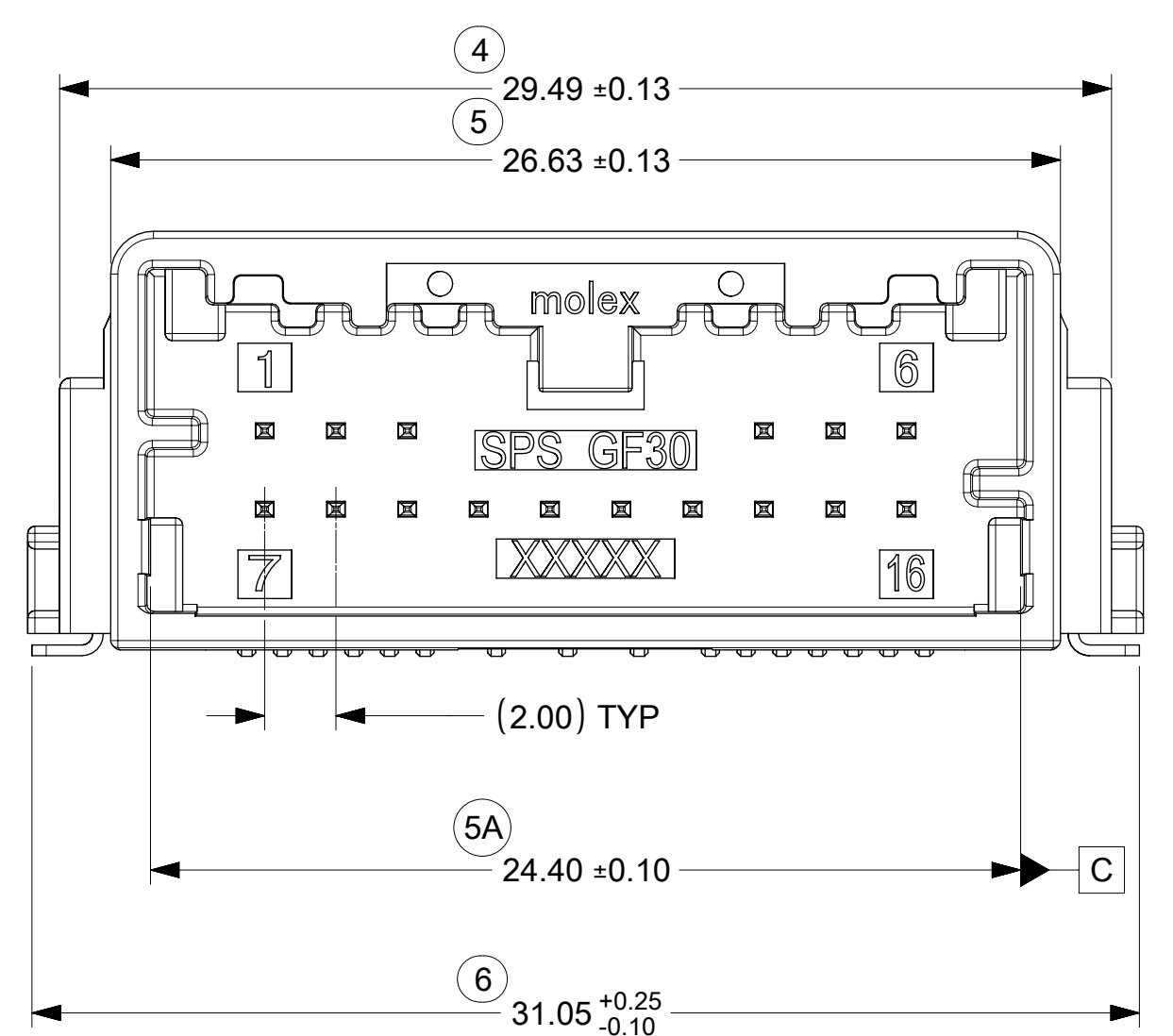
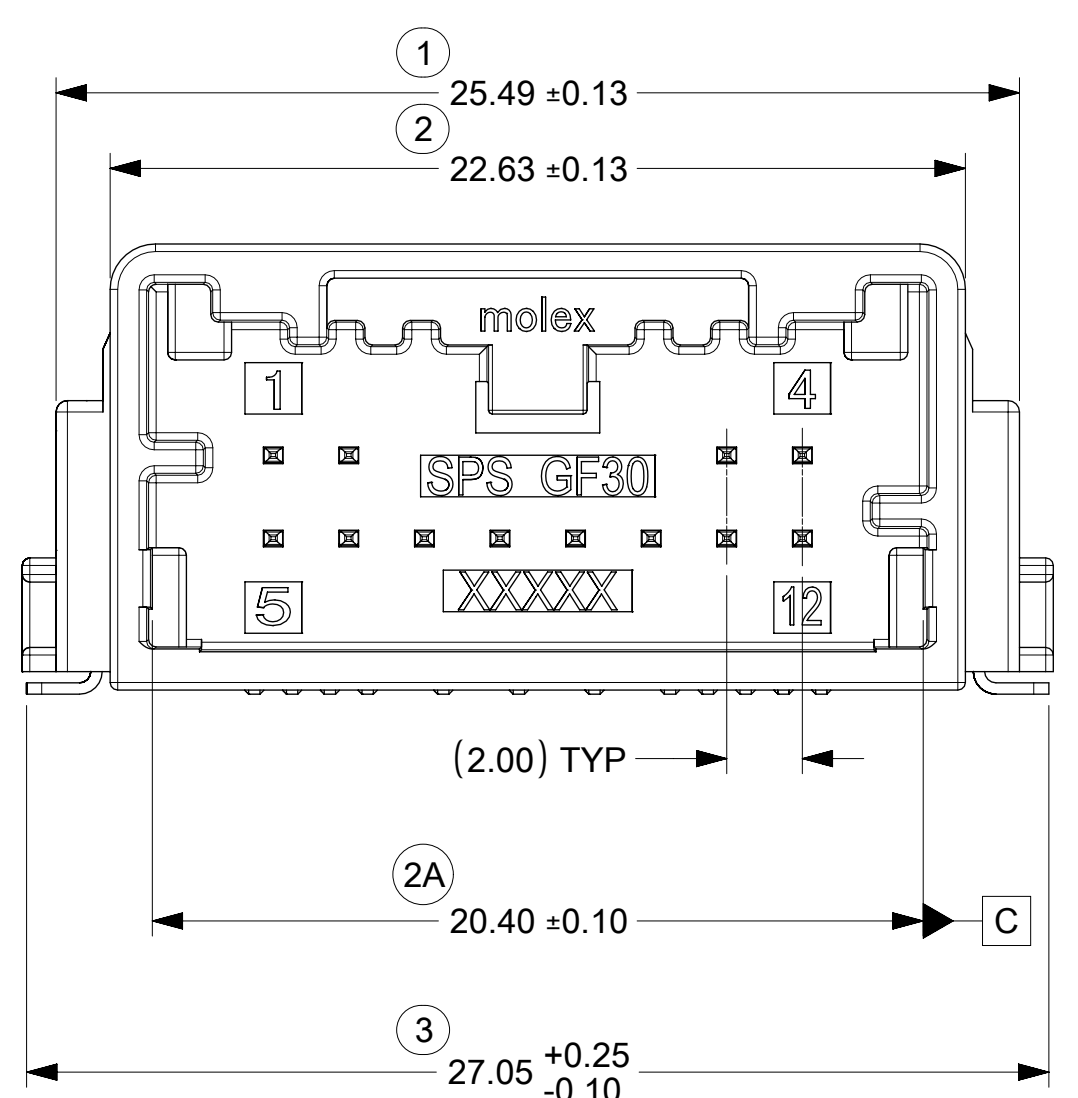
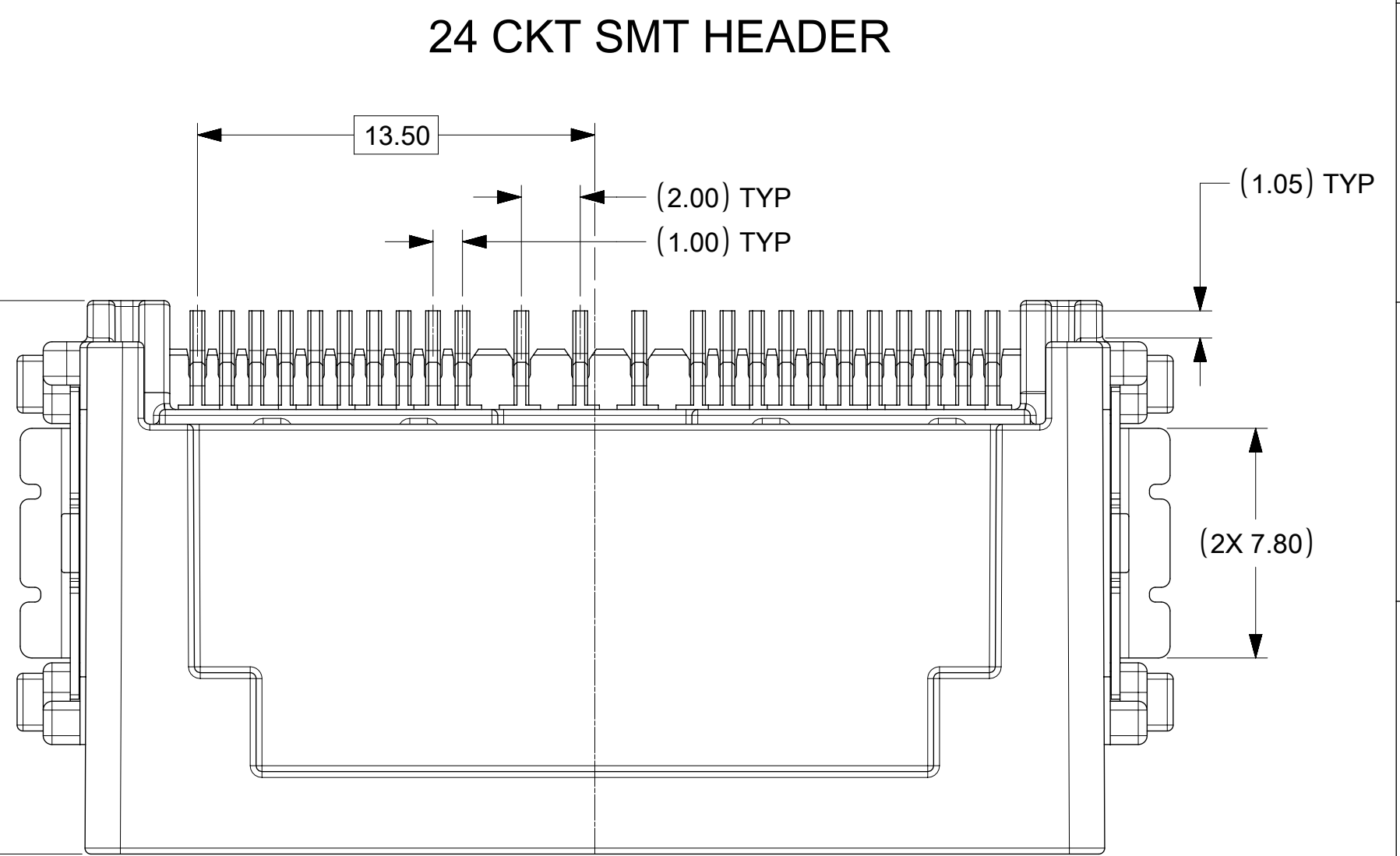
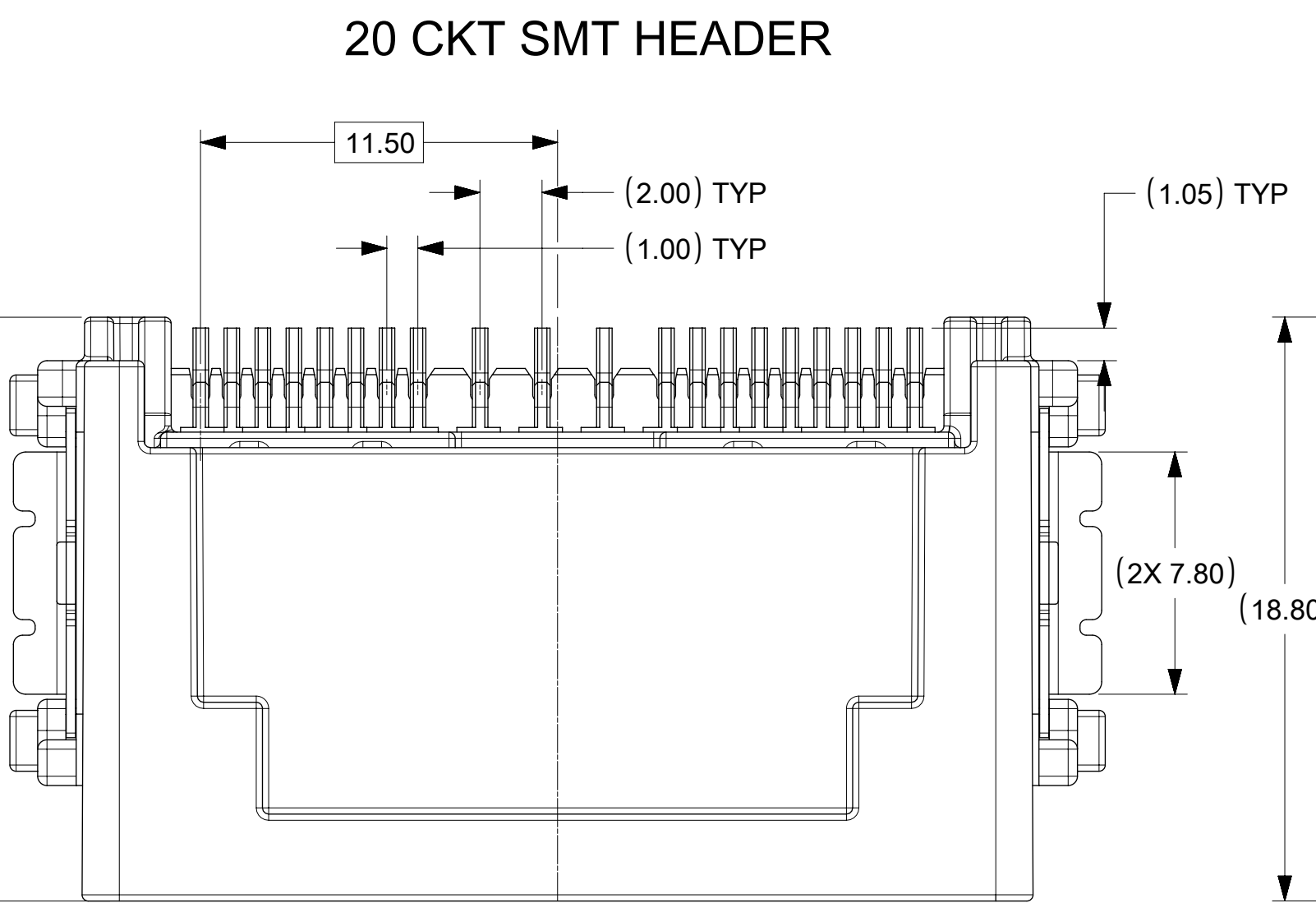
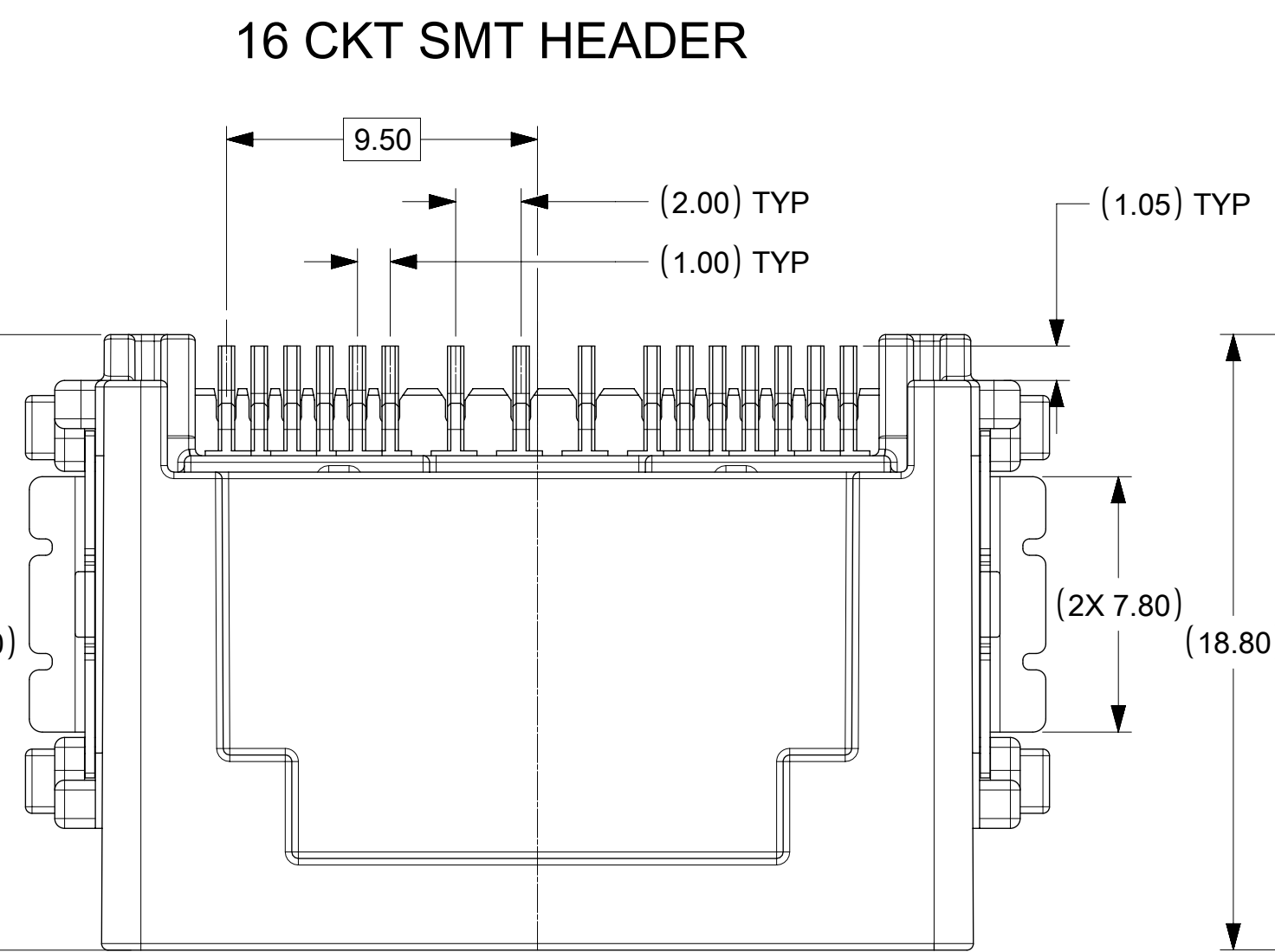
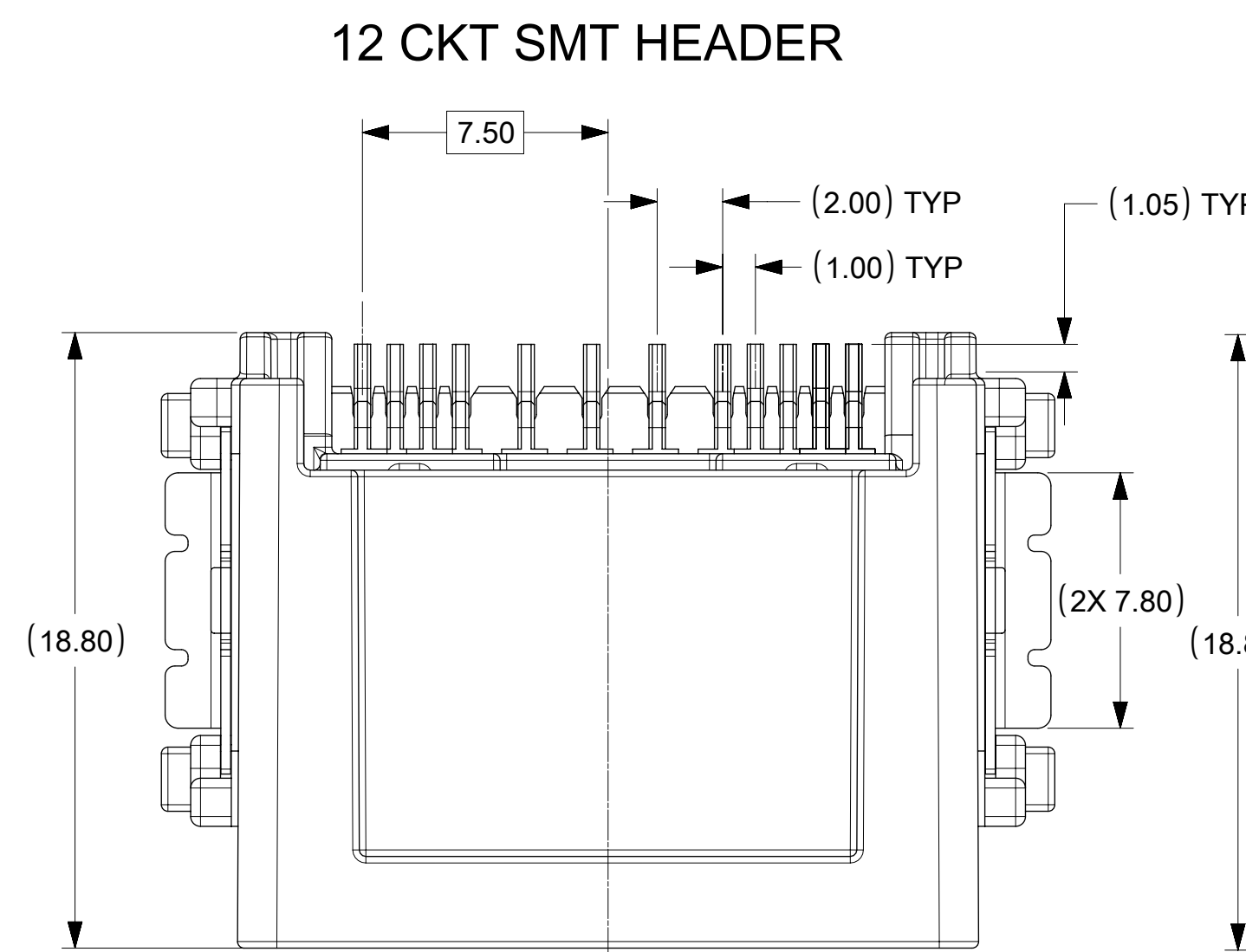

POST-REFLOW MINIMUM LATCH HEIGHT  
24 CKT HEADER ASSEMBLY SHOWN AS EXAMPLE

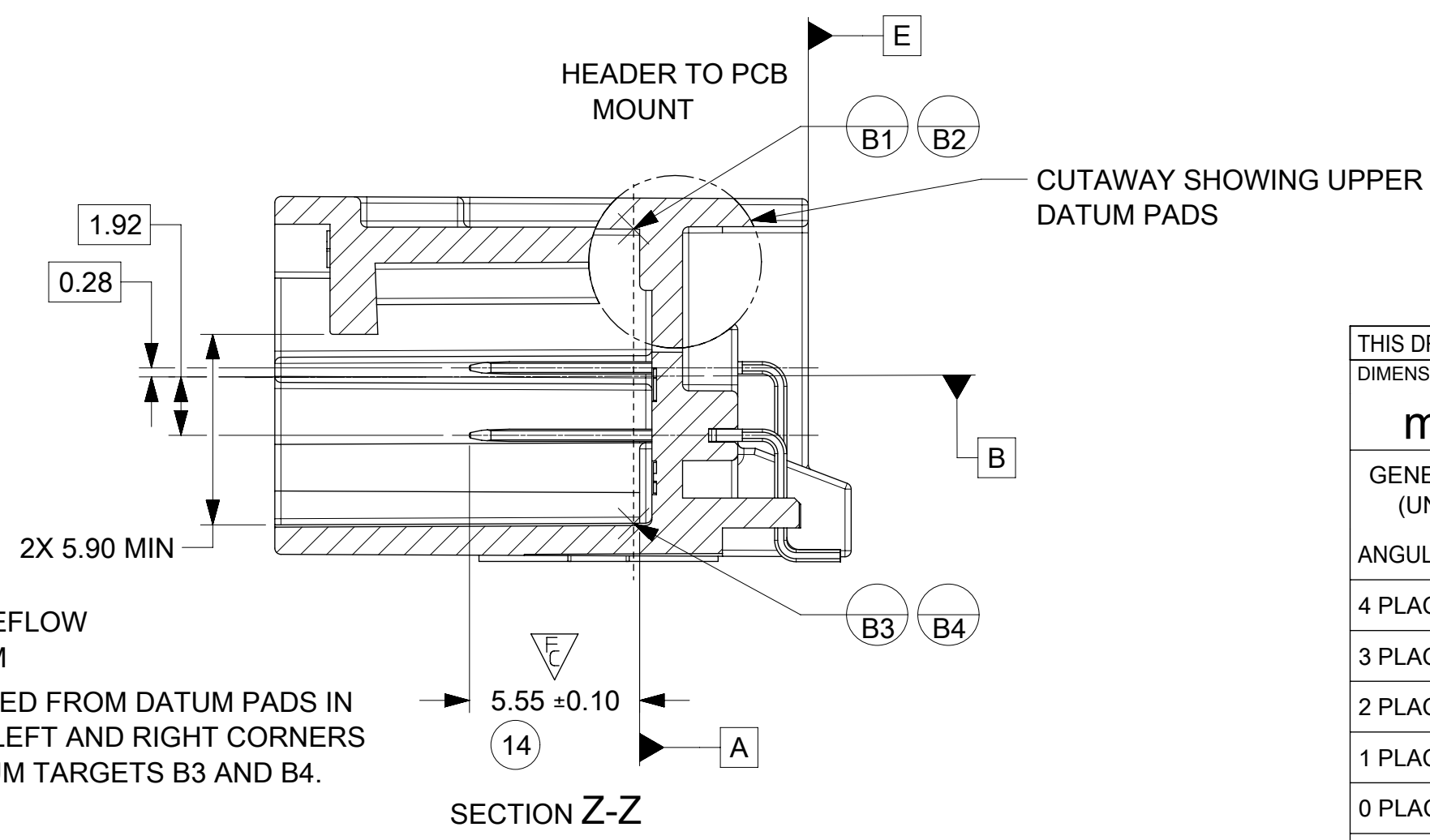
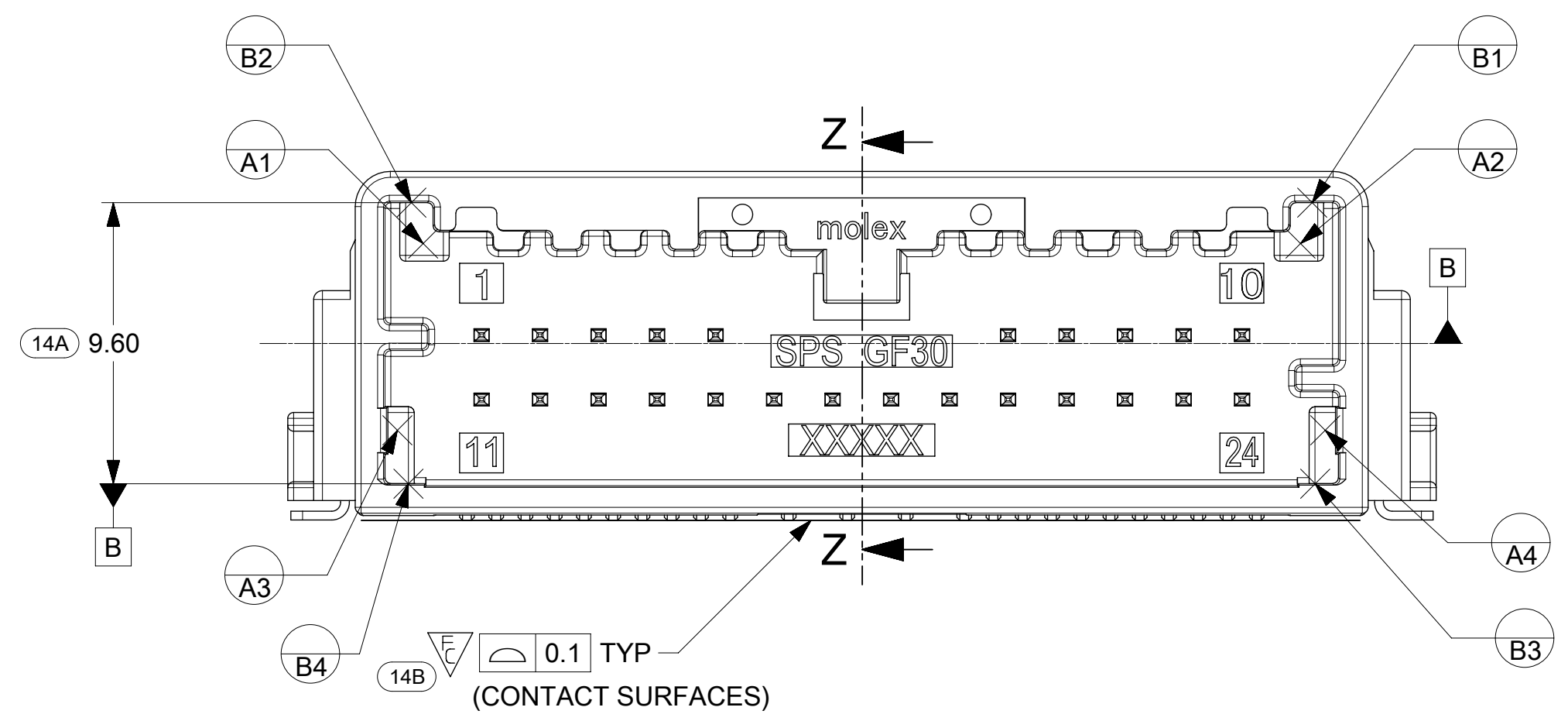
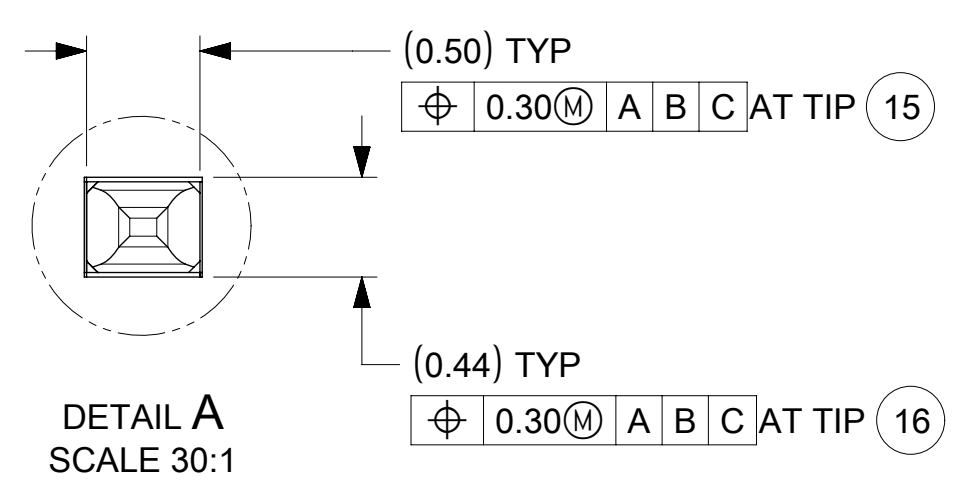

\*POST REFLOW MINIMUM  
MEASURED FROM DATUM PADS IN LOWER LEFT AND RIGHT CORNERS TO DATUM TARGETS B3 AND B4.

THIS DRAWING CONTAINS INFORMATION THAT IS PROPRIETARY TO MOLEX ELECTRONIC TECHNOLOGIES, LLC AND SHOULD NOT BE USED WITHOUT WRITTEN PERMISSION																													
DIMENSION UNITS		SCALE		CURRENT REV DESC:																									
mm		5:1																											
GENERAL TOLERANCES (UNLESS SPECIFIED)																													
ANGULAR TOL ± 1.0°																													
4 PLACES		±		EC NO: 659285																									
3 PLACES		±		DRWN: SRUSS 2021/03/16																									
2 PLACES		± 0.1		CHK'D: KHEWITT 2021/03/25																									
1 PLACE		± 0.2		APPR: JDUNAJ 2021/03/25																									
0 PLACES		±		INITIAL REVISION:																									
				DRWN: SMAHESHBABU 2017/03/20																									
				APPR: KHEWITT 2017/06/21																									
DRAFT WHERE APPLICABLE MUST REMAIN WITHIN DIMENSIONS			THIRD ANGLE PROJECTION		DRAWING		SERIES		MATERIAL NUMBER																				
			D-SIZE		34897		GENERAL MARKET		CUSTOMER																				
DOCUMENT STATUS				P1		RELEASE DATE		2021/03/25 19:03:47																					
<table border="1"> <tr> <td colspan="2">SD-34897-001</td> <td colspan="2">PSD</td> <td colspan="2">000</td> <td colspan="2">W11</td> <td colspan="2">SHEET NUMBER</td> </tr> <tr> <td colspan="2"></td> <td colspan="2">GENERAL MARKET</td> <td colspan="2"></td> <td colspan="2"></td> <td colspan="2">2 OF 5</td> </tr> </table>										SD-34897-001		PSD		000		W11		SHEET NUMBER				GENERAL MARKET						2 OF 5	
SD-34897-001		PSD		000		W11		SHEET NUMBER																					
		GENERAL MARKET						2 OF 5																					

**BEFORE REFLOW SOLDERING  
TEMPERATURE EXPOSURE**

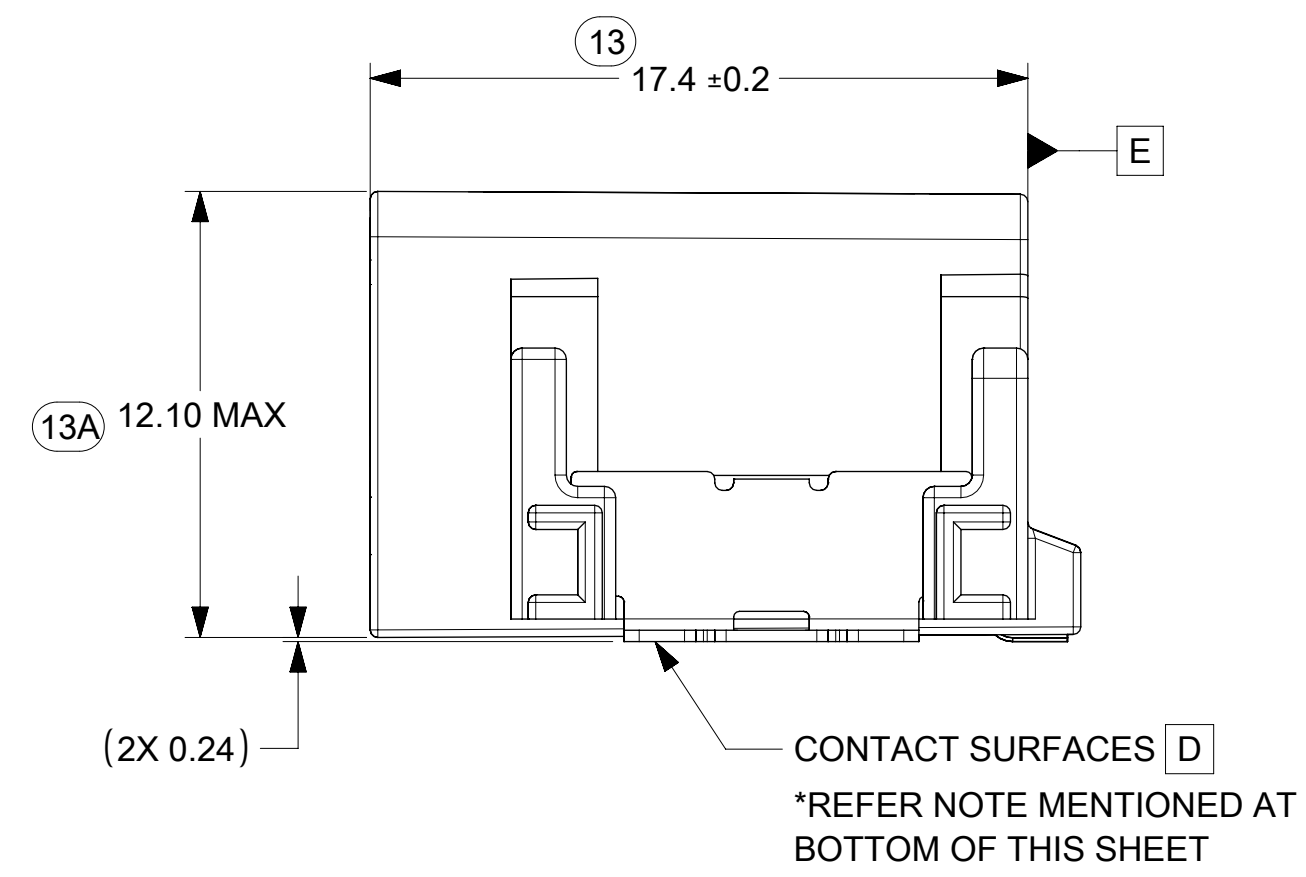

**AFTER REFLOW SOLDERING  
TEMPERATURE EXPOSURE**

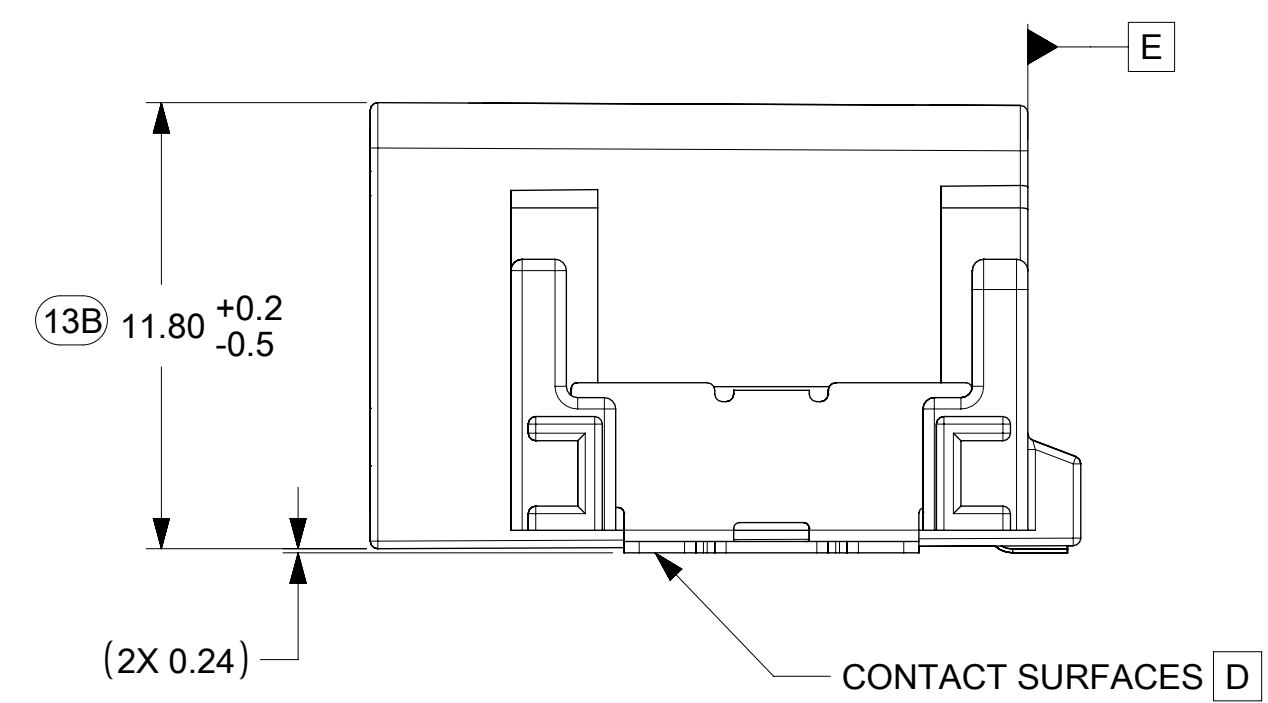

NOTE:  
CONTACTS PER CKT:  
12 CKT - 14 CONTACTS  
16 CKT - 18 CONTACTS  
20 CKT - 22 CONTACTS  
24 CKT - 26 CONTACTS

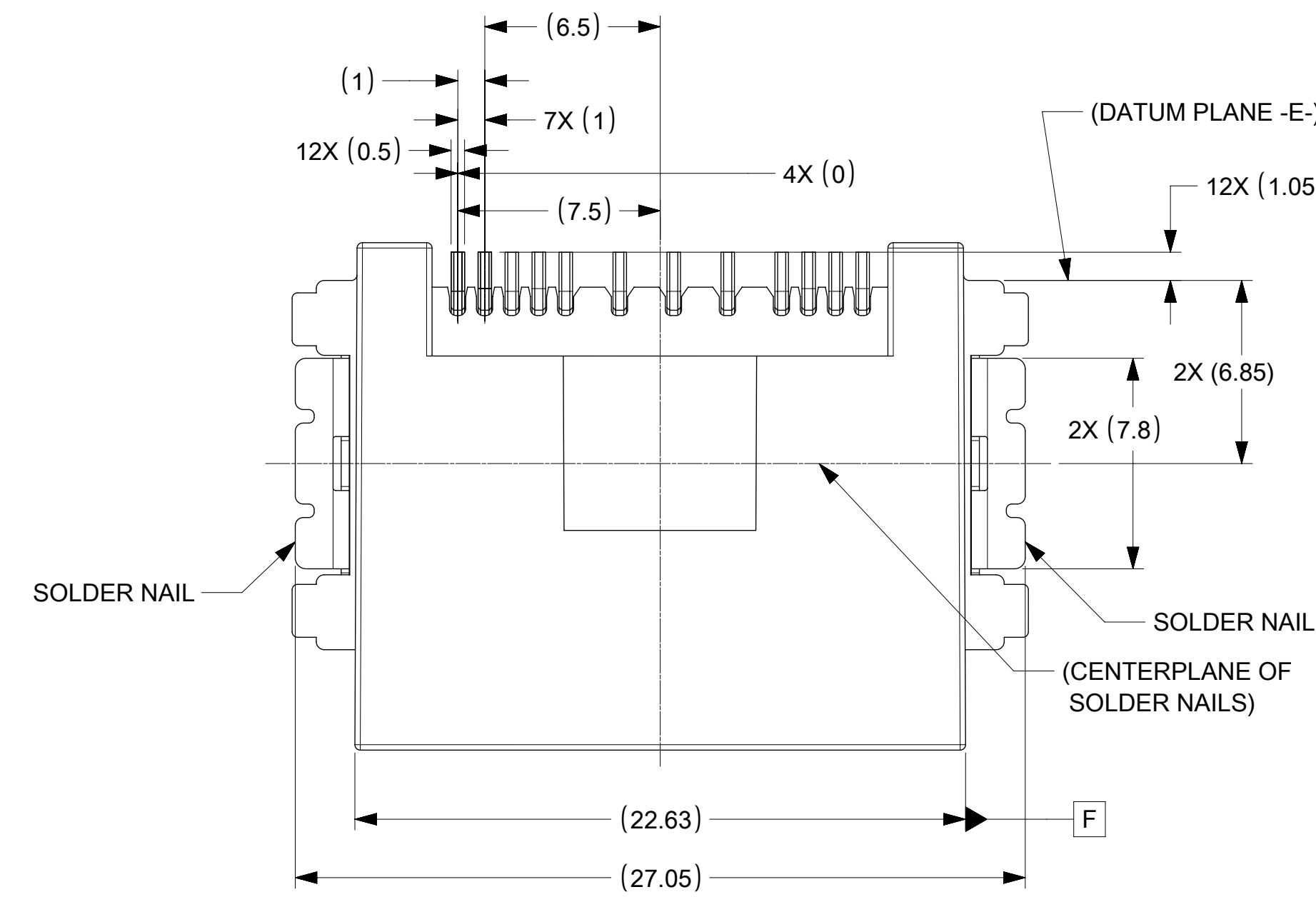

**12 CKT SMT HEADER (BOTTOM VIEW)  
(OTHER CIRCUIT SIZES ARE SIMILAR)**

**RECOMMENDED PCB LAYOUT:**

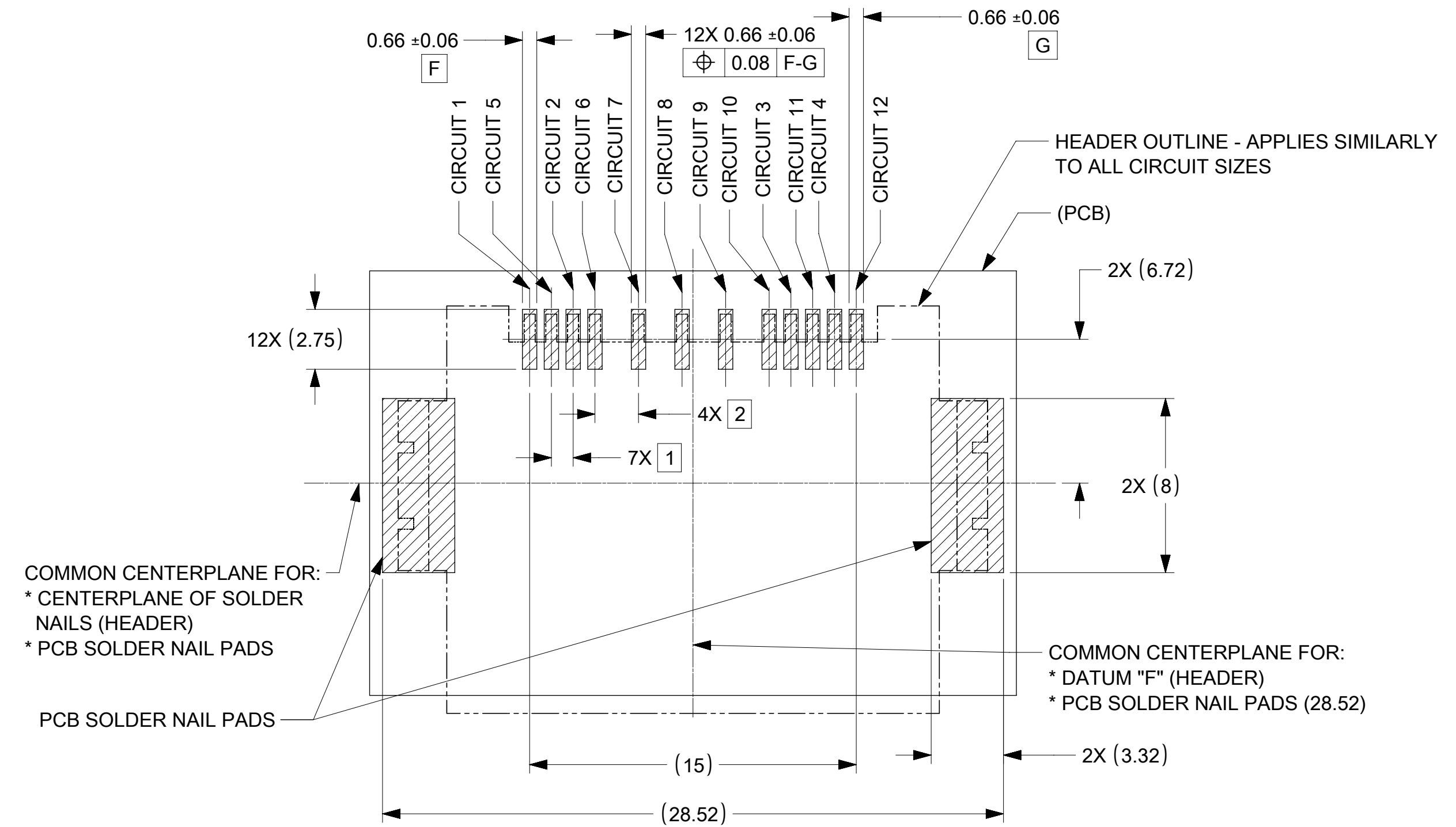

**12 CKT PCB LAYOUT**

THIS DRAWING CONTAINS INFORMATION THAT IS PROPRIETARY TO MOLEX ELECTRONIC TECHNOLOGIES, LLC AND SHOULD NOT BE USED WITHOUT WRITTEN PERMISSION									
DIMENSION UNITS	SCALE	CURRENT REV DESC:							
mm	5:1	<p><b>molex</b></p> <p>MINI50 12-24CKT SMT HDR SALES DRAWING</p> <p>PRODUCT CUSTOMER DRAWING</p> <p>DOCUMENT NUMBER: <b>SD-34897-001</b>    DOC TYPE: PSD    DOC PART: 000    REVISION: W11</p> <p>MATERIAL NUMBER: 34897    CUSTOMER: GENERAL MARKET    SHEET NUMBER: 3 OF 5</p>							
GENERAL TOLERANCES (UNLESS SPECIFIED)									
ANGULAR TOL	± 1.0°								
4 PLACES	±								
3 PLACES	±								
2 PLACES	± 0.1								
1 PLACE	± 0.2								
0 PLACES	±	EC NO: 659285	2021/03/16						
DRAFT WHERE APPLICABLE MUST REMAIN WITHIN DIMENSIONS		DRWN: SRUSS	2021/03/25						
THIRD ANGLE PROJECTION		CHK'D: KHEWITT	2021/03/25						
DRAWING		APPR: JDUNAJ	2021/03/25						
D-SIZE		INITIAL REVISION:							
SERIES		DRWN: SMAHESHBABU	2017/03/20						
34897		APPR: KHEWITT	2017/06/21						

### 16 CKT PCB LAYOUT

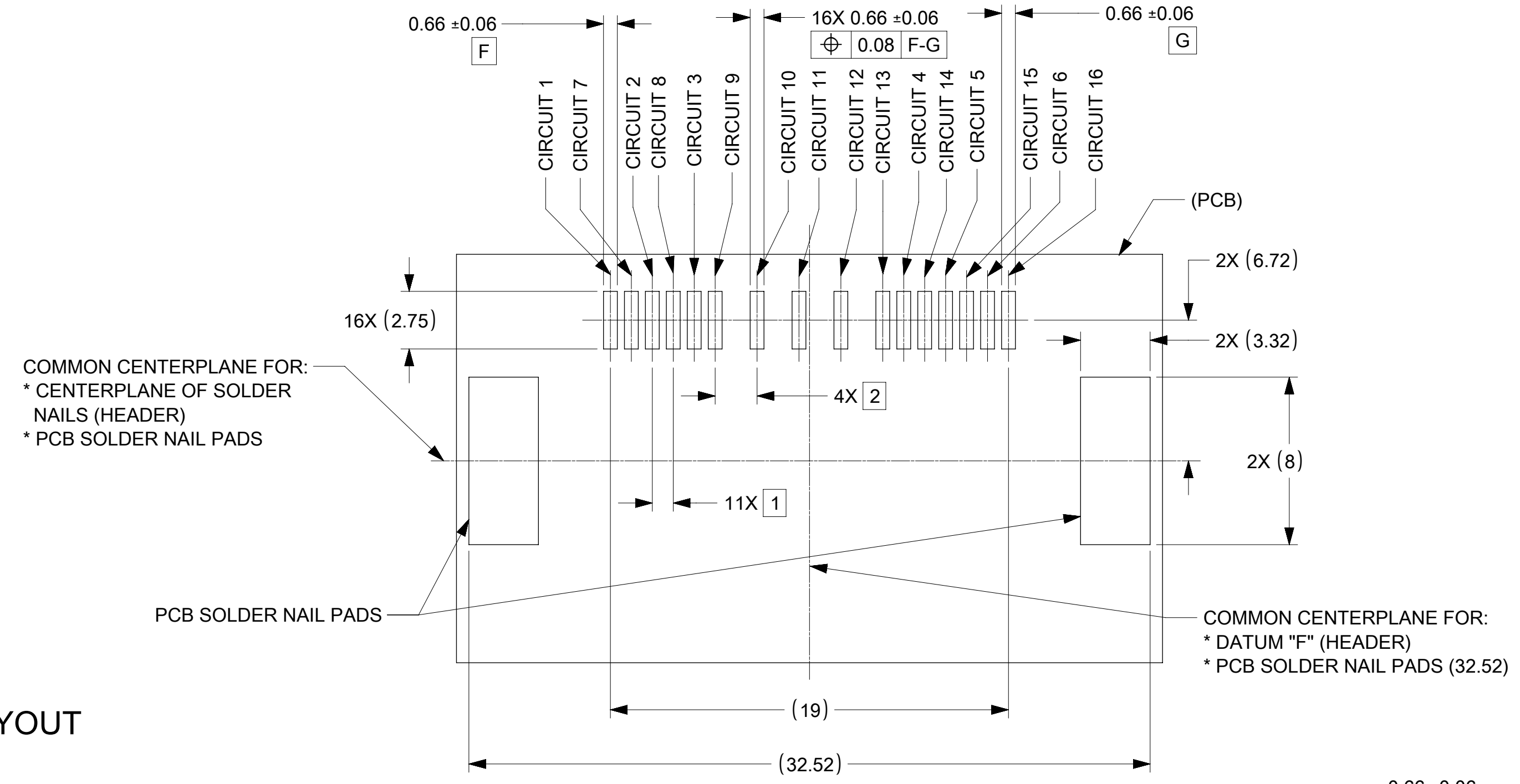

### RECOMMENDED PCB LAYOUT:

### 24 CKT PCB LAYOUT

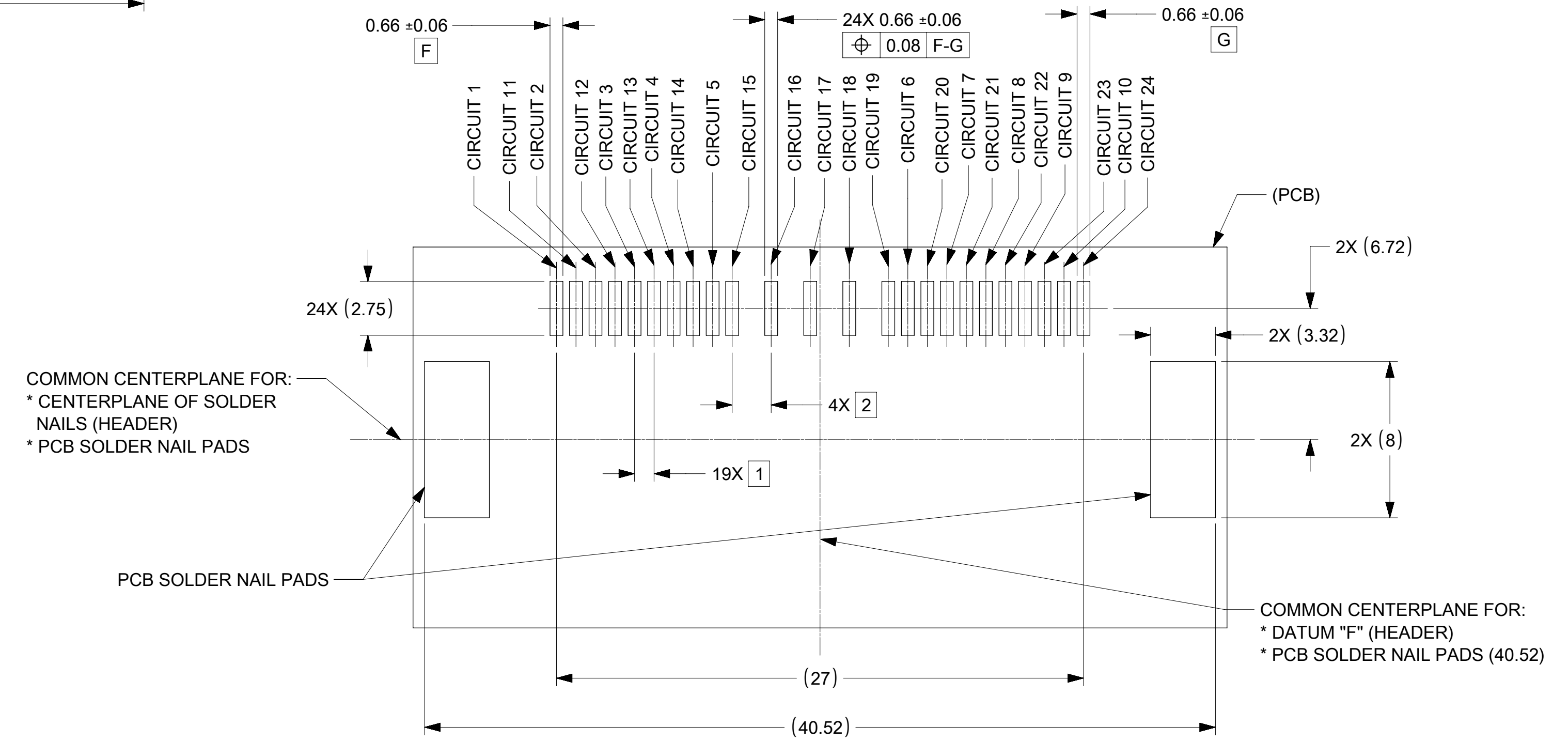

### 20 CKT PCB LAYOUT

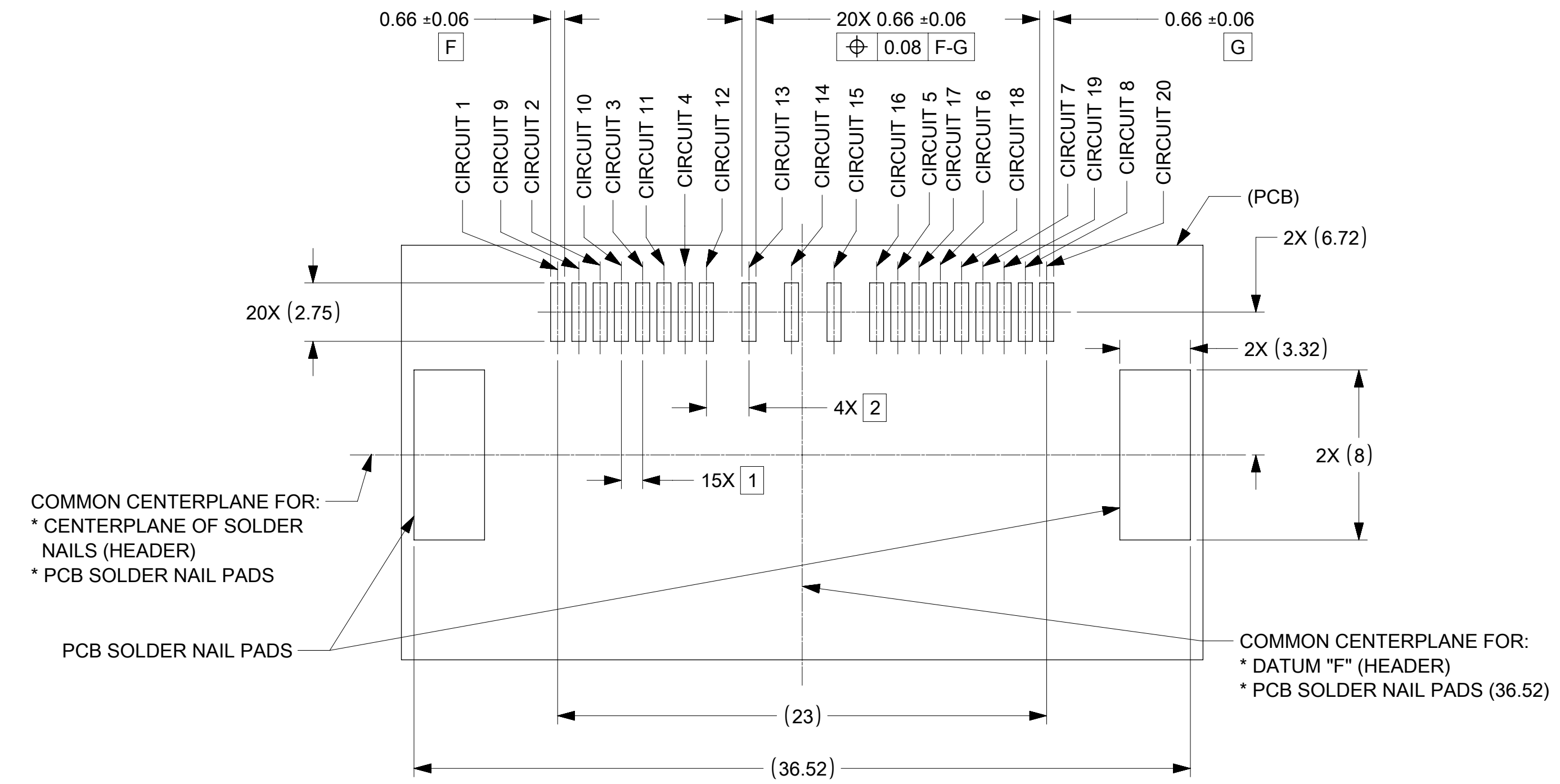

THIS DRAWING CONTAINS INFORMATION THAT IS PROPRIETARY TO MOLEX ELECTRONIC TECHNOLOGIES, LLC AND SHOULD NOT BE USED WITHOUT WRITTEN PERMISSION									
DIMENSION UNITS	SCALE	CURRENT REV DESC:							
mm	5:1								
GENERAL TOLERANCES (UNLESS SPECIFIED)									
ANGULAR TOL	± 1.0°								
4 PLACES	±	EC NO: 659285							
3 PLACES	±	DRWN: SRUSS 2021/03/16							
2 PLACES	± 0.1	CHK'D: KHEWITT 2021/03/25							
1 PLACE	± 0.2	APPR: JDUNAJ 2021/03/25							
0 PLACES	±	INITIAL REVISION:							
DRAFT WHERE APPLICABLE MUST REMAIN WITHIN DIMENSIONS		THIRD ANGLE PROJECTION		DRAWING		SERIES		MATERIAL NUMBER	
		D-SIZE		34897		GENERAL MARKET		CUSTOMER	
								SHEET NUMBER	
								4 OF 5	



MINI50 12-24CKT SMT HDR SALES DRAWING

PRODUCT CUSTOMER DRAWING

DOCUMENT NUMBER	DOC TYPE	DOC PART	REVISION
SD-34897-001	PSD	000	W11

# MINI50 SMT DUAL ROW HEADER ASSEMBLIES

CIRCUIT	POL	COLOR	MATERIAL NUMBER		BLADE PLATING	FLAMMABILITY
			TUBE PACKAGING PK-31301-688	TAPE AND REEL PACKAGING PK-31301-786		
12	A	BLACK	34897-9120	34897-8120	TIN	HB
	B	GRAY	34897-9121	34897-8121	TIN	
	C	DARK GRAY	34897-9122	34897-8122	TIN	
16	A	BLACK	34897-9160	34897-8160	TIN	HB
	B	GRAY	34897-9161	34897-8161	TIN	
	C	DARK GRAY	34897-9162	34897-8162	TIN	
20	A	BLACK	34897-9200	34897-8200	TIN	HB
	B	GRAY	34897-9201	34897-8201	TIN	
	C	DARK GRAY	34897-9202	34897-8202	TIN	
24	A	BLACK	34897-9240	34897-8240	TIN	HB
	B	GRAY	34897-9241	34897-8241	TIN	
	C	DARK GRAY	34897-9242	34897-8242	TIN	
12	A	BLACK	215423-9120	215423-8120	TIN	V0
	B	GRAY	215423-9121	215423-8121	TIN	
	C	DARK GRAY	215423-9122	215423-8122	TIN	
16	A	BLACK	215423-9160	215423-8160	TIN	V0
	B	GRAY	215423-9161	215423-8161	TIN	
	C	DARK GRAY	215423-9162	215423-8162	TIN	
20	A	BLACK	215423-9200	215423-8200	TIN	V0
	B	GRAY	215423-9201	215423-8201	TIN	
	C	DARK GRAY	215423-9202	215423-8202	TIN	
24	A	BLACK	215423-9240	215423-8240	TIN	V0
	B	GRAY	215423-9241	215423-8241	TIN	
	C	DARK GRAY	215423-9242	215423-8242	TIN	
12	A	BLACK	34897-5120	34897-6120	GOLD	HB
	B	GRAY	34897-5121	34897-6121	GOLD	
	C	DARK GRAY	34897-5122	34897-6122	GOLD	
16	A	BLACK	34897-5160	34897-6160	GOLD	HB
	B	GRAY	34897-5161	34897-6161	GOLD	
	C	DARK GRAY	34897-5162	34897-6162	GOLD	
20	A	BLACK	34897-5200	34897-6200	GOLD	HB
	B	GRAY	34897-5201	34897-6201	GOLD	
	C	DARK GRAY	34897-5202	34897-6202	GOLD	
24	A	BLACK	34897-5240	34897-6240	GOLD	HB
	B	GRAY	34897-5241	34897-6241	GOLD	
	C	DARK GRAY	34897-5242	34897-6242	GOLD	
12	A	BLACK	215423-5120	215423-6120	GOLD	V0
	B	GRAY	215423-5121	215423-6121	GOLD	
	C	DARK GRAY	215423-5122	215423-6122	GOLD	
16	A	BLACK	215423-5160	215423-6160	GOLD	V0
	B	GRAY	215423-5161	215423-6161	GOLD	
	C	DARK GRAY	215423-5162	215423-6162	GOLD	
20	A	BLACK	215423-5200	215423-6200	GOLD	V0
	B	GRAY	215423-5201	215423-6201	GOLD	
	C	DARK GRAY	215423-5202	215423-6202	GOLD	
24	A	BLACK	215423-5240	215423-6240	GOLD	V0
	B	GRAY	215423-5241	215423-6241	GOLD	
	C	DARK GRAY	215423-5242	215423-6242	GOLD	

## MATING COMPONENTS

FOR ALL MATING COMPONENT PART NUMBERS SEE THE FOLLOWING SALES DRAWINGS

- GEN I RECEPTACLE ONLY: SD-34824-002
- GEN I RECEPTACLE WITH CPA: SD-34824-003
- GEN II: 2065230000

THIS DRAWING CONTAINS INFORMATION THAT IS PROPRIETARY TO MOLEX ELECTRONIC TECHNOLOGIES, LLC AND SHOULD NOT BE USED WITHOUT WRITTEN PERMISSION										
DIMENSION UNITS	SCALE	CURRENT REV DESC:			<b>molex</b>					
mm	1:1									
GENERAL TOLERANCES (UNLESS SPECIFIED)		EC NO: 659285			MINI50 12-24CKT SMT HDR SALES DRAWING					
ANGULAR TOL	± 1.0°	DRWN: SRUSS 2021/03/16								
4 PLACES	±	CHK'D: KHEWITT 2021/03/25			PRODUCT CUSTOMER DRAWING					
3 PLACES	±	APPR: JDUNAJ 2021/03/25								
2 PLACES	± 0.1	INITIAL REVISION:			DOCUMENT NUMBER					
1 PLACE	± 0.2	DRWN: SMAHESHBABU 2017/03/20								SD-34897-001
0 PLACES	±	APPR: KHEWITT 2017/06/21			DOC TYPE					
DRAFT WHERE APPLICABLE MUST REMAIN WITHIN DIMENSIONS		THIRD ANGLE PROJECTION	DRAWING	SERIES						CUSTOMER
			D-SIZE	34897	GENERAL MARKET			5 OF 5		