

## USRP™ N200/N210 NETWORKED SERIES



### FEATURES:

- Use with GNU Radio, LabVIEW™ and Simulink™
- Modular Architecture: DC-6 GHz
- Dual 100 MS/s, 14-bit ADC
- Dual 400 MS/s, 16-bit DAC
- DDC/DUC with 25 mHz Resolution
- Up to 50 MS/s Gigabit Ethernet Streaming
- Fully-Coherent MIMO Capability
- Gigabit Ethernet Interface to Host
- 2 Gbps Expansion Interface
- Spartan 3A-DSP 1800 FPGA (N200)
- Spartan 3A-DSP 3400 FPGA (N210)
- 1 MB High-Speed SRAM
- Auxiliary Analog and Digital I/O
- 2.5 ppm TCXO Frequency Reference
- 0.01 ppm w/ GPSDO Option

### N200/N210 PRODUCT OVERVIEW:

The Ettus Research™ USRP™ N200 and N210 are the highest performing class of hardware of the USRP™ (Universal Software Radio Peripheral) family of products, which enables engineers to rapidly design and implement powerful, flexible software radio systems. The N200 and N210 hardware is ideally suited for applications requiring high RF performance and great bandwidth. Such applications include physical layer prototyping, dynamic spectrum access and cognitive radio, spectrum monitoring, record and playback, and even networked sensor deployment.

The Networked Series products offers MIMO capability with high bandwidth and dynamic range. The Gigabit Ethernet interface serves as the connection between the N200/N210 and the host computer. This enables the user to realize 50 MS/s of real-time bandwidth in the receive and transmit directions, simultaneously (full duplex).

The Networked Series MIMO connection is located on the front panel of each unit. Two Networked Series units may be connected to realize a complete 2x2 MIMO configuration using the optional MIMO cable. External PPS and reference inputs can also be used to create larger multi-channel systems. The N200 and N210 are largely the same, except that the N210 features a larger FPGA for customers that intend to integrate custom FPGA functionality.

The USRP Hardware Driver™ is the official driver for all Ettus Research products. The USRP Hardware Driver supports Linux, Mac OSX, Windows.

# USRP™ N200/N210 NETWORKED SERIES

## SPECIFICATIONS

Spec	Typ.	Unit	Spec	Typ.	Unit
<b>POWER</b>			<b>RF PERFORMANCE (W/ WBX)</b>		
DC Input	6	V	SSB/LO Suppression	35/50	dBc
Current Consumption	1.3	A	Phase Noise (1.8 GHz)		
w/ WBX Daughterboard	2.3	A	10 kHz	-80	dBc/Hz
<b>CONVERSION PERFORMANCE AND CLOCKS</b>			100 kHz	-100	dBc/Hz
ADC Sample Rate	100	MS/s	1 MHz	-137	dBc/Hz
ADC Resolution	14	bits	Power Output	15	dBm
ADC Wideband SFDR	88	dBc	IIP3	0	dBm
DAC Sample Rate	400	MS/s	Receive Noise Figure	5	dB
DAC Resolution	16	bits	<b>PHYSICAL</b>		
DAC Wideband SFDR	80	dBc	Operating Temperature	0 to 55°	C
Host Sample Rate (8b/16b)	50/25	MS/s	Dimensions (l x w x h)	22 x 16 x 5	cm
Frequency Accuracy	2.5	ppm	Weight	1.2	kg
w/ GPSDO Reference	0.01	ppm			

\* All specifications are subject to change without notice.

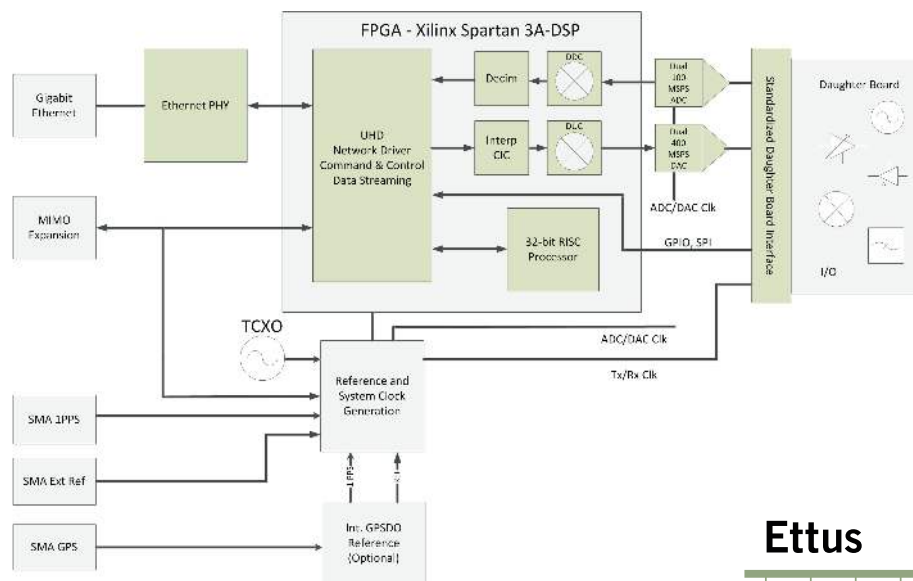

## ABOUT ETTUS RESEARCH:

Ettus Research is an innovative provider of software defined radio hardware, including the original Universal Software Radio Peripheral (USRP) family of products. Ettus Research products maintain support from a variety of software frameworks, including GNU Radio. Ettus Research is a leader in the GNU Radio open-source community, and enables users worldwide to address a wide range of research, industry and defense applications. The company was founded in 2004 and is based in Mountain View, California. As of 2010, Ettus Research is a wholly owned subsidiary of National Instruments.

1043 North Shoreline Blvd  
Suite 100  
Mountain View, CA 94043

P 650.967.2870 [www.ettus.com](http://www.ettus.com)  
F 866.807.9801