

Single chip ultra low power wireless

Ultra low power wireless system-on-chip solution

The nRF24LE1 OTP is a unique solution offering a complete ultra low power (ULP) wireless system-on-chip (SoC) solution. It integrates the industry best nRF24L01+ 2.4GHz transceiver core, an enhanced 8051 microcontroller, OTP memory and a wide range of analog and digital peripherals.

Block diagram

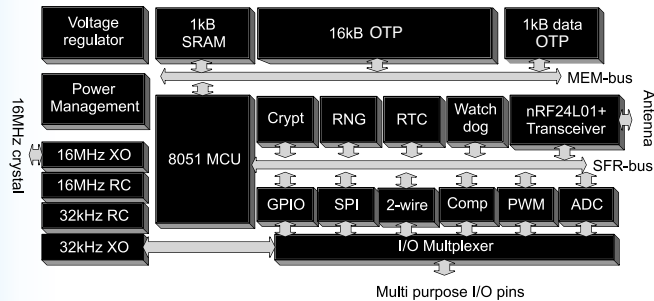

The 8-bit microcontroller is powerful enough to run both the RF protocol stack and the application layer, enabling a true single chip implementation of ULP wireless applications.

System diagram

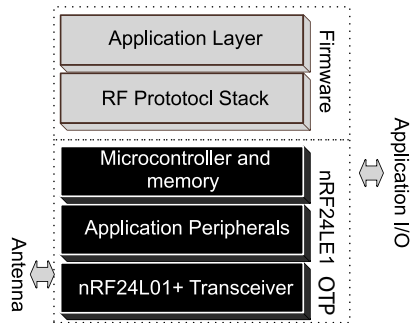

Optimized for ultra low power wireless

Advanced power management and on-chip peripherals

The nRF24LE1 OTP is optimized to provide a single chip solution for ULP wireless applications. The combination of processing power, memory, low power oscillators, real-time counter, AES encryption accelerator, random generator, plus a range of power saving modes provides an ideal platform for implementation of RF Protocols. Benefits include tighter protocol timing, security, lower power consumption and improved co-existence performance. For the application layer the nRF24LE1 offers a rich set of peripherals including: SPI, 2-wire, UART, 6 to 12-bit ADC, PWM, and an ultra low power analog comparator for voltage level system wake-up.

Three package sizes for different applications

Same core but different package and I/O count

The nRF24LE1 OTP comes in three different package variants:

- An ultra compact 4x4mm 24-pin QFN (7 generic I/O pins)
- A compact 5x5mm 32-pin QFN (15 generic I/O pins)
- A 7x7mm 48-pin QFN (29 generic I/O pins)

The 4x4mm 24-pin QFN with 7 generic I/O pins is ideal for low I/O count applications where small size is key. Examples include wearable sports sensors and watches. The 5x5mm 32-pin QFN with 15 generic I/O pins is ideal for medium I/O count applications such as wireless mice, remote controls and toys. The 7x7mm 48-pin QFN with 29 generic I/O pins is for high I/O count products like wireless keyboards



RF Silicon

Software

Reference Design

Development Tools

PRODUCT BRIEF

nRF24LE1 OTP

nRF24LE1-O17Q24
nRF24LE1-O17Q32
nRF24LE1-O17Q48

Low cost ultra low power wireless system-on-chip solutions with OTP memory

KEY FEATURES

- Fully featured ultra low power nRF24L01+ 2.4GHz transceiver core
- Worldwide 2.4GHz ISM band operation
- Enhanced ShockBurst™ hardware link layer
- 250 kbps, 1 Mbps and 2 Mbps on-air data rate options
- Air compatible with nRF24L01; nRF24L01+; nRF24LU1; nRF24LU1+, nRF24LE1 and nRF2401A, -02, -E1 and -E2
- Low cost external ±60ppm 16MHz crystal
- Enhanced 8-bit 8051 compatible microcontroller
- 32-bit multiplication-division unit
- AES encryption/decryption accelerator
- 16 kbytes on-chip OTP memory
- 1 kbyte on-chip data OTP memory
- 1 kbytes on SRAM plus 256 bytes of IRAM
- Low power 16MHz crystal and RC oscillators
- Ultra low power 32kHz crystal and RC oscillators
- Flexible real-time counter and three 16-bit timers/counters
- Ultra low power analog comparator for system wake-up
- Rich set of digital interfaces including: SPI master/slave, 2-wire master/slave, and UART
- 2-channel PWM
- Programmable resolution ADC: 6, 8, 10, or 12-bits
- Random Number Generator based on thermal noise
- Supports the Nordic nRFProbe hardware debugger (for flash development version)
- Programmable generic I/O pins
- Three package options:
 - 4x4mm 24-pin QFN (7 Generic I/O pins)
 - 5x5mm 32-pin QFN (15 Generic I/O pins)
 - 7x7mm 48-pin QFN (29 Generic I/O pins)

APPLICATIONS

- PC peripherals – mice, keyboards and remotes
- Gaming controllers
- RF remote controls for consumer electronics devices such as set-top boxes, media players and TVs
- Sports and healthcare sensors
- Sport watches, bike computers, and gym equipment
- Remote controlled toys
- Active RFID

A complete development platform

For firmware and hardware engineers

The nRF24LE1 OTP is supported by a complete development platform enabling designers to easily develop hardware and firmware for the chip. The platform comprises three key elements: the nRFgo Starter Kit, the nRF24LE1 Development Kit (flash version) and the nRFgo Flash/OTP Programming Adapter Kit.



nRFgo Starter Kit



nRF24LE1 Development Kit

The development kit for the nRF24LE1 OTP is the same as for the nRF24LE1 (flash version), documentation is available on how to develop firmware on the flash version that works on the nRF24LE1 OTP. The nRFgo Flash/OTP Programming Adapter Kit is a plug-in for the nRFgo Starter Kit that enables both programming of blank un-mounted and mounted nRF24LE1 OTP parts.

For more information

Please visit www.nordicsemi.com for the complete product specification and more information about this or any other ULP wireless products.

About Nordic Semiconductor ASA

Ultra low power RF silicon solutions

Nordic Semiconductor is a fabless semiconductor company specializing in ULP short-range wireless communication. Nordic is a public company listed on the Norwegian stock exchange.

Nordic provides RF Silicon Solutions for ultra low power wireless including:

- Highly integrated RF silicon
- Sophisticated and flexible development tools
- Application specific communication software
- Complete reference designs

Worldwide office locations

Headquarter

Trondheim, Norway

Telephone: +47 72 89 89 00

www.nordicsemi.com

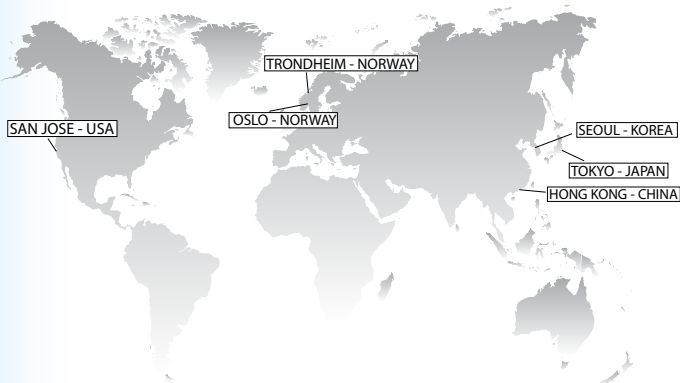

SPECIFICATIONS

| | |
|-----------------------|---|
| Frequency band | 2.4GHz ISM (2.40000 – 2.4835GHz) |
| On-air data rate | 250 kbps, 1 Mbps or 2 Mbps |
| Modulation | GFSK |
| RF channel resolution | 1MHz |
| RF channels | 79 within the 2.4GHz ISM band |
| Output power | Programmable: 0, -6, -12 or -18 dBm |
| External crystal | 16MHz ±60ppm |
| Hardware Link layer | Enhanced ShockBurst™ |
| Microcontroller | Enhanced 8-bit 8051 compatible microcontroller <ul style="list-style-type: none"> - Reduced instruction cycle time - Up to 16MHz operation - 32-bit multiplication/division unit |
| Program Memory | 17 kbytes OTP |
| Data memory | 1 kbytes OTP |
| RAM | 1 kbytes SRAM plus 256 bytes IRAM |
| Oscillators | 16MHz crystal oscillator 16MHz RC oscillator 32kHz crystal oscillator 32kHz RC oscillator |
| Hardware Security | 8 x 8 Gaolis field multiplier for AES acceleration |
| Digital I/O | Flexible general purpose data port <ul style="list-style-type: none"> - Hardware SPI master/slave - 2-wire master/slave - UART |
| Analog peripherals | Programmable resolution ADC 2-channel PWM Analog comparator Random Number Generator |
| General purpose I/O | 7 for 24-pin 4x4mm variant 15 for 32-pin 5x5mm variant 29 for 48-pin 7x7mm variant |
| Voltage regulator | On-chip 1.9 to 3.6V operation |
| Package options | RoHS compliant 24-pin 4x4mm QFN (nRF24LE1-F16Q24) 32-pin 5x5mm QFN (nRF24LE1-F16Q32) 48-pin 7x7mm QFN (nRF24LE1-F16Q48) |

Related Products

| | |
|--------------------|--|
| nRF6700 | nRFgo Starter Kit |
| nRF24LE1-F17Qxx-DK | nRFgo Development Kit for nRF24LE1 (Flash based) |
| nRF6701/2/3 | nRFgo Flash/OTP programming Adaptor Kit for nRF24LE1 OTP |
| nRF24LE1-F16Qxx | flash variant of this chip |

Visit www.nordicsemi.com for Nordic Semiconductor sales offices and distributors worldwide.