

Dual Channel Encoder

Type OPB950

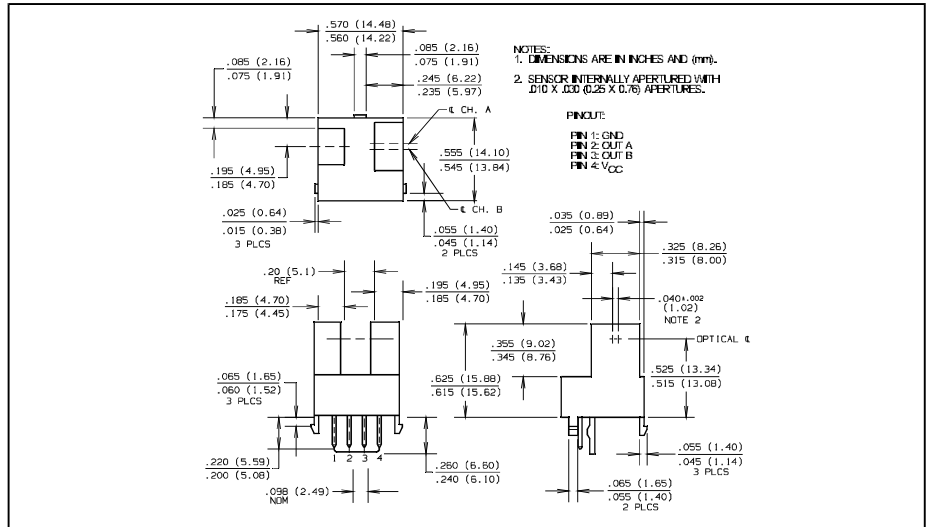
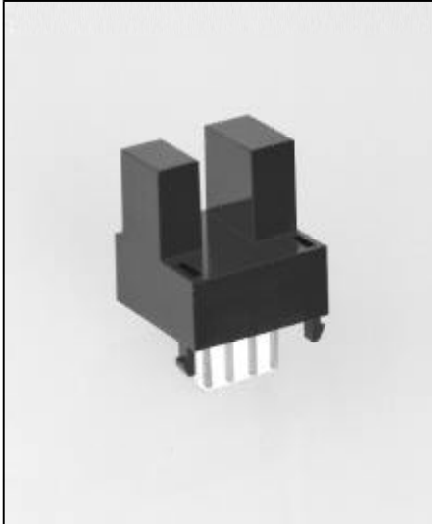

Features

- Dual channel outputs
- 0.010" (0.254 mm) sensor apertures for high resolution
- Open collector inverter outputs
- Snap mount
- 4-pin connector
0.98" (2.5 mm)
Mates with Molex 22-01-1042 and terminal # 08-70-0069

Description

The OPB950 consists of an infrared emitting diode and a monolithic integrated circuit which incorporates two independent photodiodes, linear amplifiers, Schmitt trigger circuits and output transistors. The outputs are TTL/LSTTL compatible and can drive 8 TTL loads.

Applications include linear and rotary encoders with high resolution provided by internal 0.010" (0.254 mm) apertures located in front of Photologic® sensor on 0.040" (1.02 mm) center line spacing.



For RoHS compliant devices add "Z" to the end of the part number: OPB950Z

RoHS

Absolute Maximum Ratings (T_A = 25° C unless otherwise noted)

Storage Temperature Range -40° C to +85° C
 Operating Temperature Range -40° C to +85° C

Input Diode

Forward DC Current 50 mA
 Peak Forward Current (1μs Pulse Width, 300 pps) 3.0 A
 Reverse D. C. Voltage 2.0 V
 Power Dissipation 100 mW⁽¹⁾

Output Photologic®

Supply Voltage, V_{CC} 5 V
 Voltage at Output 18 V
 Power Dissipation 200 mW⁽²⁾
 Low Level Output Current (Sinking) 40 mA

Notes:

- (1) Derate linearly 1.67 mW/° C above 25° C.
 (2) Derate linearly 3.33 mW/° C above 25° C.

Schematic

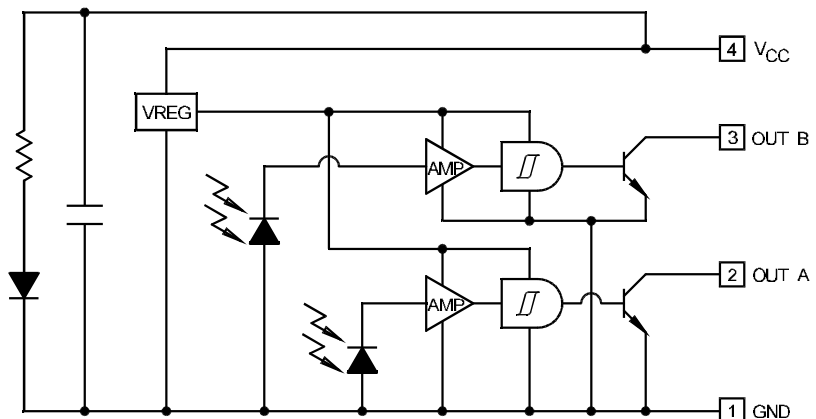

Type OPB950

Electrical Characteristics ($T_A = 25^\circ\text{C}$ unless otherwise noted)

SYMBOL	PARAMETER	MIN	TYP	MAX	UNITS	TEST CONDITIONS
V_{CC}	Operating D.C. Supply Voltage	4.75	5.0	5.25	V	
V_{OH}	High Level Output Voltage (per channel)	2.4			V	$V_{CC} = 5.0\text{ V}$, Blocked Condition
V_{OL}	Low Level Output Voltage (per channel)			0.4	V	$V_{CC} = 5.0\text{ V}$, Unblocked Condition