

REVISIONS

P	LTR	DESCRIPTION	DATE	DWN	APVD
D1		ECO-20-004274	17MAR2021	RK	DR

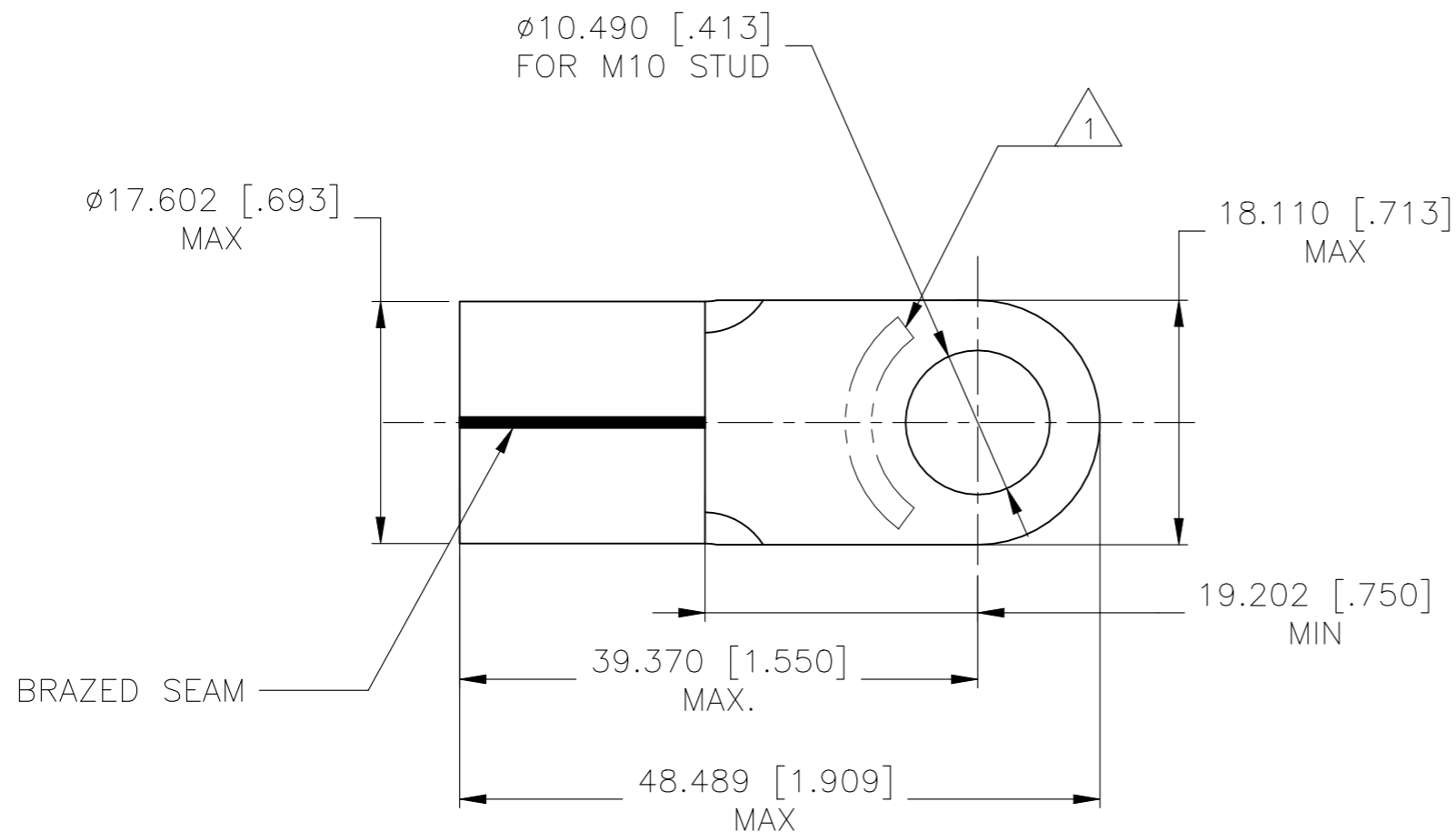

- 1 STAMP: AMP 2/0 W* APPROX AS SHOWN.
- 2 MATERIAL: COPPER PER ASTM B152.
- 3 FINISH: NICKEL PLATE 0.00762 [.000300] MIN EXT THK PER SAE AMS QQ-N-290.

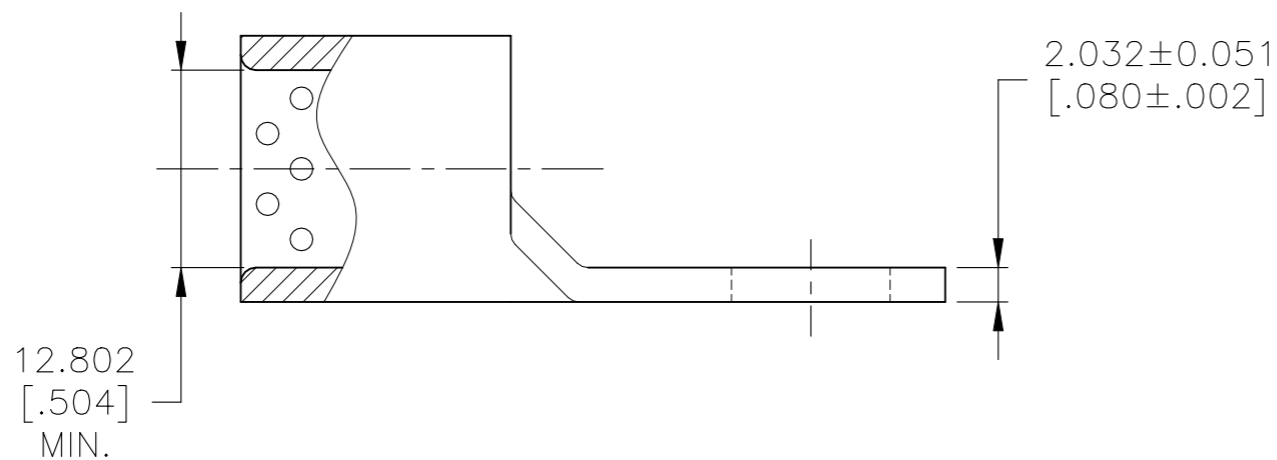

50	LOOSE PIECE	134755-2
QTY	PACKAGE TYPE	PART NUMBER

MAX. TEMP: 343°C [649°F]	THIS DRAWING IS A CONTROLLED DOCUMENT.		DWN A.DUPOUIS 28/01/91	TE Connectivity TERMINAL, RING TONGUE, STRATO-THERM, HEAT RESISTANT, WIRE SIZE: 2/0 AWG		
	VOLTAGE RATING: N/A	DIMENSIONS: mm [INCHES]	TOLERANCES UNLESS OTHERWISE SPECIFIED:			
CIRCULAR MIL AREA: 60.6-76.3 MM ² [119,500-150,500] SOLID OR STRAUNDED	MATERIAL 2	FINISH 3	0 PLC ± -	APVD	NAME	
			1 PLC ± -	PRODUCT SPEC		
			2 PLC ± -	APPLICATION SPEC	SIZE	
			3 PLC ± 0.127[.005]	114-2162	CAGE CODE	
			4 PLC ± -	WEIGHT	DRAWING NO	
			ANGLES ± -		A3 00779 C-134755	
			FINISH	RESTRICTED TO		
				CUSTOMER DRAWING		
				SCALE	SHEET	
				2:1	1 OF 1	
				REV	D1	