



TABLE OF CONTENTS

1. GENERAL DESCRIPTION	3
2. FEATURES	3
3. ORDERING INFORMATION	3
4. PIN CONFIGURATION	4
4.1 Ball Assignment	4
5. PIN DESCRIPTION	5
5.1 Signal Description	5
6. BLOCK DIAGRAM	6
7. INSTRUCTION SET	7
7.1 Bus Operation	7
8. FUNCTIONAL DESCRIPTION	8
8.1 Power Up Initialization	8
8.1.1 Power-Up Initialization Timing	8
8.2 Bus Operating Modes	8
8.2.1 Asynchronous Modes	8
8.2.1.1 READ Operation (ADV# LOW)	9
8.2.1.2 WRITE Operation (ADV# LOW)	9
8.2.2 Burst Mode Operation	10
8.2.2.1 Burst Mode READ (4-word burst)	10
8.2.2.2 Burst Mode WRITE (4-word burst)	11
8.2.2.3 Refresh Collision During Variable-Latency READ Operation	12
8.2.3 Mixed-Mode Operation	13
8.2.4 WAIT Operation	13
8.2.4.1 Wired-OR WAIT Configuration	13
8.2.5 LB#/ UB# Operation	14
8.3 Low Power Operation	14
8.3.1 Standby Mode Operation	14
8.3.2 Temperature Compensated Refresh	14
8.3.3 Partial-Array Refresh	14
8.3.4 Deep Power-Down Operation	14
8.4 Registers	15
8.4.1 Access Using CRE	15
8.4.1.1 Configuration Register WRITE Asynchronous Mode Followed by READ Operation	15
8.4.1.2 Configuration Register WRITE Synchronous Mode Followed by READ Operation	16
8.4.1.3 Configuration Register READ Asynchronous Mode Followed by READ ARRAY Operation	17
8.4.1.4 Configuration Register READ Synchronous Mode Followed by READ ARRAY Operation	18
8.4.2 Software Access	19
8.4.2.1 Load Configuration Register	19
8.4.2.2 Read Configuration Register	20
8.4.3 Bus Configuration Register	20
8.4.3.1 Bus Configuration Register Definition	21
8.4.3.2 Burst Length (BCR[2:0]) Default = Continuous Burst	22
8.4.3.3 Burst Wrap (BCR[3]) Default = No Wrap	22
8.4.3.4 Sequence and Burst Length	23
8.4.3.5 Drive Strength (BCR[5:4]) Default = Outputs Use Half-Drive Strength	24
8.4.3.6 Table of Drive Strength	24
8.4.3.7 WAIT Configuration. (BCR[8])	24
8.4.3.8 WAIT Polarity (BCR[10])	24
8.4.3.9 WAIT Configuration During Burst Operation	25
8.4.3.10 Latency Counter (BCR[13:11]) Default = Three Clock Latency	25
8.4.3.11 Initial Access Latency (BCR[14]) Default = Variable	25
8.4.3.12 Allowed Latency Counter Settings in Variable Latency Mode	25



8.4.3.13 Latency Counter (Variable Initial Latency, No Refresh Collision).....	26
8.4.3.14 Allowed Latency Counter Settings in Fixed Latency Mode.....	26
8.4.3.15 Latency Counter (Fixed Latency).....	27
8.4.3.16 Operating Mode (BCR[15]).....	27
8.4.4 Refresh Configuration Register.....	28
8.4.4.1 Refresh Configuration Register Mapping.....	28
8.4.4.2 Partial Array Refresh (RCR[2:0]) Default = Full Array Refresh.....	28
8.4.4.3 Address Patterns for PAR (RCR [4] = 1).....	29
8.4.4.4 Deep Power-Down (RCR[4]) Default = DPD Disabled.....	29
8.4.5 Device Identification Register.....	29
8.4.5.1 Device Identification Register Mapping.....	29
8.4.5.2 Virtual Chip Enable Function:.....	29
9. ELECTRICAL CHARACTERISTIC.....	30
9.1 Absolute Maximum DC, AC Ratings.....	30
9.2 Electrical Characteristics and Operating Conditions.....	30
9.3 Deep Power-Down Specifications.....	31
9.4 Partial Array Self Refresh Standby Current.....	31
9.5 Capacitance.....	31
9.6 AC Input-Output Reference Wave form.....	31
9.7 AC Output Load Circuit.....	31
10. TIMING REQUIRMENTS.....	32
10.1 Read, Write Timing Requirements.....	32
10.1.1 Asynchronous READ Cycle Timing Requirements.....	32
10.1.2 Burst READ Cycle Timing Requirements.....	33
10.1.3 Asynchronous WRITE Cycle Timing Requirements.....	34
10.1.4 Burst WRITE Cycle Timing Requirements.....	35
10.2 TIMING DIAGRAMS.....	36
10.2.1 Initialization Period.....	36
10.2.2 DPD Entry and Exit Timing Parameters.....	36
10.2.3 Initialization and DPD Timing Parameters.....	36
10.2.4 Asynchronous READ.....	37
10.2.5 Single Access Burst READ Operation - Variable Latency.....	38
10.2.6 Four Word Burst READ Operation-Variable Latency.....	39
10.2.7 Single-Access Burst READ Operation-Fixed Latency.....	40
10.2.8 Four Word Burst READ Operation-Fixed Latency.....	41
10.2.9 Burst READ Terminate at End-of-Row (Wrap Off).....	42
10.2.10 Burst READ Row Boundary Crossing.....	43
10.2.11 Asynchronous WRITE.....	44
10.2.12 Burst WRITE Operation—Variable Latency Mode.....	45
10.2.13 Burst WRITE Operation-Fixed Latency Mode.....	46
10.2.14 Burst WRITE Terminate at End of Row (Wrap Off).....	47
10.2.15 Burst WRITE Row Boundary Crossing.....	48
10.2.17 Asynchronous WRITE Followed by Burst READ.....	50
10.2.18 Burst READ Followed by Asynchronous WRITE.....	51
10.2.19 Asynchronous WRITE Followed by Asynchronous READ.....	52
11. PACKAGE DESCRIPTION.....	53
11.1 Package Dimension.....	53
12. REVISION HISTORY.....	54



1. GENERAL DESCRIPTION

Winbond x16 ADMUX products are high-speed, CMOS pseudo-static random access memory developed for low-power, portable applications. The device has a DRAM core organized. These devices are a variation of the industry-standard Flash control interface, with a multiplexed address/data bus. The multiplexed address and data functionality dramatically reduce the required signal count, and increase READ/WRITE bandwidth.

For seamless operation on a burst Flash bus, Winbond x16 ADMUX products incorporate a transparent self-refresh mechanism. The hidden refresh requires no additional support from the system memory controller and has no significant impact on device READ/WRITE performance.

Two user-accessible control registers define device operation. The bus configuration register (BCR) defines how the Winbond x16 ADMUX device interacts with the system memory bus and is nearly identical to its counterpart on burst mode Flash devices. The refresh configuration register (RCR) is used to control how refresh is performed on the DRAM array. These registers are automatically loaded with default settings during power-up and can be updated anytime during normal operation.

Special attention has been focused on standby current consumption during self refresh. Winbond x16 ADMUX products include two mechanisms to minimize standby current. Partial-array refresh (PAR) enables the system to limit refresh to only that part of the DRAM array that contains essential data. Temperature-compensated refresh (TCR) uses an on-chip sensor to adjust the refresh rate to match the device temperature—the refresh rate decreases at lower temperatures to minimize current consumption during standby. The system-configurable refresh mechanisms are accessed through the RCR.

Winbond x16 ADMUX device is compliant with the industry-standard CellularRAM 1.5 x16 A/D MUX.

2. FEATURES

- | | |
|--|---|
| <ul style="list-style-type: none"> • Supports asynchronous, page, and burst operations • VCC, VCCQ Voltages:
1.7V–1.95V VCC
1.7V–1.95V VCCQ • Random access time: 70ns • Burst mode READ and WRITE access:
4, 8, 16, or 32 words, or continuous burst
Burst wrap or sequential
Max clock rate: 133 MHz (tCLK = 7.5ns) • Low power consumption:
Asynchronous READ: <25 mA
Continuous burst READ: <35 mA
Standby current: 400 μA | <ul style="list-style-type: none"> • Low-power features
On-chip temperature compensated refresh (TCR)
Partial array refresh (PAR)
Deep power-down (DPD) mode • Package: 54 Ball VFBGA • 16-bit multiplexed address/data bus • Operating temperature range:
-40°C \leq TCASE \leq 85°C |
|--|---|

3. ORDERING INFORMATION

Part Number	VDD/VDDQ	I/O Width	Type	Others
W958D6DBCX7I	1.8/1.8	x16	54VFBGA	CRAM A/D Mux, 133MHz, -40°C~85°C



4. PIN CONFIGURATION

4.1 Ball Assignment

	1	2	3	4	5	6
A	LB#	OE#	NC	NC	NC	CRE
B	ADQ8	UB#	NC	NC	CE#	ADQ0
C	ADQ9	ADQ10	NC	NC	ADQ1	ADQ2
D	VSSQ	ADQ11	A17	NC	ADQ3	VCC
E	VCCQ	ADQ12	A21	A16	ADQ4	VSS
F	ADQ14	ADQ13	NC	NC	ADQ5	ADQ6
G	ADQ15	A19	NC	NC	WE#	ADQ7
H	A18	NC	NC	NC	NC	A20
J	WAIT	CLK	ADV#	A22	A23	NC

(Top View) Pin Configuration



5. PIN DESCRIPTION

5.1 Signal Description

Symbol	Type	Description
A[max:16]	Input	Address inputs: Inputs for addresses during READ and WRITE operations. Addresses are internally latched during READ and WRITE cycles. The address lines are also used to define the value to be loaded into the BCR or the RCR. A[max:16]=A[23:16] (256Mb)
CLK (Note 1)	Input	Clock: Synchronizes the memory to the system operating frequency during synchronous operations. When configured for synchronous operation, the address is latched on the first rising CLK edge when ADV# is active. CLK must be static (HIGH or LOW) during asynchronous access READ and WRITE operations when burst mode is enabled.
ADV# (Note 1)	Input	Address valid: Indicates that a valid address is present on the address inputs. Addresses are latched on the rising edge of ADV# during asynchronous READ and WRITE operations.
CRE	Input	Control register enable: When CRE is HIGH, WRITE operations load the RCR or BCR, and READ operations access the RCR, BCR, or DIDR.
CE#	Input	Chip enable: Activates the device when LOW. When CE# is HIGH, the device is disabled and goes into standby mode.
OE#	Input	Output enable: Enables the output buffers when LOW. When OE# is HIGH, the output buffers are disabled.
WE#	Input	Write enable: Determines if a given cycle is a WRITE cycle. If WE# is LOW, the cycle is a WRITE to either a configuration register or to the memory array.
LB#	Input	Lower byte enable: DQ[7:0]
UB#	Input	Upper byte enable: DQ[15:8]
A/DQ[15:0]	Input / Output	Address/data I/Os: These pins are a multiplexed address/data bus. As inputs for addresses, these pins behave as A[15:0]. A[0] is the LSB of the 16-bit word address within the CellularRAM device. Address, RCR, and BCR values are loaded with ADV# LOW. Data is input or output when ADV# is HIGH.
WAIT (Note 1)	Output	WAIT: Provides data-valid feedback during burst READ and WRITE operations. WAIT is used to arbitrate collisions between refresh and READ/WRITE operations. WAIT is also asserted at the end of a row unless wrapping within the burst length. WAIT should be ignored during asynchronous operations. WAIT is High-Z when CE# is HIGH.
NC	—	Reserved for future use.
VCC	Supply	Device power supply: (1.70V–1.95V) Power supply for device core operation.
VCCQ	Supply	I/O power supply: (1.70V–1.95V) Power supply for input/output buffers.
VSS	Supply	VSS must be connected to ground.
VSSQ	Supply	VSSQ must be connected to ground.

Note:

1. When using asynchronous mode exclusively, CLK can be tied to VSSQ or VCCQ. WAIT should be ignored during asynchronous mode operations.



6. BLOCK DIAGRAM

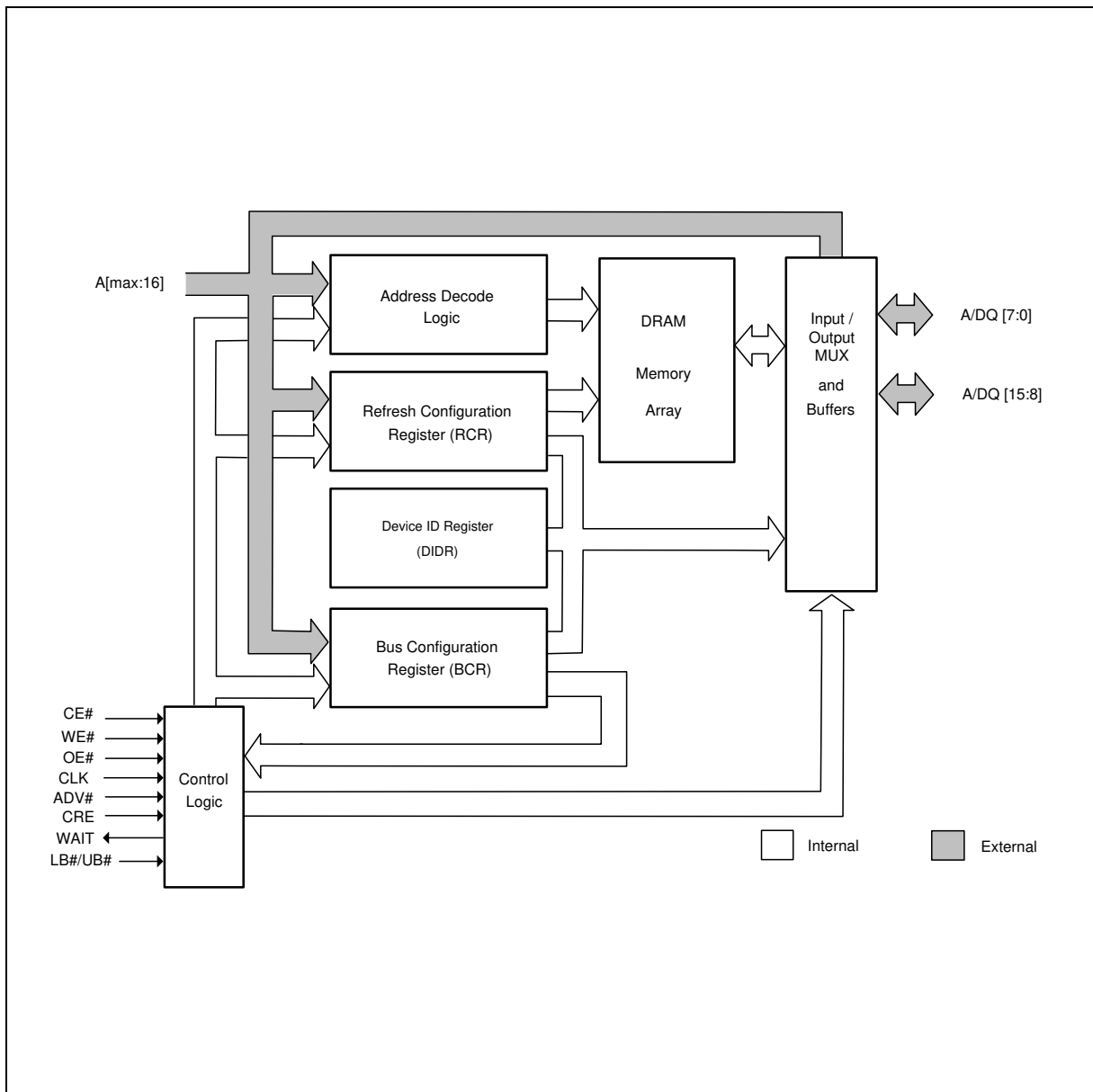



7. INSTRUCTION SET

7.1 Bus Operation

Asynchronous Mode BCR[15] = 1 (default)	Power	CLK	ADV#	CE#	OE#	WE#	CRE	LB#/ UB#	WAIT*2	A/DQ[15:0]*3	Notes
Read	Active	X	$\uparrow\uparrow$	L	L	H	L	L	Low-Z	Data out	4
Write	Active	X	$\uparrow\uparrow$	L	X	L	L	L	High-Z	Data in	4
Standby	Standby	H or L	X	H	X	X	L	X	High-Z	High-Z	5, 6
No operation	Idle	X	X	L	X	X	L	X	Low-Z	X	4, 6
Configuration register WRITE	Active	X	$\uparrow\uparrow$	L	H	L	H	X	Low-Z	High-Z	
Configuration register READ	Active	x	$\uparrow\uparrow$	L	L	H	H	L	Low-Z	Config. reg. out	
DPD	Deep power-down	X	X	H	X	X	X	X	High-Z	High-Z	10
Burst Mode BCR[15] = 0	Power	CLK*1	ADV#	CE#	OE#	WE#	CRE	LB#/ UB#	WAIT*2	A/DQ[15:0]*3	Notes
Read	Active	H or L	$\uparrow\uparrow$	L	L	H	L	L	Low-Z	Data out	4, 7
Write	Active	H or L	$\uparrow\uparrow$	L	X	L	L	L	High-Z	Data in	4
Standby	Standby	H or L	X	H	X	X	L	X	High-Z	High-Z	5, 6
No operation	Idle	H or L	X	L	X	X	L	X	Low-Z	X	4, 6
Initial burst READ	Active	$\uparrow\downarrow$	L	L	X	H	L	L	Low-Z	Address	4, 8
Initial burst WRITE	Active	$\uparrow\downarrow$	L	L	H	L	L	X	Low-Z	Address	4, 8
Burst continue	Active	$\uparrow\downarrow$	H	L	X	X	X	L	Low-Z	Data in or Data out	4, 8
Configuration register WRITE	Active	$\uparrow\downarrow$	L	L	H	L	H	X	Low-Z	High-Z	8, 9
Configuration register READ	Active	$\uparrow\downarrow$	L	L	L	H	H	L	Low-Z	Config. reg. out	8, 9
DPD	Deep power-down	L	X	H	X	X	X	X	High-Z	High-Z	10

Notes:

1. With burst mode enabled, CLK must be static (HIGH or LOW) during asynchronous READs and asynchronous WRITEs and to achieve standby power during standby and DPD modes.
2. The WAIT polarity is configured through the bus configuration register (BCR[10]).
3. When LB# and UB# are in select mode (LOW), DQ[15:0] are enabled. When only LB# is in select mode, DQ[7:0] are enabled. When only UB# is in the select mode, DQ[15:8] are enabled.
4. The device will consume active power in this mode whenever addresses are changed.
5. When the device is in standby mode, address inputs and data inputs/outputs are internally isolated from any external influence.
6. VIN = VCCQ or 0V; all device balls must be static (unswitched) in order to achieve standby current.
7. When the BCR is configured for synchronous mode, synchronous READ and WRITE and asynchronous WRITE and READ are supported.
8. Burst mode operation is initialized through the bus configuration register (BCR[15])
9. Initial cycle. Following cycles are the same as BURST CONTINUE. CE# must stay LOW for the equivalent of a single-word burst (as indicated by WAIT).
10. DPD is initiated when CE# transitions from LOW to HIGH after writing RCR[4] to 0. DPD is maintained until CE# transitions from HIGH to LOW.



8. FUNCTIONAL DESCRIPTION

In general, ADMUX PSRAM devices are high-density alternatives to SRAM and Pseudo SRAM products, popular in low-power, portable applications. Both devices implement a multiplexed address/data bus. This multiplexed configuration supports greater bandwidth through the x16 data bus, yet still reduces the required signal count. The ADMUX PSRAM bus interface supports both asynchronous and burst mode transfers.

8.1 Power Up Initialization

ADMUX PRAM products include an on-chip voltage sensor used to launch the power-up initialization process. Initialization will configure the BCR and the RCR with their default settings. VCC and VCCQ must be applied simultaneously. When they reach a stable level at or above 1.7V, the device will require 150 μ s to complete its self-initialization process. During the initialization period, CE# should remain HIGH. When initialization is complete, the device is ready for normal operation.

8.1.1 Power-Up Initialization Timing

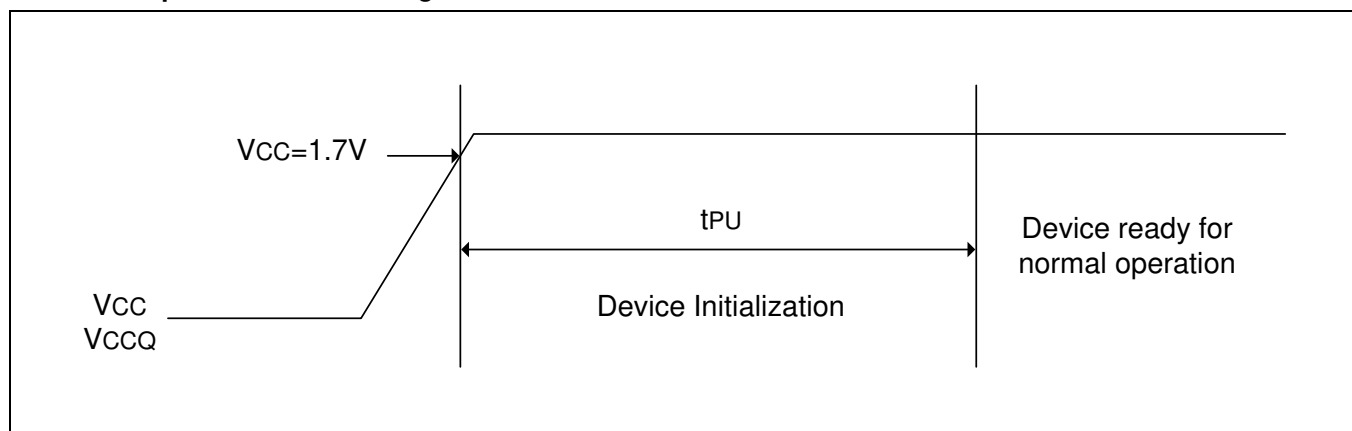

8.2 Bus Operating Modes

This asynchronous/burst ADMUX PSRAM products incorporate a burst mode interface found on Flash products targeting low-power, wireless applications. This bus interface supports asynchronous, and burst mode read and write transfers. The specific interface supported is defined by the value loaded into the BCR.

8.2.1 Asynchronous Modes

Using industry-standard SRAM control signals (CE#, ADV#, OE#, WE#, and LB#/UB#). READ operations are initiated by bringing CE#, ADV#, and LB#/UB# LOW while keeping OE# and WE# HIGH, and driving the address onto the A/DQ bus. ADV# is taken HIGH to capture the address, and OE# is taken LOW. Valid data will be driven out of the I/Os after the specified access time has elapsed.

WRITE operations occur when CE#, ADV#, WE#, and LB#/UB# are driven LOW with the address on the A/DQ bus. ADV# is taken HIGH to capture the address, then the WRITE data is driven onto the bus. During asynchronous WRITE operations, the OE# level is a "Don't Care," and WE# will override OE#; however, OE# must be HIGH while the address is driven onto the A/DQ bus. The data to be written is latched on the rising edge of CE#, WE#, UB#, or LB# (whichever occurs first).

During asynchronous operation with burst mode enabled, the CLK input must be held static (LOW). WAIT will be driven during asynchronous READs, and its state should be ignored. WE# LOW time must be limited to tCEM.



8.2.1.1 READ Operation (ADV# LOW)

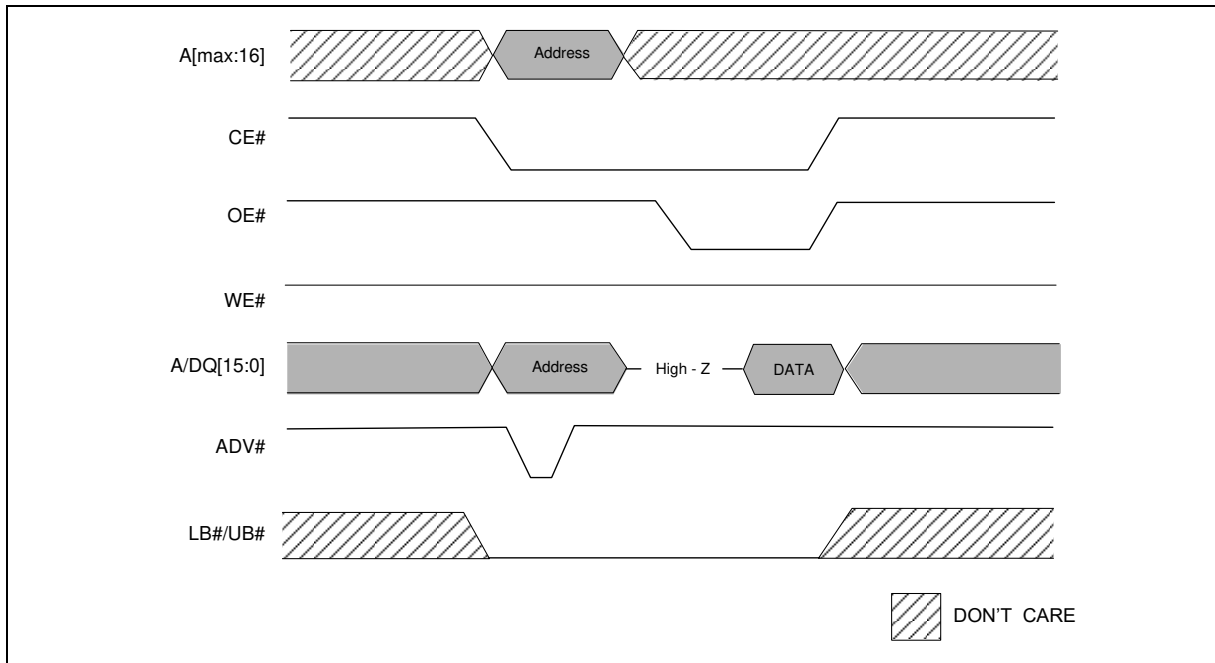

8.2.1.2 WRITE Operation (ADV# LOW)

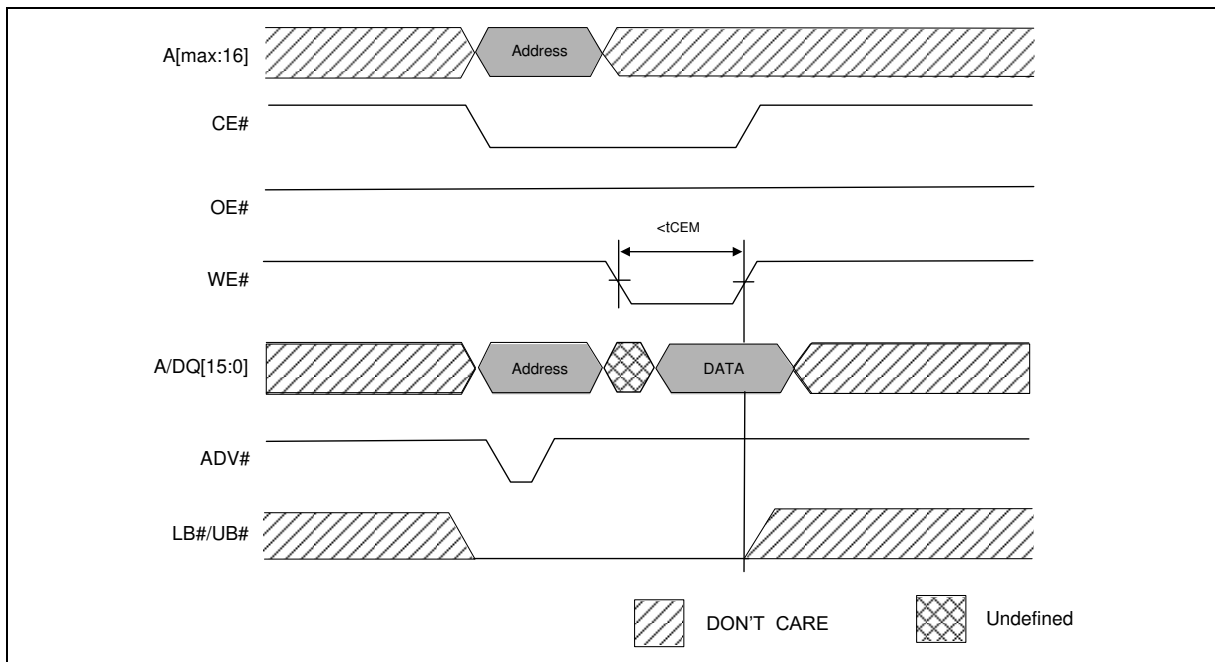



8.2.2 Burst Mode Operation

Burst mode operations enable high-speed synchronous READ and WRITE operations. Burst operations consist of a multi-clock sequence that must be performed in an ordered fashion. After CE# goes LOW; the address to access is latched on the first CLK edge after ADV# LOW. During this first clock rising edge, WE# indicates whether the operation is going to be a READ (WE# = HIGH) or WRITE (WE# =LOW).

8.2.2.1 Burst Mode READ (4-word burst)

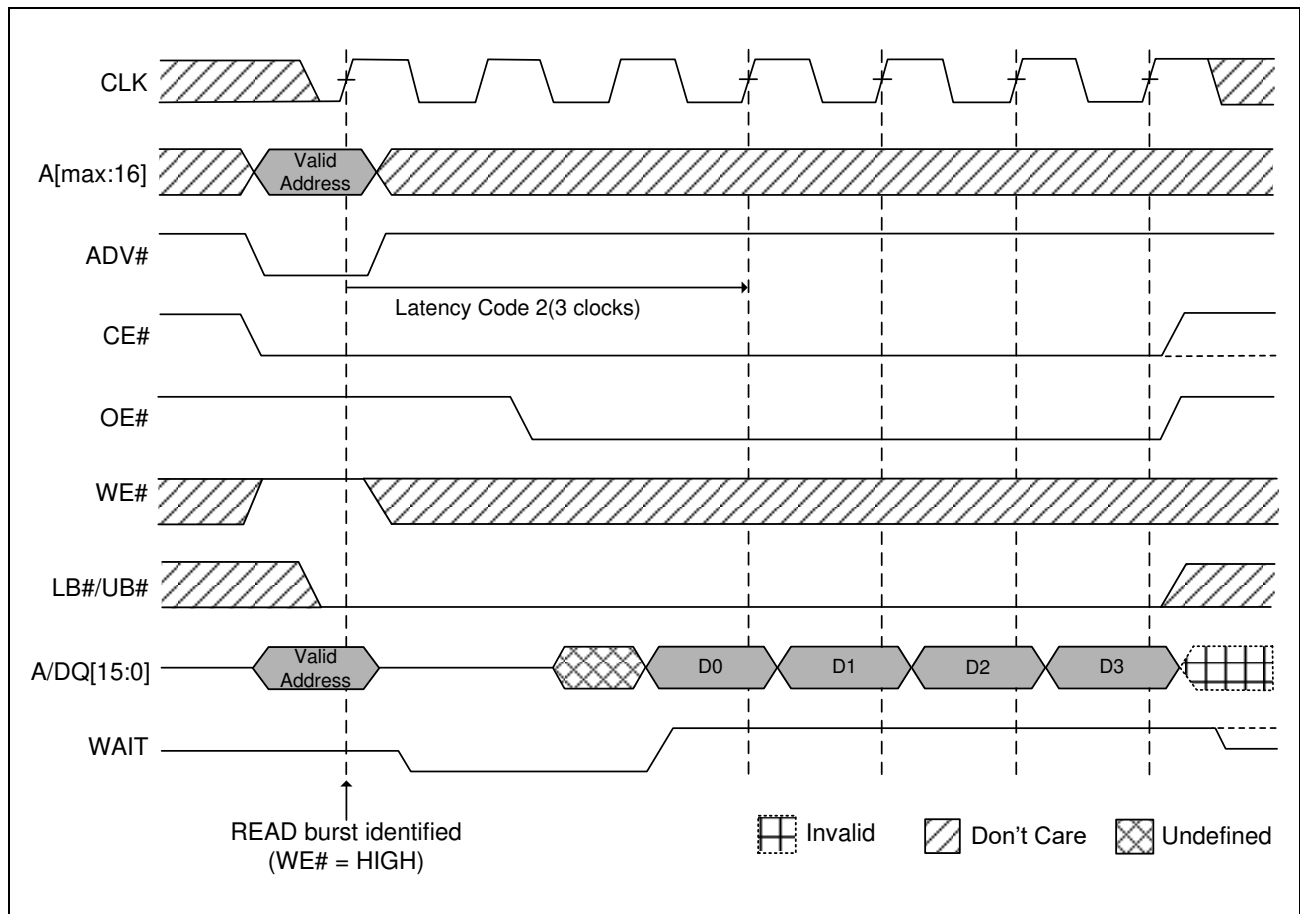

Note:

Non-default BCR settings for burst mode READ (4-word burst): fixed or variable latency, Latency code 2 (3 clocks), WAIT active Low, WAIT asserted during delay. Diagram is representative of variable latency with no refresh collision or fixed-latency access.



8.2.2.2 Burst Mode WRITE (4-word burst)

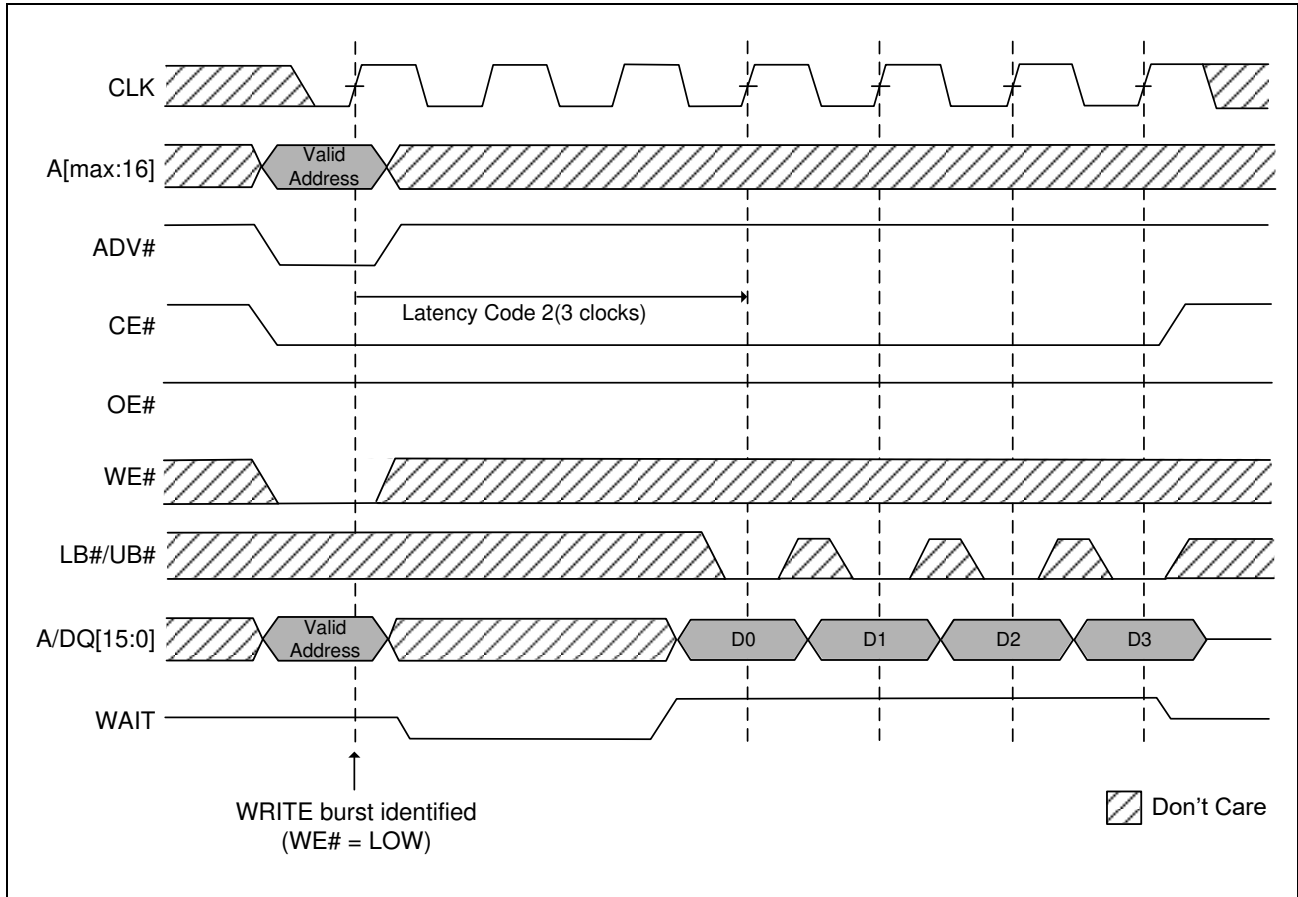

Note:

Non-default BCR settings for burst mode WRITE (4-word burst): fixed or variable latency, latency code 2 (3 clocks), WAIT active LOW, WAIT asserted during delay.



The size of a burst can be specified in the BCR either as a fixed length or continuous. Fixed-length bursts consist of 4, 8, 16, or 32 words. Continuous bursts have the ability to start at a specified address and burst to the end of the address. It goes back to the first address and continues to burst when continuous bursts meet the end of address.

The latency count stored in the BCR defines the number of clock cycles that elapse before the initial data value is transferred between the processor and ADMUX PSRAM device. The initial latency for READ operations can be configured as fixed or variable (WRITE operations always use fixed latency). Variable latency allows the ADMUX PSRAM to be configured for minimum latency at high clock frequencies, but the controller must monitor WAIT to detect any conflict with refresh cycles.

Fixed latency outputs the first data word after the worst-case access delay, including allowance for refresh collisions. The initial latency time and clock speed determine the latency count setting. Fixed latency is used when the controller cannot monitor WAIT. Fixed latency also provides improved performance at lower clock frequencies.

The WAIT output asserts when a burst is initiated, and de-asserts to indicate when data is to be transferred into (or out of) the memory. WAIT will again be asserted at the boundary of the row, unless wrapping within the burst length. With wrap off, the ADMUX PSRAM device will restore the previous row's data and access the next row, WAIT will be de-asserted, and the burst can continue across the row boundary. If the burst is to terminate at the row boundary, CE# must go HIGH within 2 clocks of the last data. CE# must go HIGH before any clock edge following the last word of a defined-length burst WRITE.

The CE# LOW time is limited by refresh considerations. CE# must not stay LOW longer than tCEM. If a burst suspension will cause CE# to remain LOW for longer than tCEM, CE# should be taken HIGH and the burst restarted with a new CE# LOW/ADV# LOW cycle.

8.2.2.3 Refresh Collision During Variable-Latency READ Operation

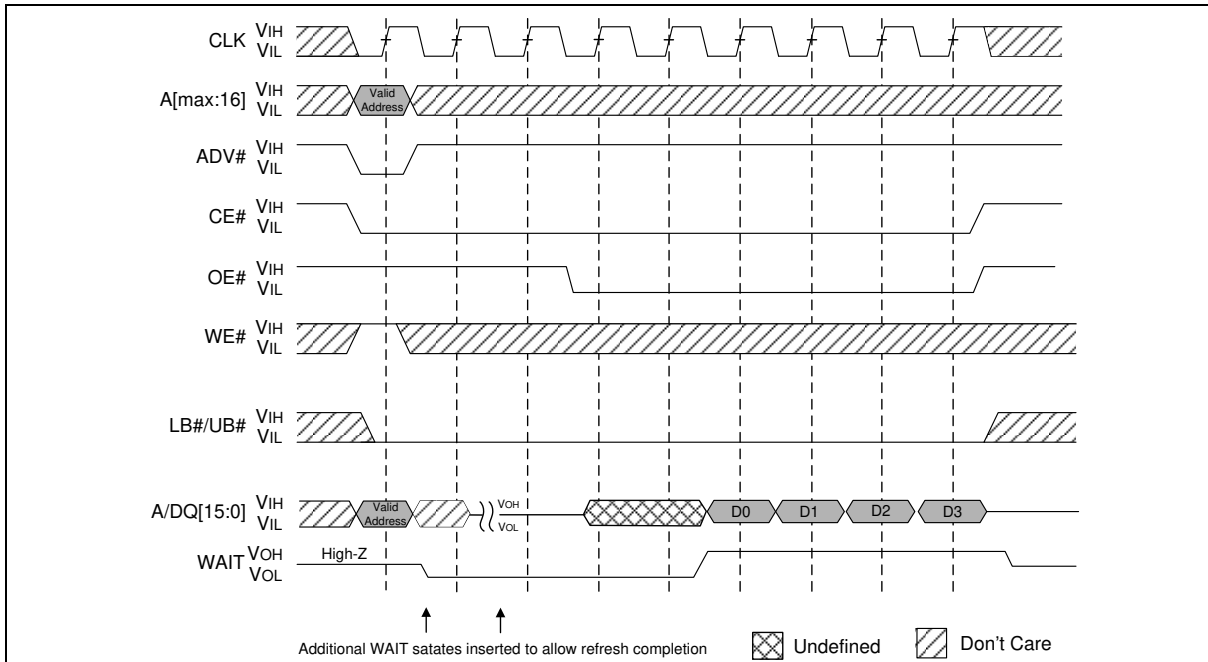

Note:

Non-default BCR settings for refresh collision during variable-latency READ operation: latency code 2 (3 clocks), WAIT active LOW, WAIT asserted during delay.



8.2.3 Mixed-Mode Operation

The device supports a combination of synchronous WRITE / READ and asynchronous WRITE / READ operations when the BCR is configured for synchronous operation. The asynchronous WRITE operations require that the clock (CLK) remain static (HIGH or LOW) during the entire sequence. The ADV# signal can be used to latch the target address, or it can remain LOW during the entire WRITE operation. CE# can remain LOW when transitioning between mixed-mode operations with fixed latency enabled; however, the CE# LOW time must not exceed tCEM. Mixed-mode operation facilitates a seamless interface to legacy burst mode Flash memory controllers.

8.2.4 WAIT Operation

The WAIT output on a ADMUX PSRAM device is typically connected to a shared, system level WAIT signal. The shared WAIT signal is used by the processor to coordinate transactions with multiple memories on the synchronous bus.

8.2.4.1 Wired-OR WAIT Configuration

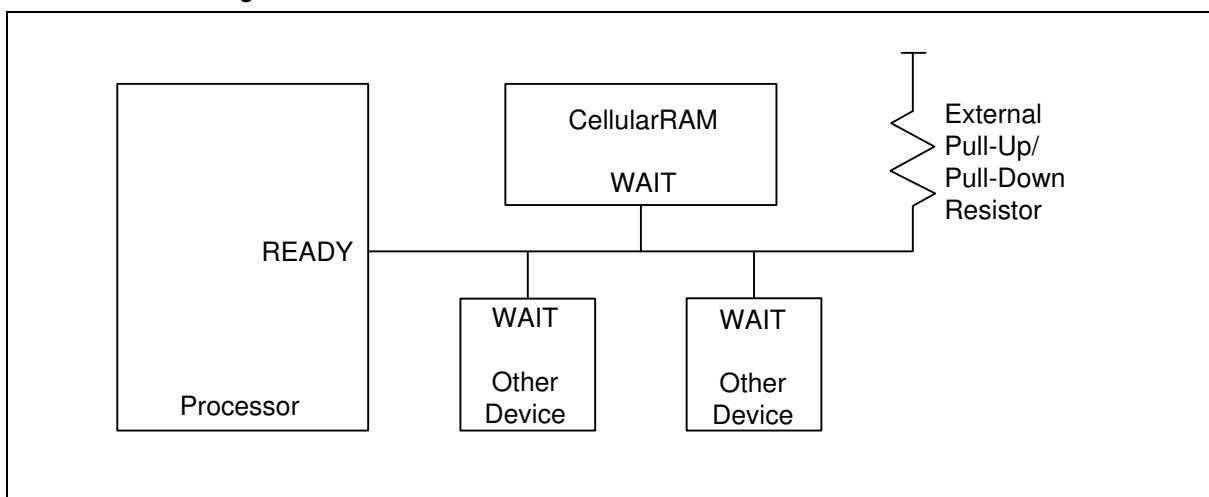

When a READ or WRITE operation has been initiated, WAIT goes active to indicate that the ADMUX PSRAM device requires additional time before data can be transferred. For READ operations, WAIT will remain active until valid data is output from the device. For WRITE operations, WAIT will indicate to the memory controller when data will be accepted into the ADMUX PSRAM device. When WAIT transitions to an inactive state, the data burst will progress on successive clock edges.

During a burst cycle, CE# must remain asserted until the first data is valid. Bringing CE# HIGH during this initial latency may cause data corruption.

When using variable initial access latency (BCR[14] = 0), the WAIT output performs an arbitration role for burst READ operations launched while an on-chip refresh is in progress. If a collision occurs, WAIT is asserted for additional clock cycles until the refresh has completed. When the refresh operation has completed, the burst READ operation will continue normally.

WAIT is also asserted when a continuous READ or WRITE burst crosses a row boundary. The WAIT assertion allows time for the new row to be accessed.

WAIT will be asserted after OE# goes LOW during asynchronous READ operations. WAIT will be High-Z during asynchronous WRITE operations. WAIT should be ignored during all asynchronous operations.

By using fixed initial latency (BCR[14] = 1), this ADMUX PSRAM device can be used in burst mode without monitoring the WAIT signal. However, WAIT can still be used to determine when valid data is available at the start of the burst and at the end of the row. If WAIT is not monitored, the controller must stop burst accesses at row boundaries on its own.



8.2.5 LB# / UB# Operation

The LB# enable and UB# enable signals support byte-wide data WRITES. During WRITE operations, any disabled bytes will not be transferred to the RAM array and the internal value will remain unchanged. During an asynchronous WRITE cycle, the data to be written is latched on the rising edge of CE#, WE#, LB#, or UB#, whichever occurs first. LB# and UB# must be LOW during READ cycles.

When both the LB# and UB# are disabled (HIGH) during an operation, the device will disable the data bus from receiving or transmitting data. Although the device will seem to be deselected, it remains in an active mode as long as CE# remains LOW.

8.3 Low Power Operation

8.3.1 Standby Mode Operation

During standby, the device current consumption is reduced to the level necessary to perform the DRAM refresh operation. Standby operation occurs when CE# is HIGH. The device will enter a reduced power state upon completion of a READ or WRITE operation, or when the address and control inputs remain static for an extended period of time. This mode will continue until a change occurs to the address or control inputs.

8.3.2 Temperature Compensated Refresh

Temperature-compensated refresh (TCR) allows for adequate refresh at different temperatures. This ADMUX PSRAM device includes an on-chip temperature sensor that automatically adjusts the refresh rate according to the operating temperature. The device continually monitors the temperature to select an appropriate self-refresh rate.

8.3.3 Partial-Array Refresh

Partial-array refresh (PAR) restricts refresh operation to a portion of the total memory array. This feature enables the device to reduce standby current by refreshing only that part of the memory array required by the host system. The refresh options are full array, one-half array, one-quarter array, one-eighth array, or none of the array. The mapping of these partitions can start at either the beginning or the end of the address map. READ and WRITE operations to address ranges receiving refresh will not be affected. Data stored in addresses not receiving refresh will become corrupted. When additional portions of the array need to be re-enabled, the new portions are available immediately after the completion of the WRITE cycle that updates the RCR with the new configuration.

8.3.4 Deep Power-Down Operation

Deep power-down (DPD) operation disables all refresh-related activity. This mode is used if the system does not require the storage provided by the AD MUX PSRAM device. Any stored data will become corrupted when DPD is enabled. When refresh activity has been re-enabled, the AD MUX PSRAM device will require 150 μ s to perform an initialization procedure before normal operations can resume. During this 150 μ s period, the current consumption will be higher than the specified standby levels, but considerably lower than the active current specification.

DPD can be enabled by writing to the RCR using CRE or the software access sequence; DPD starts when CE# goes HIGH. DPD is disabled the next time CE# goes LOW and stays LOW for at least 10 μ s.



8.4.1.2 Configuration Register WRITE Synchronous Mode Followed by READ Operation

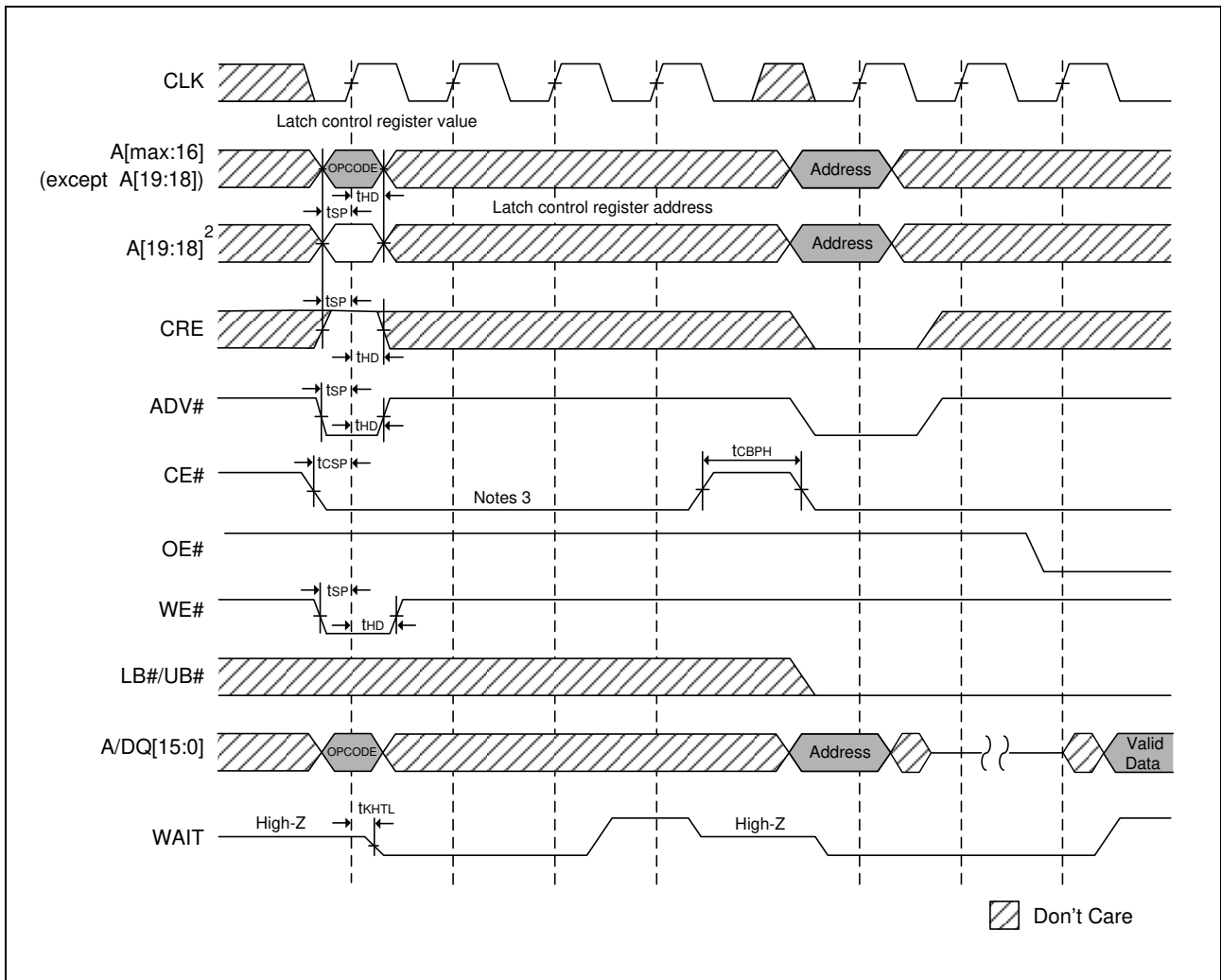

Notes:

1. Non-default BCR settings for synchronous mode configuration register WRITE followed by READ ARRAY operation: latency code 2 (3 clocks), WAIT active LOW, WAIT asserted during delay.
2. A[19:18] = 00b to load RCR, and 10b to load BCR.
3. CE# must remain LOW to complete a burst-of-one WRITE. WAIT must be monitored—additional WAIT cycles caused by refresh collisions require a corresponding number of additional CE# LOW cycles.



8.4.1.3 Configuration Register READ Asynchronous Mode Followed by READ ARRAY Operation

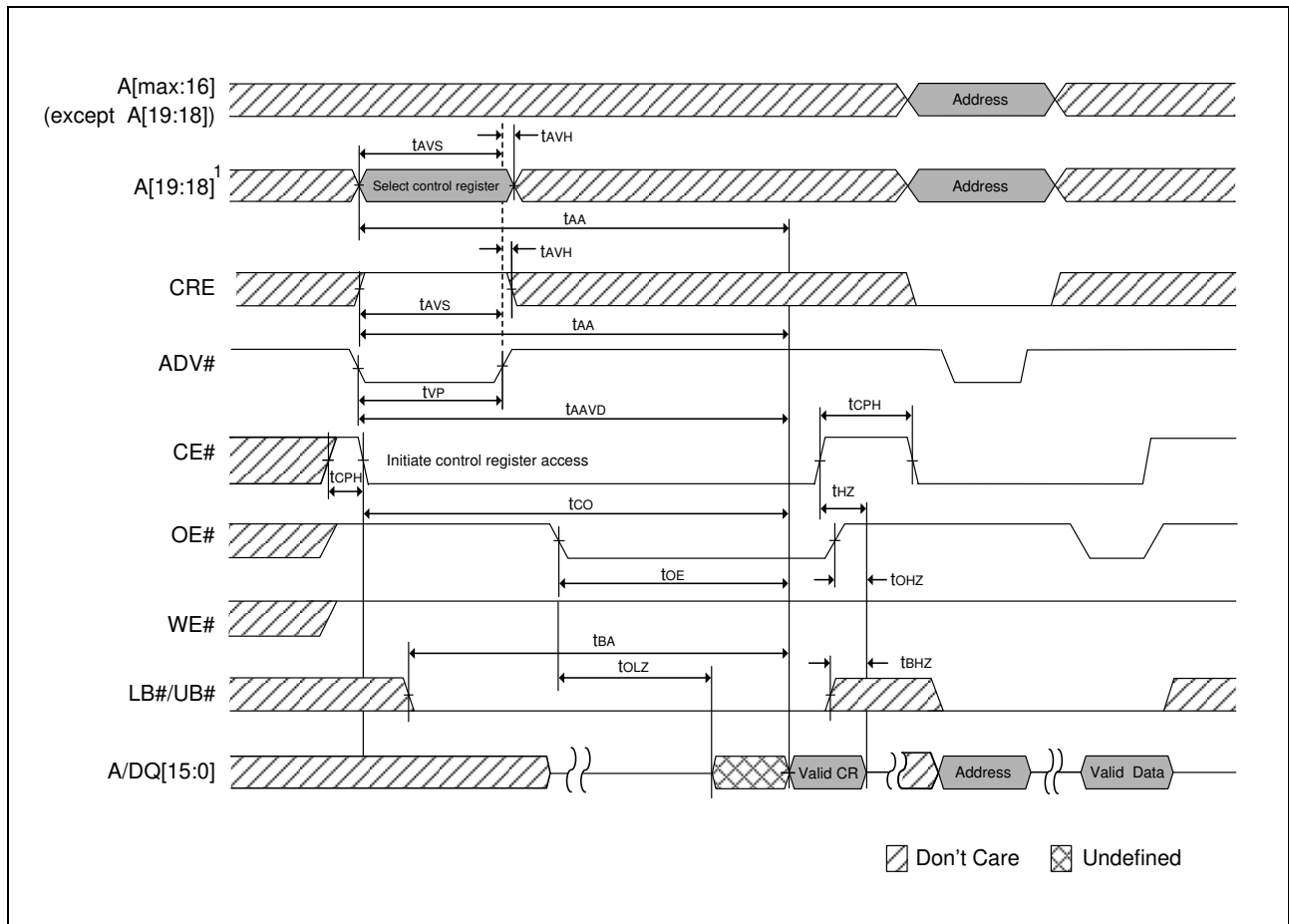

Note:

A[19:18] = 00b to read RCR, 10b to read BCR, and 01b to read DIDR.



8.4.1.4 Configuration Register READ Synchronous Mode Followed by READ ARRAY Operation

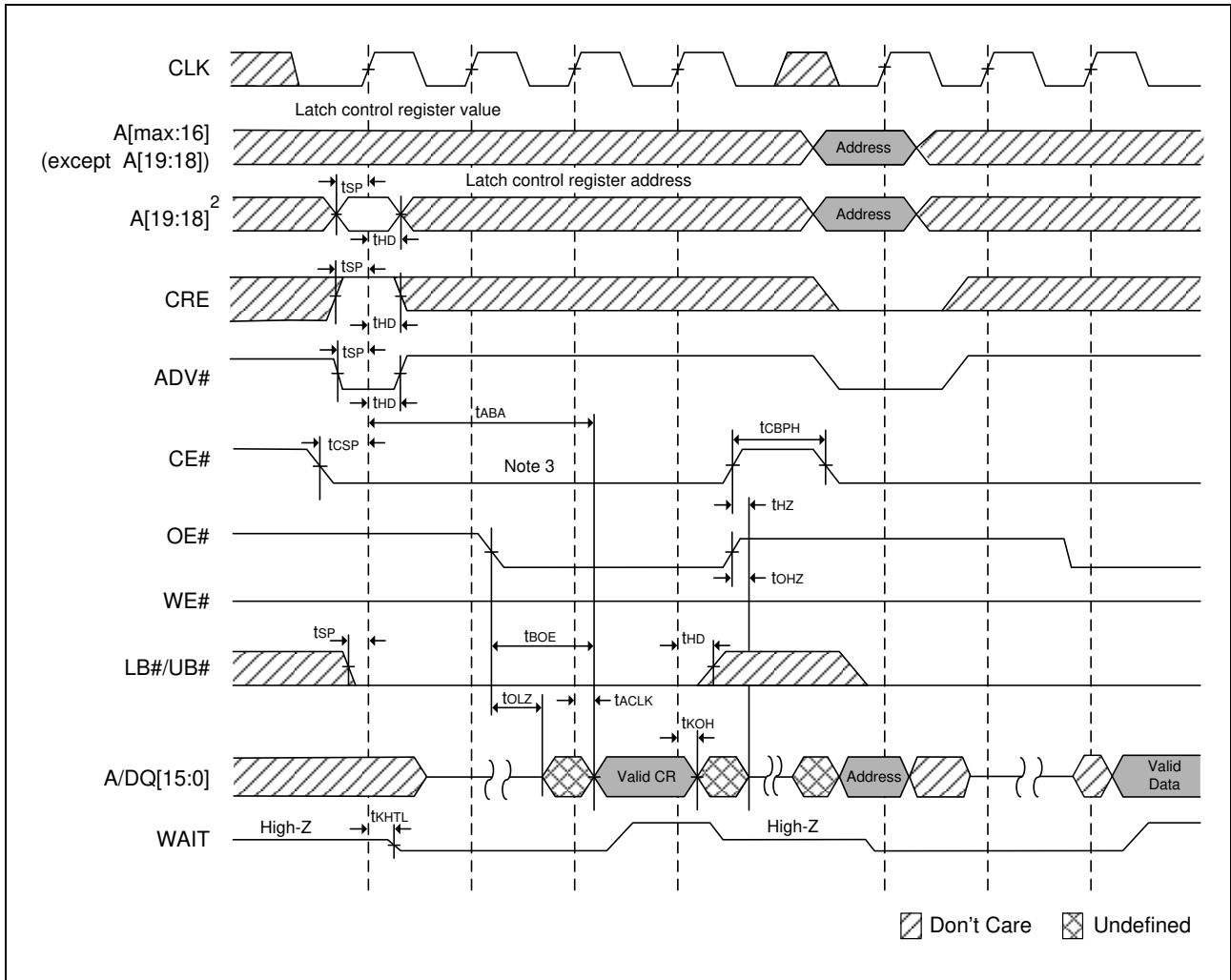

Notes:

1. Non-default BCR settings for synchronous mode register READ followed by READ ARRAY operation: Latency code 2 (3 clocks): WAIT active LOW; WAIT asserted during delay.
2. A[19:18]=00b to read RCR, 10b to read BCR, and 01b to read DIDR.
3. CE# must remain LOW to complete a burst-of-one READ. WAIT must be monitored—additional WAIT cycles caused by refresh collisions require a corresponding number of additional CE# LOW cycles.



8.4.2 Software Access

Software access of the registers uses a sequence of asynchronous READ and asynchronous WRITE operations. The contents of the configuration registers can be modified and all registers can be read using the software sequence. The configuration registers are loaded using a four-step sequence consisting of two asynchronous READ operations followed by two asynchronous WRITE operations.

The read sequence is virtually identical except that an asynchronous READ is performed during the fourth operation. The address used during all READ and WRITE operations is the highest address of the ADMUX PSRAM device being accessed; the contents of this address are not changed by using this sequence.

The data value presented during the third operation (WRITE) in the sequence defines whether the BCR, RCR, is to be accessed. If the data is 0000h, the sequence will access the RCR; if the data is 0001h, the sequence will access the BCR. During the fourth operation, ADQ[15:0] transfer data in to or out of bits 15:0 of the registers.

The use of the software sequence does not affect the ability to perform the standard (CRE-controlled) method of loading the configuration registers. However, the software nature of this access mechanism eliminates the need for CRE. If the software mechanism is used, CRE can simply be tied to Vss. The port line often used for CRE control purposes is no longer required.

8.4.2.1 Load Configuration Register

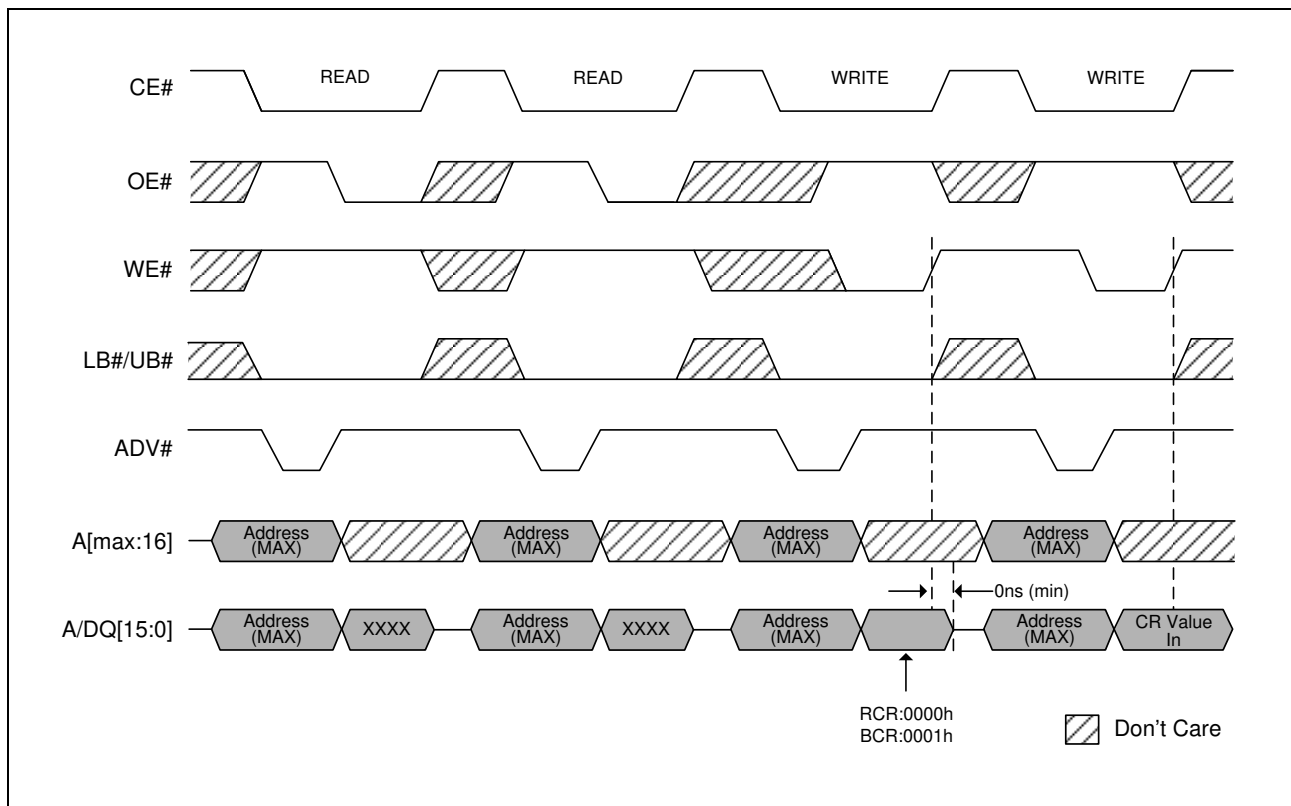



8.4.2.2 Read Configuration Register

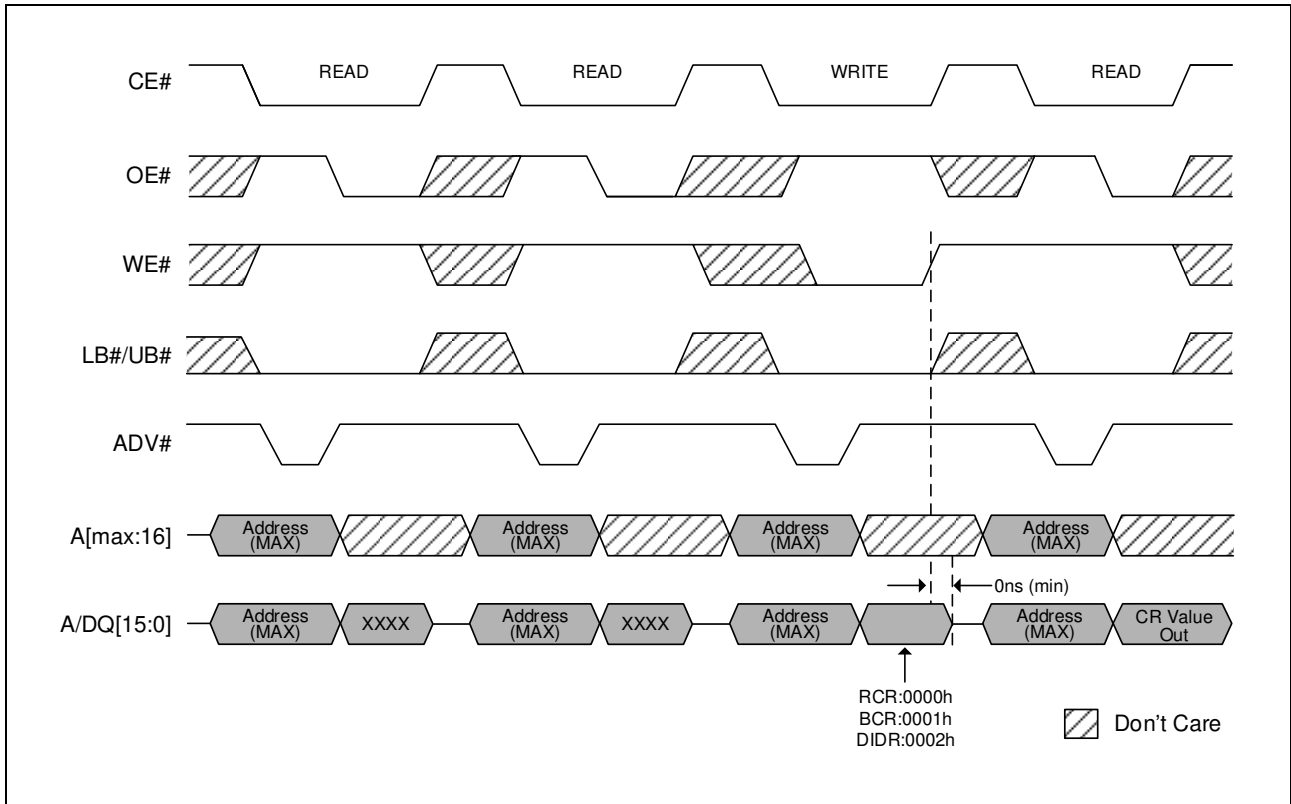

8.4.3 Bus Configuration Register

The BCR defines how the ADMUX PSRAM device interacts with the system memory bus. At power-up, the BCR is set to 9D1Fh. The BCR is accessed with CRE HIGH and A[19:18] = 10b, or through the register access software sequence with A/DQ = 0001h on the third cycle.



8.4.3.1 Bus Configuration Register Definition

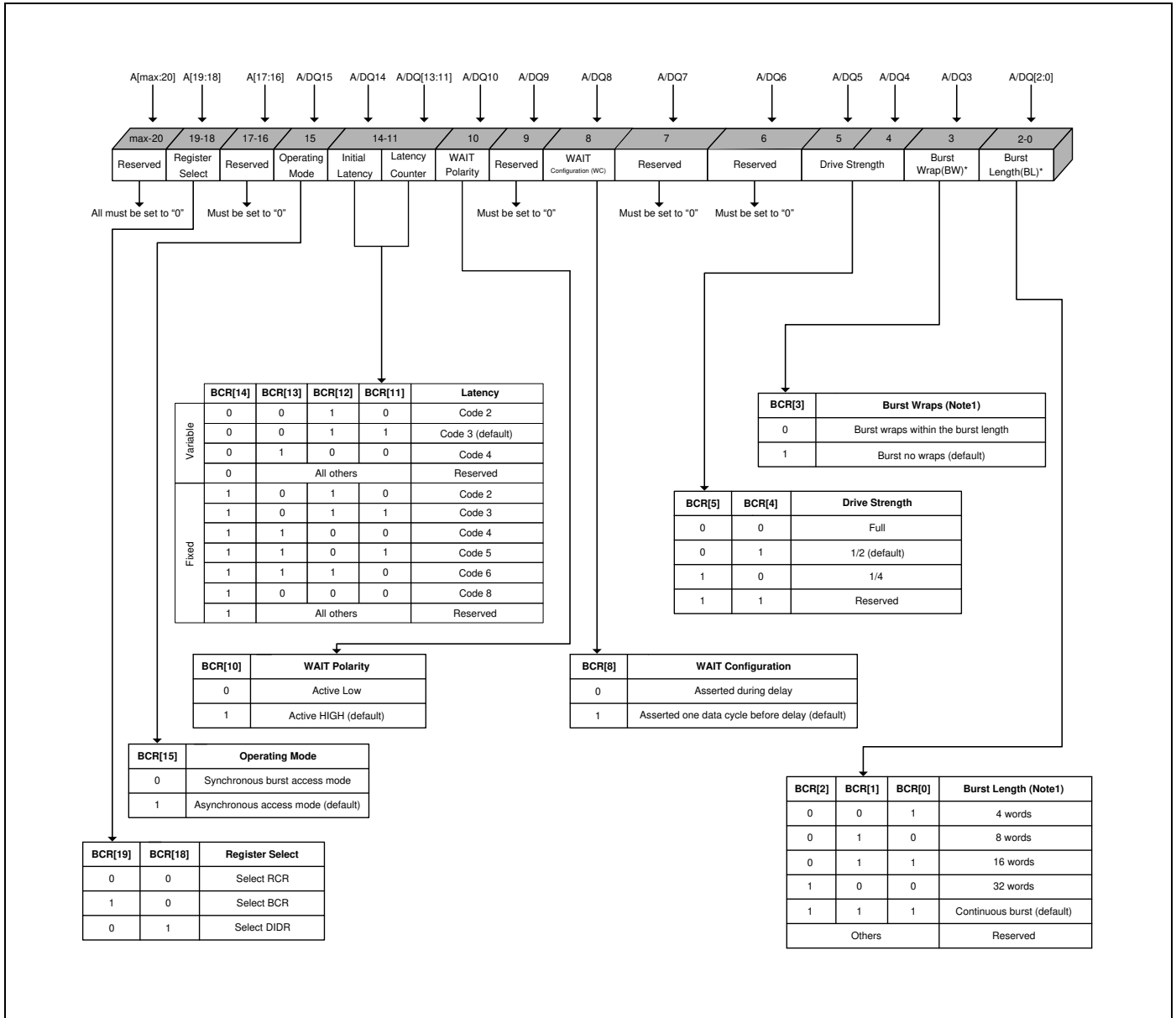

Notes:

1. Burst wrap and length apply to both READ and WRITE operations.
2. Reserved bits must be set to zero. Reserved bits not set to zero will affect device functionality. BCR[15:0] will be read back as written.



8.4.3.2 Burst Length (BCR[2:0]) Default = Continuous Burst

Burst lengths define the number of words the device outputs during burst READ and WRITE operations. The device supports a burst length of 4, 8, 16, or 32 words.

The device can also be set in continuous burst mode where data is output sequentially without regard to address boundaries; the internal address wraps to 000000h if the device is read past the last address.

8.4.3.3 Burst Wrap (BCR[3]) Default = No Wrap

The burst-wrap option determines if a 4-, 8-, 16-, or 32-word READ or WRITE burst wraps within the burst length, or steps through sequential addresses.

If the wrap option is not enabled, the device accesses data from sequential addresses without regard to address boundaries; the internal address wraps to 000000h if the device is read past the last address.



8.4.3.4 Sequence and Burst Length

Burst Wrap		Start Addr	4-Word Burst Length	8-Word Burst Length	16-Word Burst Length	32-Word Burst Length	Continuous Burst
BCR[3]	Wrap	Decimal	Linear	Linear	Linear	Linear	Linear
0	Yes	0	0-1-2-3	0-1-2-3-4-5-6-7	0-1-2-3-4-5-6-7-8-9-10-11-12-13-14-15	0-1-2-...-29-30-31	0-1-2-3-4-5-6-...
		1	1-2-3-0	1-2-3-4-5-6-7-0	1-2-3-4-5-6-7-8-9-10-11-12-13-14-15-0	1-2-3-...-30-31-0	1-2-3-4-5-6-7-...
		2	2-3-0-1	2-3-4-5-6-7-0-1	2-3-4-5-6-7-8-9-10-11-12-13-14-15-0-1	2-3-4-...-31-0-1	2-3-4-5-6-7-8-...
		3	3-0-1-2	3-4-5-6-7-0-1-2	3-4-5-6-7-8-9-10-11-12-13-14-15-0-1-2	3-4-5-...-0-1-2	3-4-5-6-7-8-9-...
		4		4-5-6-7-0-1-2-3	4-5-6-7-8-9-10-11-12-13-14-15-0-1-2-3	4-5-6-...-1-2-3	4-5-6-7-8-9-10-...
		5		5-6-7-0-1-2-3-4	5-6-7-8-9-10-11-12-13-14-15-0-1-2-3-4	5-6-7-...-2-3-4	5-6-7-8-9-10-11-...
		6		6-7-0-1-2-3-4-5	6-7-8-9-10-11-12-13-14-15-0-1-2-3-4-5	6-7-8-...-3-4-5	6-7-8-9-10-11-12-
		7		7-0-1-2-3-4-5-6	7-8-9-10-11-12-13-14-15-0-1-2-3-4-5-6	7-8-9-...-4-5-6	7-8-9-10-11-12-13-...
	
		14			14-15-0-1-2-3-4-5-6-7-8-9-10-11-12-13	14-15-16-...-11-12-13	14-15-16-17-18-19-20-...
		15			15-0-1-2-3-4-5-6-7-8-9-10-11-12-13-14	15-16-17-...-12-13-14	15-16-17-18-19-20-21-...
	
		30				30-31-0-...-27-28-29	30-31-32-33-34-...
		31				31-0-1-...-28-29-30	31-32-33-34-35-...
1	No	0	0-1-2-3	0-1-2-3-4-5-6-7	0-1-2-3-4-5-6-7-8-9-10-11-12-13-14-15	0-1-2-...-29-30-31	0-1-2-3-4-5-6-...
		1	1-2-3-4	1-2-3-4-5-6-7-8	1-2-3-4-5-6-7-8-9-10-11-12-13-14-15-16	1-2-3-...-30-31-32	1-2-3-4-5-6-7-...
		2	2-3-4-5	2-3-4-5-6-7-8-9	2-3-4-5-6-7-8-9-10-11-12-13-14-15-16-17	2-3-4-...-31-32-33	2-3-4-5-6-7-8-...
		3	3-4-5-6	3-4-5-6-7-8-9-10	3-4-5-6-7-8-9-10-11-12-13-14-15-16-17-18	3-4-5-...-32-33-34	3-4-5-6-7-8-9-...
		4		4-5-6-7-8-9-10-11	4-5-6-7-8-9-10-11-12-13-14-15-16-17-18-19	4-5-6-...-33-34-35	4-5-6-7-8-9-10-...
		5		5-6-7-8-9-10-11-12	5-6-7-8-9-10-11-12-13-...-15-16-17-18-19-20	5-6-7-...-34-35-36	5-6-7-8-9-10-11-...
		6		6-7-8-9-10-11-12-13	6-7-8-9-10-11-12-13-14-...-16-17-18-19-20-21	6-7-8-...-35-36-37	6-7-8-9-10-11-12-...
		7		7-8-9-10-11-12-13-14	7-8-9-10-11-12-13-14-...-17-18-19-20-21-22	7-8-9-...-36-37-38	7-8-9-10-11-12-13-...
	
		14			14-15-16-17-18-19-...-23-24-25-26-27-28-29	14-15-16-...-43-44-45	14-15-16-17-18-19-20-...
		15			15-16-17-18-19-20-...-24-25-26-27-28-29-30	15-16-17-...-44-45-46	15-16-17-18-19-20-21-...
	
		30				30-31-32-...-59-60-61	30-31-32-33-34-35-36-...
		31				31-32-33-...-60-61-62	31-32-33-34-35-36-37-...



8.4.3.5 Drive Strength (BCR[5:4]) Default = Outputs Use Half-Drive Strength

The output driver strength can be altered to full, one-half, or one-quarter strength to adjust for different data bus loading scenarios. The reduced-strength options are intended for stacked chip (Flash + ADMUX PSRAM) environments when there is a dedicated memory bus. The reduced-drive-strength option minimizes the noise generated on the data bus during READ operations. Full output drive strength should be selected when using a discrete ADMUX PSRAM device in a more heavily loaded data bus environment. Outputs are configured at half-drive strength during testing.

8.4.3.6 Table of Drive Strength

BCR[5]	BCR[4]	Drive Strength	Impedance Typ (Ω)	Use Recommendation
0	0	Full	25–30	CL = 30pF to 50pF
0	1	1/2 (default)	50	CL = 15pF to 30pF
1	0	1/4	100	CL = 15pF or lower
1	1	Reserved		

8.4.3.7 WAIT Configuration. (BCR[8])

Default = WAIT Transitions 1 Clock Before Data Valid/ Invalid

The WAIT configuration bit is used to determine when WAIT transitions between the asserted and the de-asserted state with respect to valid data presented on the data bus. The memory controller will use the WAIT signal to coordinate data transfer during synchronous READ and WRITE operations. When BCR[8] = 0, data will be valid or invalid on the clock edge immediately after WAIT transitions to the de-asserted or asserted state, respectively. When BCR[8] = 1, the WAIT signal transitions one clock period prior to the data bus going valid or invalid.

8.4.3.8 WAIT Polarity (BCR[10])

Default = WAIT Active HIGH

The WAIT polarity bit indicates whether an asserted WAIT output should be HIGH or LOW. This bit will determine whether the WAIT signal requires a pull-up or pull-down resistor to maintain the de-asserted state.

The default value is BCR[10]=1, indicating WAIT active HIGH.



8.4.3.9 WAIT Configuration During Burst Operation

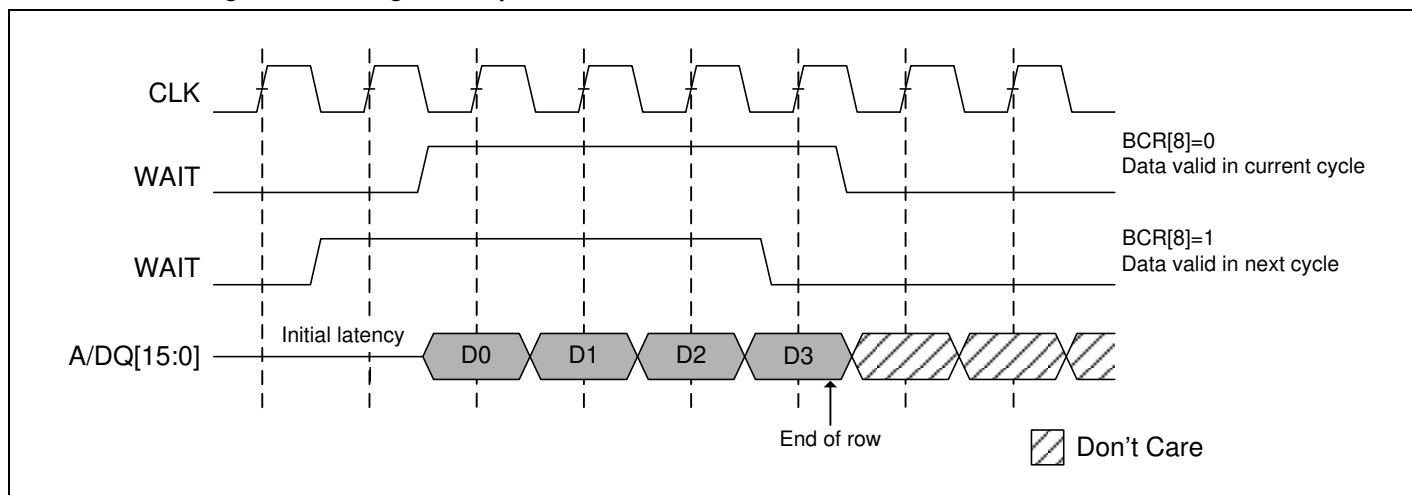

Note:

Signals shown are for WAIT active LOW, no wrap.

8.4.3.10 Latency Counter (BCR[13:11]) Default = Three Clock Latency

The latency counter bits determine how many clocks occur between the beginning of a READ or WRITE operation and the first data value transferred. For allowable latency codes, see the following tables and figures.

8.4.3.11 Initial Access Latency (BCR[14]) Default = Variable

Variable initial access latency outputs data after the number of clocks set by the latency counter. However, WAIT must be monitored to detect delays caused by collisions with refresh operations.

Fixed initial access latency outputs the first data at a consistent time that allows for worst-case refresh collisions. The latency counter must be configured to match the initial latency and the clock frequency. It is not necessary to monitor WAIT with fixed initial latency. The burst begins after the number of clock cycles configured by the latency counter.

8.4.3.12 Allowed Latency Counter Settings in Variable Latency Mode

BCR[13:11]	Latency Configuration Code	Latency ¹		Max Input CLK Frequency (MHz)	
		Normal	Maximum with Refresh Collision	133	104
010	2 (3 clocks)	2	4	66 (15ns)	66 (15ns)
011	3(4clocks)—default	3	6	104 (9.62ns)	104 (9.62ns)
100	4 (5 clocks)	4	8	133 (7.5ns)	—
Others	Reserved	—	—	—	—

Note:

1. Latency is the number of clock cycles from the initiation of a burst operation until data appears. Data is transferred on the next clock cycle.



8.4.3.13 Latency Counter (Variable Initial Latency, No Refresh Collision)

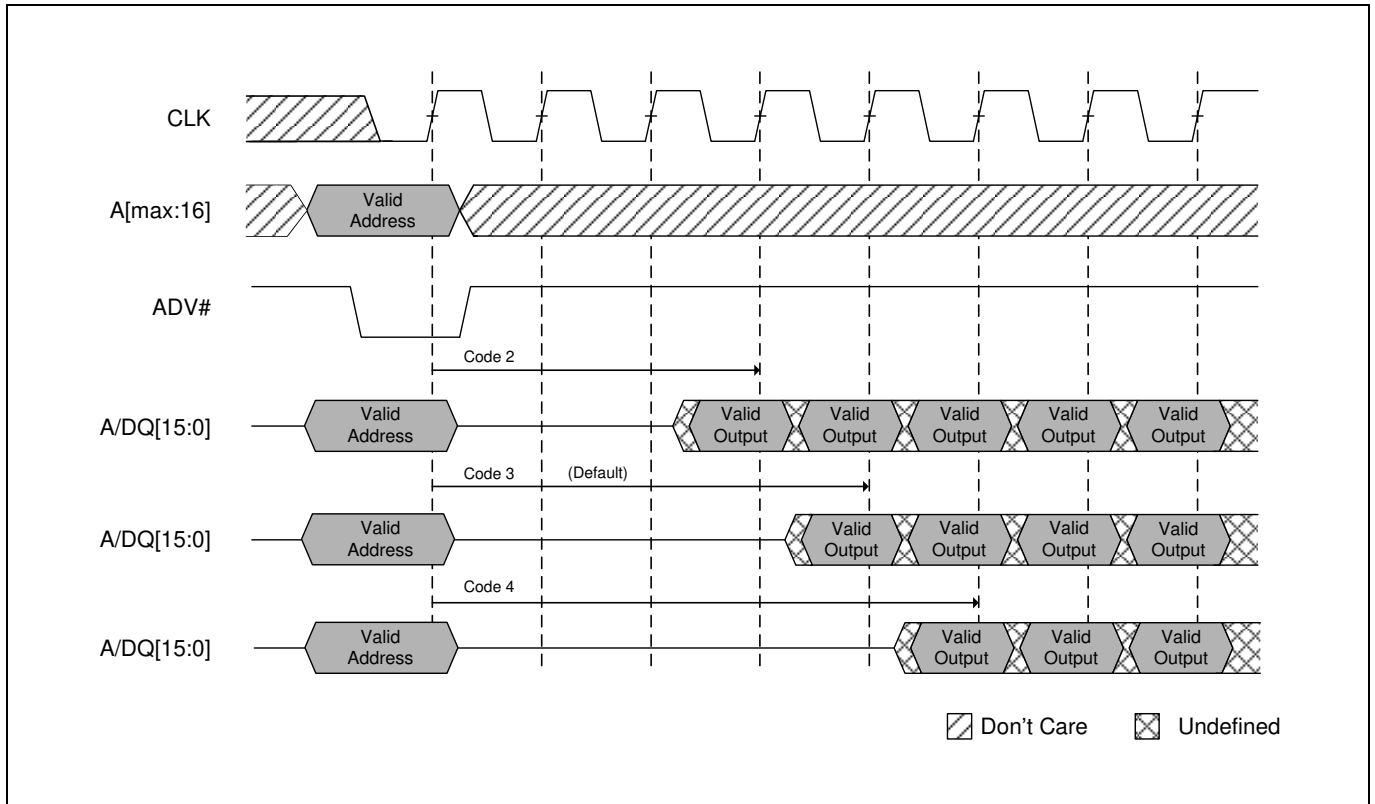

8.4.3.14 Allowed Latency Counter Settings in Fixed Latency Mode

BCR[13:11]	Latency Configuration Code	Latency Count (N)	Max Input CLK Frequency (MHz)	
			133	104
010	2 (3 clocks)	2	33 (30ns)	33 (30ns)
011	3 (4 clocks)—default	3	52 (19.2ns)	52 (19.2ns)
100	4 (5 clocks)	4	66 (15ns)	66 (15ns)
101	5 (6 clocks)	5	75 (13.3ns)	75 (13.3ns)
110	6 (7 clocks)	6	104 (9.62ns)	104 (9.62ns)
000	8 (9 clocks)	8	133 (7.5ns)	—
Others	Reserved	—	—	—



8.4.3.15 Latency Counter (Fixed Latency)

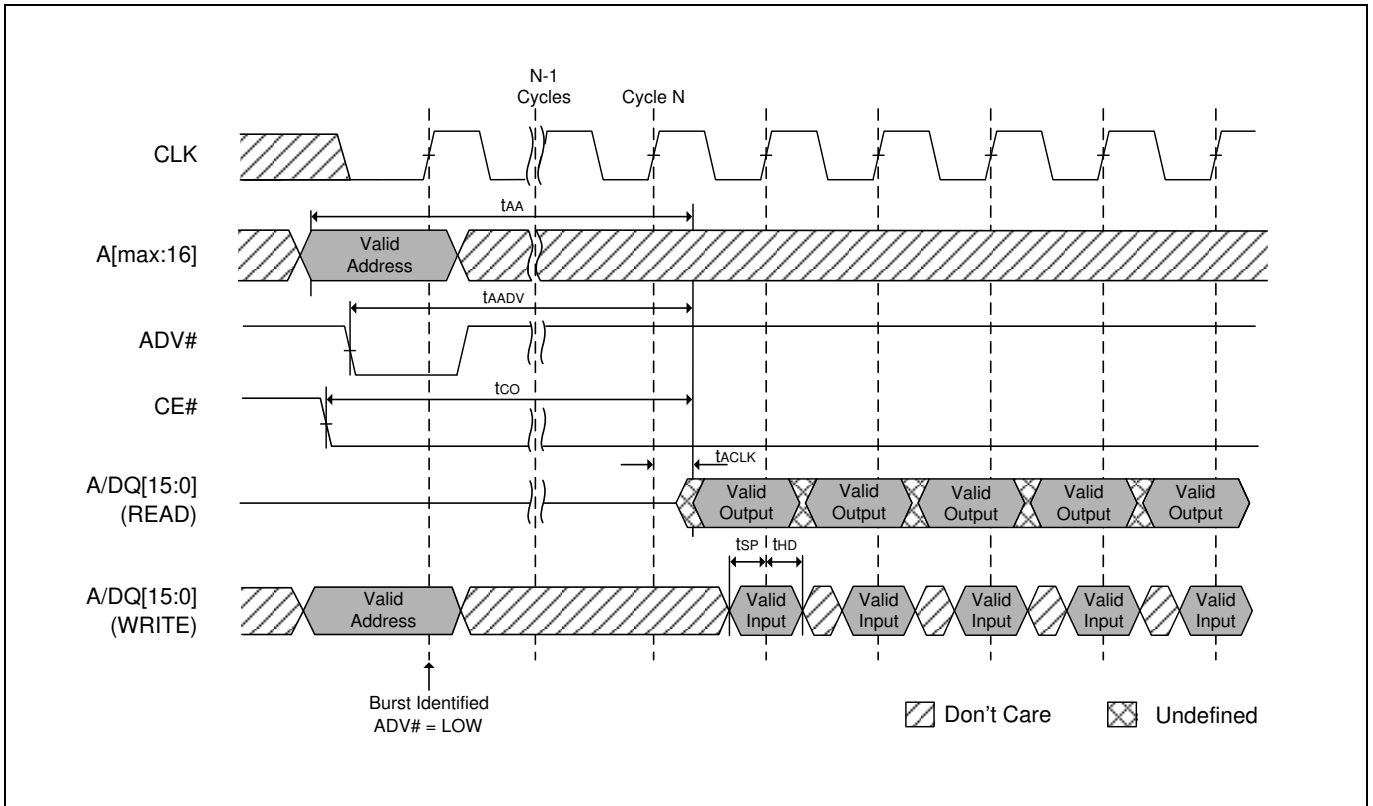

8.4.3.16 Operating Mode (BCR[15])

Default = Asynchronous Operation

The operating mode bit selects either synchronous burst operation or the default asynchronous mode of operation.



8.4.4 Refresh Configuration Register

The refresh configuration register (RCR) defines how the ADMUX PSRAM device performs its transparent self refresh. Altering the refresh parameters can dramatically reduce current consumption during standby mode. At power-up, the RCR is set to 0010h. The RCR is accessed with CRE HIGH and A[19:18] = 00b; or through the register access software sequence with A/DQ = 0000h on the third cycle.

8.4.4.1 Refresh Configuration Register Mapping

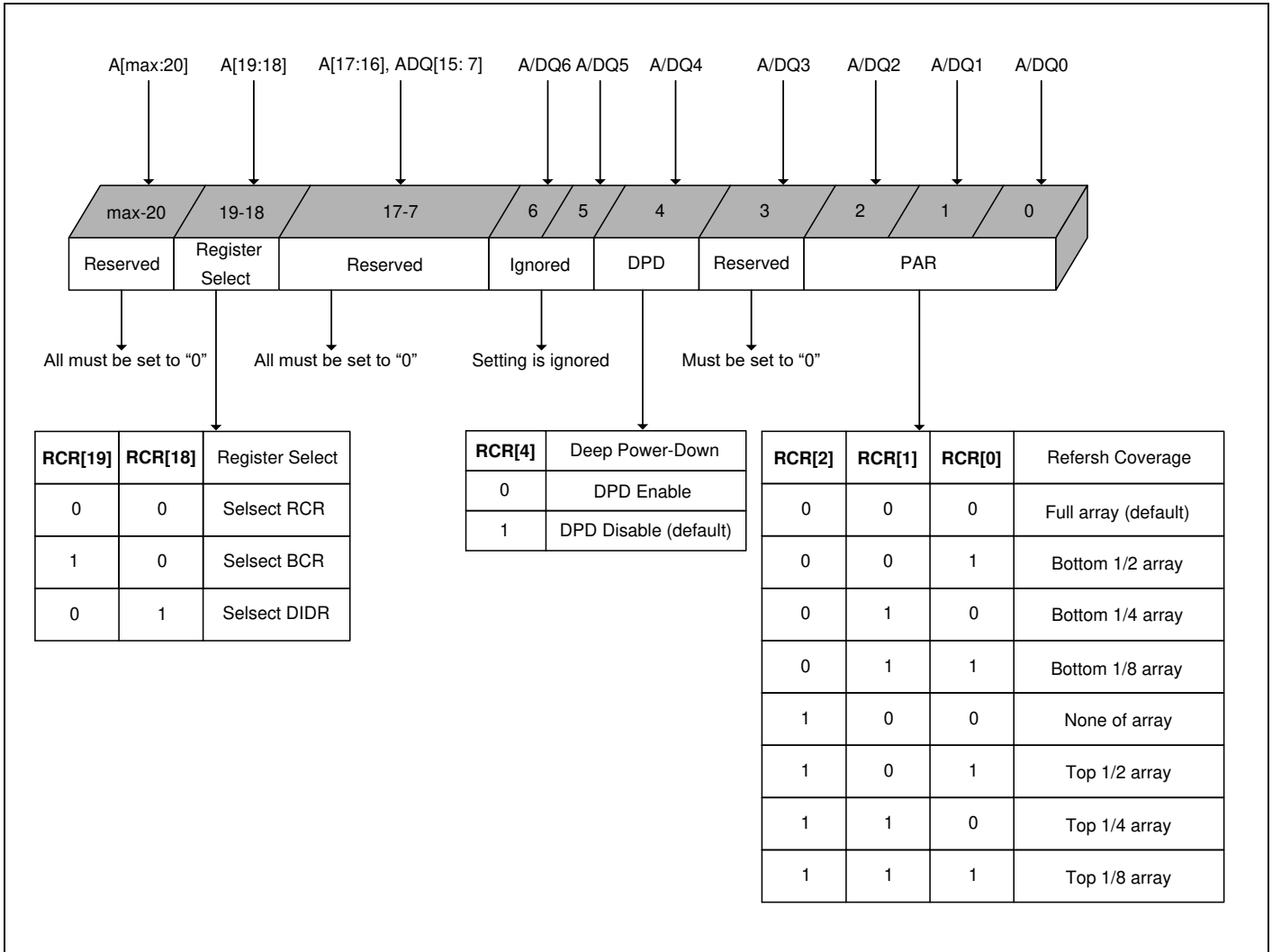

Note:

Reserved bits must be set to zero. Reserved bits not set to zero will affect device functionality. RCR[15:0] will be read back as written.

8.4.4.2 Partial Array Refresh (RCR[2:0]) Default = Full Array Refresh

The PAR bits restrict refresh operation to a portion of the total memory array. This feature allows the device to reduce standby current by refreshing only that part of the memory array required by the host system. The refresh options are full array, one-half array, one-quarter array, one-eighth array, or none of the array. The mapping of these partitions can start at either the beginning or the end of the address map.



8.4.4.3 Address Patterns for PAR (RCR [4] = 1)

RCR[2]	RCR[1]	RCR[0]	Active Section	Address Space	Size	Density
0	0	0	Full die	000000h–FFFFFFh	16 Meg x 16	256Mb
0	0	1	One-half of die	000000h–7FFFFFFh	8 Meg x 16	128Mb
0	1	0	One-quarter of die	000000h–3FFFFFFh	4 Meg x 16	64Mb
0	1	1	One-eighth of die	000000h–1FFFFFFh	2 Meg x 16	32Mb
1	0	0	None of die	0	0 Meg x 16	0Mb
1	0	1	One-half of die	800000h–FFFFFFh	8 Meg x 16	128Mb
1	1	0	One-quarter of die	C00000h–FFFFFFh	4 Meg x 16	64Mb
1	1	1	One-eighth of die	E00000h–FFFFFFh	2 Meg x 16	32Mb

8.4.4.4 Deep Power-Down (RCR[4]) Default = DPD Disabled

The deep power-down bit enables and disables all refresh-related activity. This mode is used if the system does not require the storage provided by the ADMUX PSRAM device. Any stored data will become corrupted when DPD is enabled. When refresh activity has been re-enabled, the ADMUX PSRAM device will require 150µs to perform an initialization procedure before normal operations can resume.

Deep power-down is enabled by setting RCR[4] = 0 and taking CE# HIGH. DPD can be enabled using CRE or the software sequence to access the RCR. Taking CE# LOW for at least 10µs disables DPD and sets RCR[4] = 1; it is not necessary to write to the RCR to disable DPD. BCR and RCR values (other than RCR[4]) are preserved during DPD.

8.4.5 Device Identification Register

The DIDR provides information on the device manufacturer, CellularRAM generation, and the specific device configuration. This register is read-only.

The DIDR is accessed with CRE HIGH and A[19:18] = 01b, or through the register access software sequence with ADQ = 0002h on the third cycle.

8.4.5.1 Device Identification Register Mapping

Bit Field	DIDR[15]		DIDR[14:11]		DIDR[10:8]		DIDR[7:5]		DIDR[4:0]	
Field name	Row length		Device version		Device density		CellularRAM generation		Vendor ID	
Options	Length	Bit Setting	Version	Bit Setting	Density	Bit Setting	Generation	Bit Setting	Vendor	Bit Setting
	256 words	1b	1st	0000b	256Mb	100b	CR1.5	010b	Winbond	00110b
			2nd	0001b						

8.4.5.2 Virtual Chip Enable Function:

A 512Mb device can be implemented by a MCP consisting of two stacked 256Mb devices with Virtual Chip Enable function. By proper configuration, one 256Mb device of the MCP is mapped to the lower 256Mb memory space of the 512Mb device and the another one 256Mb device is mapped to the upper 256Mb memory space of the 512Mb device. The 256Mb device with Virtual Chip Enable function provides a VCE input pin which is controlled by the A24 (the MSB of address bus of 512Mb memory space). When the 256Mb device is mapped to the lower 256Mb memory space, the device will be active if A24 is low. When the 256Mb device is mapped to the upper 256Mb memory space, the device will be active if A24 is high.



9. ELECTRICAL CHARACTERISTIC

9.1 Absolute Maximum DC, AC Ratings

Parameter	Min	Max	Unit
Operating temperature (case) Wireless	-40	+85	°C
Storage temperature (plastic)	-55	+150	°C
Soldering temperature and time 10s (solder ball only)	+260		°C
Voltage to any ball except VCC, VCCQ relative to VSS	-0.3	VCCQ +0.3	V
Voltage on VCC supply relative to VSS	-0.20	+2.45	V
Voltage on VCCQ supply relative to VSS	-0.20	+2.45	V

Stresses greater than those listed may cause permanent damage to the device. This is a stress rating only, and functional operation of the device at these or any other conditions above those indicated in the operational sections of this specification is not implied. Exposure to absolute maximum rating conditions for extended periods may affect reliability.

9.2 Electrical Characteristics and Operating Conditions

Description	Conditions	Symbol	Typical	Min	Max	Unit	Note
Supply voltage		VCC		1.7	1.95	V	
I/O supply voltage		VCCQ		1.7	1.95	V	
Input high voltage		VIH		VCCQ-0.4	VCCQ+0.2	V	1
Input low voltage		VIL		-0.20	0.4	V	2
Output high voltage	IOH=-0.2mA	VOH		0.8xVCCQ		V	3
Output low voltage	IOL=+0.2mA	VOL			0.2xVCCQ	V	3
Input leakage current	VIN=0 to VCCQ	ILI			1	μA	
Output leakage current	OE#=VIH or chip disabled	ILO			1	μA	
Operating Current							
Asynchronous random READ/WRITE	VIN = VCCQ or 0V, Chip enabled, IOUT=0	ICC1	tRC/tWC=70ns	-	25	mA	4
Initial access, burst READ/WRITE		ICC2	133MHz	-	40	mA	4
			104MHz	-	35		
Continuous burst READ		ICC3R	133MHz	-	35	mA	4
			104MHz	-	30		
Continuous burst WRITE		ICC3W	133MHz	-	40	mA	4
	104MHz		-	35			
Standby Current	VIN = VCCQ or 0V, CE# = VCCQ	ISB	Standard	-	400	μA	5, 6

Notes:

- Input signals may overshoot to VCCQ + 1.0V for periods less than 2ns during transitions.
- Input signals may undershoot to VSS - 1.0V for periods less than 2ns during transitions.
- BCR[5:4] = 01b (default setting of one-half drive strength).
- This parameter is specified with the outputs disabled to avoid external loading effects. The user must add the current required to drive output capacitance expected in the actual system.
- ISB (max) values measured with PAR set to FULL ARRAY and at +85°C. In order to achieve low standby current, all inputs must be driven to either VCCQ or VSS. ISB might be slightly higher for up to 500ms after power-up, or when entering standby mode.



9.3 Deep Power-Down Specifications

Description	Conditions	Symbol	Typical	Unit
Deep Power-Down	VIN = VCCQ or 0V; VCC, VCCQ = 1.95V; +85°C	IZZ	10	μA

Note:

Typical (TYP) IZZ value applies across all operating temperatures and voltages.

9.4 Partial Array Self Refresh Standby Current

Description	Conditions	Symbol	Array Partition	Max	Unit	
Partial-array refresh Standby current	VIN = VCCQ or 0V, CE# = VCCQ	IPAR	Standard power (no designation)	Full	400	μA
				1/2	330	
				1/4	300	
				1/8	280	
				0	250	

9.5 Capacitance

Description	Conditions	Symbol	Min	Max	Unit	Note
Input Capacitance	TC = +25°C; f = 1 MHz; VIN = 0V	CIN	2.0	6	pF	1
Input / Output Capacitance (A/DQ)		CIO	3.0	6.5	pF	1

Note 1: These parameters are verified in device characterization and are not 100% tested.

9.6 AC Input-Output Reference Wave form

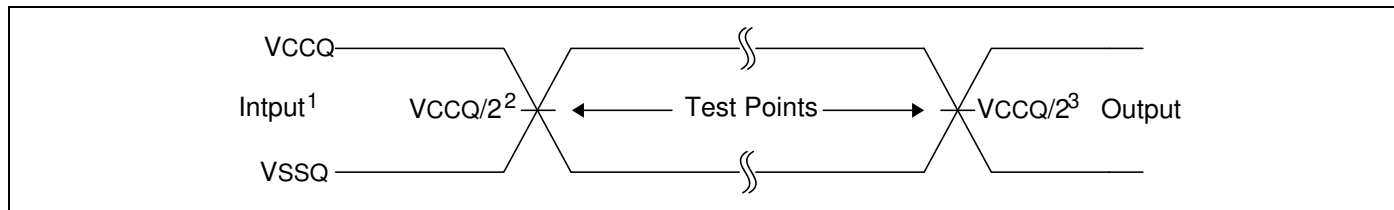

Notes:

1. AC test inputs are driven at VCCQ for a logic 1 and VSSQ for a logic 0. Input rise and fall times (10% to 90%) < 1.6ns.
2. Input timing begins at VCCQ/2.
3. Output timing ends at VCCQ/2.

9.7 AC Output Load Circuit

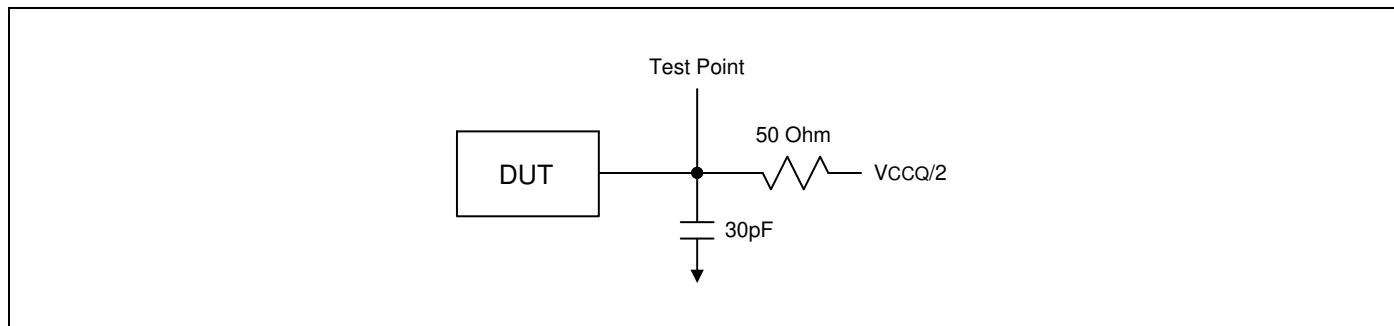

Note:

All tests are performed with the outputs configured for default setting of half drive strength (BCR[5:4] = 01b).



10. TIMING REQUIREMENTS

10.1 Read, Write Timing Requirements

10.1.1 Asynchronous READ Cycle Timing Requirements

All tests performed with outputs configured for default setting of half drive strength, (BCR[5:4] = 01b).

Parameter	Symbol	Min	Max	Unit	Note
Address access time	tAA		70	ns	
ADV# access time	tAADV		70	ns	
Address hold from ADV# HIGH	tAVH	2		ns	
Address setup to ADV# HIGH	tAVS	5		ns	
LB#/UB# access time	tBA		70	ns	
LB#/UB# disable to DQ High-Z Output	tBHZ		7	ns	1
Chip select access time	tCO		70	ns	
CE# LOW to ADV# HIGH	tCVS	7		ns	
Chip disable to DQ and WAIT High-Z output	tHZ		7	ns	1
Output enable to valid output	tOE		20	ns	
OE# LOW to WAIT valid	tOEW	1	7.5	ns	
Output disable to DQ High-Z output	tOHZ		7	ns	1
Output enable to Low-Z output	tOLZ	3		ns	2
ADV# pulse width	tVP	5		ns	

Notes:

1. Low-Z to High-Z timings are tested with AC Output Load Circuit. The High-Z timings measure a 100mV transition from either V_{OH} or V_{OL} toward V_{CCQ/2}.
2. High-Z to Low-Z timings are tested with the circuit. The Low-Z timings measure a 100mV transition away from the High-Z (V_{CCQ/2}) level toward either V_{OH} or V_{OL}.



10.1.2 Burst READ Cycle Timing Requirements

All tests performed with outputs configured for default setting of half drive strength, (BCR[5:4] = 01b).

Parameter	Symbol	133MHz		104MHz		Unit	Note
		Min	Max	Min	Max		
Address access time (fixed latency)	tAA		70		70	ns	
ADV# access time (fixed latency)	tAADV		70		70	ns	
Burst to READ access time (variable latency)	tABA		35.5		35.9	ns	
CLK to output delay	tACLK		5.5		7	ns	
Address hold from ADV# HIGH (fixed latency)	tAVH	2		2		ns	
Burst OE# LOW to output delay	tBOE		20		20	ns	
CE# HIGH between subsequent burst or mixed-mode operations	tCBPH	5		5		ns	1
Maximum CE# pulse width	tCEM		4		4	μs	1
CLK period	tCLK	7.5		9.62		ns	
Chip select access time (fixed latency)	tCO		70		70	ns	
CE# setup time to active CLK edge	tCSP	2.5		3		ns	
Hold time from active CLK edge	tHD	1.5		2		ns	
Chip disable to DQ and WAIT High-Z output	tHZ		7		7	ns	2
CLK rise or fall time	tKHKL		1.2		1.6	ns	
CLK to WAIT valid	tKHTL		5.5		7	ns	
Output HOLD from CLK	tKOH	2		2		ns	
CLK HIGH or LOW time	tKP	3		3		ns	
Output disable to DQ High-Z output	tOHZ		7		7	ns	2
Output enable to Low-Z output	tOLZ	3		3		ns	3
Setup time to active CLK edge	tSP	2		3		ns	

Notes:

1. A refresh opportunity must be provided every tCEM. A refresh opportunity is satisfied by either of the following two conditions: a) clocked CE# HIGH, or b) CE# HIGH for longer than 15ns.
2. Low-Z to High-Z timings are tested with the circuit. The High-Z timings measure a 100mV transition from either VOH or VOL toward VccQ/2.
3. High-Z to Low-Z timings are tested with the circuit. The Low-Z timings measure a 100mV transition away from the High-Z (VccQ/2) level toward either VOH or VOL.



10.1.3 Asynchronous WRITE Cycle Timing Requirements

Parameter	Symbol	Min	Max	Unit	Note
Address and ADV# LOW setup time	tAS	0		ns	
Address HOLD from ADV# going HIGH	tAVH	2		ns	
Address setup to ADV# going HIGH	tAVS	5		ns	
Address valid to end of WRITE	tAW	70		ns	
LB#/UB# select to end of WRITE	tBW	70		ns	
CE# HIGH between subsequent asynchronous operations	tCPH	5		ns	
CE# LOW to ADV# HIGH	tCVS	7		ns	
Chip enable to end of WRITE	tCW	70		ns	
Data HOLD from WRITE time	tDH	0		ns	
Data WRITE setup time	tDW	20		ns	
Chip disable to WAIT High-Z output	tHZ		7	ns	1
ADV# pulse width	tVP	5		ns	
ADV# setup to end of WRITE	tVS	70		ns	
WRITE pulse width	tWP	45		ns	2
WRITE recovery time	tWR	0		ns	

Notes:

1. Low-Z to High-Z timings are tested with AC Output Load Circuit. The High-Z timings measure a 100mV transition from either V_{OH} or V_{OL} toward V_{CCQ}/2.
2. WE# LOW time must be limited to t_{CEM} (4μs).



10.1.4 Burst WRITE Cycle Timing Requirements

Parameter	Symbol	133MHz		104MHz		Unit	Note
		Min	Max	Min	Max		
Address and ADV# LOW setup time	tAS	0		0		ns	1
Address HOLD from ADV# HIGH (fixed latency)	tAVH	2		2		ns	
CE# HIGH between subsequent burst or mixed-mode operations	tCBPH	5		5		ns	2
Maximum CE# pulse width	tCEM		4		4	μs	2
Clock period	tCLK	7.5		9.62		ns	
CE# setup to CLK active edge	tCSP	2.5		3		ns	
Hold time from active CLK edge	tHD	1.5		2		ns	
Chip disable to WAIT High-Z output	tHZ		7		7	ns	3
CLK rise or fall time	tKHKL		1.2		1.6	ns	
Clock to WAIT valid	tKHTL		5.5		7	ns	
Output HOLD from CLK	tKOH	2		2		ns	
CLK HIGH or LOW time	tKP	3		3		ns	
Setup time to activate CLK edge	tSP	2		3		ns	

Notes:

- tAS required if tCSP > 20ns.
- A refresh opportunity must be provided every tCEM. A refresh opportunity is satisfied by either of the following two conditions:
 - clocked CE# HIGH, or
 - CE# HIGH for longer than 15ns.
- Low-Z to High-Z timings are tested with the circuit. The High-Z timings measure a 100mV transition from either VOH or VOL toward VccQ/2.



10.2 TIMING DIAGRAMS

10.2.1 Initialization Period

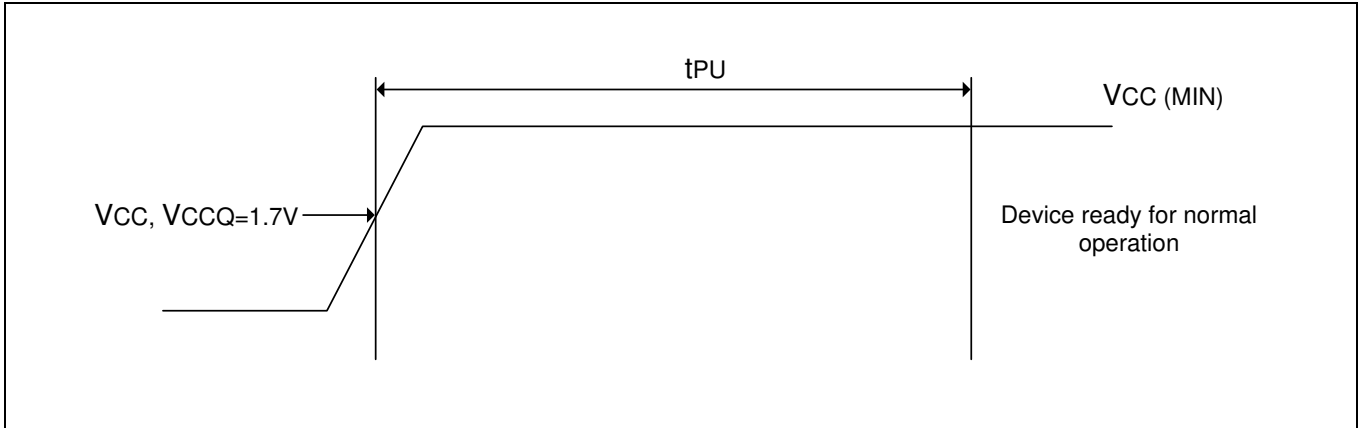

10.2.2 DPD Entry and Exit Timing Parameters

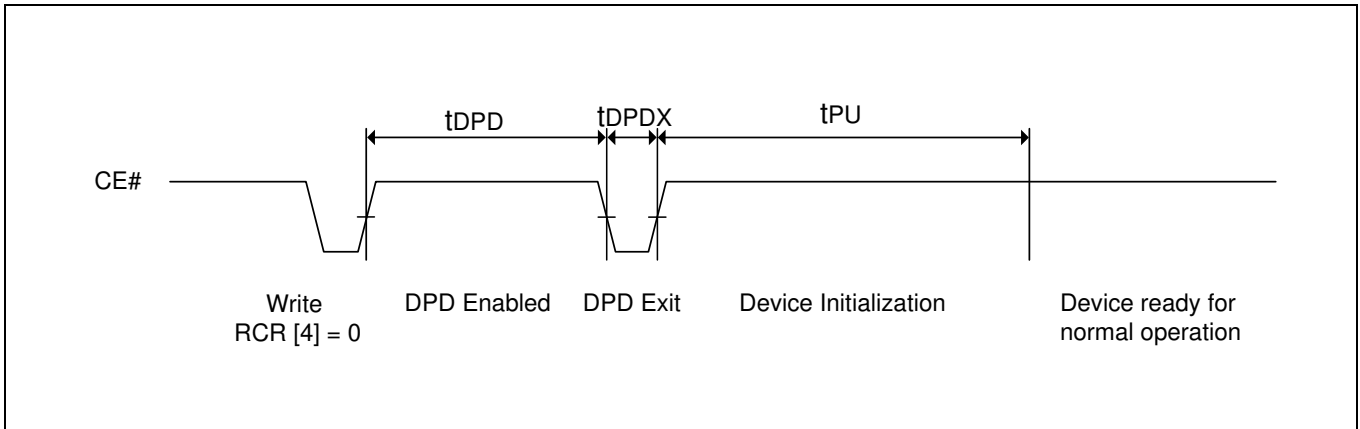

10.2.3 Initialization and DPD Timing Parameters

Description	Symbol	Min	Max	Unit
CE# HIGH after Write RCR[4]=0	tDPD	150	-	μs
CE# LOW between DPD Enable and Device Initialization	tDPDX	10	-	μs
DPD Exit to next Operation Command	tPU	-	150	μs



10.2.4 Asynchronous READ

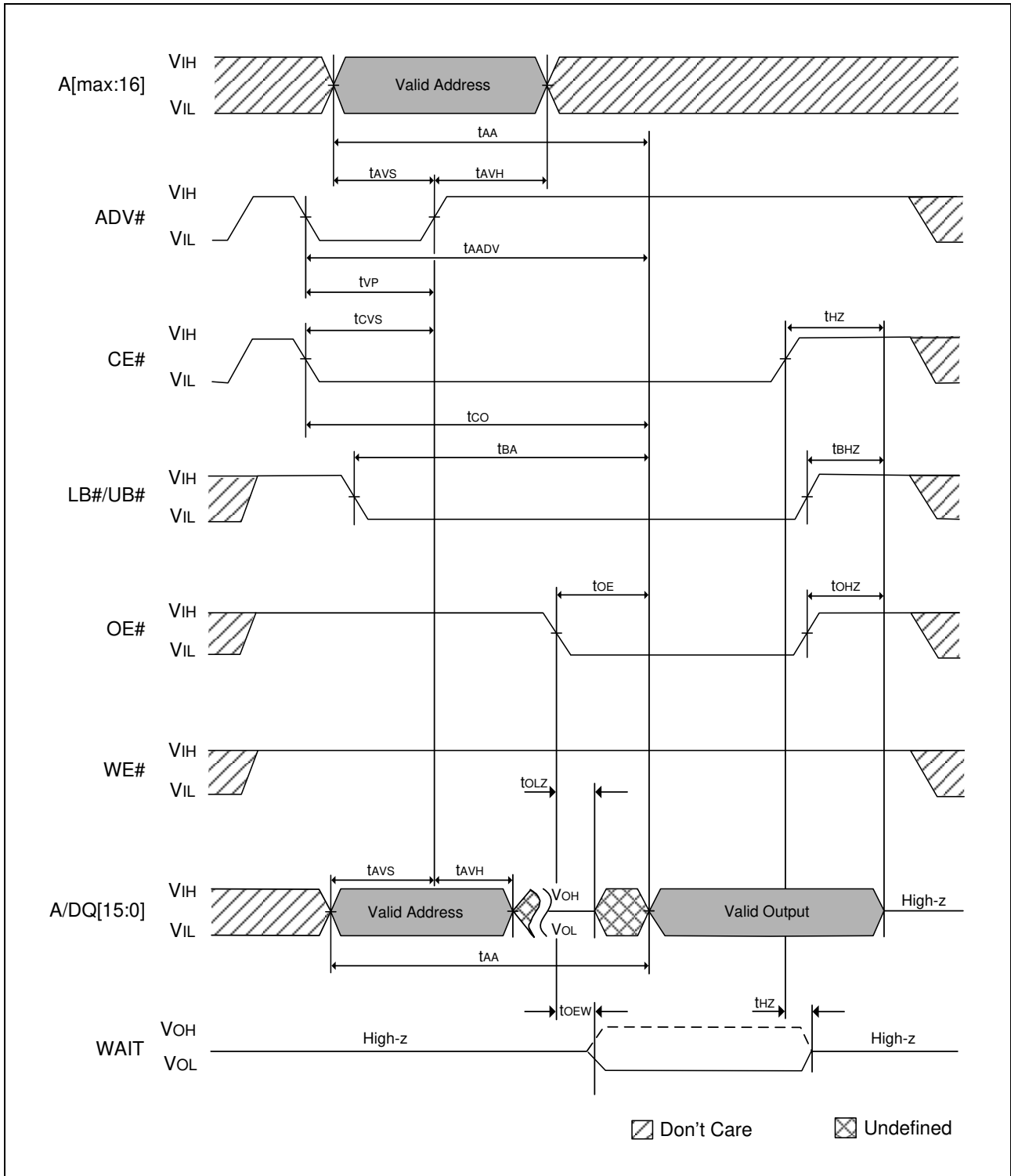



10.2.5 Single Access Burst READ Operation - Variable Latency

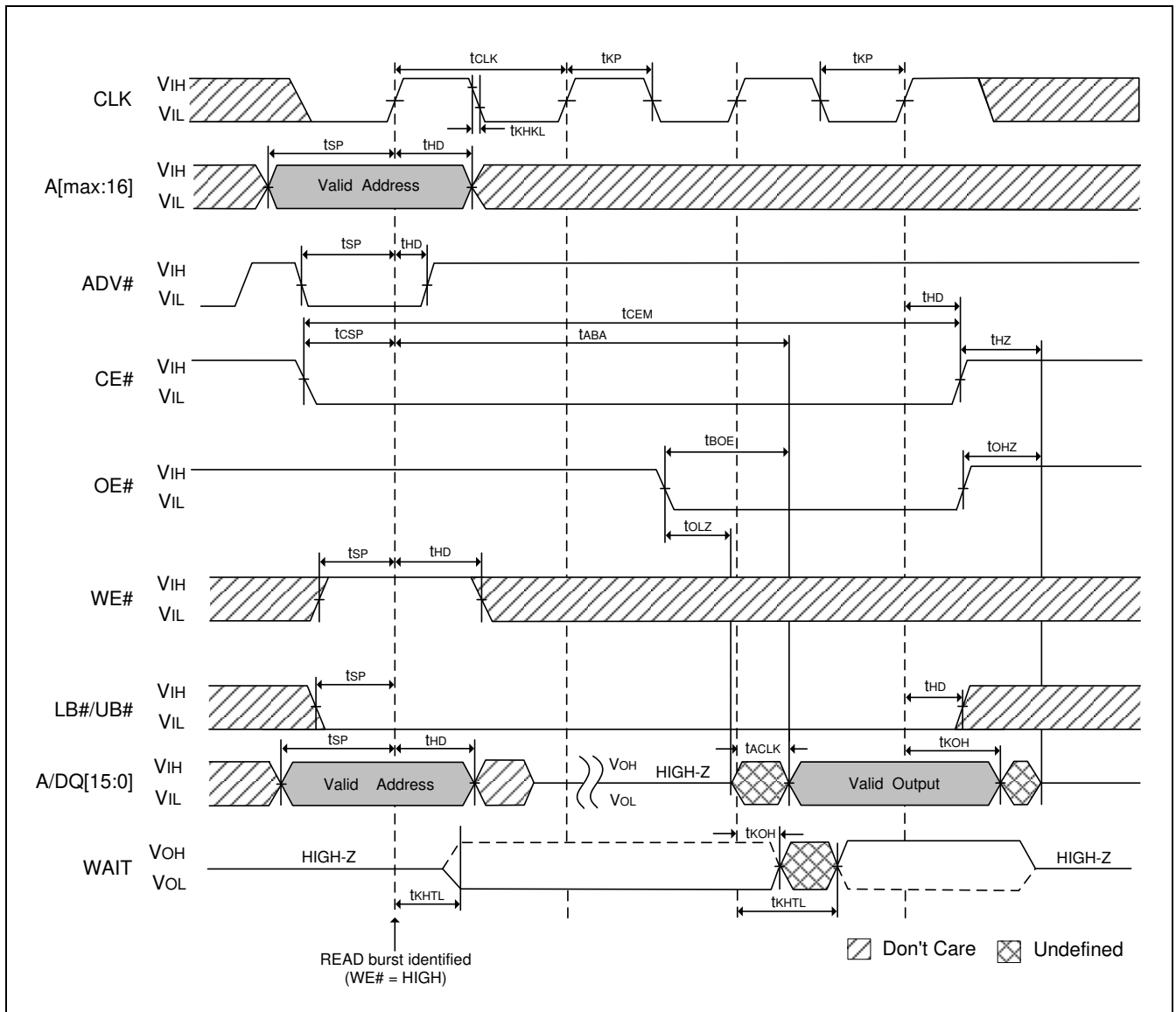

Note:

Non-default BCR settings: latency code 2 (3 clocks), WAIT active LOW, WAIT asserted during delay.



10.2.7 Single-Access Burst READ Operation-Fixed Latency

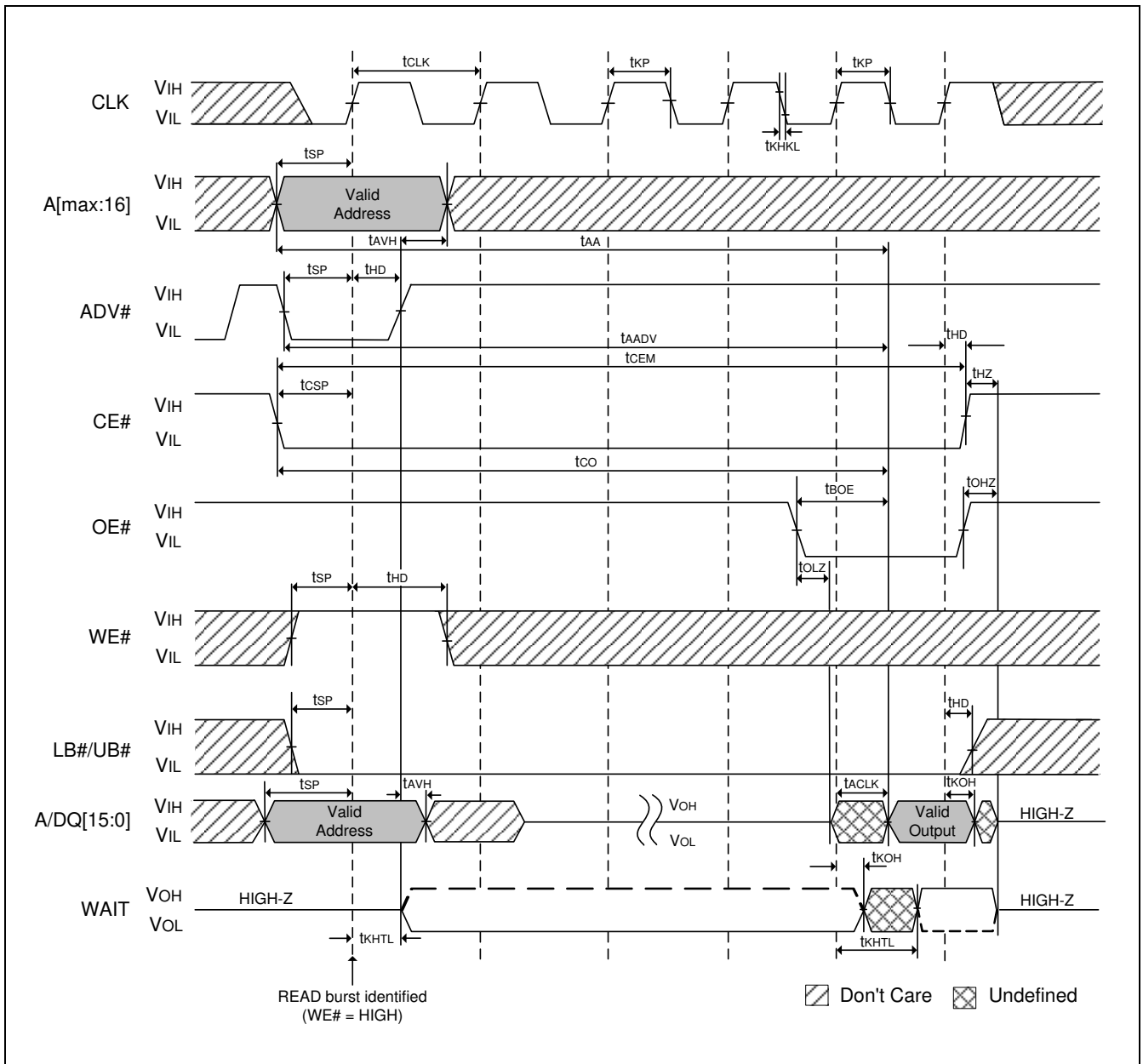

Note:

Non-default BCR settings: fixed latency, latency code 4 (5 clocks), WAIT active LOW, WAIT asserted during delay.



10.2.8 Four Word Burst READ Operation-Fixed Latency

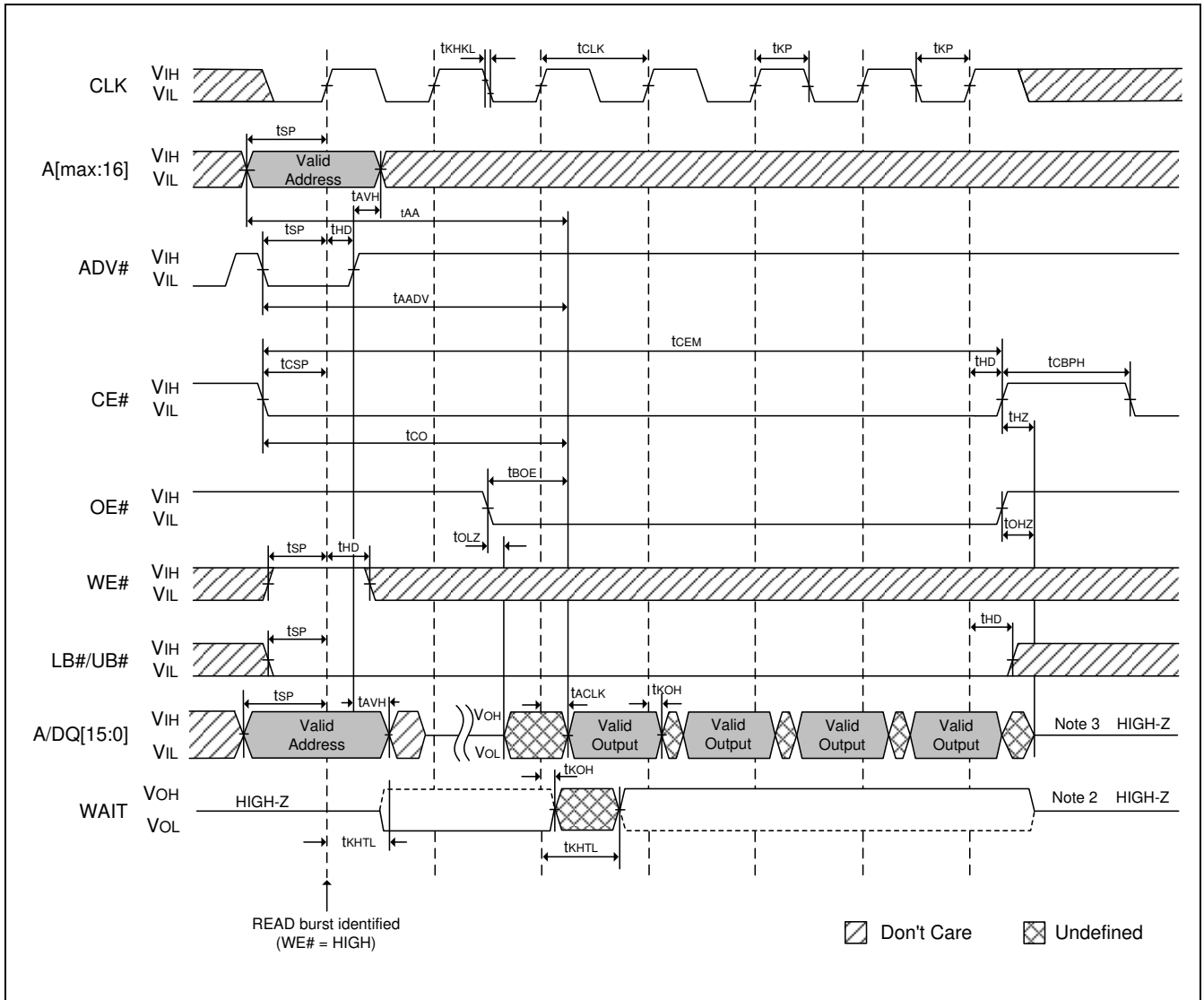

Notes:

1. Non-default BCR settings: fixed latency, latency code 2 (3 clocks), WAIT active LOW, WAIT asserted during delay.
2. WAIT will remain de-asserted even if CE# remains LOW past the end of the defined burst length.
3. A/DQ[15:0] will output undefined data if CE# remains LOW past the end of the defined burst length.



10.2.9 Burst READ Terminate at End-of-Row (Wrap Off)

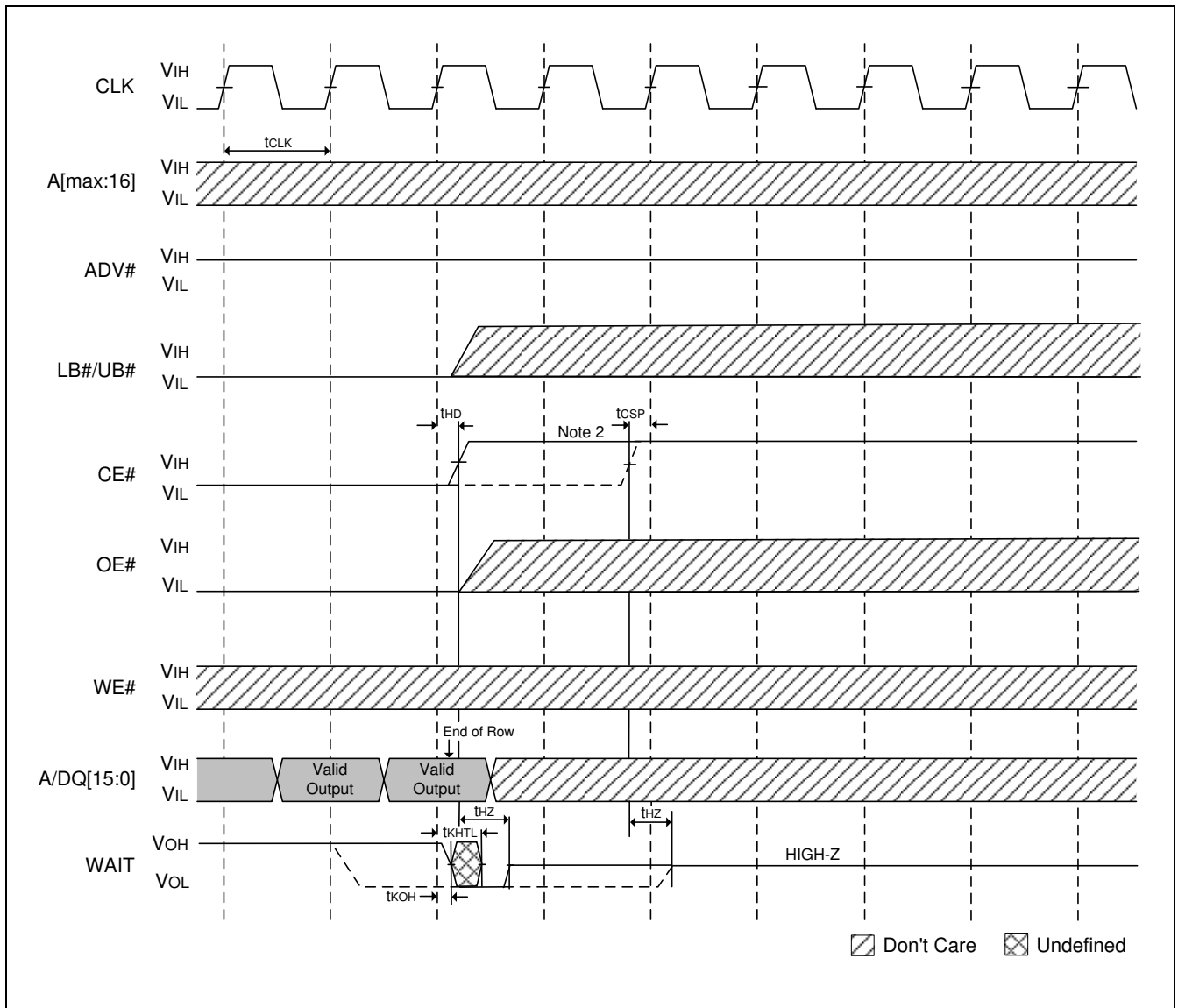

Notes:

1. Non-default BCR settings for burst READ at end of row: fixed or variable latency, WAIT active LOW, WAIT asserted during delay (shown as solid line).
2. For burst READs, CE# must go HIGH before the second CLK after the WAIT period begins (before the second CLK after WAIT asserts with BCR[8] = 0, or before the third CLK after WAIT asserts with BCR[8] = 1).



10.2.10 Burst READ Row Boundary Crossing

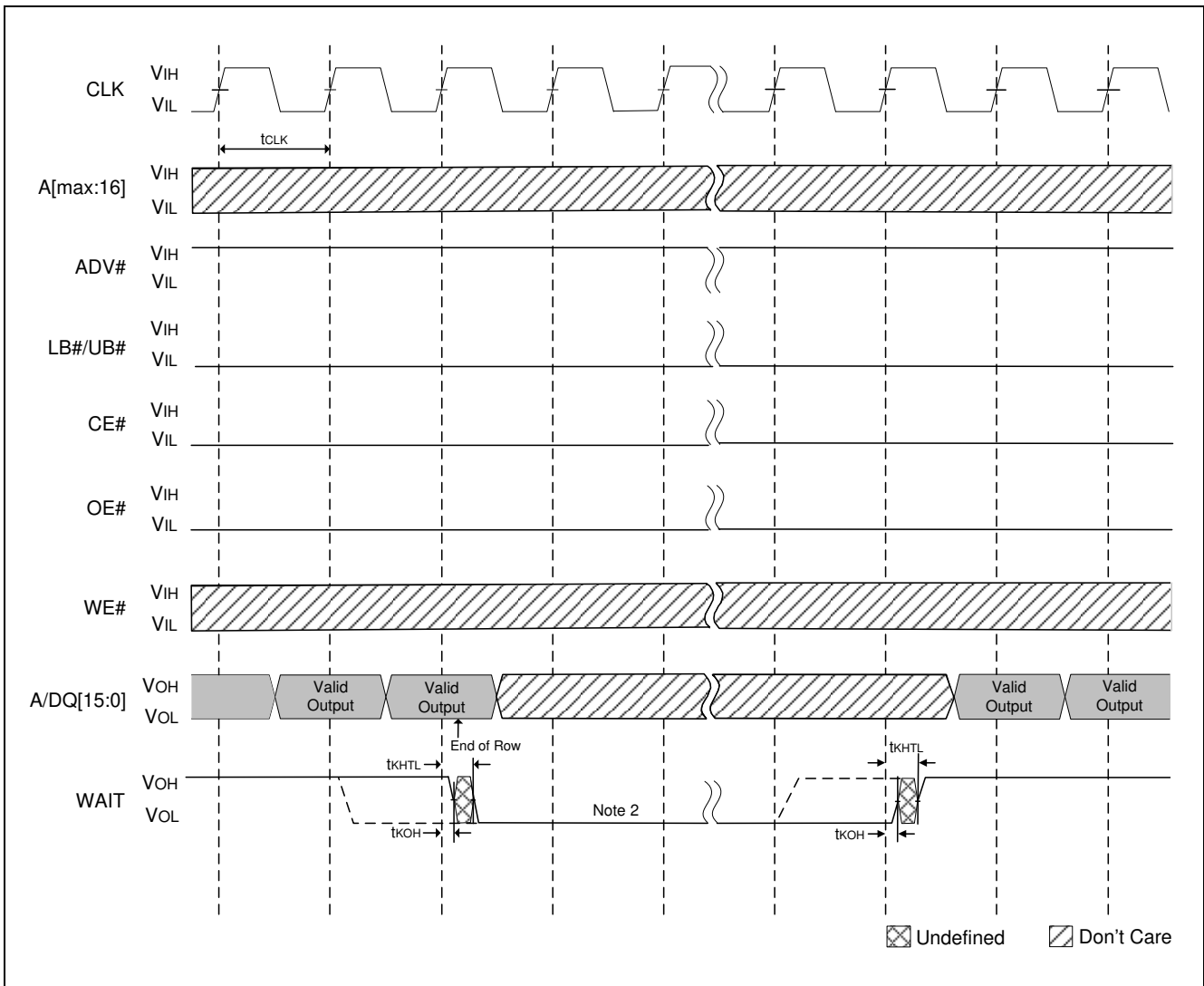

Notes:

1. Non-default BCR settings for burst READ at end of row: fixed or variable latency, WAIT active LOW, WAIT asserted during delay (shown as solid line).
2. WAIT will be asserted LC+1 cycles for fixed latency, LC = Latency code (BCR[13:11]).



10.2.11 Asynchronous WRITE

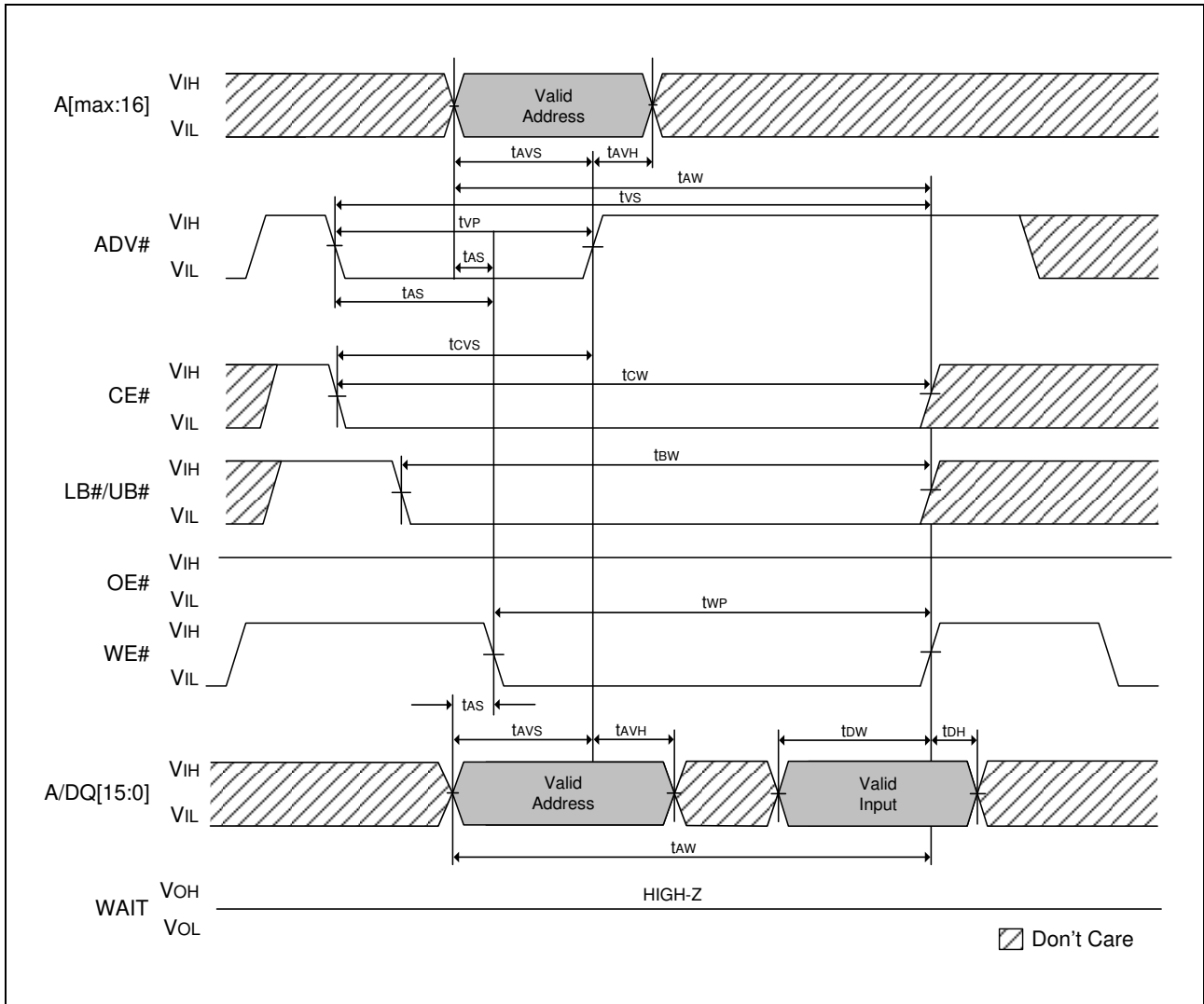



10.2.12 Burst WRITE Operation—Variable Latency Mode

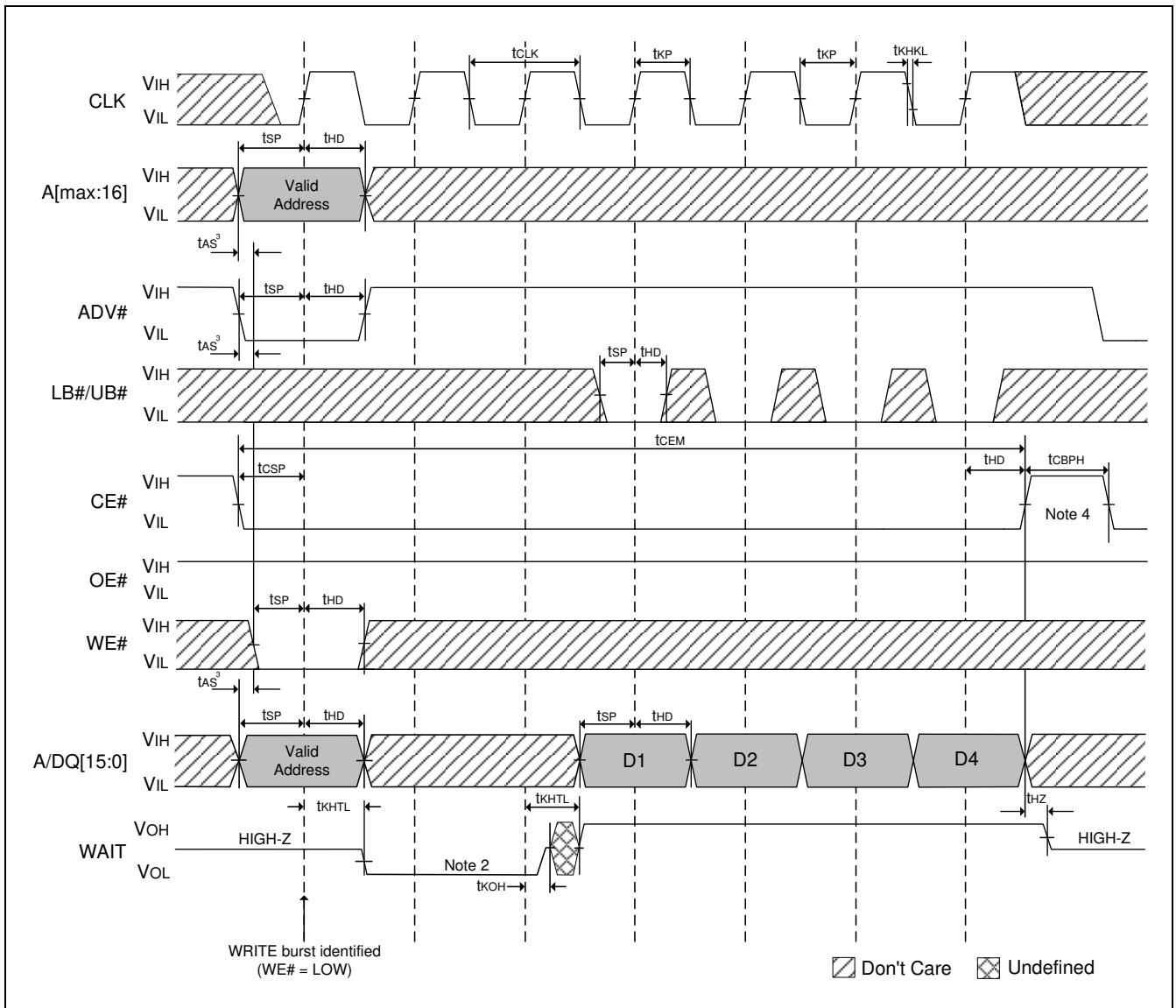

Notes:

1. Non-default BCR settings for burst WRITE operation in variable latency mode: latency code 2 (3 clocks), WAIT active LOW, WAIT asserted during delay, burst length 4, burst wrap enabled.
2. WAIT asserts for LC cycles for both fixed and variable latency. LC = latency code (BCR[13:11]).
3. t_{AS} is required if t_{CSP} > 20ns.
4. CE# must go HIGH before any clock edge following the last word of a defined-length burst.



10.2.13 Burst WRITE Operation-Fixed Latency Mode

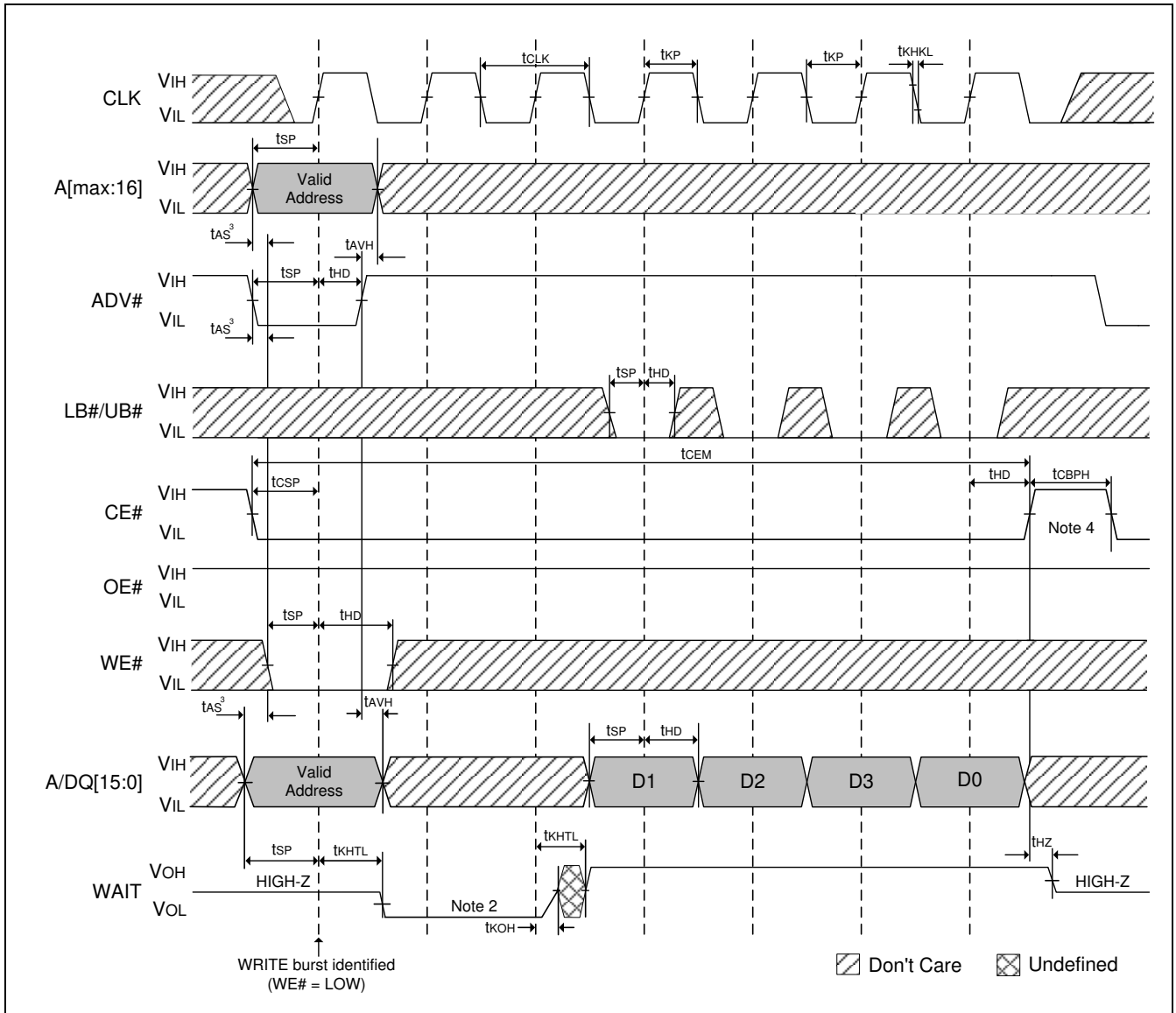

Notes:

1. Non-default BCR settings for burst WRITE operation in fixed latency mode: fixed latency, latency code 2 (3 clocks), WAIT active LOW, WAIT asserted during delay, burst length 4, burst wrap enabled.
2. WAIT asserts for LC cycles for both fixed and variable latency. LC = latency code (BCR[13:11]).
3. t_{AS} is required if $t_{CSP} > 20ns$.
4. CE# must go HIGH before any clock edge following the last word of a defined-length burst.



10.2.14 Burst WRITE Terminate at End of Row (Wrap Off)

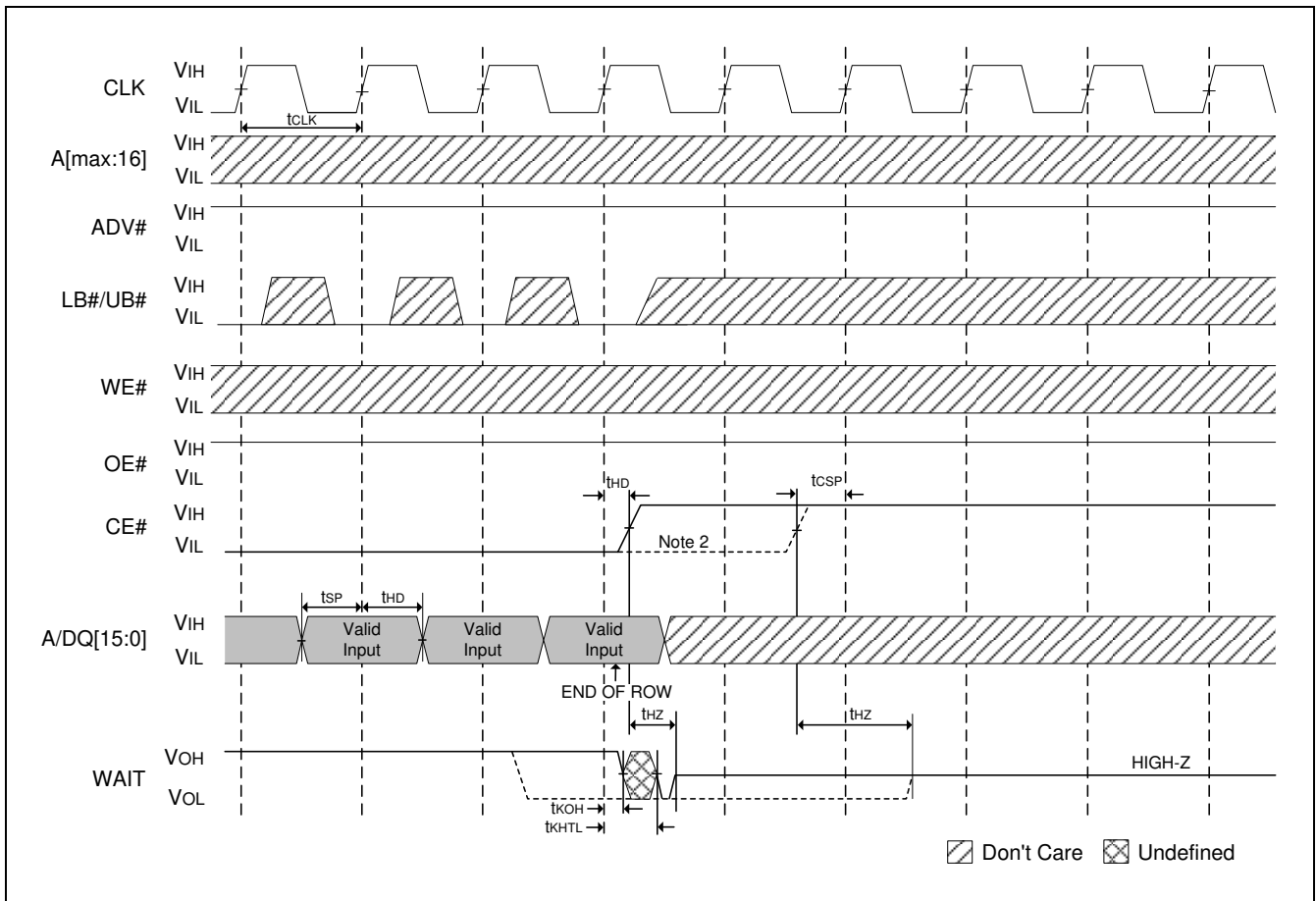

Notes:

1. Non-default BCR settings for burst WRITE at end of row: fixed or variable latency, WAIT active LOW, WAIT asserted during delay (shown as solid line).
2. For burst WRITES, CE# must go HIGH before the second CLK after the WAIT period begins (before the second CLK after WAIT asserts with BCR[8] = 0, or before the third CLK after WAIT asserts with BCR[8] = 1).



10.2.15 Burst WRITE Row Boundary Crossing

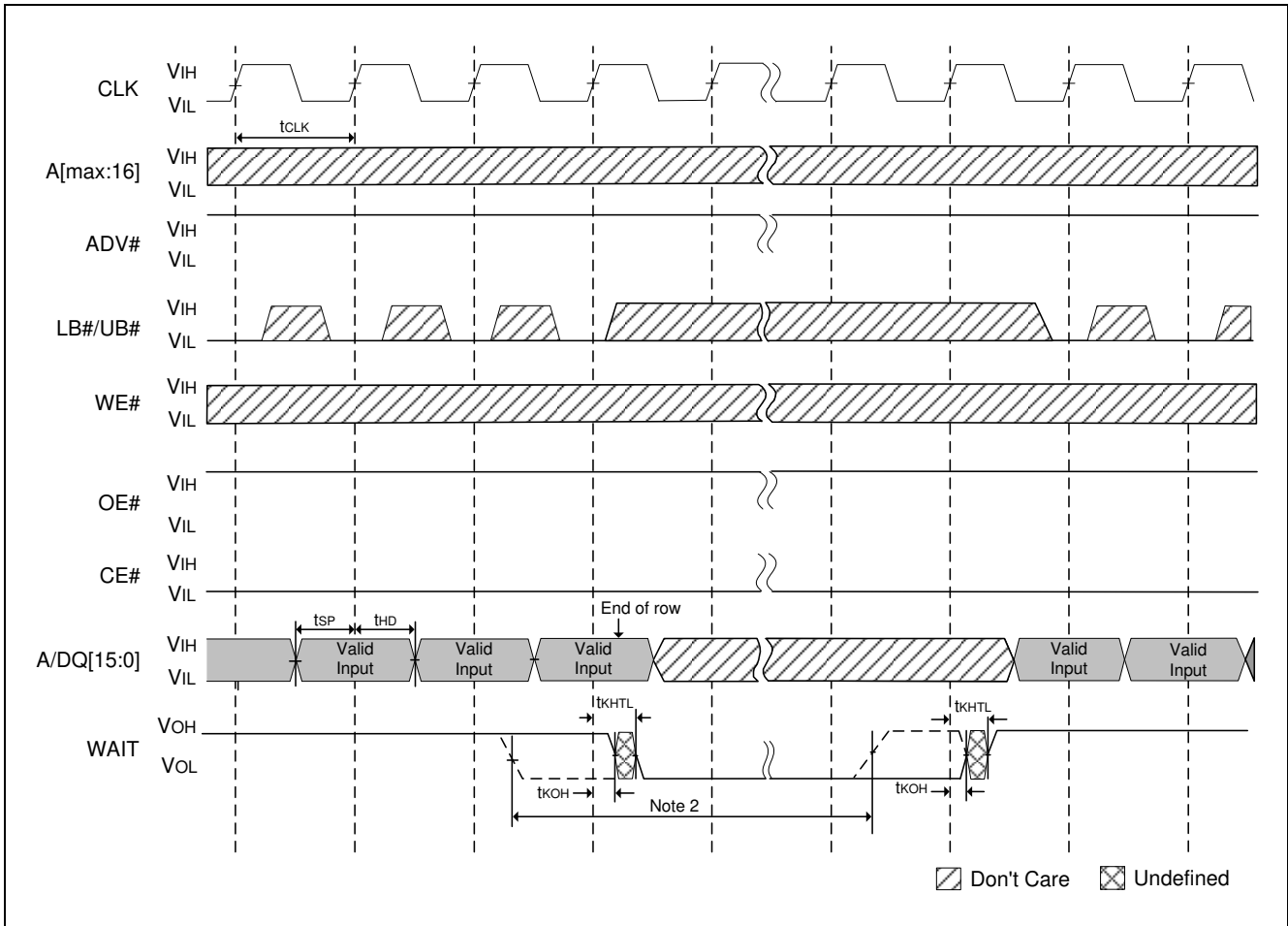

Notes:

1. Non-default BCR settings for burst WRITE at end of row: fixed or variable latency, WAIT active LOW, WAIT asserted during delay (shown as solid line).
2. WAIT will be asserted LC cycles for variable latency or fixed latency.



10.2.16 Burst WRITE Followed by Burst READ

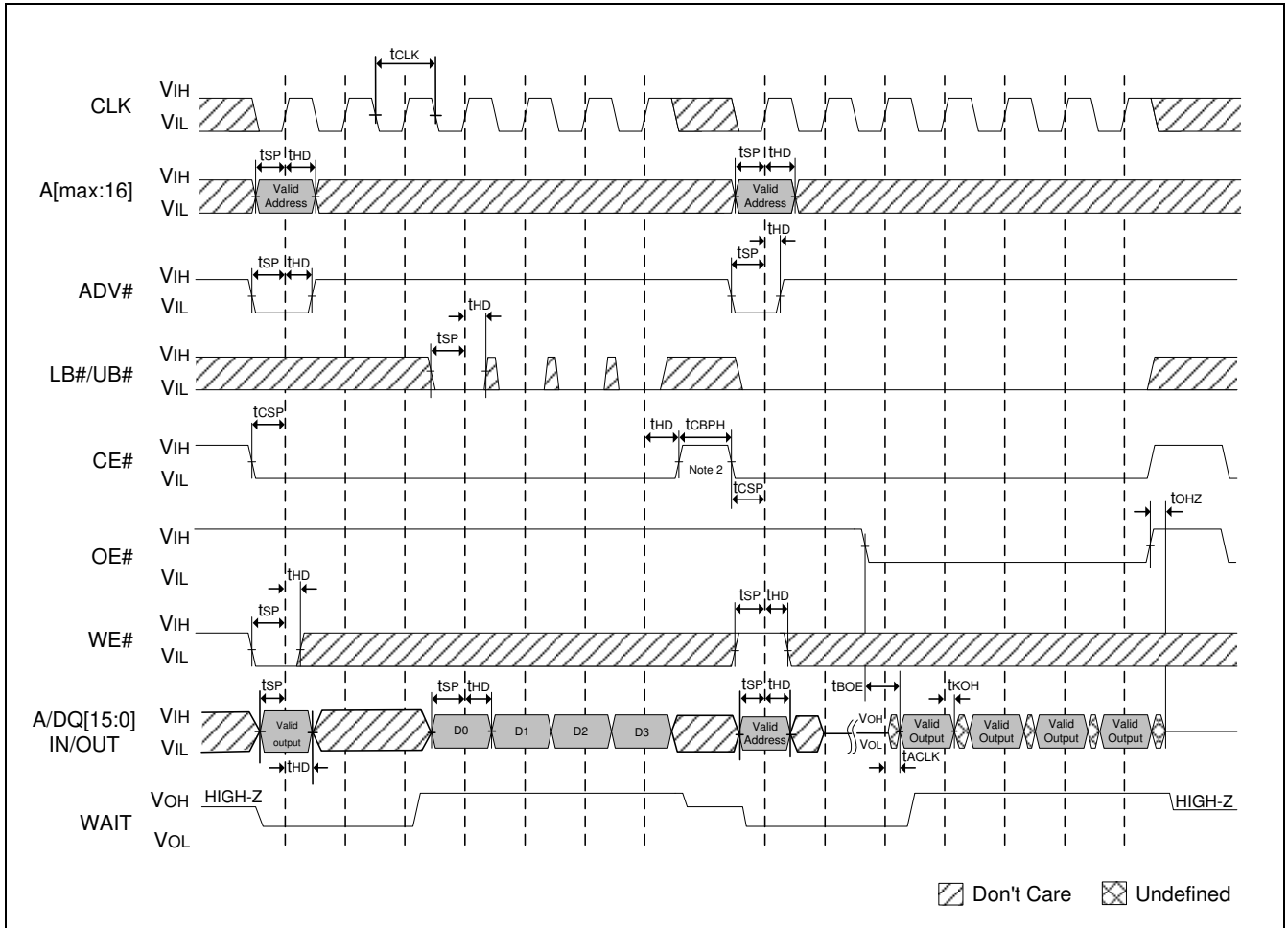

Notes:

1. Non-default BCR settings for burst WRITE followed by burst READ: fixed or variable latency, latency code 2 (3 clocks), WAIT active LOW, WAIT asserted during delay.
2. A refresh opportunity must be provided every t_{CEM} . A refresh opportunity is satisfied by either of the following two conditions: a) clocked CE# HIGH, or b) CE# HIGH for longer than 15ns.



10.2.17 Asynchronous WRITE Followed by Burst READ

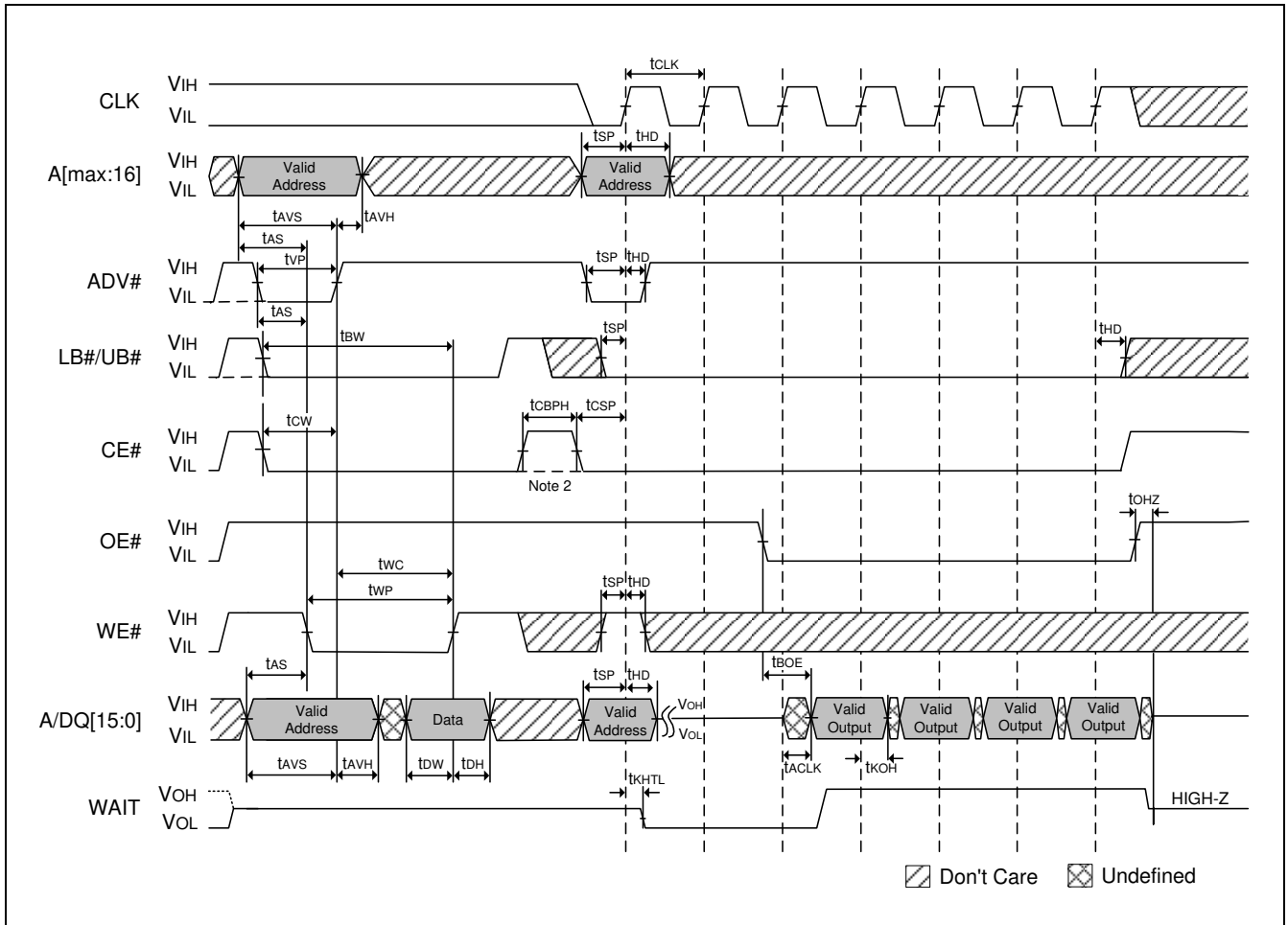

Notes:

1. Non-default BCR settings for asynchronous WRITE, with ADV# LOW, followed by burst READ: fixed or variable latency, latency code 2 (3 clocks), WAIT active LOW, WAIT asserted during delay.
2. When the device is transitioning between asynchronous and variable-latency burst operations, CE# must go HIGH. CE# can stay LOW when the device is transitioning to fixed-latency burst READS. A refresh opportunity must be provided every t_{CEM} . A refresh opportunity is satisfied by either of the following two conditions: a) clocked CE# HIGH, or b) CE# HIGH for longer than 15ns.



11. PACKAGE DESCRIPTION

11.1 Package Dimension

VFBGA 54Ball (6x8 mm², Ball pitch: 0.75mm, Ø=0.4mm)

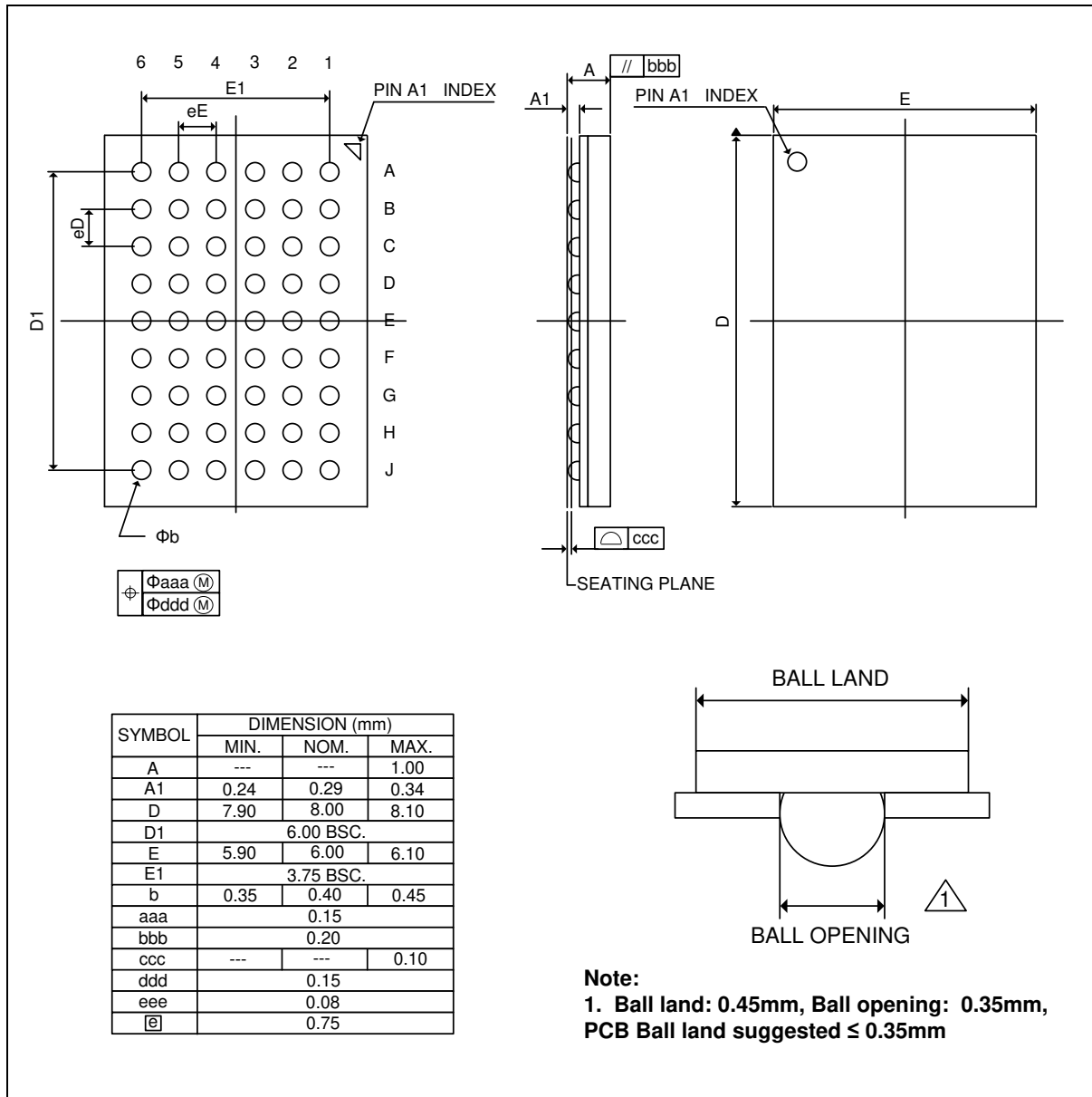



12. REVISION HISTORY

Version	Date	Page	Description
A01-001	Feb. 21, 2013	All	Create new document
A01-002	Mar. 26, 2013	2 1~38	Update ordering information Add DPD mode
A01-003	Jun. 27, 2013	32	Remove note 6 in section 9.2
A01-004	Feb. 17, 2020	All 8 19 20 34 25, 29, 36 43 52 54	Refine format Refine 8.1.1 power-up initialization timing waveform diagram Update 8.4.2.1 Load Configuration Register timing waveform diagram Update 8.4.2.2 Read Configuration Register timing waveform diagram Removing redundant tWHZ parameter Correcting typos Revise note2 of 10.2.10 Burst READ Row Boundary Crossing Correcting typo in 10.2.19 timing diagram (change tDS to tDW) Remove "Important Notice"

*Please note that all data and specifications are subject to change without notice.
All the trademarks of products and companies mentioned in this datasheet belong to their respective owners.*

*Publication Release Date: Feb. 17, 2020
Revision: A01-004*