

P	LTR	DESCRIPTION	DATE	DWN	APVD
B2		REVISED PER ECN-21-129868	23NOV2021	DRK	NRS
B3		REVISED PER ECR-21-124520	06JAN2022	NS	CB
B4		REVISED PER ECR-22-132933	18MAR2022	FC	CB

NOTES:

- 1 FINISH: PLATE 0.000100-0.000200 THK TIN IN LOCALIZED TIN PLATE AREA, ALL OVER 0.000040-0.000080 THK NICKEL.
- 2. CONTACT WILL BE LUBED WITH LUBRICANT PER TE CONNECTIVITY P/N 22014-4.
- 3. WIRE RANGE: 20-18 AWG WITH ISLUATION DIAMETERS OF 0.050-0.107 INCHES.
- 4 PLATE 0.000030 MIN THK SELECT GOLD IN LOCALIZED PLATE AREA. TIP PLATING AREA PLATE TO 0.000015 MIN THK.

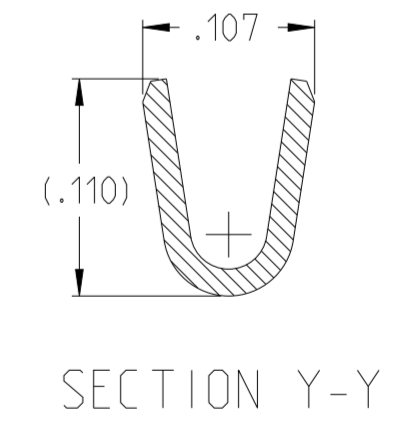
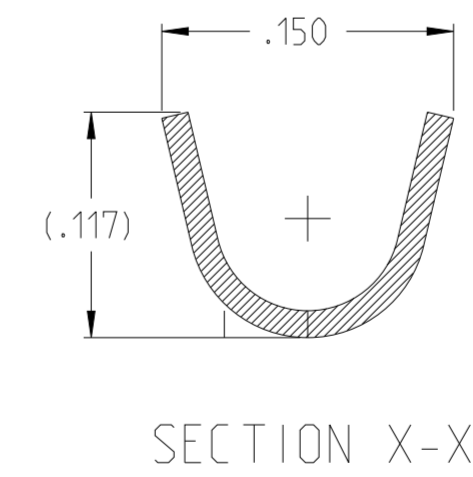
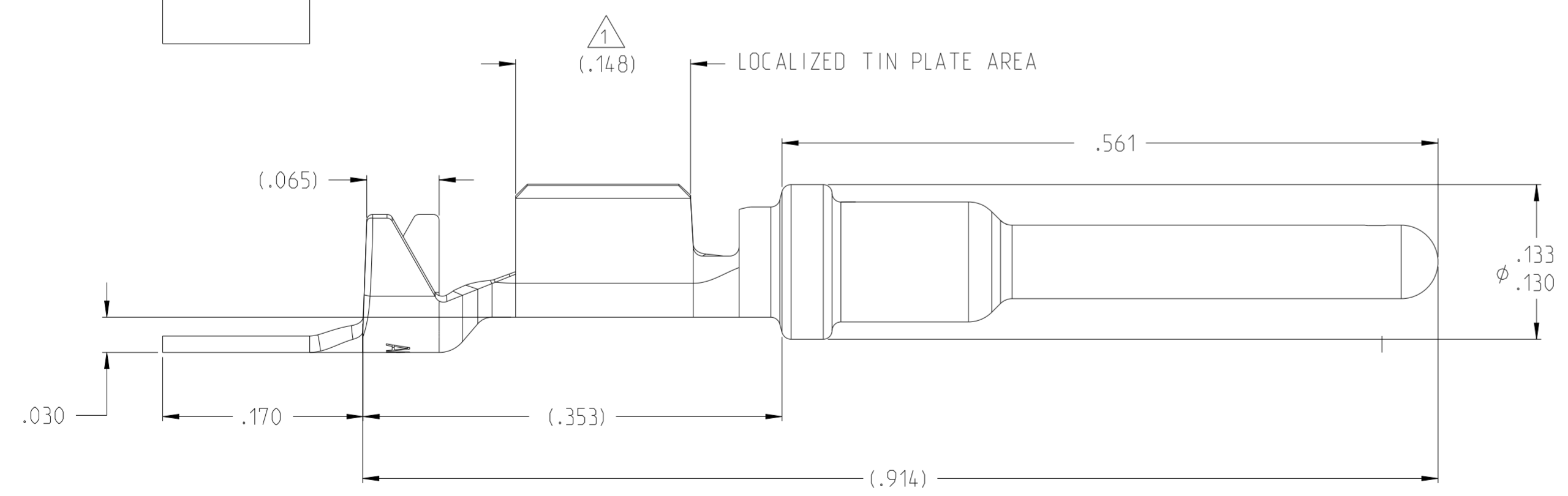
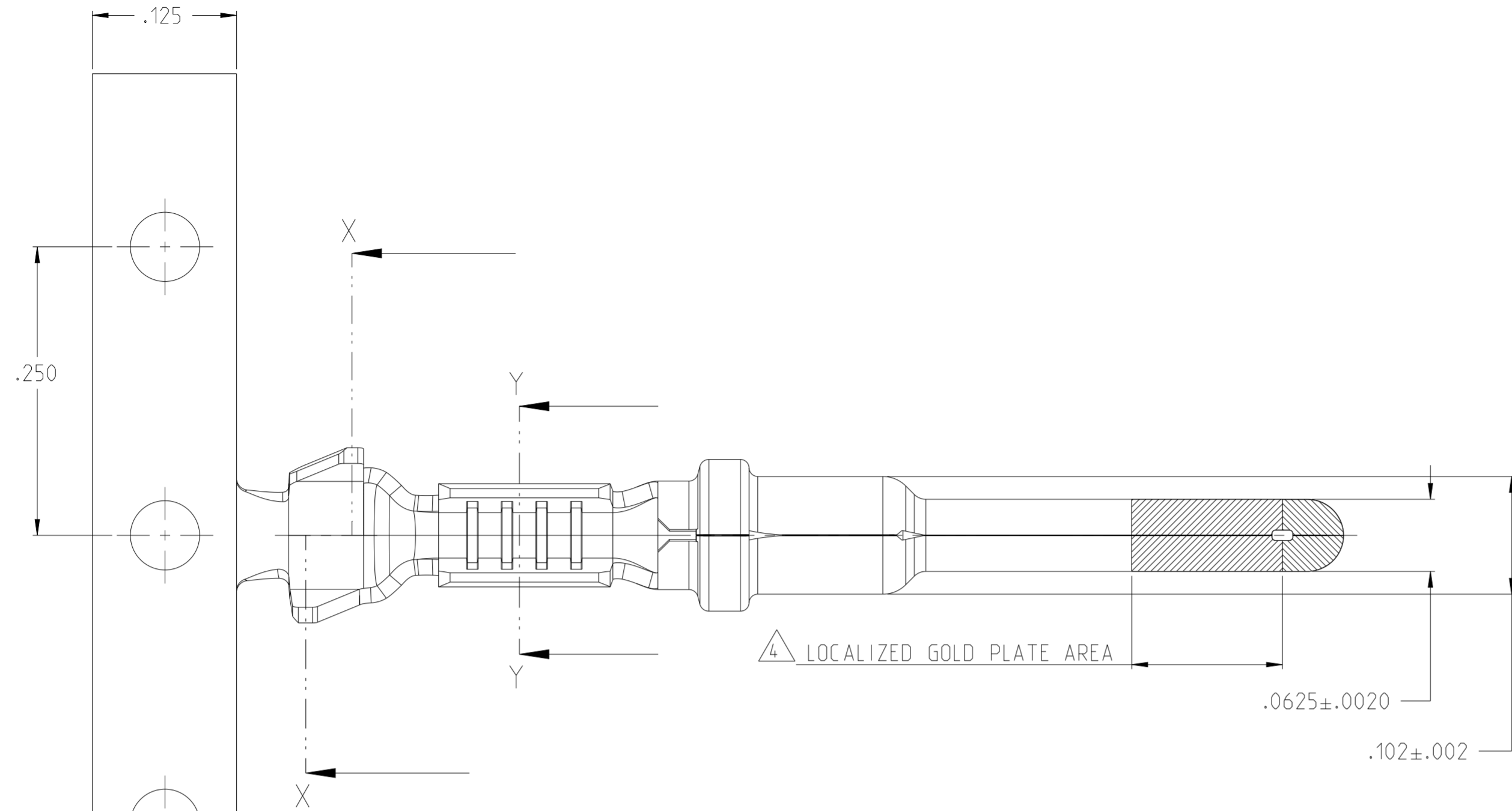

1	1924463-3
1 4	1924463-1
FINISH	PART NUMBER

THIS DRAWING IS A CONTROLLED DOCUMENT.

DWN DL DRUMMOND 27AUG2007	TE Connectivity <b>PIN CONTACT</b>
CHK MP TRULL 27AUG2007	
APVD MP TRULL 27AUG2007	
PRODUCT SPEC	
APPLICATION SPEC	
WEIGHT	
CUSTOMER DRAWING	

SIZE	CAGE CODE	DRAWING NO	RESTRICTED TO
A2	00779	1924463	-
SCALE	10:1	SHEET	1 OF 1
			REV B4