

REV.	DATE	ECR NO.	DESCRIPTION
A	05/01/04	XXXXXX	UPDATE DRAWING FORMAT
B	10/26/11	XXXXXX	CHANGE THE DIMENSION OF 3.58MM TO 3.28MM
C	11/03/11	2252	ADD THE DIMENSIONS

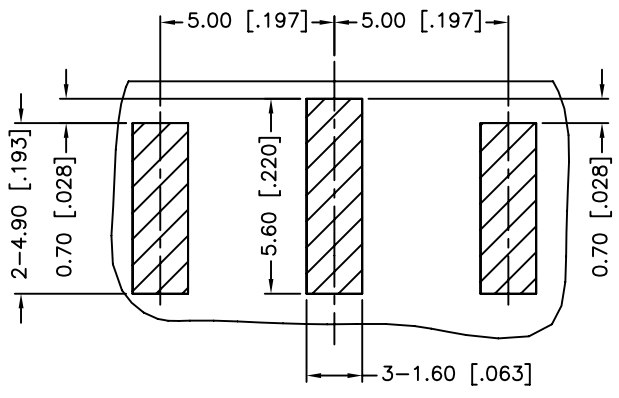

TOP VIEW

RECOMMENDED PCB LAYOUT

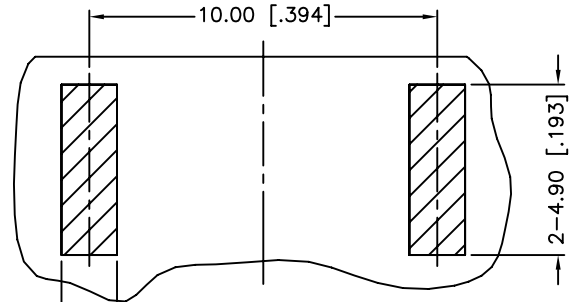

BOTTOM VIEW

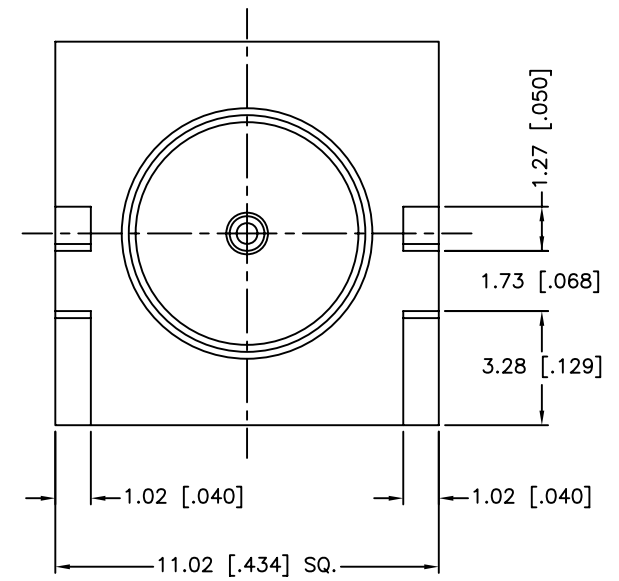
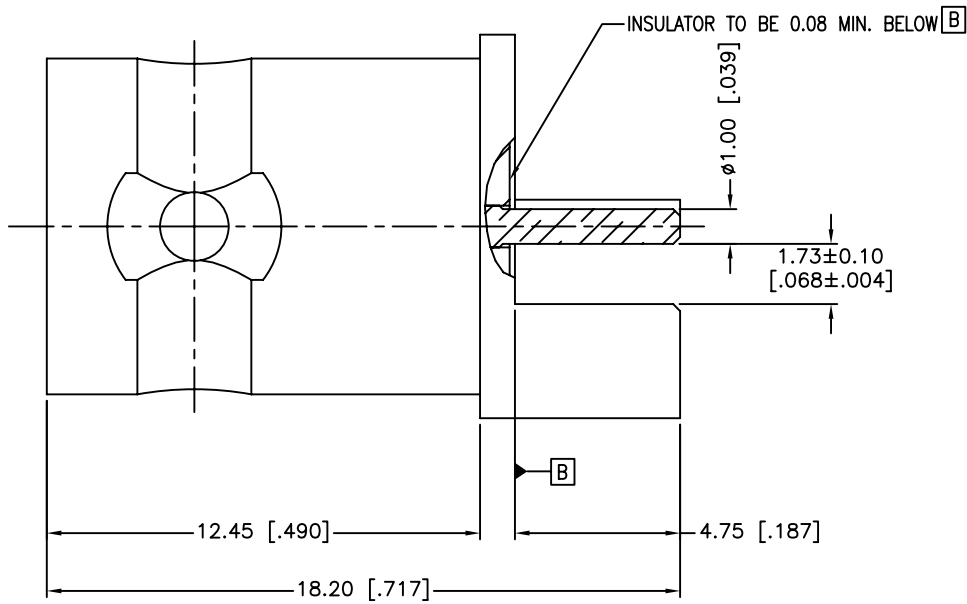
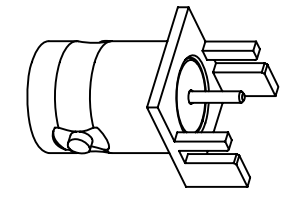

1. IMPEDANCE: 75 OHM
2. FREQUENCY RANGE: DC 0-3 GHZ
3. DIELECTRIC WITHSTANDING VOLTAGE: 1500 VRMS. MIN.
4. BOARD THICKNESS=1.57 MM [.062"]
5. DURABILITY: 500 CYCLES MIN.

UNLESS OTHERWISE SPECIFIED DIMENSIONS ARE IN MILLIMETERS. DIMENSIONS IN [] ARE IN INCHES AND FOR CUSTOMER REFERENCE ONLY.

UNLESS OTHERWISE SPECIFIED TOLERANCES FOR MILLIMETERS ARE:
0.5 - 8mm ± 0.20mm
8 - 30mm ± 0.40mm
30 - 120mm ± 0.50mm

UNLESS OTHERWISE SPECIFIED TOLERANCES FOR INCHES ARE:
.020 - .315 = ± 0.007"
.315 - 1.180 = ± 0.015"
1.180 - 4.724 = ± 0.020"

DO NOT SCALE DRAWING

APPROVALS		DATE
DRAWN	M.ZHANG	11/03/11
CHECKED		
ISSUED		
SHEET	1 OF 1	
CAD FILE	C:/CONNEX/112622.DWG	

Amphenol Connex

PART DESCRIPTION			
BNC END LAUNCH RECEPT. JACK - 75 OHM (FOR .062" BOARD THICKNESS)			
PART NO.		112622	
DWG. NO.	112622.DWG	REV.	C
SIZE	A	SCALE	NA

QTY	FINISH	MATERIAL	DESCRIPTION
1	NICKEL	BRASS	BODY
1	NATURAL	PTFE	INSULATOR
1	GOLD	PHOSPHOR BRONZE	CONTACT PIN