

Order Number
63816-1730

molex[®]

Application Tooling Specification

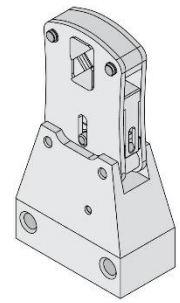

FEATURES

- The quick-change power crimp head is easily installed onto the battery crimp tool (Order No. 63816-0270 and 63816-0280) and electric crimping machine (Order No. 63816-1500)
- Powered crimp tools help reduce fatigue and discomfort from repetitive manual crimping

SCOPE

The 63816-1730 power crimp head was created for square ferrule crimps. It can be attached to the battery crimp tool (Order No. 63816-0270 and 63816-0280) and electric crimping machine (Order No. 63816-1500).

Products: Wire ferrules 0.25-10mm² (24-8 AWG).

Molex Ferrules

Ferrule	Color	AWG	mm2	Ø	d	P	L
936020004	Orange	22	0.35	2.6	0.8	6	12
936020005	White	22	0.35	2.6	0.8	6	12
936020006	Orange	22	0.35	2.6	0.8	8	14
936020007	White	22	0.35	2.6	0.8	8	14
936020008	White	22	0.35	2.6	0.8	10	16
936020001	White	20	0.5	2.6	1	6	12
936020002	White	20	0.5	2.6	1	8	14
936020003	White	20	0.5	2.6	1	10	16
936020009	Grey	18	0.75	2.8	1.2	6	12.4
936020010	White	18	0.75	2.8	1.2	6	12.4
936020011	Blue	18	0.75	2.8	1.2	8	14.6
936020012	Grey	18	0.75	2.8	1.2	8	14.6
936020013	White	18	0.75	2.8	1.2	8	14.6
936020014	Grey	18	0.75	2.8	1.2	10	16.4
936020015	Grey	18	0.75	2.8	1.2	12	18.4
936020016	White	18	0.75	2.8	1.2	12	18.4
936020017	Red	N/A	1	3	1.4	6	12.3
936020018	Yellow	N/A	1	3	1.4	6	12.3
936020019	Red	N/A	1	3	1.4	8	14.3
936020020	Yellow	N/A	1	3	1.4	8	14.3
936020021	Red	N/A	1	3	1.4	10	16.3
936020022	Red	N/A	1	3	1.4	12	18.3
936020023	Yellow	N/A	1	3	1.4	12	18.3
936020024	Black	16	1.5	3.5	1.7	8	14.3
936020025	Red	16	1.5	3.5	1.7	8	14.3
936020026	Black	16	1.5	3.5	1.7	10	16.3
936020027	Red	16	1.5	3.5	1.7	10	16.3
936020028	Black	16	1.5	3.5	1.7	12	18.3
936020029	Black	16	1.5	3.5	1.7	18	24.3
936020030	Red	16	1.5	3.5	1.7	18	24.3

Ferrule	Color	AWG	mm2	Ø	d	P	L
936020031	Blue	14	2.5	4.2	2.3	8	15.4
936020032	Grey	14	2.5	4.2	2.3	8	15.4
936020033	Blue	14	2.5	4.2	2.3	12	19.4
936020034	Grey	14	2.5	4.2	2.3	12	19.4
936020035	Blue	14	2.5	4.2	2.3	18	25.4
936020036	Grey	14	2.5	4.2	2.3	18	25.4
936020037	Orange	12	4	4.8	2.8	10	17.4
936020038	Grey	12	4	4.8	2.8	10	17.4
936020039	Orange	12	4	4.8	2.8	12	19.4
936020040	Grey	12	4	4.8	2.8	12	19.4
936020041	Orange	12	4	4.8	2.8	18	25.4
936020042	Grey	12	4	4.8	2.8	18	25.4
936020043	Black	10	6	6.3	3.5	12	20.5
936020044	Yellow	10	6	6.3	3.5	12	20.5
936020045	Green	10	6	6.3	3.5	12	20.5
936020046	Black	10	6	6.3	3.5	18	26.5
936020047	Yellow	10	6	6.3	3.5	18	26.5
936020048	Green	10	6	6.3	3.5	18	26.5
936020049	Brown	8	10	7.8	4.5	12	20.8
936020050	Red	8	10	7.8	4.5	12	20.8
936020051	White	8	10	7.8	4.5	12	20.8
936020052	Brown	8	10	7.8	4.5	18	26.8
936020053	Red	8	10	7.8	4.5	18	26.8
936020054	White	8	10	7.8	4.5	18	26.8

Wire strip length = P + 2mm

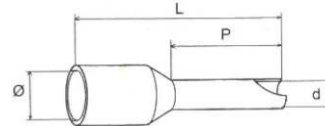

CONDITIONS

After crimping, the ferrule must meet a minimum pull force.

Wire Size		Pull Force Minimum	
AWG	mm ²	N	Lb.
24	0.25	20	4.50
22	0.35	20	4.50
20	0.50	20	4.50
18	0.75	30	6.75
N/A	1.00	35	7.87

Wire Size		Pull Force Minimum	
AWG	mm ²	N	Lb.
16	1.50	40	9.00
14	2.50	50	11.25
12	4.00	60	13.50
10	6.00	80	18.00
8	10.00	90	20.20

INSTALLATION

1. To install the power crimp head on to the battery crimp tool (Order No. 63816-0270 and 63816-0280), refer to the "Setup and Adjustments" section in the manual (Document No. 638160270).
2. To install the power crimp head on to the electric crimping machine (Order No. 63816-1500), refer to the "Mounting the Tool Head or Adapter on the Machine" section in the manual TM-638161500.

MAINTENANCE

It is recommended that each operator of the tool be made aware of and responsible for the following maintenance steps:

1. Remove dust, moisture and other contaminants with a clean brush or a soft, lint-free cloth.
2. Do not use any abrasive materials that could damage the tool.
3. Make certain all pins, pivot points and bearing surfaces in the tool head are protected with a thin coat of high-quality machine oil. Do not oil excessively. This tool was engineered for durability, but like any fine piece of equipment, it needs cleaning and lubrication for a maximum service life of trouble-free crimping. Using a light oil, such as SAE 30 weight automotive oil, every 5,000 cycles or monthly, will significantly enhance the tool life and ensure a stable calibration.
4. Store the tool in a clean and dry area when not in use.

OPERATION

1. Insert a properly-stripped wire into the ferrule connector and cycle the tool through a full cycle to open the jaws of the tool.
2. Place the ferrule connector with the wire onto the jaw of the tool, ensuring that the end of the ferrule does not extend beyond the side face of the jaws. See Figure 1.
 - a. **Warning:** Extending the ferrule connector beyond the face of the jaws will produce parts of the ferrule connector that will not be crimped, potentially resulting in an undesired mate connection.
3. Cycle the tool through a full cycle to complete the crimp.

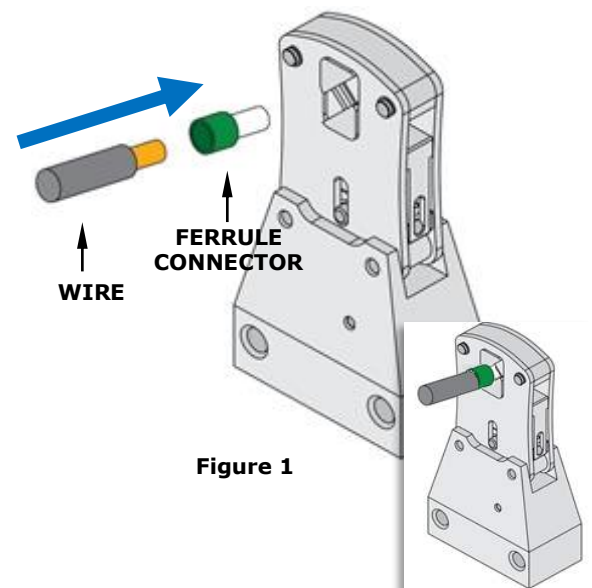

Figure 1

WARRANTY

This tool is for electrical terminal crimping purposes only. This tool is made of the best quality materials. All vital components are long-life tested. All tools are warranted to be free of manufacturing defects for a period of 30 days. Should such a defect occur, Molex will repair or exchange the tool free of charge. This repair or exchange will not be applicable to altered, misused or damaged tools.

CAUTION: Molex specifications are valid only when used with Molex tooling.

PARTS LIST

There are no spare parts for the power crimp head. If any part of the power crimp head malfunctions, the entire head must be replaced.

Item	Order Number	Description
REF	63816-1730	Power Crimp Head

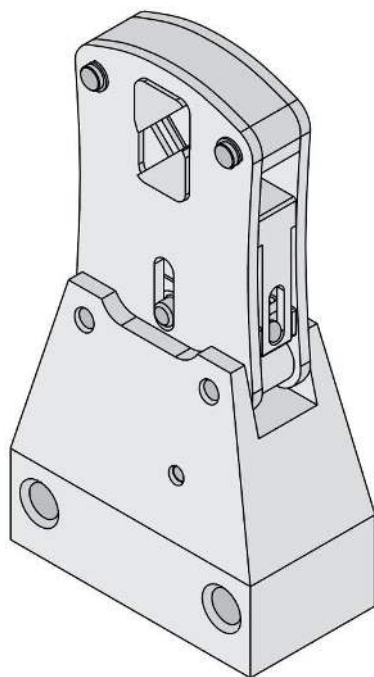

Figure 2

Application Tooling Support

Phone: (402) 458-TOOL (8665)
E-Mail: applicationtooling@molex.com
Website: www.molex.com/applicationtooling

Molex is a registered trademark of Molex, LLC in the United States of America and may be registered in other countries; all other trademarks listed herein belong to their respective owners.