

PART NUMBER	REVISION	DESCRIPTION	FEED TYPE
2151832-1	G	FINE CRIMP HEIGHT ADJUST	MECHANICAL
2151832-2	G	FINE CRIMP HEIGHT ADJUST	PNEUMATIC
3-2151832-2	G	FINE CRIMP HEIGHT ADJUST	DOUBLE ACTING PNEUMATIC WITH SENSORS
7-2151832-1	G	MECHANICAL AND CRIMP TOOLING KIT	MECHANICAL
7-2151832-2	G	PNEUMATIC AND CRIMP TOOLING KIT	PNEUMATIC
7-2151832-7	A	CRIMP TOOLING KIT	-

ATLANTIC VERSION TERMINATOR INTERFACE ADAPTER

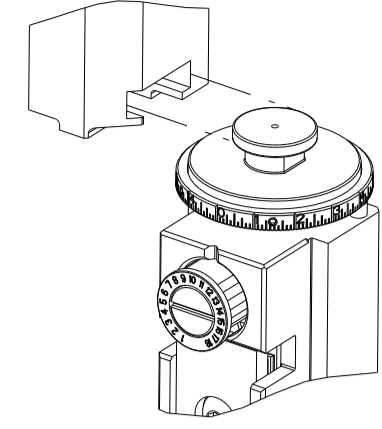

APPLICATOR DATA		
CRIMP	SIZE	TYPE
WIRE	1.12 mm [.044]	F
INSUL	1.57 mm [.062]	0

TERMINAL DATA: TE TERMINAL		TE CRIMP SPECIFICATION	
TERMINAL NAME: CONTACT, MALE, GENERATION Y, 0.64			
WIRE STRIP LENGTH		INSULATION DIAMETER RANGE	
TERMINAL APPLICATION SPECIFICATION	114-13183	-	-

TERMINALS APPLIED			
TE TERMINAL	TE TERMINAL	TE TERMINAL	TE TERMINAL
1924968-8	1-2035334-8	1-1456968-4	1-2138699-4
1-1924727-4	2035170-4	1-1456968-8	1-2138699-8
1924955-8	1-2035170-4	1-1456574-8	1-2098753-4
1-1924955-8	1924275-8	2098762-4	-
2035334-8	1456968-8	1-1456841-8	-

WIRE SIZE	CRIMP HEIGHT mm [INCH]	CRIMP HEIGHT REFERENCE SETTING
2x0.13 OR 2X26 AWG	0.84+/-0.02 [.033+/-0.001]	8.8
0.35mm <sup>2</sup> OR 22 AWG	0.91+/-0.03 [.036+/-0.001]	8.2

- 1 RECOMMENDED SPARE PARTS
- 2 REFER TO SUPPLIED INSTRUCTION SHEET FOR CLEANING, LUBRICATION AND STORAGE OF APPLICATOR.
- 3 APPLY PART NUMBER 2-23419-6 LOCTITE TO THREADS OF ITEM 242.
- 4 CRIMP HEIGHT REFERENCE SETTING WAS THE SETTING USED WHEN THE APPLICATOR WAS QUALIFIED AT THE FACTORY. ADJUSTMENT MAY BE NECESSARY WHEN RUNNING APPLICATOR IN THE FIELD.
- 5. UNLESS SPECIFIED OTHERWISE TORQUE VALUES SHALL BE USED PER DOCUMENT, 101-35000.
- 6 THIS APPLICATOR HAS BEEN DESIGNED TO APPLY WIRES WITH THIN WALL (FLR) INSULATION.
- 7 THIS APPLICATOR EQUIPPED WITH THE DOUBLE ACTING PNEUMATIC FEED WITH SENSORS, AND IS APPLICATION SPECIFIC AND DOES NOT REQUIRE ITEMS 49 & 248.
- 8 WIRE STRIP LENGTH  
2X0.13 mm<sup>2</sup> 2x0.13 mm<sup>2</sup> or 2x 26AWG; 4.3-4.5mm [.169-.177 IN]  
0.35mm<sup>2</sup> or 22AWG; 4.0-4.5 mm [.157-.177 IN]
- 9 INSULATION DIAMETER RANGE  
2X0.13mm<sup>2</sup> or 2X26AWG; 0.85-1.05mm [.033-.041 IN]  
0.35mm<sup>2</sup> or 22AWG; 1.10-1.40mm [.043-.055 IN]

**\*WARNING**  
ON INSTALLATION, SET WIRE DISC TO CRIMP HEIGHT REFERENCE SETTING FOR LARGEST WIRE SIZE. CRIMP HEIGHT REFERENCE SETTINGS GREATER THAN THE VALUE SHOWN MAY CAUSE DAMAGE TO THE CRIMP TOOLING. REFER TO THE INSTRUCTION SHEET FOR PROPER SETUP AND ADJUSTMENTS.

LOC	DIST	REVISIONS			
P	LTN	DESCRIPTION	DATE	OWN	APVD
A	66	E1	ECR-20-016024	11NOV2020	JWC TE
		F	ECR-21-113739	14SEP2021	TB RK
		G	ECR-21-114929	23SEP2021	LG RK
		G1	ECR-21-118441	25OCT2021	FZ RK

-	-	-	1	-	-	2844950-1	AIR FEED MODULE	290
-	1	-	-	1	-	2119641-1	FEED CAM, AIR FEED	248
-	1	1	1	1	1	2119082-8	CAM, SNAIL, INSULATION ADJUSTMENT	244
-	1	1	1	1	1	2079764-1	WASHER, WAVE SPRING, CREST-TO-CREST	243
-	1	1	1	1	1	2119083-1	RETAINER, INSULATION DIAL	242
-	1	1	1	1	1	7-18023-7	SCR, SKT HD CAP M3 X 4.0	241
-	-	1	-	-	1	2119580-1	MECHANICAL FEED ASSEMBLY	239
-	1	-	-	1	-	2844940-1	AIR FEED MODULE	238
-	REF	REF	REF	REF	REF	994970-2	COUNTER, MAGNETIC	164
-	1	1	1	1	1	2844908-1	SCREW, LOCKING	99
-	1	1	1	1	1	2844907-1	POST, LOCKING	98
-	1	1	1	1	1	455888-4	SPACER, CRIMPER	82
-	1	1	1	1	1	1803607-3	DOCUMENTATION PACKAGE	71
-	1	1	1	1	1	2119791-9	DEPRESSOR, WIRE	70
-	1	1	1	1	1	2119740-1	TAG, IDENTIFICATION	67
-	2	2	2	2	2	2168078-1	SCREW, DRIVE, RH, RoHS, 2 x .188	66
-	1	1	1	1	1	2168083-2	SCR, SKT HD CAP, RoHS, M4 X 8.0	60
-	1	1	1	1	1	5-18022-5	SCR, HEX HD CAP, M4 X 6.0	59
-	1	1	1	1	1	1338685-1	PAWL, FEED	56
-	4	4	4	4	4	2168083-3	SCR, SKT HD CAP, RoHS, M4 X 12.0	54
-	2	2	2	2	2	1-2168083-0	SCR, SKT HD CAP, RoHS, M4 X 10	53
-	1	1	1	1	1	1803382-6	HOLD DOWN, SPRING LOADED	50
-	1	2	-	1	2	18023-9	SCR, SKT HD CAP M4 X 6.0	49
-	-	1	-	-	1	2119652-1	FEED CAM, PRE FEED	48
-	-	1	-	-	1	2119653-1	FEED CAM, POST FEED	47
-	1	1	1	1	1	1803583-9	APPLICATOR BASIC ASSEMBLY, SF	46
-	1	1	1	1	1	1803515-1	RAM ASSEMBLY, SF ATLANTIC	44
-	1	1	1	1	1	1803602-1	SCR, BHSC, RoHS (M8 X 25)	41
-	1	1	1	1	1	1752356-1	SUPPORT, TERMINAL	34
-	2	2	2	2	2	2079383-5	SCR, BHSC, RoHS (M4 X 20)	33
-	2	2	2	2	2	2-2844962-4	SPACER, CYLINDRICAL, STRIP GUIDE	30
-	1	1	1	1	1	2844992-7	ASSEMBLY, STRIP GUIDE	29
-	1	1	1	1	1	1320928-2	STRIP GUIDE	24
-	1	1	1	1	1	2168083-2	SCR, SKT HD CAP, RoHS, M4 X 8.0	21
-	2	2	2	2	2	1-18028-2	WASHER, FLAT, REG M4	20
-	1	1	1	1	1	2119533-1	STRIPPER, SIDE FEED	19
-	1	1	1	1	1	2119806-1	INSERT, SHEAR	13
-	1	1	1	1	1	3-22280-3	SPRING, COMPRESSION	12
-	1	1	1	1	1	1-356885-4	STOP, SHEAR	11
-	1	1	1	1	1	2119805-1	SHEAR HOLDER, FRONT	10
-	1	1	1	1	1	1803095-1	FLOATING SHEAR, FRONT	9
-	1	2	2	1	1	1803058-6	ANVIL, COMBINATION	8
-	-	-	-	-	-	-	-	7
-	-	-	-	-	-	-	-	6
-	1	1	1	1	1	2119757-1	DEPRESSOR, SHEAR	5
-	1	1	1	1	1	3-238011-1	BLOCK, CRIMPER SPACER	4
-	1	2	2	1	1	1-1803019-1	CRIMPER, INSULATION 0	3
-	1	1	1	1	1	455888-1	SPACER, CRIMPER	2
-	1	2	2	1	1	3-1633860-6	CRIMPER, WIRE	1

ATLANTIC VERSION  
Shown on sheets 1 of 4 & 2 of 4  
(Pacific version shown on sheets 3 of 4 & 4 of 4)

DIMENSIONS:		TOLERANCES UNLESS OTHERWISE SPECIFIED:		MATERIAL:	
mm	0 PLC ±	1 PLC ±	2 PLC ±	3 PLC ±	4 PLC ±
	ANGLES ±	FINISH ±			

OWN	H. HUANG	26APR2010
CHK	L. ZHANG	26APR2010
APVD	J. GUO	26APR2010
PRODUCT SPEC		
APPLICATION SPEC		
SIZE	A1	00779
CAGE CODE		
DRAWING NO		2151832
RESTRICTED TO		
Customer Accessible Production Drawing	SCALE	1:2
SHEET	1	OF 4
REV		G1

LOC	DIST	REVISIONS					
A	66	P	LTN	DESCRIPTION	DATE	DWN	APVD
		-		SEE SHEET 1			

# FEED TYPE MECHANICAL

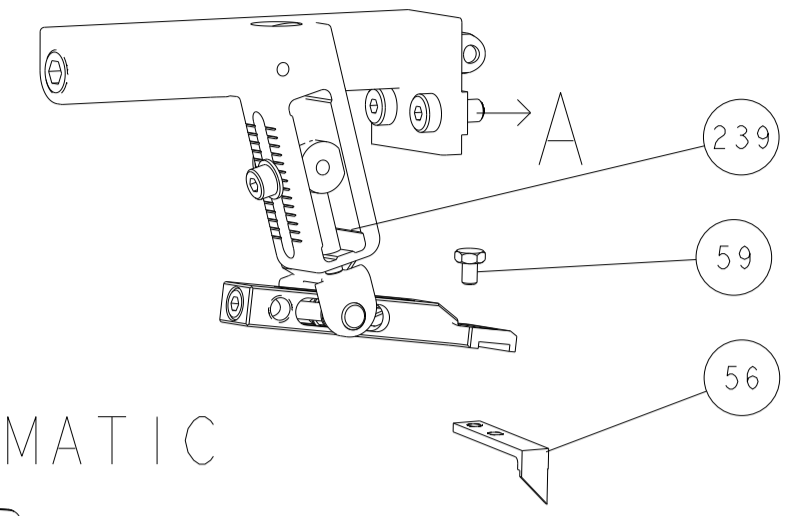

## PNEUMATIC

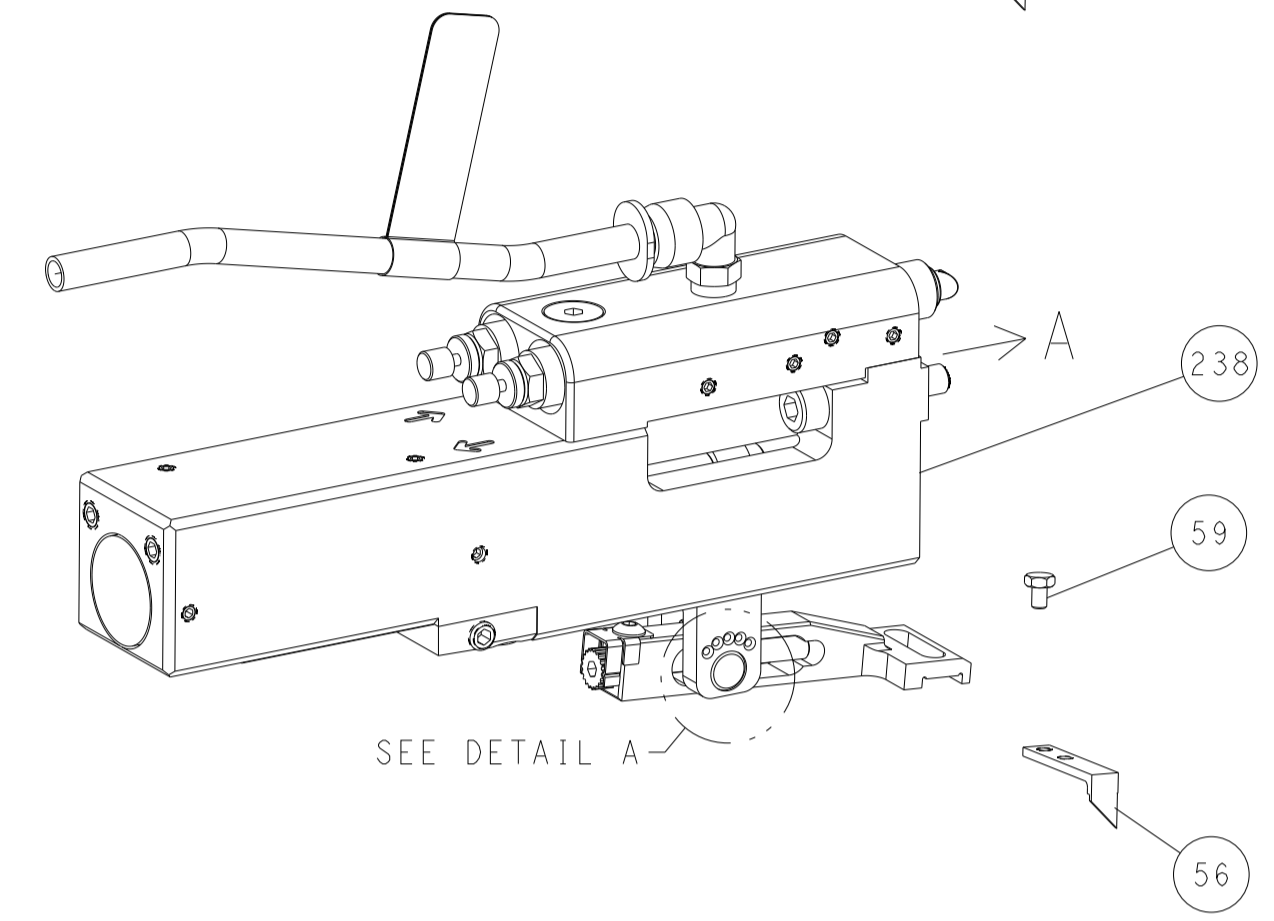

## FEED SPRING SETTING POSITION (SHOWN FROM REAR SIDE)

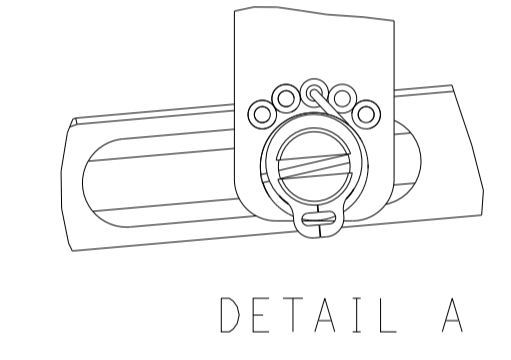

## DOUBLE ACTING PNEUMATIC WITH SENSORS

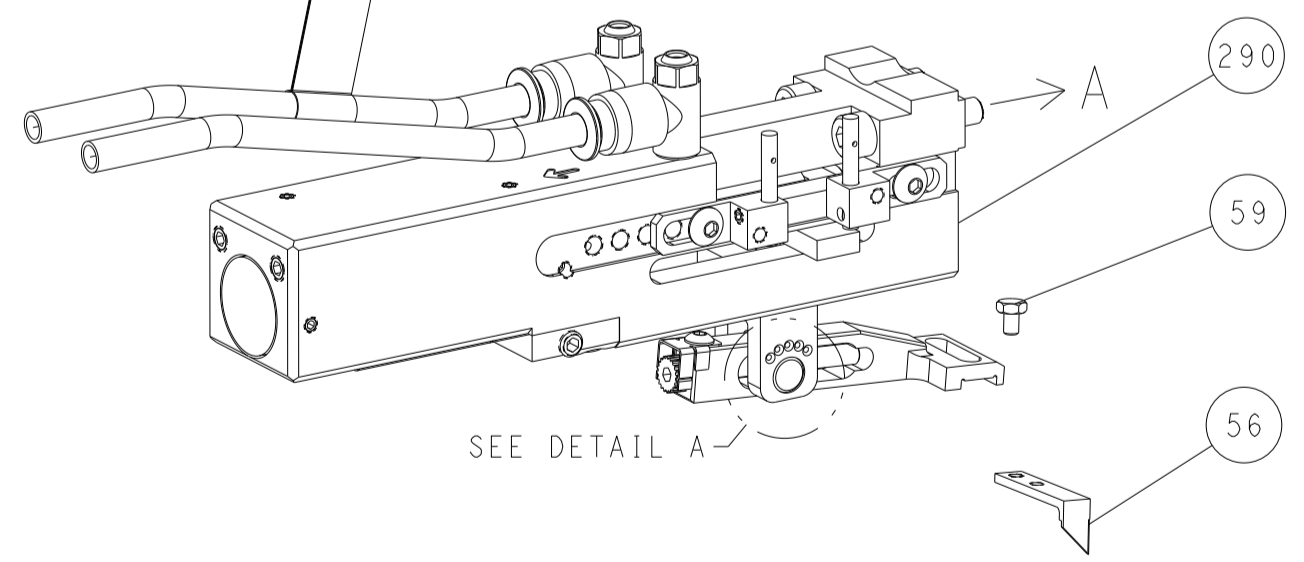

## CAM POSITIONS

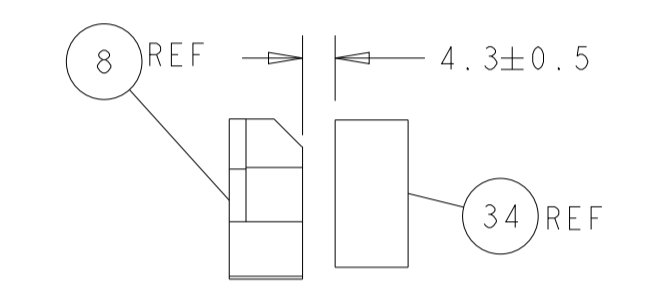
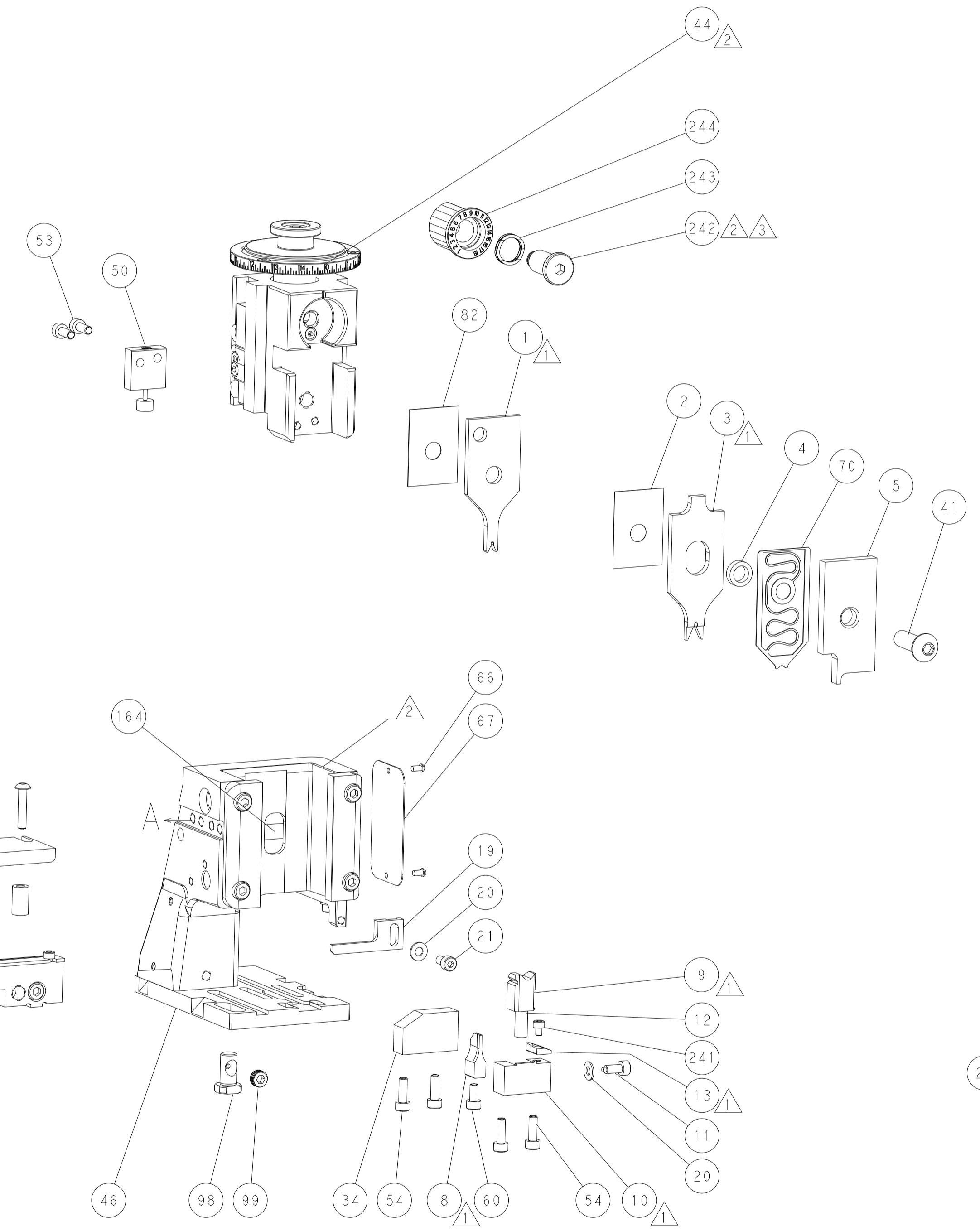
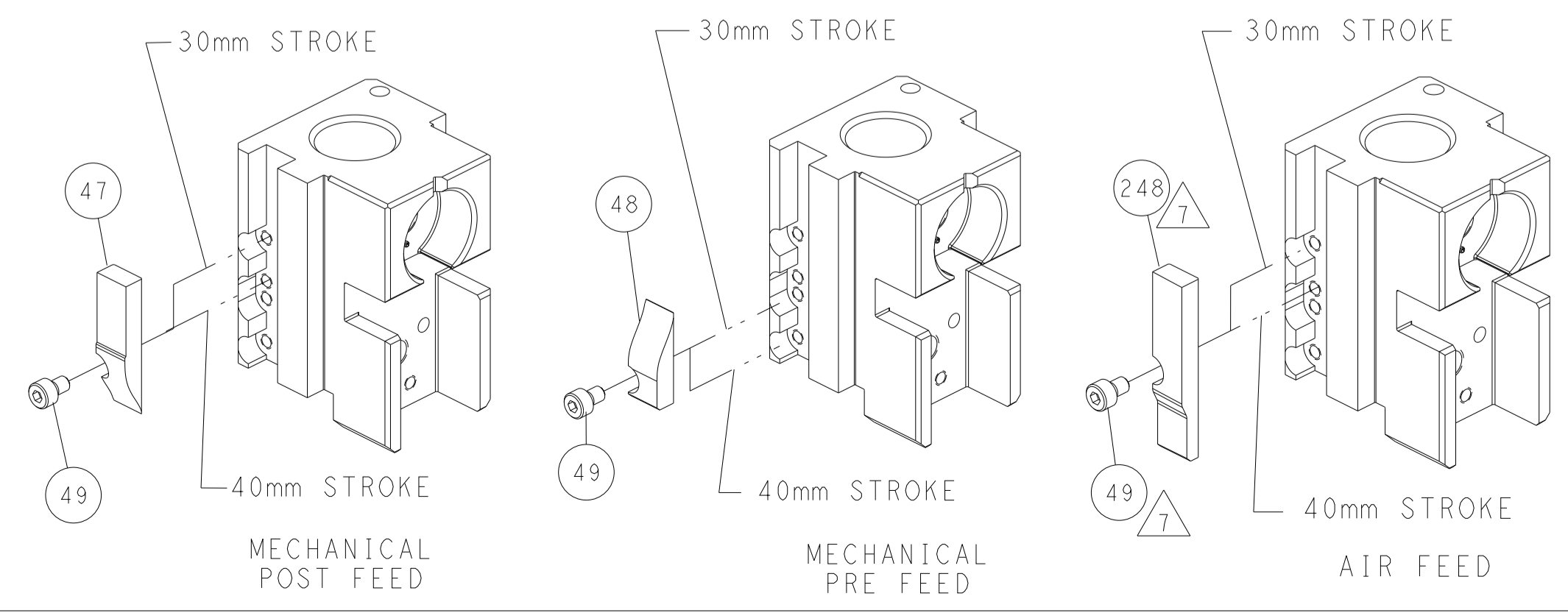

TERMINAL SUPPORT LOCATION

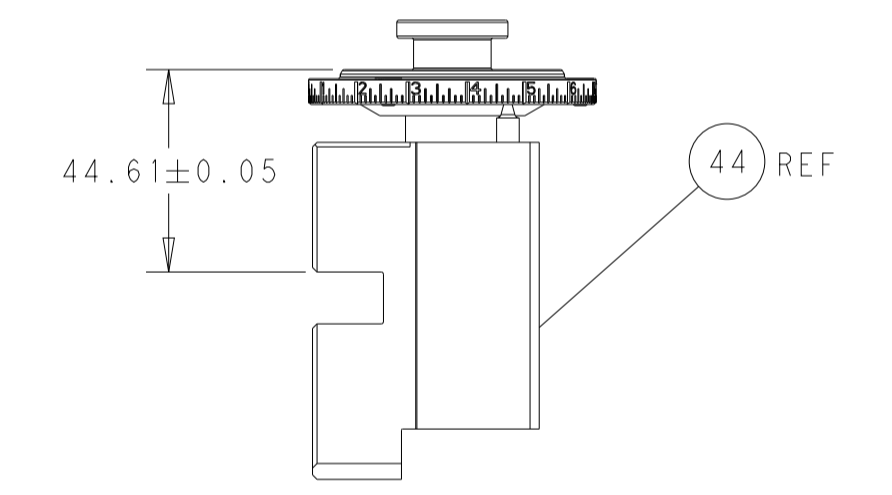

RAM SET-UP

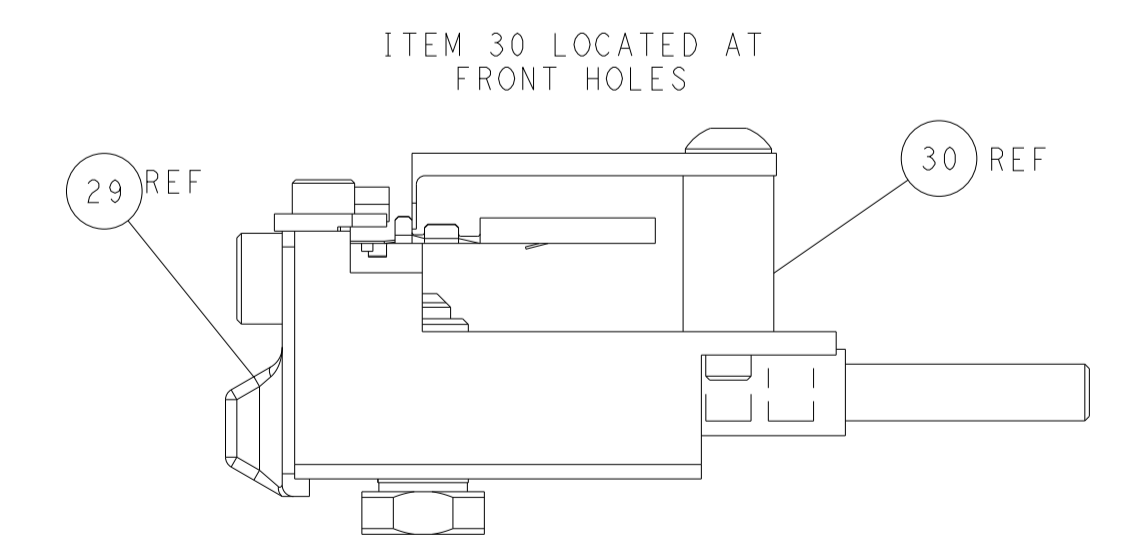

FEED TRACK POSITION GUIDE BY INSULATION BARREL

**ATLANTIC VERSION**  
 Shown on sheets 1 of 4 & 2 of 4  
 (Pacific version shown on sheets 3 of 4 & 4 of 4)

DIMENSIONS:		TOLERANCES UNLESS OTHERWISE SPECIFIED:		DRAWING NO		SCALE	
mm	0 PLC ±	1 PLC ±	2 PLC ±	3 PLC ±	4 PLC ±	ANGLES ±	FINISH ±
MATERIAL							
Customer Accessible Production Drawing				SCALE	1:2	SHEET	2 OF 4

DWN	R. HUANG	26APR2010	TE Connectivity Harrisburg, PA 17105-3608					
CHK	L. ZHANG	26APR2010						
APVD	J. GUO	26APR2010						
NAME	Ocean Side Feed Applicator							
PRODUCT SPEC	SIZE	CAGE CODE	DRAWING NO	RESTRICTED TO				
APPLICATION SPEC	A1	00779	©=2151832					
WEIGHT	Customer Accessible Production Drawing		SCALE	1:2	SHEET	2 OF 4	REV	G1

PART NUMBER	REVISION	DESCRIPTION	FEED TYPE
2-2151832-1	G	FINE CRIMP HEIGHT ADJUST	MECHANICAL
2-2151832-2	G	FINE CRIMP HEIGHT ADJUST	PNEUMATIC
4-2151832-2	G	FINE CRIMP HEIGHT ADJUST	DOUBLE ACTING PNEUMATIC WITH SENSORS
7-2151832-7	A	CRIMP TOOLING KIT	-

PACIFIC VERSION TERMINATOR INTERFACE ADAPTER



APPLICATOR DATA

CRIMP	SIZE	TYPE
WIRE	1.12 mm [.044]	F
INSUL	1.57 mm [.062]	O

APPLICATOR INSTRUCTIONS  
408-35042

TERMINAL DATA: TE TERMINAL TE CRIMP SPECIFICATION  
 TERMINAL NAME: CONTACT, MALE, GENERATION Y, 0.64

WIRE STRIP LENGTH	INSULATION DIAMETER RANGE
114-13183	

TERMINAL APPLICATION SPECIFICATION

TERMINALS APPLIED

TE TERMINAL	TE TERMINAL	TE TERMINAL	TE TERMINAL
1924968-8	1-2035334-8	1-1456968-4	1-2138699-4
1-1924727-4	2035170-4	1-1456968-8	1-2138699-8
1924955-8	1-2035170-4	1-1456574-8	1-2098753-4
1-1924955-8	1924275-8	2098762-4	
2035334-8	1456968-8	1-1456841-8	

WIRE SIZE	CRIMP HEIGHT mm [INCH]	CRIMP HEIGHT REFERENCE SETTING
2x0.13 OR 2X26 AWG	0.84 +/- 0.02 [0.033 +/- .001]	8.8
0.35mm <sup>2</sup> OR 22 AWG	0.91 +/- 0.03 [0.036 +/- .001]	8.2

- RECOMMENDED SPARE PARTS
- REFER TO SUPPLIED INSTRUCTION SHEET FOR CLEANING, LUBRICATION AND STORAGE OF APPLICATOR.
- APPLY PART NUMBER 2-23419-6 LOCTITE TO THREADS OF ITEM 242.
- CRIMP HEIGHT REFERENCE SETTING WAS THE SETTING USED WHEN THE APPLICATOR WAS QUALIFIED AT THE FACTORY. ADJUSTMENT MAY BE NECESSARY WHEN RUNNING APPLICATOR IN THE FIELD.
- UNLESS SPECIFIED OTHERWISE TORQUE VALUES SHALL BE USED PER DOCUMENT, 101-35000.
- THIS APPLICATOR HAS BEEN DESIGNED TO APPLY WIRES WITH THIN WALL (FLR) INSULATION.
- THIS APPLICATOR EQUIPPED WITH THE DOUBLE ACTING PNEUMATIC FEED WITH SENSORS, AND IS APPLICATION SPECIFIC AND DOES NOT REQUIRE ITEMS 49 & 151.
- WIRE STRIP LENGTH  
2X0.13 mm<sup>2</sup> 2x0.13 mm<sup>2</sup> or 2x 26AWG; 4.3-4.5mm [.169-.177 IN]  
0.35mm<sup>2</sup> or 22AWG; 4.0-4.5 mm [.157-.177 IN]
- INSULATION DIAMETER RANGE  
2X0.13mm<sup>2</sup> or 2X26AWG; 0.85-1.05mm [.033-.041 IN]  
0.35mm<sup>2</sup> or 22AWG; 1.10-1.40mm [.043-.055 IN]

**\*WARNING**  
 ON INSTALLATION, SET WIRE DISC TO CRIMP HEIGHT REFERENCE SETTING FOR LARGEST WIRE SIZE. CRIMP HEIGHT REFERENCE SETTINGS GREATER THAN THE VALUE SHOWN MAY CAUSE DAMAGE TO THE CRIMP TOOLING. REFER TO THE INSTRUCTION SHEET FOR PROPER SETUP AND ADJUSTMENTS.

LOC	DIST	REV	LTN	DESCRIPTION	DATE	OWN	APVD
A	66	-	-	SEE SHEET 1	-	-	-

-	1	-	-	2844950-1	AIR FEED MODULE		290
-	1	1	1	2119082-8	CAM, SNAIL, INSULATION ADJUSTMENT		244
-	1	1	1	2079764-1	WASHER, WAVE SPRING, CREST-TO-CREST		243
-	1	1	1	2119083-1	RETAINER, INSULATION DIAL		242
-	1	1	1	7-18023-7	SCR, SKT HD CAP M3 X 4.0		241
-	-	-	1	2119580-1	MECHANICAL FEED ASSEMBLY		239
-	-	1	-	2844940-1	AIR FEED MODULE		238
-	REF	REF	REF	994970-2	COUNTER, MAGNETIC		164
-	-	1	-	2119641-2	FEED CAM, AIR FEED		151
-	1	1	1	2168083-8	SCR, SKT HD CAP, RoHS, M4 X 16		144
-	4	4	4	2168083-9	SCR, SKT HD CAP, RoHS, M4 X 20		143
-	-	-	1	2119653-2	FEED CAM, POST FEED		142
-	1	1	1	1-1803583-0	APPLICATOR BASIC ASSEMBLY, SF		141
-	1	1	1	1803516-1	RAM ASSEMBLY, SF PACIFIC		140
-	1	1	1	2844908-1	SCREW, LOCKING		99
-	1	1	1	2844907-1	POST, LOCKING		98
-	1	1	1	455888-4	SPACER, CRIMPER		82
-	1	1	1	1803607-3	DOCUMENTATION PACKAGE		71
-	1	1	1	2119791-9	DEPRESSOR, WIRE		70
-	1	1	1	2119740-1	TAG IDENTIFICATION		67
-	2	2	2	2168078-1	SCREW, DRIVE, RH, RoHS, 2 x .188		66
-	1	1	1	5-18022-5	SCR, HEX HD CAP, M4 X 6.0		59
-	1	1	1	1338685-1	PAWL, FEED		56
-	2	2	2	1-2168083-0	SCR, SKT HD CAP, RoHS, M4 X 10		53
-	1	1	1	1803382-6	HOLD DOWN, SPRING LOADED		50
-	-	1	2	18023-9	SCR, SKT HD CAP M4 X 6.0		49
-	-	-	1	2119652-1	FEED CAM, PRE FEED		48
-	1	1	1	1803602-1	SCR, BHSC, RoHS (M8 X 25)		41
-	1	1	1	1752356-1	SUPPORT, TERMINAL		34
-	2	2	2	2079383-5	SCR, BHSC, RoHS (M4 X 20)		33
-	2	2	2	2-2844962-4	SPACER, CYLINDRICAL, STRIP GUIDE		30
-	1	1	1	2844992-7	ASSEMBLY, STRIP GUIDE		29
-	1	1	1	1320928-2	STRIP GUIDE		24
-	1	1	1	2168083-2	SCR, SKT HD CAP, RoHS, M4 X 8.0		21
-	2	2	2	1-18028-2	WASHER, FLAT, REG M4		20
-	1	1	1	2119533-1	STRIPPER, SIDE FEED		19
-	1	1	1	2119806-1	INSERT, SHEAR		13
-	1	1	1	3-22280-3	SPRING, COMPRESSION		12
-	1	1	1	1-356885-4	STOP, SHEAR		11
-	1	1	1	2119805-1	SHEAR HOLDER, FRONT		10
-	1	1	1	1803095-1	FLOATING SHEAR, FRONT		9
-	1	1	1	1803058-6	ANVIL, COMBINATION		8
-	-	-	-	-	-		7
-	-	-	-	-	-		6
-	1	1	1	2119757-1	DEPRESSOR, SHEAR		5
-	1	1	1	3-238011-1	BLOCK, CRIMPER SPACER		4
-	1	1	1	1-1803019-1	CRIMPER, INSULATION O		3
-	1	1	1	455888-1	SPACER, CRIMPER		2
-	1	1	1	3-1633860-6	CRIMPER, WIRE		1

DIMENSIONS:		TOLERANCES UNLESS OTHERWISE SPECIFIED:		MATERIAL:		FINISH:		WEIGHT:		SCALE:		SHEET:		REV:	
mm	0 PLC ±	1 PLC ±	2 PLC ±	3 PLC ±	4 PLC ±	ANGLES	FINISH			A1	00779	3	4	G1	

PACIFIC VERSION  
 Shown on sheets 3 of 4 & 4 of 4  
 (Atlantic version shown on sheets 1 of 4 & 2 of 4)

LOC		DIST		REVISIONS			
A	66	P	LTM	DESCRIPTION	DATE	OWN	APVD
		-		SEE SHEET 1			

# FEED TYPE MECHANICAL

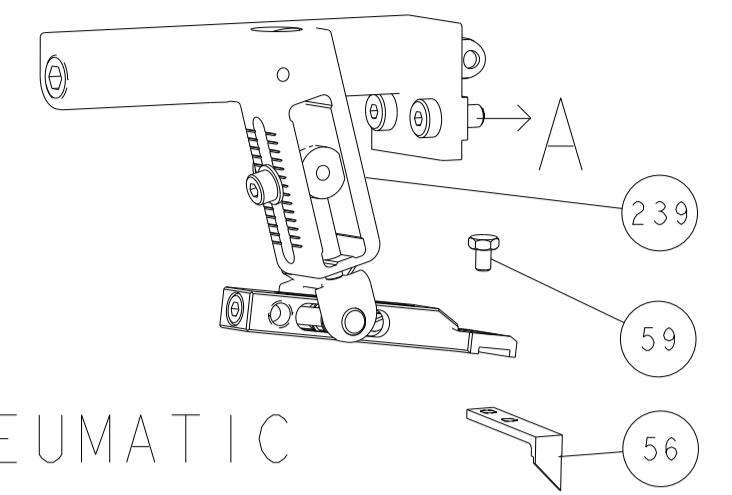

## PNEUMATIC

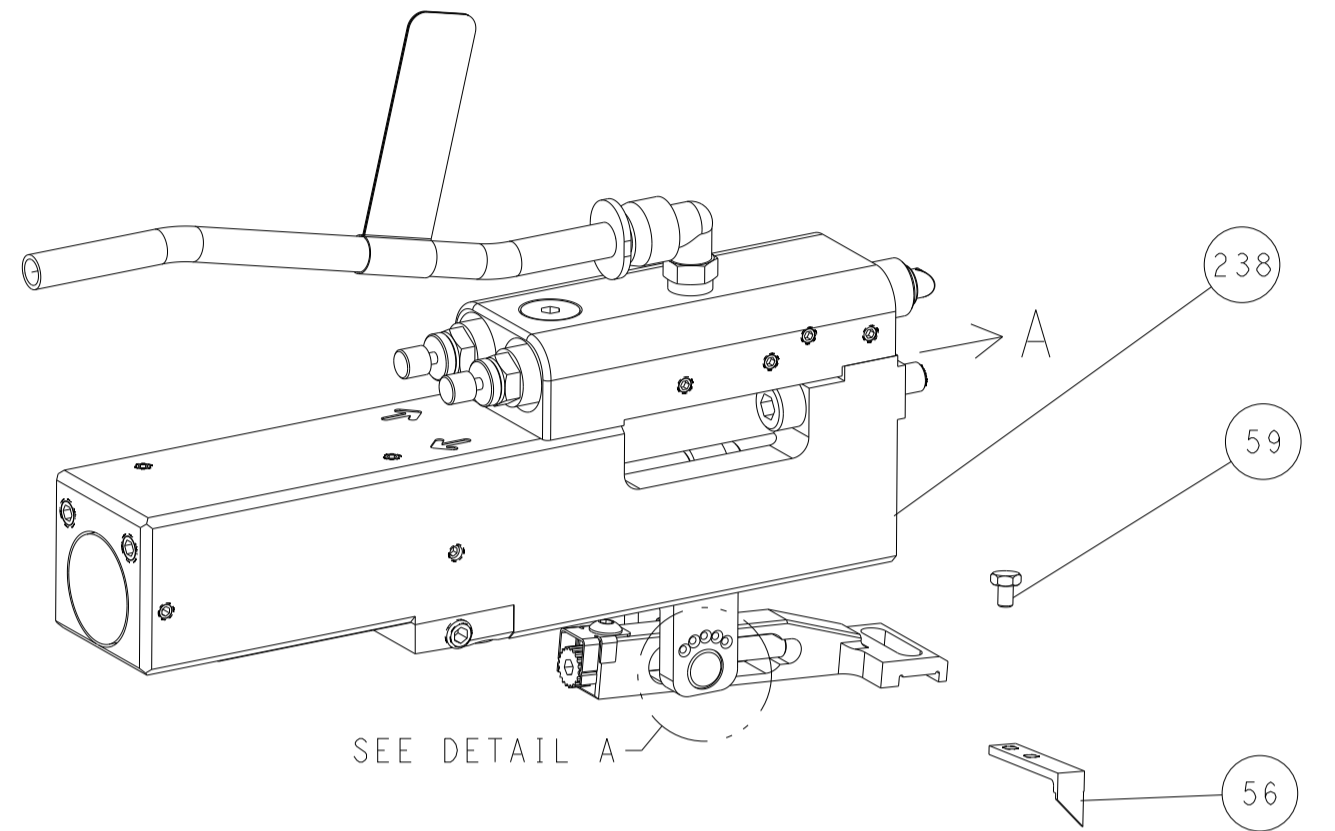

## FEED SPRING SETTING POSITION (SHOWN FROM REAR SIDE)

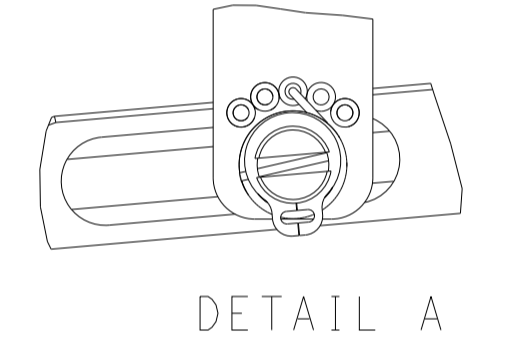

## DOUBLE ACTING PNEUMATIC WITH SENSORS

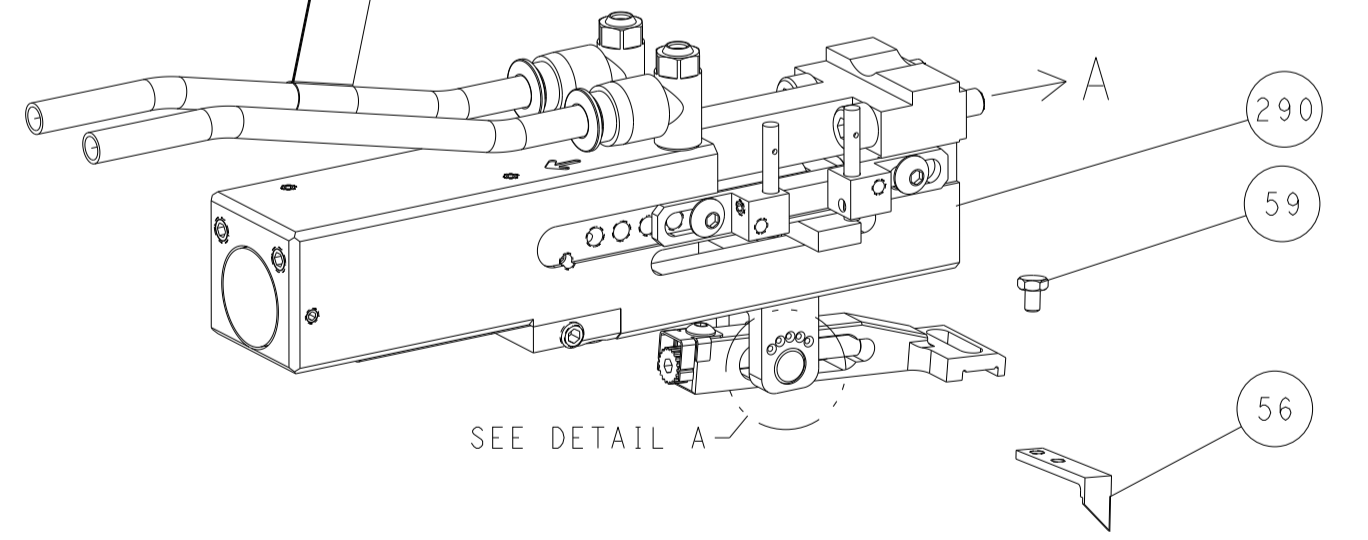

## CAM POSITIONS

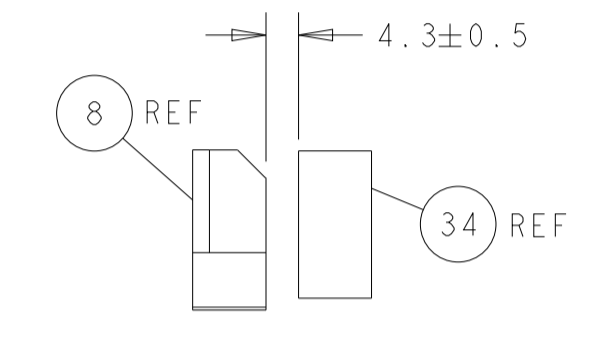
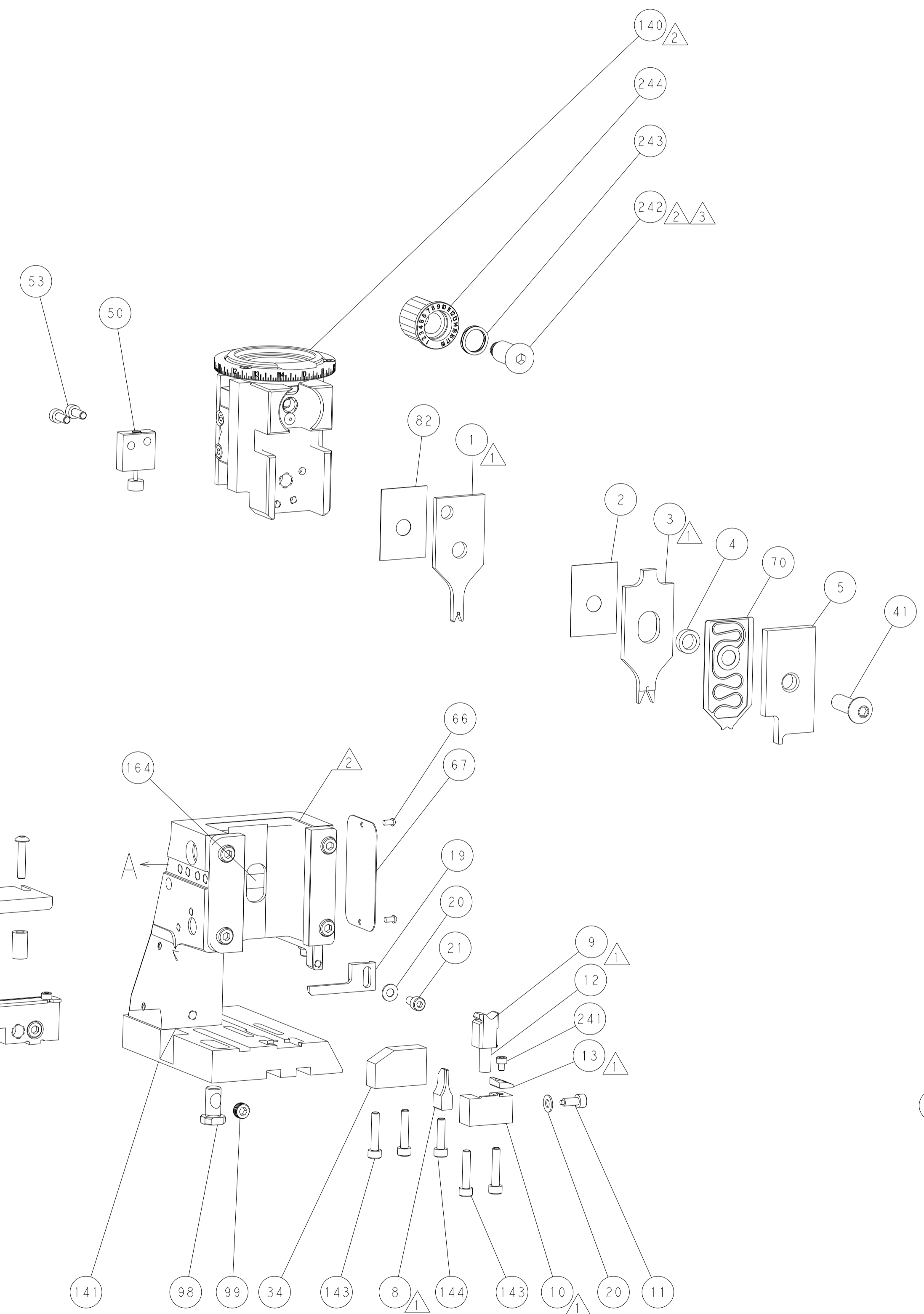
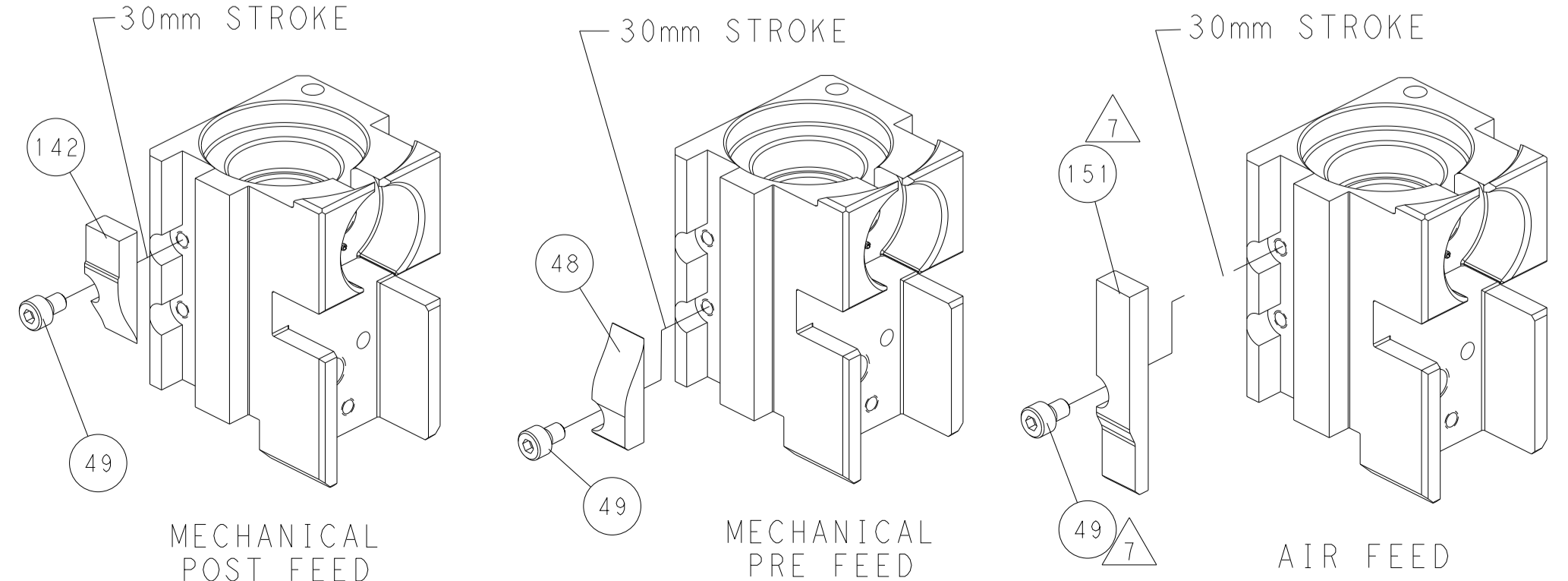

TERMINAL SUPPORT LOCATION

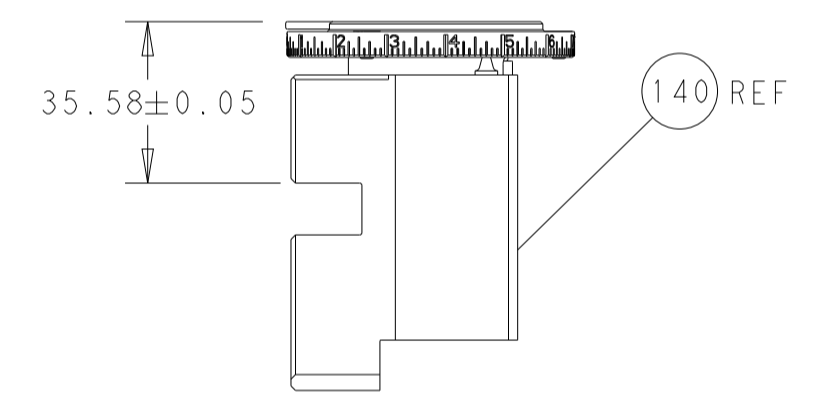

RAM SET-UP

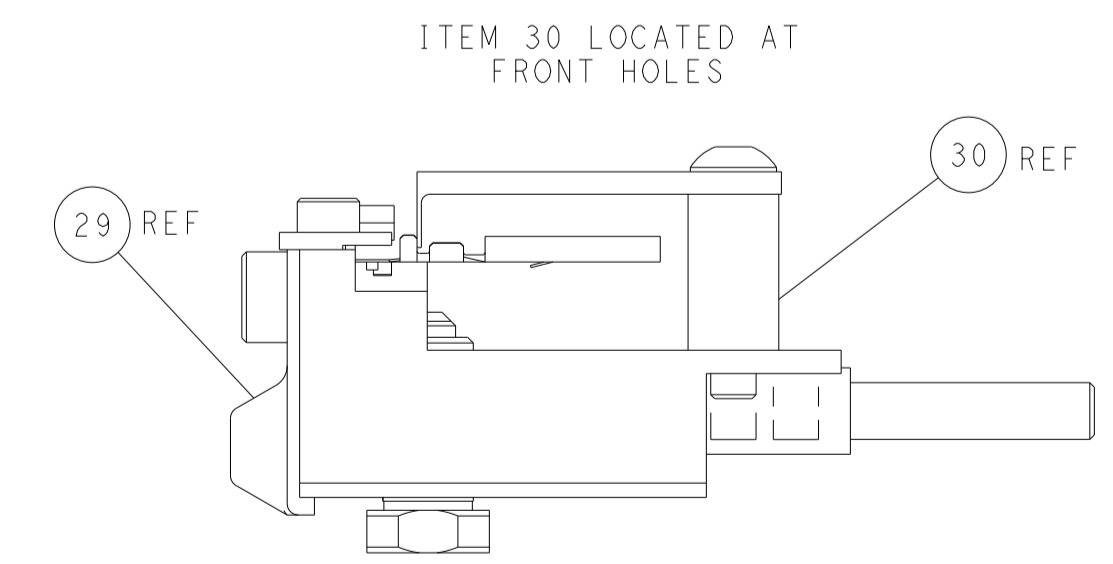

FEED TRACK POSITION GUIDE BY INSULATION BARREL

**PACIFIC VERSION**  
 Shown on sheets 3 of 4 & 4 of 4  
 (Atlantic version shown on sheets 1 of 4 & 2 of 4)

<small>THIS DRAWING IS UNPUBLISHED. RELEASED FOR PUBLICATION BY TYCO ELECTRONICS CORPORATION. ALL RIGHTS RESERVED.</small>		DWN: H. HUANG 26APR2010 CHK: L. ZHANG 26APR2010 APVD: J. GUO 26APR2010	TE Connectivity Harrisburg, PA 17105-3608
DIMENSIONS: mm TOLERANCES UNLESS OTHERWISE SPECIFIED: 0 PLC ± 1 PLC ± 2 PLC ± 3 PLC ± 4 PLC ± ANGLES FINISH ±		NAME: Ocean Side Feed Applicator PRODUCT SPEC: APPLICATION SPEC: WEIGHT:	SIZE: A1 CAGE CODE: 00779 DRAWING NO: C-2151832 SCALE: 1:2 SHEET: 4 of 4 REV: G1
MATERIAL:		Customer Accessible Production Drawing	