

LOC	DIST	REV	DATE	BY	CHK	APPV
CM	00	N1	16MAY2011	RK	HMR	

- △ MATERIAL: NYLON UL94V-2 (NATURAL).
- 2. RECOMMENDED PANEL THICKNESS 2.29 [.090] MAX.
- 3. MARKING FOR UL AND CSA LOGO SHALL BE LOCATED ON ANY EXTERNAL SURFACE.
- △ AMP LOGO AND CIRCUIT NUMBERS LOCATED IN AREA, EITHER SIDE, SIZE OPTIONAL, FROST BACKGROUND.
- △ WALL THICKNESS TO MEASURE 0.36-0.51 [.014-.020].

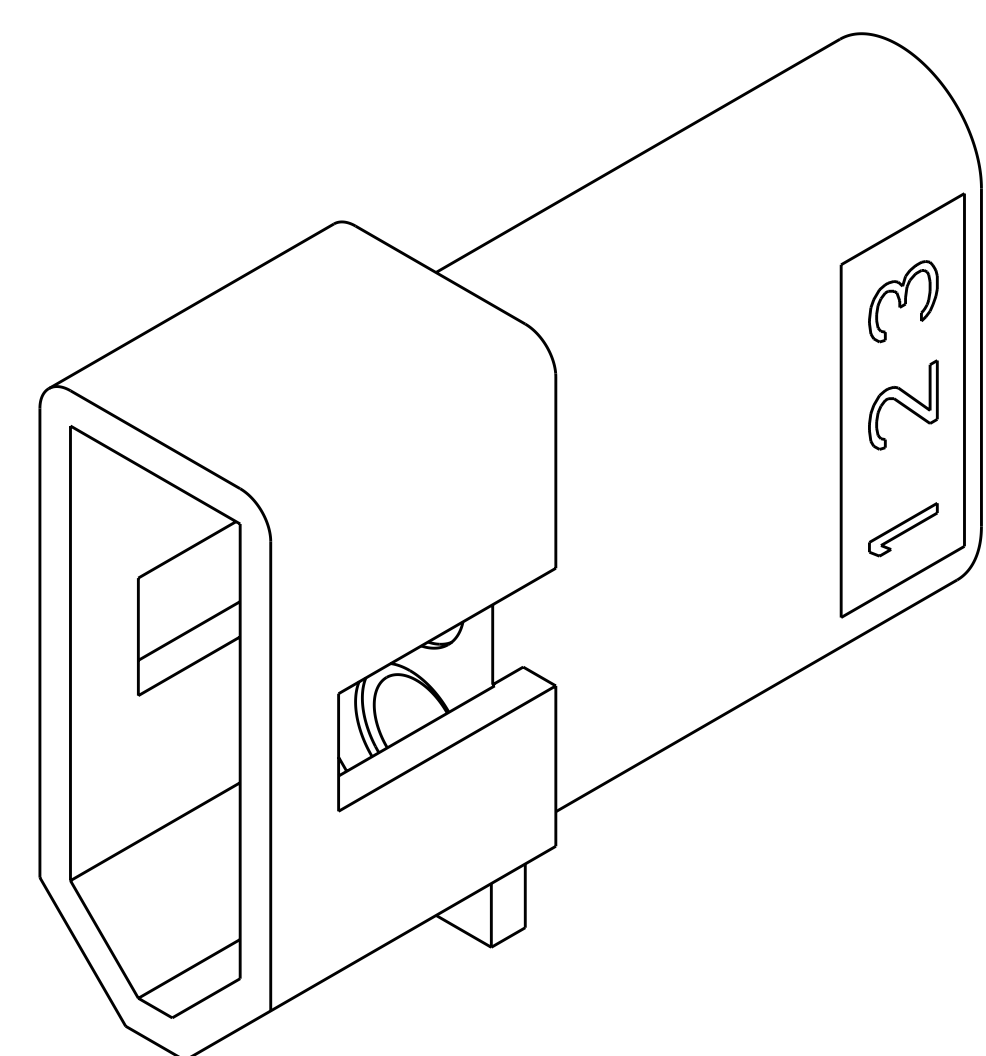
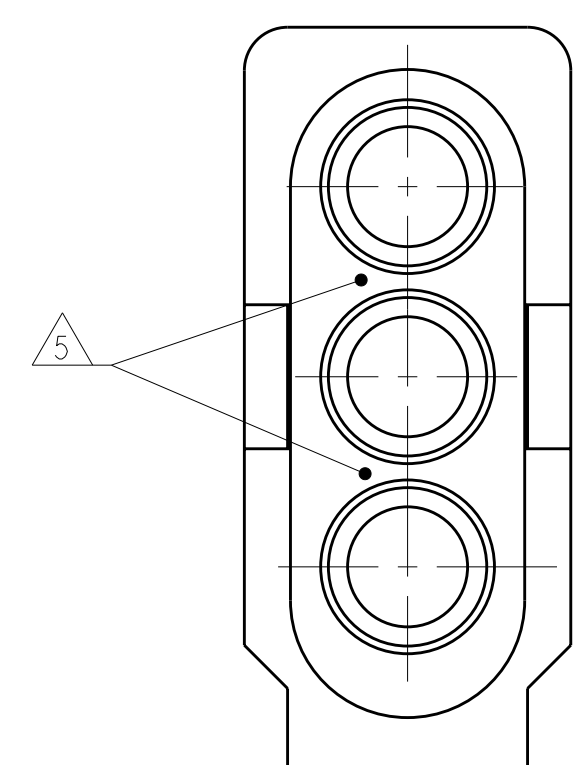
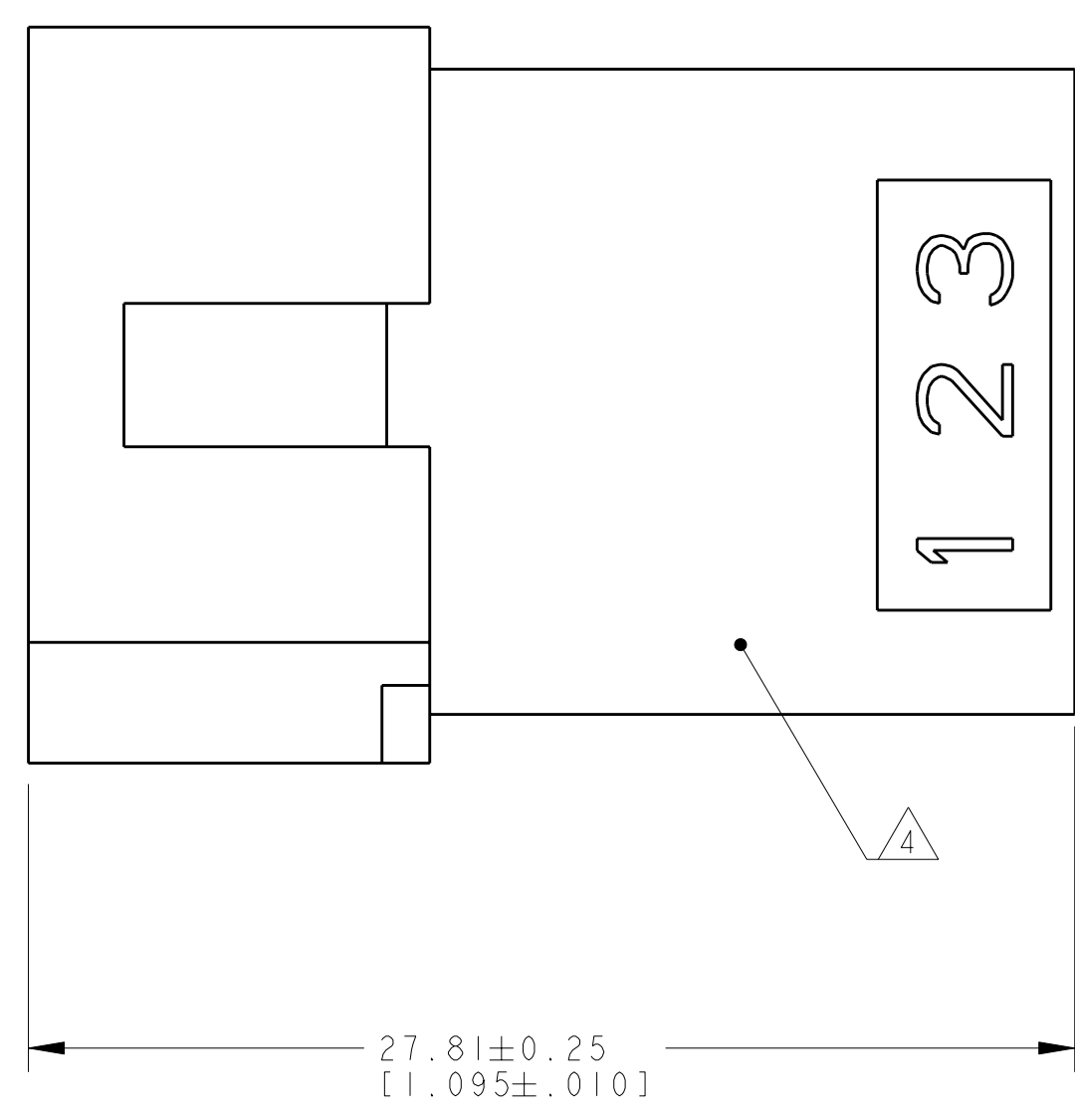
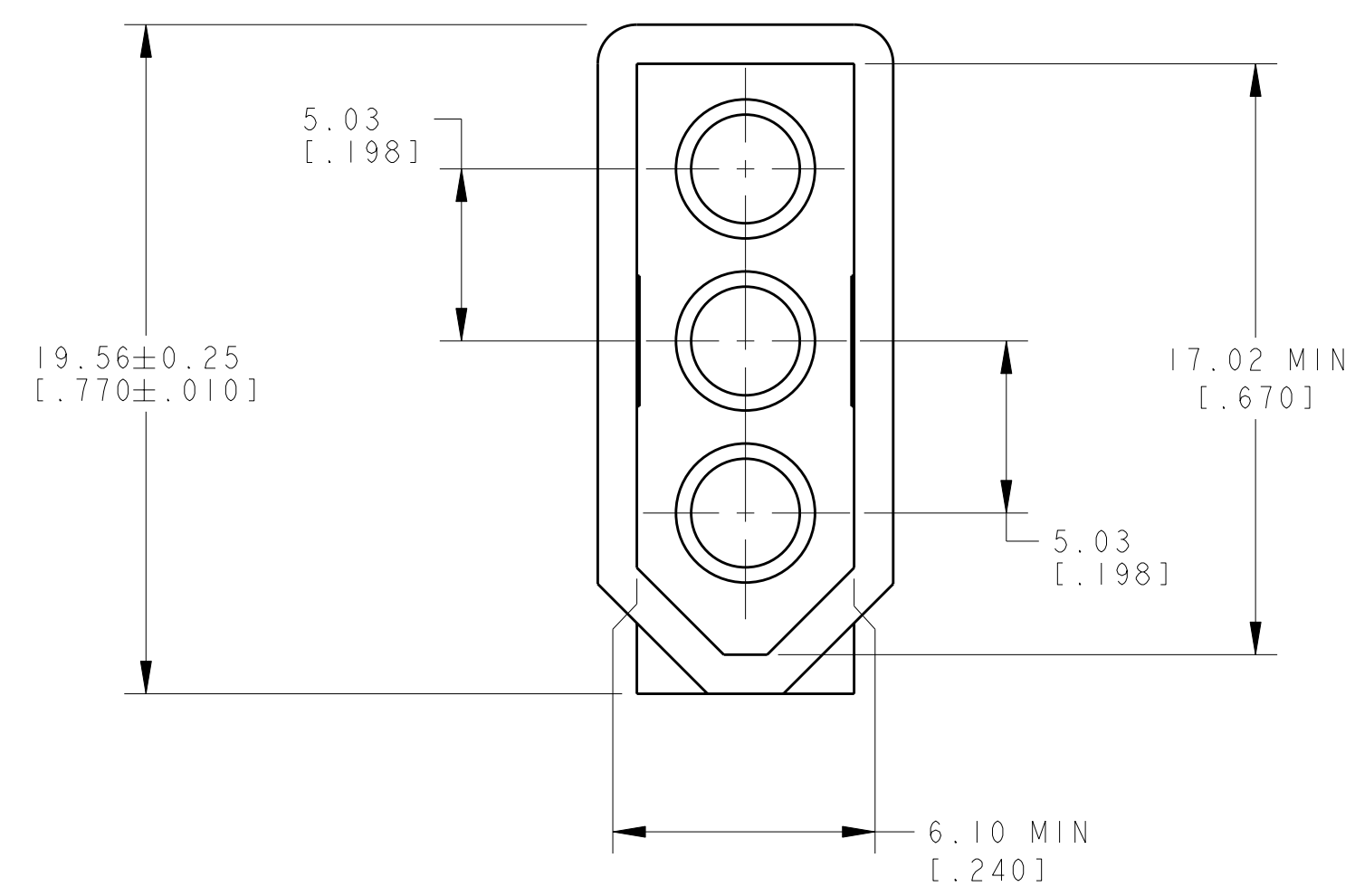

METRIC

770074-1
PART NUMBER

THIS DRAWING IS A CONTROLLED DOCUMENT.		DWN R. WHITAKER 05AUG2004	TE Connectivity
DIMENSIONS: mm [INCHES]		CHK D. COLEY 05AUG2004	
TOLERANCES UNLESS OTHERWISE SPECIFIED:		APVD D. COLEY 05AUG2004	NAME PLUG, 3 CIRCUIT, .093 COMMERCIAL PIN AND SOCKET
0 PLC ±	1 PLC ±	PRODUCT SPEC	SIZE CAGE CODE DRAWING NO
2 PLC ±	3 PLC ±0.13 (1.005)	APPLICATION SPEC	A100779C=770074
4 PLC ±	ANGLES ±	WEIGHT	RESTRICTED TO
FINISH	±0°30'	CUSTOMER DRAWING	SCALE 5:1 SHEET 1 OF 1 REV. N1