

DO NOT SCALE FROM THIS PRINT

NOTES:

- ① REPRESENTS A CRITICAL DIMENSION.
- PARTS SHALL BE ROHS COMPLIANT.
- PARTS TO BE PACKAGED IN TRAYS, TAIL SIDE DOWN. (LESS THAN FULL TRAY QUANTITIES ARE TO BE PACKAGED IN COVERED TRAYS TRIMMED TO MATCH QUANTITY ORDERED)
- HDMR FORMERLY NAMED HDMI.
- DIMENSION APPLIES TO CONTACT & SHIELD.
- ORDERS WILL BE PACKAGED ACCORDING TO THE SAMTEC PACKAGING EFFICIENCY STANDARDS (SPES) FOUND ON WWW.SAMTEC.COM.
- ATTACH LABEL TO EACH REEL.

DESIGNED & DIMENSIONED IN MILLIMETERS [INCHES]

(SEE NOTE 4)

HDMR-XX-XX-X-XX-XX-XX

No OF POSITIONS

- 19: (SEE SHT 1, FIG. 1)
- 29: (SEE SHT 4)

SHIELD TAIL STYLE

- 01: THROUGH HOLE
- 02: SURFACE MOUNT (SEE SHT 3, FIG 2)(-19 POS ONLY)

③ PLATING

- (-19 POSITION)
- S: CONTACT AREA: .000030" GOLD TAILS: BRIGHT ACID TIN SHELL: NICKEL
- F: CONTACT AREA: .000001" GOLD TAILS: BRIGHT ACID TIN SHELL: NICKEL
- (-29 POSITION)
- S: CONTACT AREA: .000030" GOLD TAILS: BRIGHT ACID TIN SHELL: NICKEL
- F: CONTACT AREA: .000001" GOLD TAILS: BRIGHT ACID TIN SHELL: NICKEL

PACKAGING

- BLANK: TRAY (SEE NOTES 3 & 6)
- TR: TAPE & REEL (SEE NOTES 6 & 7) (ONLY AVAILABLE WITHOUT -PF OPTION)
- FR: FULL REEL QTY TAPE & REEL (SEE NOTES 6 & 7) (ONLY AVAILABLE WITHOUT -PF OPTION)

OPTION

- PF: PANEL FLANGE (SEE SHT 3, FIG. 4)
- L: LOCKING OPTION (ONLY AVAILABLE ON HDMR-19-01-X-TH-PF-L, SEE SHT 3, FIG 5 & HDMR-29-01-X-TH-PF-L, SEE SHT 4 FIG 8)

LEAD TERMINATION

- SM: SURFACE MOUNT
- TH: THROUGH HOLE (ONLY AVAILABLE ON HDMR-19-01-X-TH-PF-L)(SEE SHT 3, FIG 3)

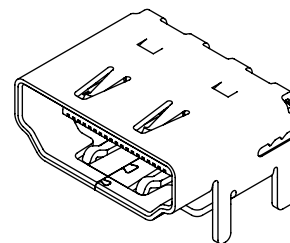
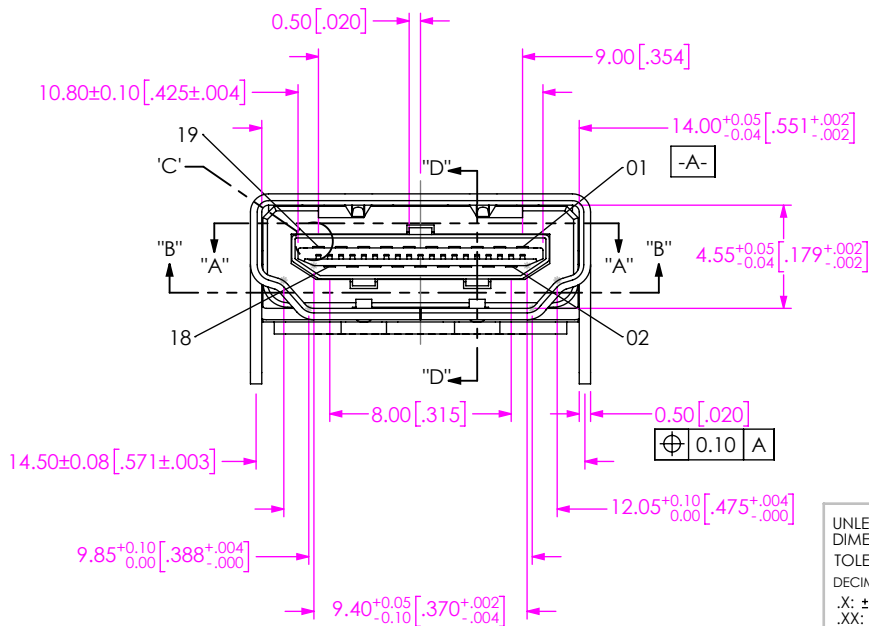
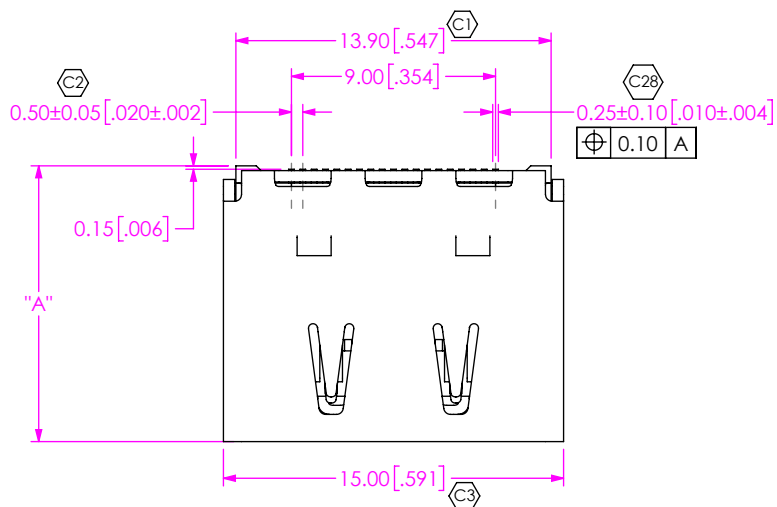

TABLE 1		
AVAIL. CONFIGURATIONS	"A"	"B"
HDMR-19-01-X-SM	12.16	5.96
HDMR-19-02-X-SM	12.16	5.96
HDMR-19-01-X-SM-PF	12.16	5.96
HDMR-19-02-X-SM-PF	12.16	5.96
HDMR-19-01-X-TH-PF-L	12.25	6.00
HDMR-29-01-X-SM	SEE SHT 4	
HDMR-29-01-X-SM-PF	SEE SHT 4	

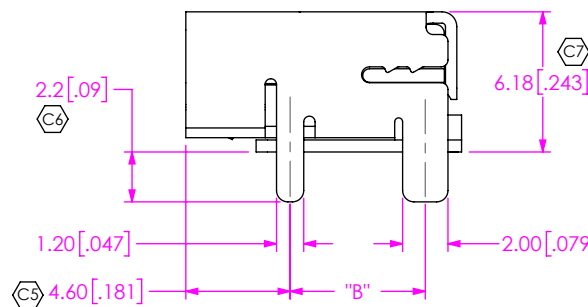

FIG 1
HDMR-19-01-X-SM SHOWN

UNLESS OTHERWISE SPECIFIED, DIMENSIONS ARE IN MM. TOLERANCES ARE:
DECIMALS ANGLES
.X: ±0.25[.010] 1°
.XX: ±0.20[.008]
.XXX: ±0.10[.004]

PROPRIETARY NOTE

THIS DOCUMENT CONTAINS CONFIDENTIAL AND PROPRIETARY INFORMATION AND ALL DESIGN, MANUFACTURING, REPRODUCTION, USE, PATENT RIGHTS AND SALES RIGHTS ARE EXPRESSLY RESERVED BY SAMTEC, INC. THIS DOCUMENT SHALL NOT BE DISCLOSED, IN WHOLE OR PART, TO ANY UNAUTHORIZED PERSON OR ENTITY NOR REPRODUCED, TRANSFERRED OR INCORPORATED IN ANY OTHER PROJECT IN ANY MANNER WITHOUT THE EXPRESS WRITTEN CONSENT OF SAMTEC, INC.

DO NOT SCALE DRAWING SHEET SCALE: 1:0.333333

MATERIAL:
INSULATOR: HIGH TEMP THERMOPLASTIC (UL94V-0)
CONTACT: COPPER ALLOY
SHELL: NICKEL PLATED BRASS



520 PARK EAST BLVD, NEW ALBANY, IN 47150
PHONE: 812-944-6733 FAX: 812-948-5047
e-Mail info@SAMTEC.com code 55322

DESCRIPTION: HDMI RECEPTACLE
DWG. NO. HDMR-XX-XX-X-XX-XX-XX
BY: B. PERRY 9/14/07 SHEET 1 OF 4

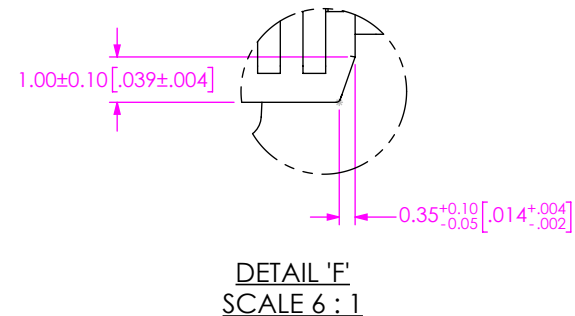
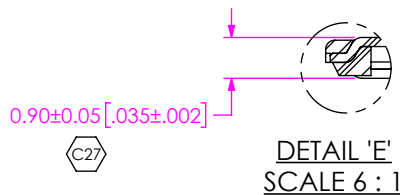
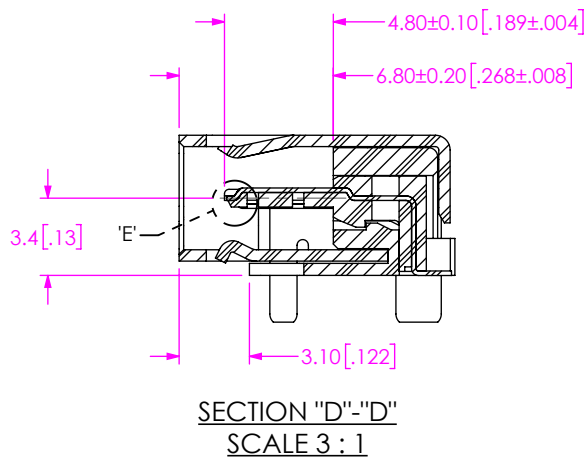
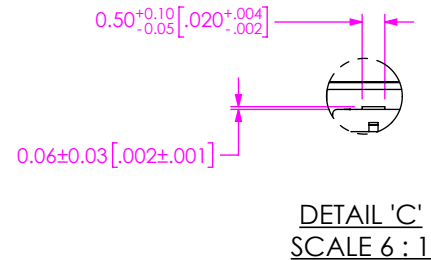
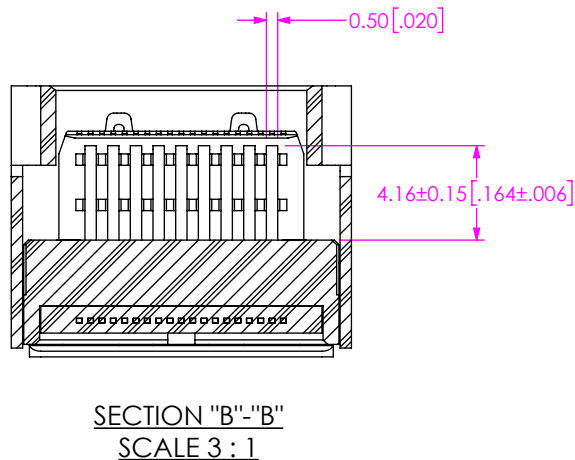
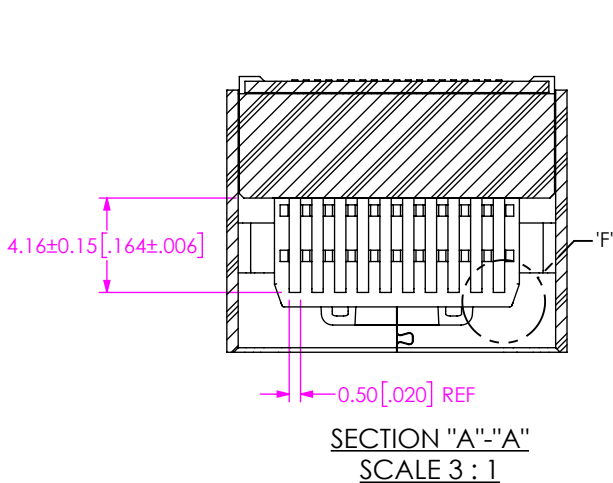

PROPRIETARY NOTE
 THIS DOCUMENT CONTAINS CONFIDENTIAL AND PROPRIETARY INFORMATION AND ALL DESIGN, MANUFACTURING, REPRODUCTION, USE, PATENT RIGHTS AND SALES RIGHTS ARE EXPRESSLY RESERVED BY SAMTEC, INC. THIS DOCUMENT SHALL NOT BE DISCLOSED, IN WHOLE OR PART, TO ANY UNAUTHORIZED PERSON OR ENTITY NOR REPRODUCED, TRANSFERRED OR INCORPORATED IN ANY OTHER PROJECT IN ANY MANNER WITHOUT THE EXPRESS WRITTEN CONSENT OF SAMTEC, INC.

samtec
 520 PARK EAST BLVD, NEW ALBANY, IN 47150
 PHONE: 812-944-6733 FAX: 812-948-5047
 e-Mail info@SAMTEC.com code 55322

DO NOT SCALE DRAWING
 SHEET SCALE: 1:0.333333

DESCRIPTION: HDMI RECEPTACLE
 DWG. NO. HDMR-XX-XX-X-XX-XX-XX
 BY: B. PERRY 9/14/07 SHEET 2 OF 4

FIG 2
-02 SHIELD TAIL STYLE
(HDMR-19-02-X-SM SHOWN)
(DIFFERENT AS SHOWN, OTHERWISE SAME AS FIG 1))

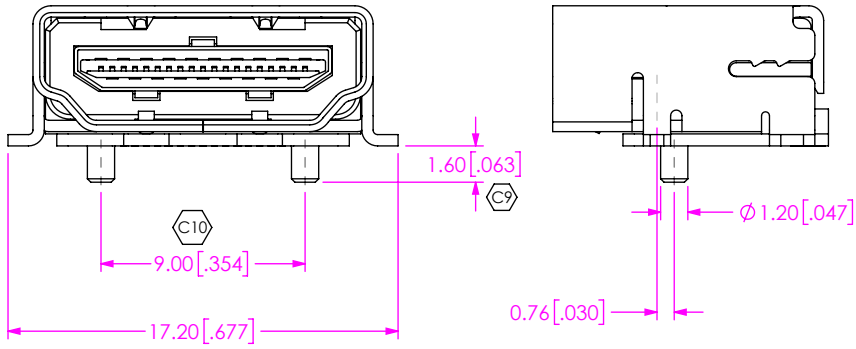

FIG 3
-TH LEAD TERMINATION STYLE
(ONLY AVAILABLE ON HDMR-19-01-X-TH-PF-L)
(DIFFERENT AS SHOWN, OTHERWISE SAME AS FIG 1))

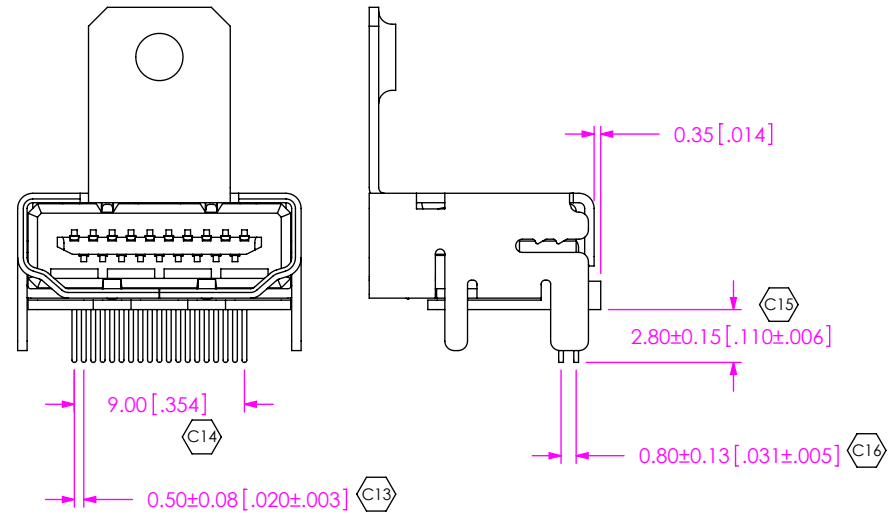
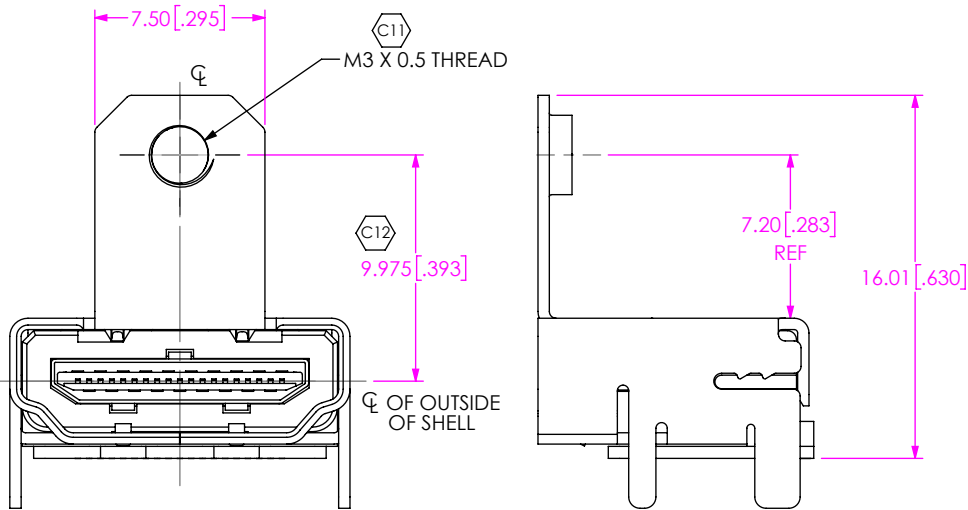
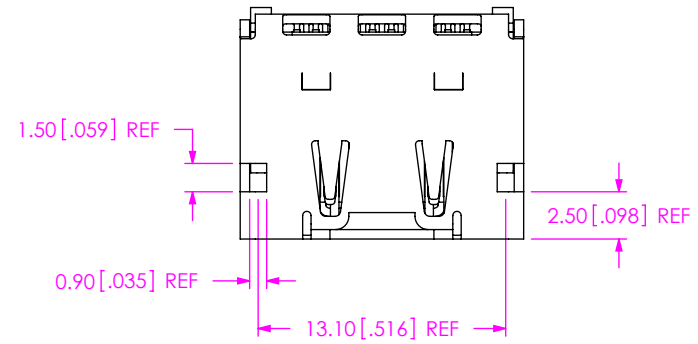

FIG 5
-L: LOCKING LEADS
(ONLY AVAILABLE ON HDMR-19-01-X-TH-PF-L)
(DIFFERENT AS SHOWN, OTHERWISE SAME AS FIG 1))



PROPRIETARY NOTE
THIS DOCUMENT CONTAINS CONFIDENTIAL AND PROPRIETARY INFORMATION AND ALL DESIGN, MANUFACTURING, REPRODUCTION, USE, PATENT RIGHTS AND SALES RIGHTS ARE EXPRESSLY RESERVED BY SAMTEC, INC. THIS DOCUMENT SHALL NOT BE DISCLOSED, IN WHOLE OR PART, TO ANY UNAUTHORIZED PERSON OR ENTITY NOR REPRODUCED, TRANSFERRED OR INCORPORATED IN ANY OTHER PROJECT IN ANY MANNER WITHOUT THE EXPRESS WRITTEN CONSENT OF SAMTEC, INC.

DO NOT SCALE DRAWING

SHEET SCALE: 3:1



520 PARK EAST BLVD, NEW ALBANY, IN 47150
PHONE: 812-944-6733 FAX: 812-948-5047
e-Mail info@SAMTEC.com code 55322

DESCRIPTION:
HDMI RECEPTACLE

DWG. NO.
HDMR-XX-XX-X-XX-XX-XX

BY: B. PERRY 9/14/07 SHEET 3 OF 4

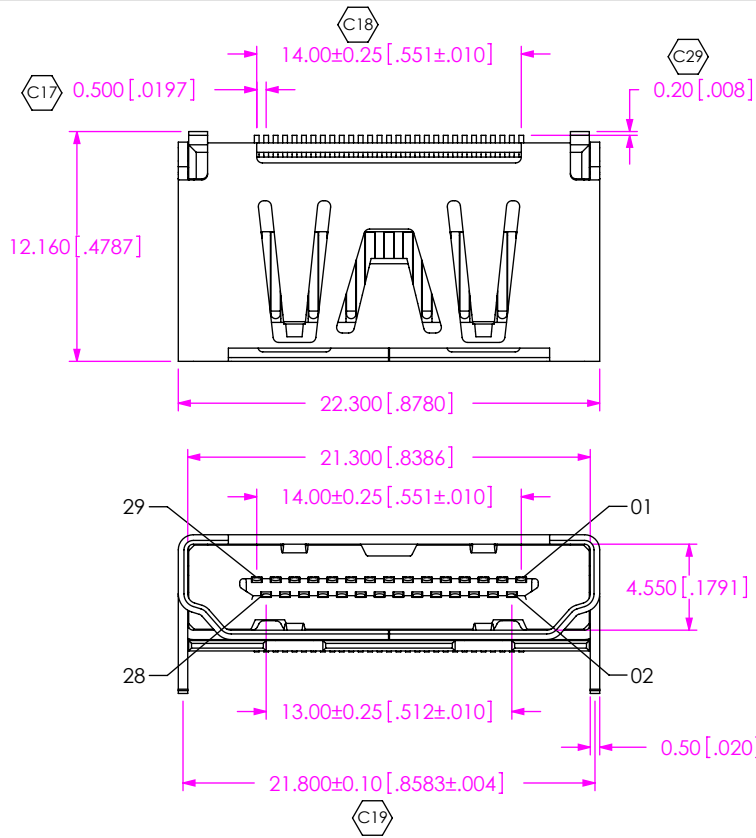

FIG 6
HDMR-29-01-X-SM SHOWN

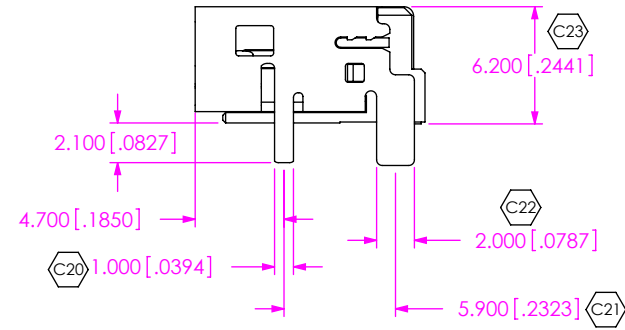
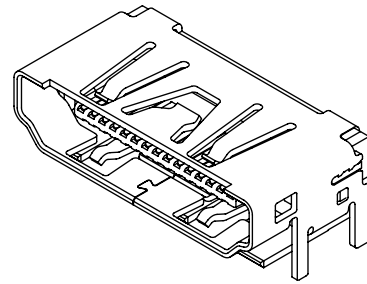

FIG 7
HDMR-29-01-X-SM-PF SHOWN
(DIFFERENT AS SHOWN, OTHERWISE SAME AS FIG 6)

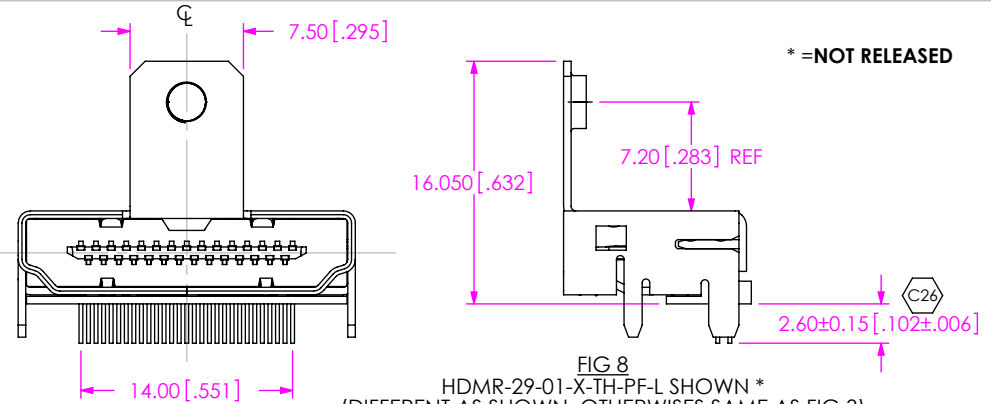
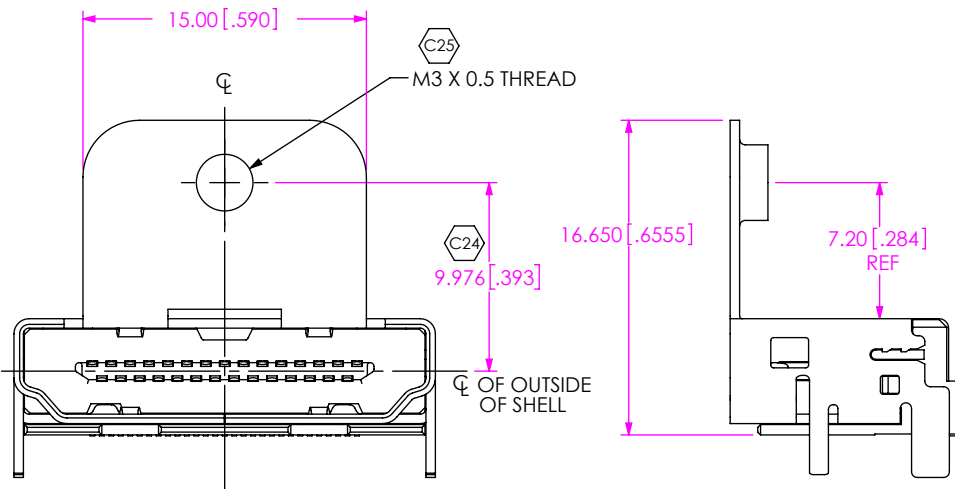

FIG 8
HDMR-29-01-X-TH-PF-L SHOWN *
(DIFFERENT AS SHOWN, OTHERWISE SAME AS FIG 3)

* =NOT RELEASED

PROPRIETARY NOTE
THIS DOCUMENT CONTAINS CONFIDENTIAL AND PROPRIETARY INFORMATION AND ALL DESIGN, MANUFACTURING, REPRODUCTION, USE, PATENT RIGHTS AND SALES RIGHTS ARE EXPRESSLY RESERVED BY SAMTEC, INC. THIS DOCUMENT SHALL NOT BE DISCLOSED, IN WHOLE OR PART, TO ANY UNAUTHORIZED PERSON OR ENTITY NOR REPRODUCED, TRANSFERRED OR INCORPORATED IN ANY OTHER PROJECT IN ANY MANNER WITHOUT THE EXPRESS WRITTEN CONSENT OF SAMTEC, INC.

DO NOT SCALE DRAWING

SHEET SCALE: 3:1

samtec

520 PARK EAST BLVD, NEW ALBANY, IN 47150
PHONE: 812-944-6733 FAX: 812-948-5047
e-Mail info@SAMTEC.com code 55322

DESCRIPTION: HDMI RECEPTACLE

DWG. NO. HDMR-XX-XX-X-XX-XX-XX

BY: B. PERRY 9/14/07 SHEET 4 OF 4