

BNC MALE - UHF FEMALE ADAPTOR

R191.445.000

Série : ADAPT

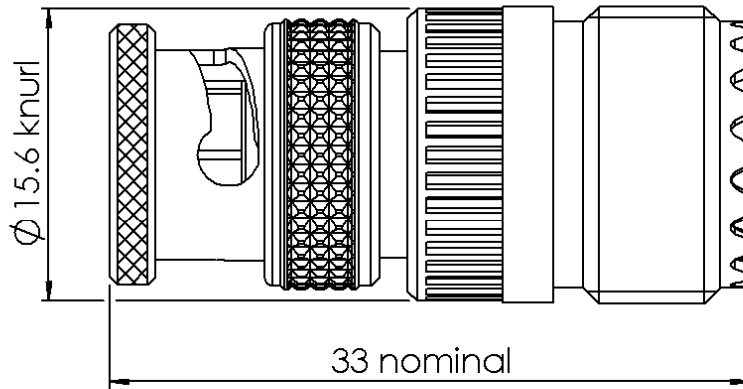

All dimensions are in mm.

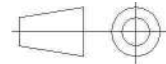

COMPONENTS	MATERIALS	PLATING (μm)
BODY	BRASS	NICKEL 2
CENTER CONTACT	BRASS	SILVER 5
OUTER CONTACT	-	-
INSULATOR	PTFE	
GASKET	SILICONE RUBBER	
OTHERS PARTS	BRASS	NICKEL 2
-	-	-
-	-	-

Issue : 1013 B

In the effort to improve our products, we reserve the rights to make changes judged to be necessary.



BNC MALE - UHF FEMALE ADAPTOR

R191.445.000

Série : ADAPT

PACKAGING

SPECIFICATION

Standard	Unit	Other
	'W' option	Contact us

ELECTRICAL CHARACTERISTICS

ENVIRONMENTAL

Impedance	50	Ω
Frequency	0-0.5	GHz
VSWR	- + 0,0000	x F(GHz) Maxi
Insertion loss		- \sqrt{F} (GHz) dB Maxi
RF leakage	- (- F(GHz)) dB Maxi
Voltage rating		- Veff Maxi
Dielectric withstanding voltage	1500	Veff mini
Insulation resistance	5000	M Ω mini

Operating	-55/+125	$^{\circ}$ C
Hermetic seal	NA	Atm.cm3/s
Panel leakage	NA	

MECHANICAL CHARACTERISTICS

OTHER CHARACTERISTICS

Center contact retention		
Axial force – Mating end	27	N mini
Axial force – Opposite end	27	N mini
Torque	NA	N.cm mini
Recommended torque		
Mating	UHF	0 N.cm
	BNC	0 N.cm
	-	0 N.cm
Panel nut	NA	N.cm
Mating life	0	Cycles mini
Weight	23,0000	g

Issue : 1013 B

In the effort to improve our products, we reserve the rights to make changes judged to be necessary.

