

Evaluating the **ADM1260** Super Sequencer with Interchip Bus and Nonvolatile Fault Recording

FEATURES

Full functional support evaluation kit for the **ADM1260**

I²C interface supports all device related software

Interchip bus simplifies multidevice cascading and sequencing operation

10 adjustable voltages reference for input emulation

Switch controlled, open-drain/push-pull digital inputs

Extra headers for easy probing

Includes point to point patch cables for easy wiring

EVAL-ADM1260EBZ EVALUATION KIT CONTENTS

EVAL-ADM1260CSZ evaluation board and sample silicons

ADM1260 device socket

8-way, 100 mm micro match ribbon cable

Patch cables

ADDITIONAL HARDWARE NEEDED

USB to I²C dongle **USB-SDP-CABLEZ**

9 V to 14.4 V power supply

SOFTWARE NEEDED

ADI Power Studio

GENERAL DESCRIPTION

The **EVAL-ADM1260CSZ** is a compact, full-feature evaluation board for the **ADM1260** that comes in the **EVAL-ADM1260EBZ** evaluation kit.

Ten programmable driver outputs, Pins PDO1 to PDO10 (PDOx), and five dual-function inputs, Pins VX1 to VX5 (VXx), along with five selectable input attenuators that allow supervision of supplies, Pins VP1 to VP4 (VPx), and Pin VH give users flexibility and allows a wide range of application setups.

Ten LEDs give users direct visual indication on variations in the input board status. There is one LED to indicate the board power supply status.

The switches on the board allow the user to change the device address easily.

The evaluation kit supports I²C communication, allowing users to communicate with the **ADM1260** devices. The evaluation kit also supports cascade setup so multiple evaluation boards can connect and share the same I²C bus.

The **EVAL-ADM1260CSZ** is fully compatible with the **ADI Power Studio™** software, to download this software, go to the **ADM1260** product page.

Users need a **USB-SDP-CABLEZ** dongle to use the evaluation software tools. Only one dongle is required in a multiboard cascade setup. One device socket is included in each kit. The **ADM1260** data sheet provides additional information and must be consulted when using the evaluation board.

TABLE OF CONTENTS

Features	1	Margining Guide	6
Evaluation Kit Contents.....	1	Quick Start Guide.....	7
Additional Hardware Needed	1	Hardware Setup	7
Software Needed.....	1	Software Graphical User Interface (GUI)	7
General Description	1	Demonstration Configuration.....	10
Revision History	2	Demo 1: Single Board Sequencing.....	10
Evaluation Board Photograph and Components	3	Demo 2: Multiple Board Sequencing (Two Boards).....	10
Evaluation Board Description.....	4	Switch, Jumper, and LED Functions	11
Supported Devices.....	4	Socket Selection Guide	13
Power Supplies	4	Evaluation Board Schematics and Artwork.....	14
Inputs Emulation.....	4	Ordering Information.....	19
Output Signal	4	Bill of Materials.....	19
I ² C Interface	5		
Multiple Board Setup	5		

REVISION HISTORY

4/16—Revision 0: Initial Version

EVALUATION BOARD PHOTOGRAPH AND COMPONENTS

See Figure 1 for the numbers described in Table 1.

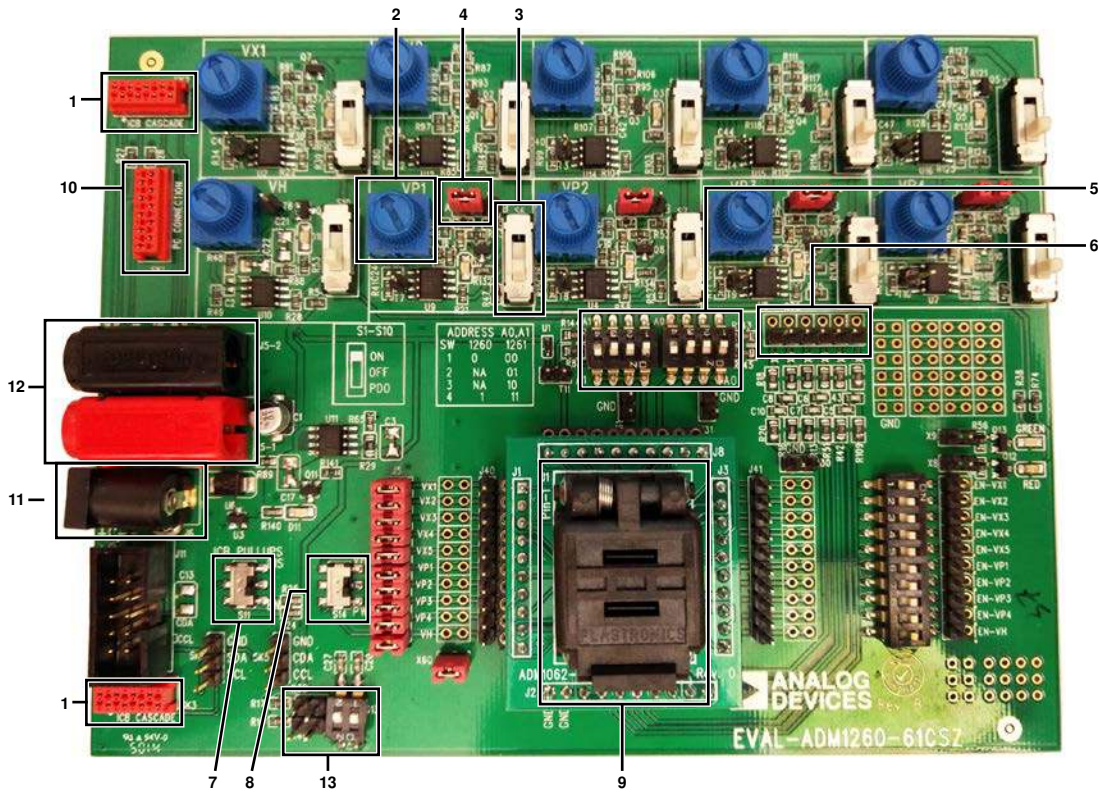

NOTES
 1. EVAL-ADM1260-61CSZ HAS THE SAME LAYOUT AND FUNCTIONALITY AS THE EVAL-ADM1260CSZ.

Figure 1. Evaluation Board Components

14257-001

Table 1. Components Required for Evaluating the ADM1260 (See Figure 1)

Number	Component	Description
1	Multiple board connector	Connects up to four ADM1260 evaluation boards together. The connector carries SMBus lines, ICB lines, and power across all the boards connected.
2	Rotating potentiometer	Varies the output voltage of the regulators, which is connected to the voltage sensing pins of the ADM1260 .
3	Voltage regulator enable selection	Selects the enable signal for the voltage regulators. There are three selection options: the bottom position selects the enable signal from the PDOx pins; the middle position turns off the voltage regulator manually; and the top position enables the voltage regulator manually.
4	Range selection for VPx pins	Selects the high or low range for the VPx pins. Position A and Position B on the board denotes Position H and Position, L, respectively.
5	Address selection switches	Selects the SMBus address for the ADM1260 . For more details, refer to Table 3.
6	DAC outputs	These are the DAC outputs on the ADM1260 . These pins can connect to the feedback node of the voltage regulators for margining.
7	ICB pull-up switch	Always set this to EN (bottom position) to pull up the ICB lines.
8	Chip power switch	This switch powers the chip using 12 V or connects to the VH voltage regulator.
9	Socket	ADM1260 silicon is placed in the socket and gives the user easy replaceability.
10	I ² C dongle connector	Connects the USB-SDP-CABLEZ dongle to the board for programming the ADM1260 (I ² C dongle must be purchased separately).
11	Power adapter connector	Connect the power adapter connector to the wall power adapter to power the evaluation board.
12	Bench power supply connector	Connects the bench power supply to power up the board.
13	Switch for digital inputs	Emulates digital inputs.

EVALUATION BOARD DESCRIPTION

The [EVAL-ADM1260CSZ](#) evaluation board is designed for evaluating the [ADM1260](#) Super Sequencer® IC. The board is easy to use, easy to probe, allows flexible wiring, and is capable of supporting large multidevice systems by cascading multiple boards.

SUPPORTED DEVICES

The evaluation board is designed to support the [ADM1260](#) when the silicon is placed in the [SOCKET-ADM106XLFZ](#) daughter card.

POWER SUPPLIES

The evaluation board can accept 9 V to 14.4 V from a bench power supply through Connector J5-1 and Connector J5-2. It also supports a wall mountable switching power supply with the voltage range 9 V to 14.4 V using Connector J6. Connector J6 is grounded and has reverse voltage protection circuits to prevent damage due to incorrect polarity. The current consumption of a single board depends on the exact configuration of the board and sequence, but the consumption is typically less than 200 mA.

INPUTS EMULATION

Ten on-board adjustable voltage regulators from Analog Devices provide input supply emulation for all different setups supported by the [ADM1260](#).

Each regulator operates independently and the output voltages can be easily adjusted by hand using an on-board, rotating potentiometer.

Every regulator can be enabled or disabled by the user or by the [ADM1260](#) device, depending on the selection switch configuration. There is an LED to indicate the on/off status for each regulator.

All regulators have a feedback pin that allows the user to evaluate the margining function of the [ADM1260](#).

An additional on-board, two-way, push-pull/open-drain switch, S13, can emulate digital inputs, if required.

OUTPUT SIGNAL

PDOx output signals from the [ADM1260](#) can easily connect to the regulator enabled control circuits on the board to control the on-board voltage regulators. The user can easily link the PDOx output signal to a regulator enable input by using the 10 switches S12 comprises. Linking the PDOx output signal to a regulator enable input allows the board to perform simulations for real-world sequencing applications.

The digital-to-analog converter (DAC) output signals can be wired to the feedback node of the regulators on the board to achieve supply margining.

The wiring of the DAC output to the feedback node of the regulator is made easy with the point to point patch cables included in the evaluation kit. The user can easily connect the DAC outputs of the [ADM1260](#) to a regulator feedback node.

I²C INTERFACE

The evaluation board supports an I²C interface. The user can connect the I²C end of the dongle from the PC USB port to the board using the [USB-SDP-CABLEZ](#). The dongle has internal pull-ups for the SDA and SCL bus.

MULTIPLE BOARD SETUP

Connector SK2, Connector SK3, and the eight-way ribbon cable allow up to four [EVAL-ADM1260CSZ](#) boards to connect to evaluate complex cascade sequencing setups.

A connection cable carries power and the interchip bus (ICB) to every board that is connected together. The user must only connect the power and the [USB-SDP-CABLEZ](#) to one board. It is recommended to connect the power supply to the board in the middle of a multiple board setup to ensure even power dissipation in the traces/cables.

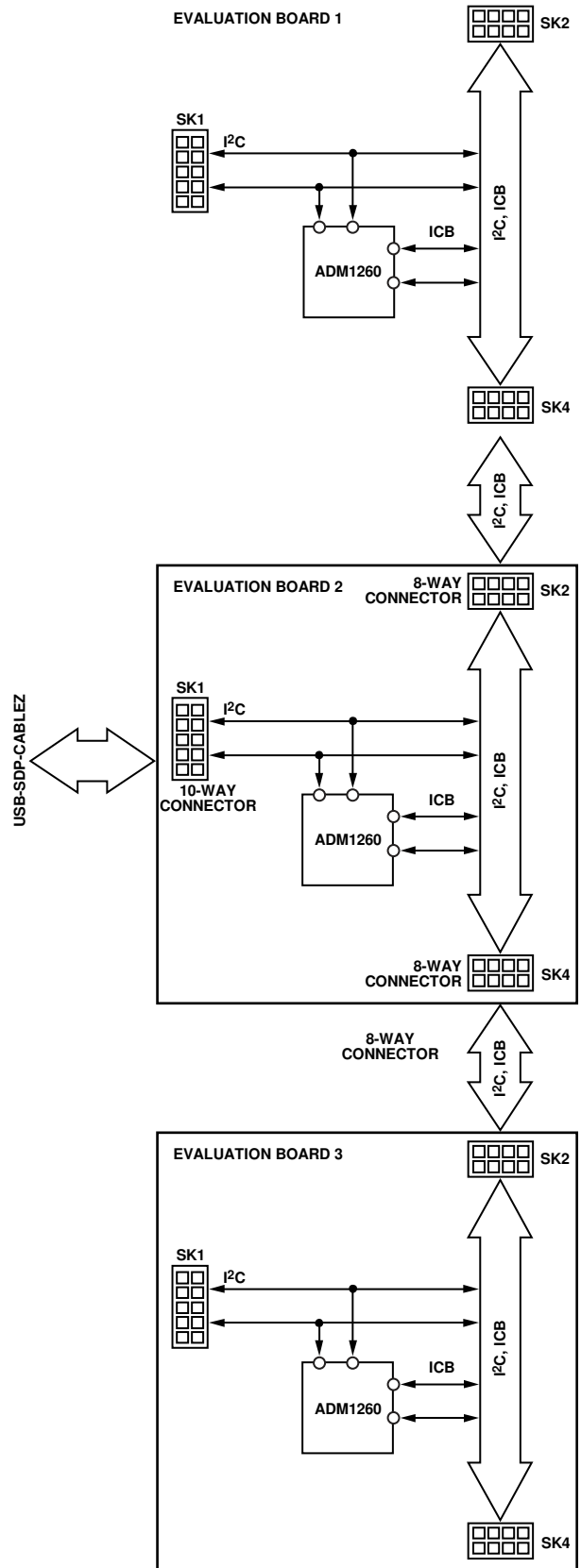

Figure 2. Multiple Boards Connection

14257-002

MARGINING GUIDE

The [ADP7102](#) LDO in the evaluation board provides adjustable V_{Xx} and V_{Px} input voltages to the V_{Xx} and V_{Px} pins.

The DAC1, DAC2, and DAC3 outputs, labeled on the board as X1, X2, and X3, are designed for V_{Xx} supply margining to the board. The DAC4 and DAC5 outputs, labeled on the board as X4 and X5, are designed for V_{Px} supply margining. DAC6, labeled on the board as X6, is designed for VH supply margining.

For margining the supplied voltage, the output of the DACs must connect to the feedback node of the LDOs. The connectors to the V_{Xx} feedback nodes are labeled T1 to T5, the V_{Px} feedback nodes are labeled T7 to T10, and the VH feedback node is labeled T6.

The reference voltage of the [ADP7102](#) is 1.22 V, so the midcode of the DACs must be set as 1.25 V to achieve the highest maximum and minimum range for margining the rails.

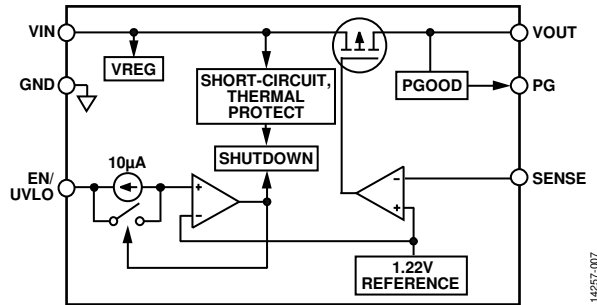

Figure 3. [ADP7102](#) Functional Diagram

QUICK START GUIDE

HARDWARE SETUP

- Put Jumpers J1, J2, J3, and J4 into Position H on the board. This puts the output of the VPx regulators to higher voltage ranges.
- All the jumpers comprised in the J5 jumper must be populated since J5 connects the output of the voltage regulator to the respective input pins, VPx, VXx, and VH, of the sequencer.
- Put Switches S1 to S10 into the bottom position. This enables the voltage regulators connected to the Pin VXx and Pin VPx input to be controlled by an external signal such as the PDOx pins of the [ADM1260](#).
- Set all the switches S12 comprises to the on position which connects the PDOx pins to the enable pins, EN-VXx, EN-VPx, and EN-VH, of the LDO in the board of the voltage regulator as shown in Table 2.

Table 2 PDOx Mapping

Connection Point	Connected To
PDO1	EN-VX1
PDO2	EN-VX2
PDO3	EN-VX3
PDO4	EN-VX4
PDO5	EN-VX5
PDO6	EN-VP1
PDO7	EN-VP2
PDO8	EN-VP3
PDO9	EN-VP4
PDO10	EN-VH

- Set Switch S11 to EN, enabling pull-up on the ICB bus and set Switch S14 to PWR so the VH pin on the [ADM1260](#) is directly connected to the supply voltage, 12 V.
- Set the SMBus address to the required address. Table 3 shows the configuration for Switches A0 and A1 for different addresses.

Table 3. SMBus Address Configuration

Address	A1				A0			
	1	2	3	4	1	2	3	4
0x34	On	Off	Off	Off	On	Off	Off	Off
0x35	On	Off	Off	Off	Off	Off	Off	On
0x36	Off	Off	Off	On	On	Off	Off	Off
0x37	Off	Off	Off	On	Off	Off	Off	On

SOFTWARE GRAPHICAL USER INTERFACE (GUI)

Overview

[ADI Power Studio](#) is a free software tool for programming and configuring the [ADM1260](#). It can be downloaded from the [ADM1260](#) product page on the Analog Devices website. The software package includes a GUI evaluation tool and a USB to the [USB-SDP-CABLEZ](#) I²C dongle driver.

GUI Installation

Connect the USB cable to the dongle only after the software installs.

- Install the [ADM1260](#) software GUI. Double-click the **ADI Power Studio vx.x.x.x Setup.exe** installation file to start the installation.
- When the **License Agreement** window appears, click **I Agree** to continue.
- In the **ADI Power Studio Setup: Installation Options** window, see Figure 4, **ADI Power Studio (required)**, **USB-SDP-CABLEZ Driver**, and **Create Start Menu Shortcuts** are preselected. If the [USB-SDP-CABLEZ](#) driver is already installed, uncheck the **USB-SDP-CABLEZ Driver** checkbox.

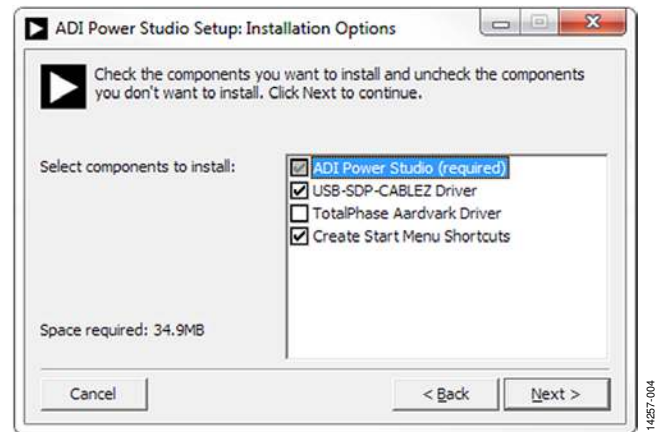

Figure 4. Installation Options

- In the **ADI Power Studio Setup: Installation Folder** window, there is an option to select a custom installation location, as seen in Figure 5. Click **Browse** to navigate to the preferred installation location (optional). Click **Install** to install the GUI onto the computer.

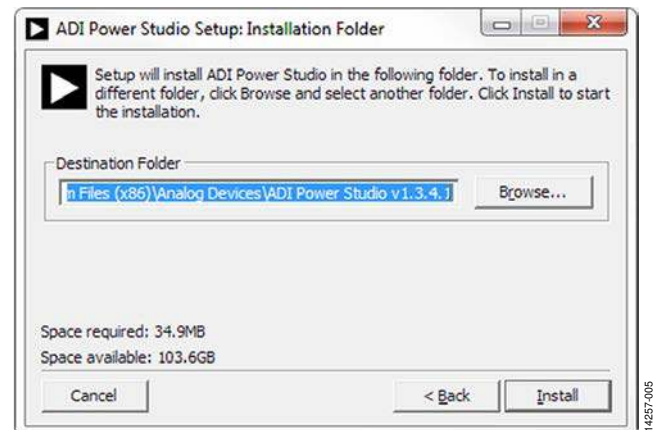

Figure 5. Installation Location

- When the progress bar is 100% after clicking **Install** and says **Completed**, click **Close** to finish the installation process; see Figure 6.

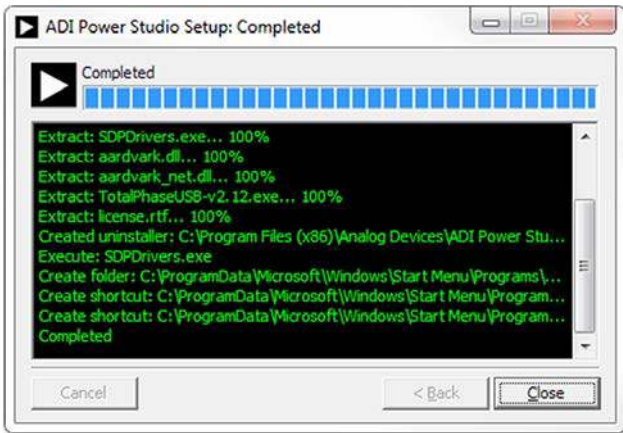

Figure 6. Installation Complete Window

Loading the Demo Configuration

Connect the evaluation board to the computer using the [USB-SDP-CABLEZ](#) I²C dongle. Launch the ADI Power Studio software by clicking **Start Menu > All Programs > Analog Devices > ADI Power Studio vX.Y.Z > ADI Power Studio**.

In Figure 7, when the GUI launches, a pop-up window shows the I²C dongle and the [ADM1260](#) is detected. Click **OK** to proceed. For a single board demo, ensure the device address is set to 0x34; for a two board demo, set the device address to 0x34 and 0x35.

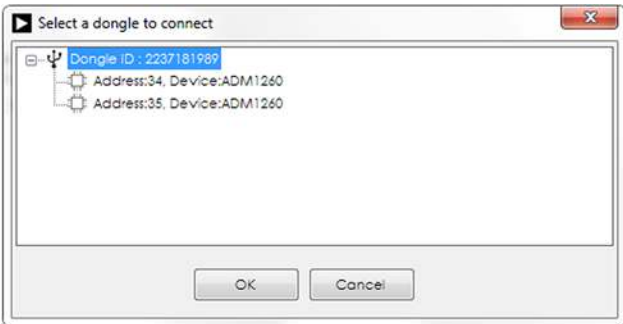

Figure 7. Connecting the to the [ADM1260](#)

In the **Welcome** tab, Figure 8, click **Open Project** and navigate to the location where the demo files are located and select the *.ssp demo file. To download the demo configuration files, go to the [ADM1260](#) product page.



Figure 8. **Welcome** Tab

If the configuration on the connected [ADM1260](#) is different than the configuration file that is being loaded, a pop-up window appears; see Figure 9. Click **Yes** to program the device.



Figure 9. Device Program Pop-Up Window

Once the device or devices are programmed, the sequence automatically runs. To see the sequence configuration, click **Sequencing** on the top menu, which opens the **Sequence and State Configuration** window in Figure 10.

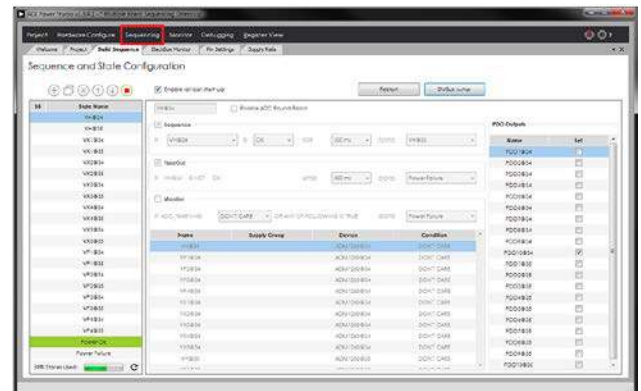

Figure 10. **Sequence and State Configuration** Window

The input undervoltage (UV) and overvoltage (OV) thresholds can be modified by clicking the **Hardware Configure** tab and selecting the **Supply Rails** tab. The **Supply Rails** tab, as seen in Figure 11, shows a summary of all the voltage inputs and the PDOx outputs used for enabling the voltage rails. The supply monitor configuration, such as OV, UV, and PDOx, can be modified in the **Properties** menu on the right side of the window.

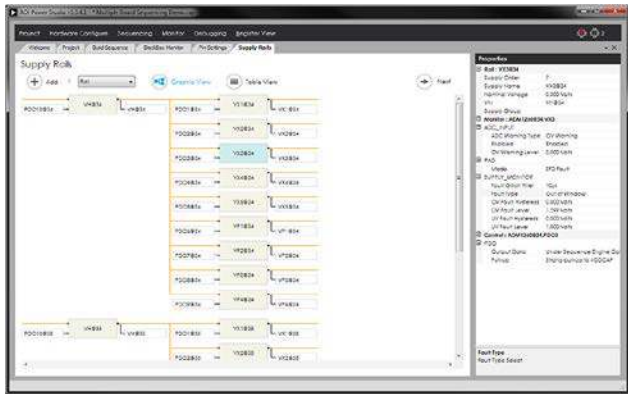

Figure 11. Supply Rails Tab

Real-time voltage reading and the status for the supplies can be read back in the **Pin Status Monitor** tab, Figure 12, which can be accessed under the **Monitor** menu.



Figure 12. Pin Status Monitor Tab

DEMONSTRATION CONFIGURATION

To download the demo configuration files, go to the [ADM1260](#) product page. The file contains two configuration files: one demonstrates the single device functionality of the [ADM1260](#) and the other demonstrates multiple device functionality of [ADM1260](#).

DEMO 1: SINGLE BOARD SEQUENCING

In this demonstration, the PDOx signals are turned on one by one by the sequence configuration to enable the voltage regulators. The VXx rails are the first to come up followed by the VPx rails. The [ADM1260](#) is powered by the VH rails in this particular demo, which is done by setting Switch S14 to PWR. Set the device address to 0x34; refer to Table 3 for more information.

The sequence engine turns on a rail and checks if that particular rail has either an undervoltage (UV) or overvoltage (OV) fault. If there is no fault in the rail for 200 ms, the sequence proceeds to the next rail until all the rails are up. If either the UV or OV fault persists in the rails that the sequence engine is trying to sequence, the sequence engine times out after 400 ms and tries to sequence all the rails again.

If a fault happens in any of the rails that are already powered up while the sequence engine is sequencing or is in the power good state, the sequence engine jumps to the power fail state and tries to sequence the rails. In the power fail state, the [ADM1260](#) does a black box write.

The OV thresholds are set to 1.30 V for the VXx pins and 3.5 V for the VPx pins. UV thresholds are set to 1.00 V for the VXx pins and 3.1 V for the VPx pins. For the demonstration configuration to sequence as expected, the voltage for the VXx pins and VPx pins must be set in within the UV and OV thresholds.

DEMO 2: MULTIPLE BOARD SEQUENCING (TWO BOARDS)

This demonstration shows sequencing across three boards and the function of ICB bus. Three boards must connect serially using the SK2 and SK3 ports. The boards must have an SMBus address of 0x34 and 0x35. When multiple evaluation boards are connected together, only one I²C dongle and power source is required since the serial connecting cable carries the power, the I²C lines, and the ICB lines across the boards.

The sequence configuration for this demo enables the PDOx signals one by one to enable the LDOs. The VXx rails on the [ADM1260](#) are the first to come up followed by the VPx rails. The sequence configuration is made to enable one rail per device in every state, showing the robustness of multidevice sequencing. The sequence enables Pin VX1 on Device 0x34, followed by Pin VX1 on Device 0x35, Pin VX2 on Device 0x34, and so on.

The sequence engine turns on a rail and checks if that particular rail has a UV or OV fault. If there is no fault for 200 ms, the sequence engine proceeds to the next rail until all the rails are powered up on the three boards. If either the UV or OV fault persists in the rail that the sequence engine is trying to sequence, the sequence engine times out after 400 ms and tries to sequence all the rails again.

If a fault happens in any of the rails that are already powered up while the sequence engine is sequencing or in the power good state, all three devices jump to the power fail state and try to sequence the rails again.

The OV thresholds are set to 1.30 V for the VXx pins and 3.5 V for the VPx pins. The UV thresholds are set to 1.00 V for the VXx pins and 3.1 V for the VPx pins. For the demonstration configuration to sequence as expected, the voltage for the VXx pins and VPx pins must be set in between the UV and OV thresholds.

SWITCH, JUMPER, AND LED FUNCTIONS

Table 4. Switch Functions

Designator	Switch	Description	Default
A0	1	Device address switch A0. On: Address Pin A0 pulled down to ground.	On
	2	On: Address Pin A0 pulled down to ground through a 150 kΩ resistor.	Off
	3	On: Address Pin A0 floating to allow maximum leakage current.	Off
	4	On: Address Pin A0 pulled up to VDDCAP through a 150 kΩ resistor.	Off
A1	1	Device address switch A1. On: Address Pin A1 pulled down to ground.	On
	2	On: Address Pin A1 pulled down to ground through a 150 kΩ resistor.	Off
	3	On: Address Pin A1 floating to allow maximum leakage current.	Off
	4	On: Address Pin A1 pulled up to VDDCAP through a 150 kΩ resistor.	Off
S13	1	Optional digital input switch. Use in conjunction with X49. X49 connected: push-pull. X49 disconnected: open-drain. On: X49 pulled to ground. Off: X49 pulled to 3.3 V/high impedance.	Disconnected Disconnected Off Off
	2	Use in conjunction with X32. X32 connected: push-pull. X32 disconnected: open-drain. On: X32 pulled to ground. Off: X32 pulled to 3.3 V/high impedance.	Disconnected Disconnected Off Off
S11	Not applicable	Controls the cascade bus pull-up. Position EN: pull-up ICB data CDA and clock CCL line to 3.3 V. Position DIS: keep cascade bus data and clock line floating.	Position EN
S1 to S10	Not applicable	Regulator control switch. Position Top: regulator always on. Position Middle: regulator shutdown. Position Bottom: regulator controlled by the PDOx output signal of the ADM1260 .	Position bottom
S14	Not applicable	Controls the source voltage connected to the VH pin of the ADM1260 . Position VH: connect the VH pin to the on-board VH regulator. Position PWR: connect the VH pin directly to the board supply.	Position PWR
S12	1 to 10	Turn on the enable PDOx outputs of the ADM1260 to control the enabling/disabling of the regulators.	On

Table 5. Jumper Functions

Jumper	Corresponding Regulator/Rails	Description	Default
J1 to J4 ¹	VP1 to VP4 ¹	Regulator output voltage divider control jumpers. Position H: regulator output range 1.5 V to 6 V. Position L: regulator output range 0.5 V to 1.5 V. Unplugged: disconnect regulator output.	Position H
J5	VXx/VPx/VH	Connects the LDO outputs to the device inputs.	All 10 populated
J40	VXx/VPx/VH	Connector used for device inputs probing.	Not applicable
J41	PDOx	Connector used for device outputs probing.	Not applicable

¹ J1 corresponds to VP1, J2 corresponds to VP2, J3 corresponds to VP3, and J4 corresponds to VP4.

Table 6. Power Indication LED Functions¹

LED	Rails
D10	VH
D1	VX1
D2	VX2
D3	VX3
D4	VX4
D5	VX5
D6	VP1
D7	VP2
D8	VP3
D9	VP4
D11	Board 3V3 supply

¹ On position indicates voltage on corresponding rail.

Table 7. Patching Through-Hole Connection Points

Connection Points	Connected To	Description
VX1	VX1 pin	Input Connection VX1.
VX2	VX2 pin	Input Connection VX2.
VX3	VX3 pin	Input Connection VX3.
VX4	VX4 pin	Input Connection VX4.
VX5	VX5 pin	Input Connection VX5.
VP1	VP1 pin	Input Connection VP1.
VP2	VP2 pin	Input Connection VP2.
VP3	VP3 pin	Input Connection VP3.
VP4	VP4 pin	Input Connection VP4.
VH	VH pin	Input Connection VH.
PDO1	PDO1 pin	Output Connection PDO1.
PDO2	PDO2 pin	Output Connection PDO2.
PDO3	PDO3 pin	Output Connection PDO3.
PDO4	PDO4 pin	Output Connection PDO4.
PDO5	PDO5 pin	Output Connection PDO5.
PDO6	PDO6 pin	Output Connection PDO6.
PDO7	PDO7 pin	Output Connection PDO7.
PDO8	PDO8 pin	Output Connection PDO8.
PDO9	PDO9 pin	Output Connection PDO9.
PDO10	PDO10 pin	Output Connection PDO10.
EN-VX1	VX1 regulator	Connect the EN-VX1 enable circuit to the PDOx outputs directly to allow the devices to take control of the VX1 regulator.
EN-VX2	VX2 regulator	Connect the EN-VX2 enable circuit to the PDOx outputs directly to allow the devices to take control of the VX2 regulator.
EN-VX3	VX3 regulator	Connect the EN-VX3 enable circuit to the PDOx outputs directly to allow the devices to take control of the VX3 regulator.
EN-VX4	VX4 regulator	Connect the EN-VX4 enable circuit to the PDOx outputs directly to allow the devices to take control of the VX4 regulator.
EN-VX5	VX5 regulator	Connect the EN-VX5 enable circuit to the PDOx outputs directly to allow the devices to take control of the VX5 regulator.
EN-VP1	VP1 regulator	Connect the EN- VP1 enable circuit to the PDOx outputs directly to allow the devices to take control of the VP1 regulator.
EN-VP2	VP2 regulator	Connect the EN- VP2 enable circuit to the PDOx outputs directly to allow the devices to take control of the VP2 regulator.
EN-VP3	VP3 regulator	Connect the EN- VP3 enable circuit to the PDOx outputs directly to allow the devices to take control of the VP3 regulator.
EN-VP4	VP4 regulator	Connect the EN- VP4 enable circuit to the PDOx outputs directly to allow the devices to take control of the VP4 regulator.

Connection Points	Connected To	Description
EN-VH	VH regulator	Connect the EN-VH enable circuit to the PDOx outputs directly to allow the devices to take control of the VH regulator.
X1	DAC1 pin	DAC Output 1.
X2	DAC2 pin	DAC Output 2.
X3	DAC3 pin	DAC Output 3.
X4	DAC4 pin	DAC Output 4.
X5	DAC5 pin	DAC Output 5.
X6	DAC6 pin	DAC Output 6.
T6	Feedback pin of the VH regulator	Connected to the feedback pin of the VH regulator; connect to X6 for supply margining (see the Margining Guide section).
T1	Feedback pin of the VX1 regulator	Connected to the feedback pin of the VX1 regulator; connect to X1 to X3 for supply margining (see the Margining Guide section).
T2	Feedback pin of the VX2 regulator	Connected to the feedback pin of the VX2 regulator; connect to X1 to X3 for supply margining (see the Margining Guide section).
T3	Feedback pin of the VX3 regulator	Connected to the feedback pin of the VX3 regulator; connect to X1 to X3 for supply margining (see the Margining Guide section).
T4	Feedback pin of the VX4 regulator	Connected to the feedback pin of the VX4 regulator; connect to X1 to X3 for supply margining (see the Margining Guide section).
T5	Feedback pin of the VX5 regulator	Connected to the feedback pin of the VX5 regulator; connect to X1 to X3 for supply margining (see the Margining Guide section).
T7	Feedback pin of the VP1 regulator	Connected to the feedback pin of the VP1 regulator; connect to X4 and X5 for supply margining (see the Margining Guide section).
T8	Feedback pin of the VP2 regulator	Connected to the feedback pin of the VP2 regulator; connect to X4 and X5 for supply margining (see the Margining Guide section).
T9	Feedback pin of the VP3 regulator	Connected to the feedback pin of the VP3 regulator; connect to X4 and X5 for supply margining (see the Margining Guide section).
T10	Feedback pin of the VP4 regulator	Connected to the feedback pin of the VP4 regulator; connect to X4 and X5 for supply margining (see the Margining Guide section).
X49	S3-1	Optional Digital Input 1. Can be set as open-drain or push-pull.
X32	S3-2	Optional Digital Input 2. Can be set as open-drain or push-pull.

SOCKET SELECTION GUIDE

Table 8.

Model	Description	Corresponding Devices
SOCKET-ADM106XLFZ	ADM1260 daughter card	ADM1260 in LFCSP

EVALUATION BOARD SCHEMATICS AND ARTWORK

14257-008

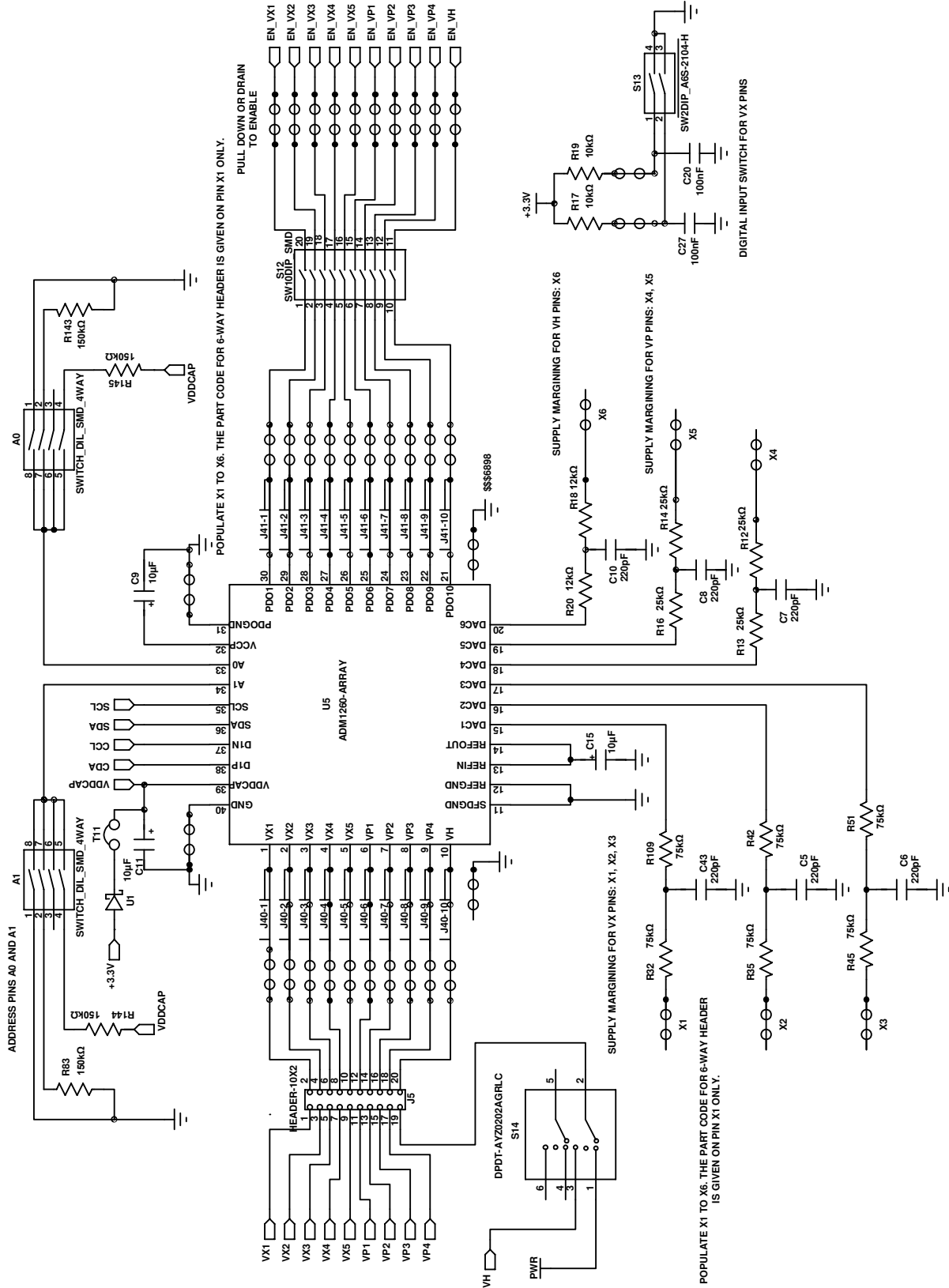

14257-009

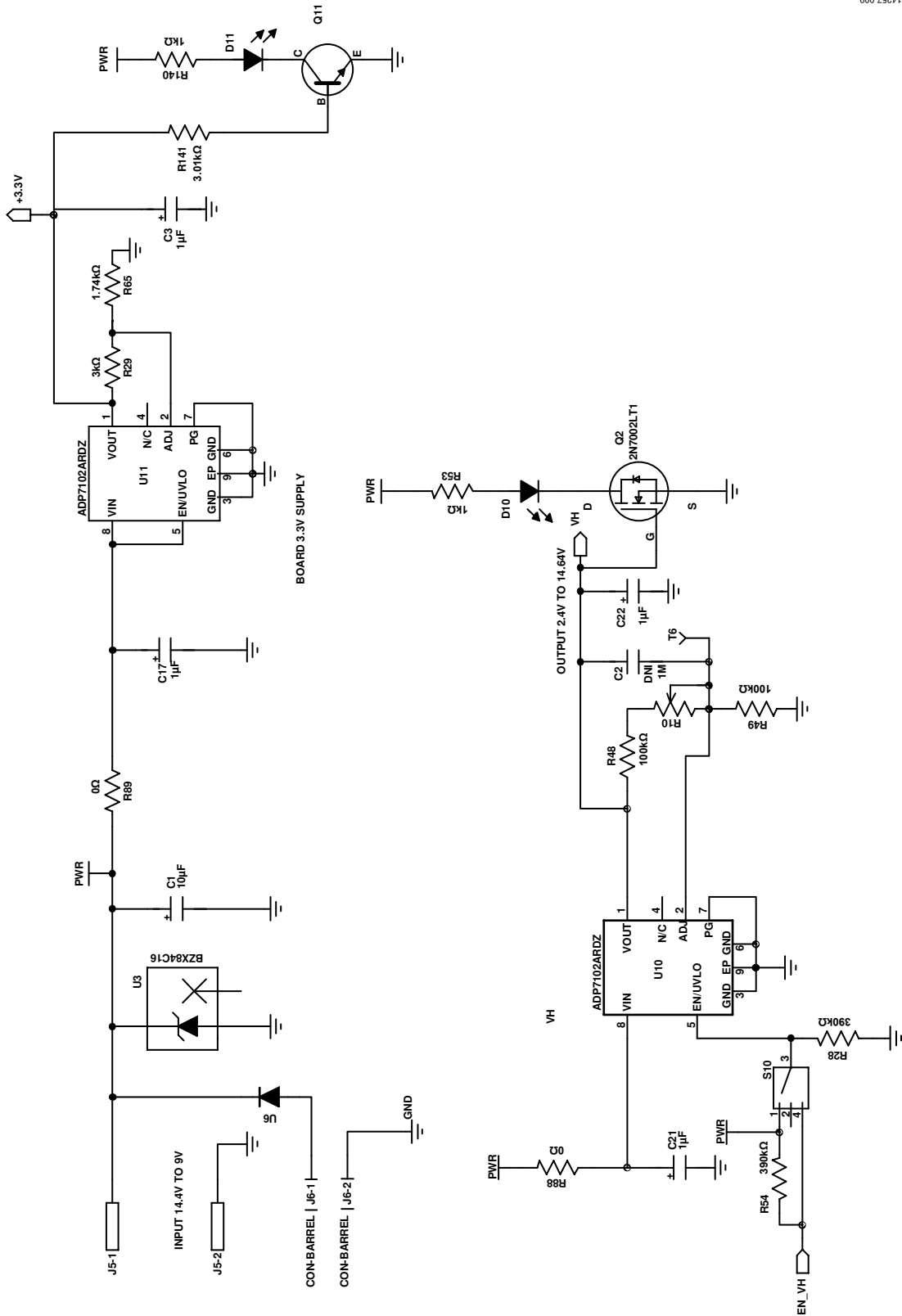

Figure 14. ADM1260 Evaluation Board Schematic, Page 2

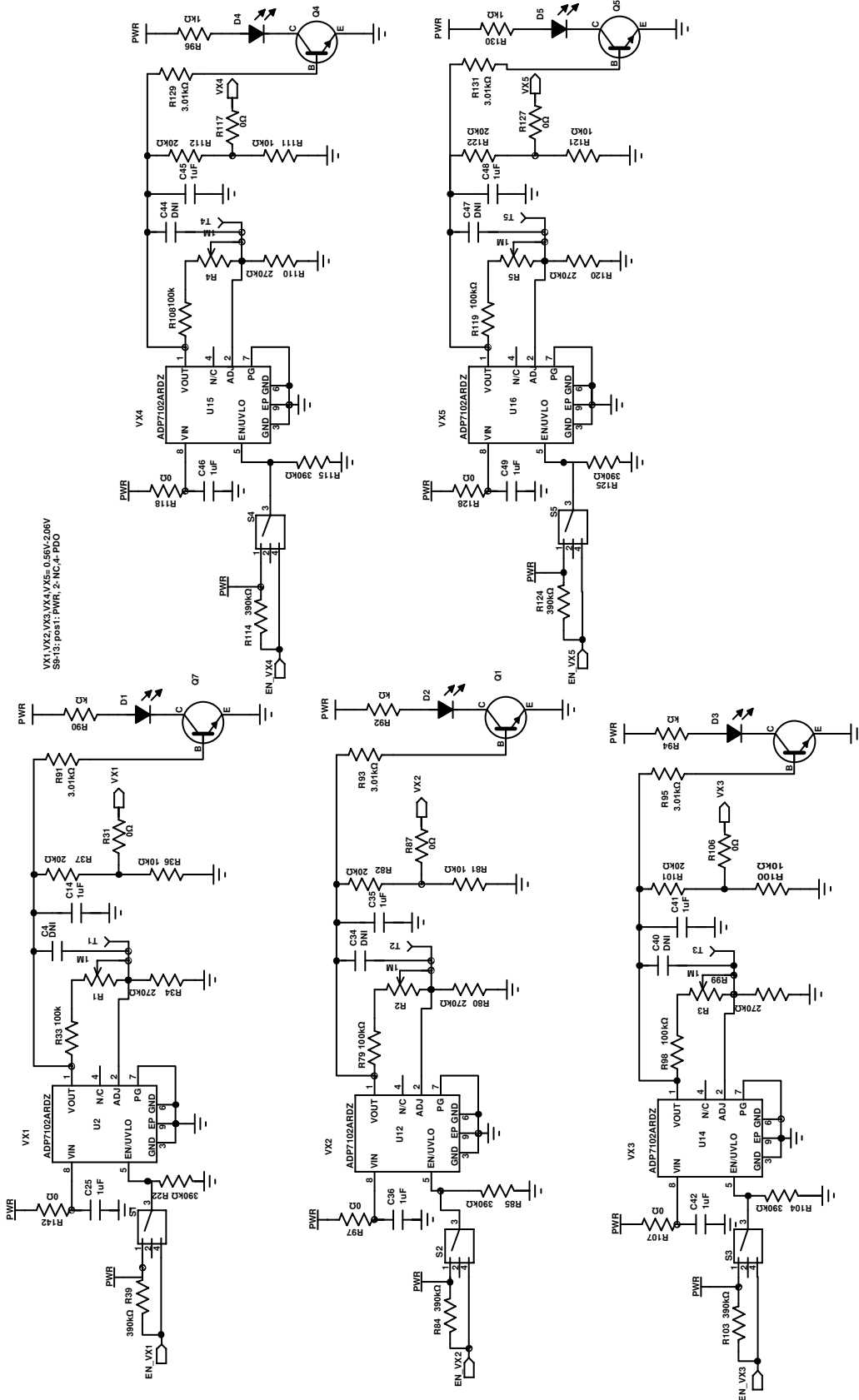

Figure 15. ADM1260 Evaluation Board Schematic, Page 3

14257-011

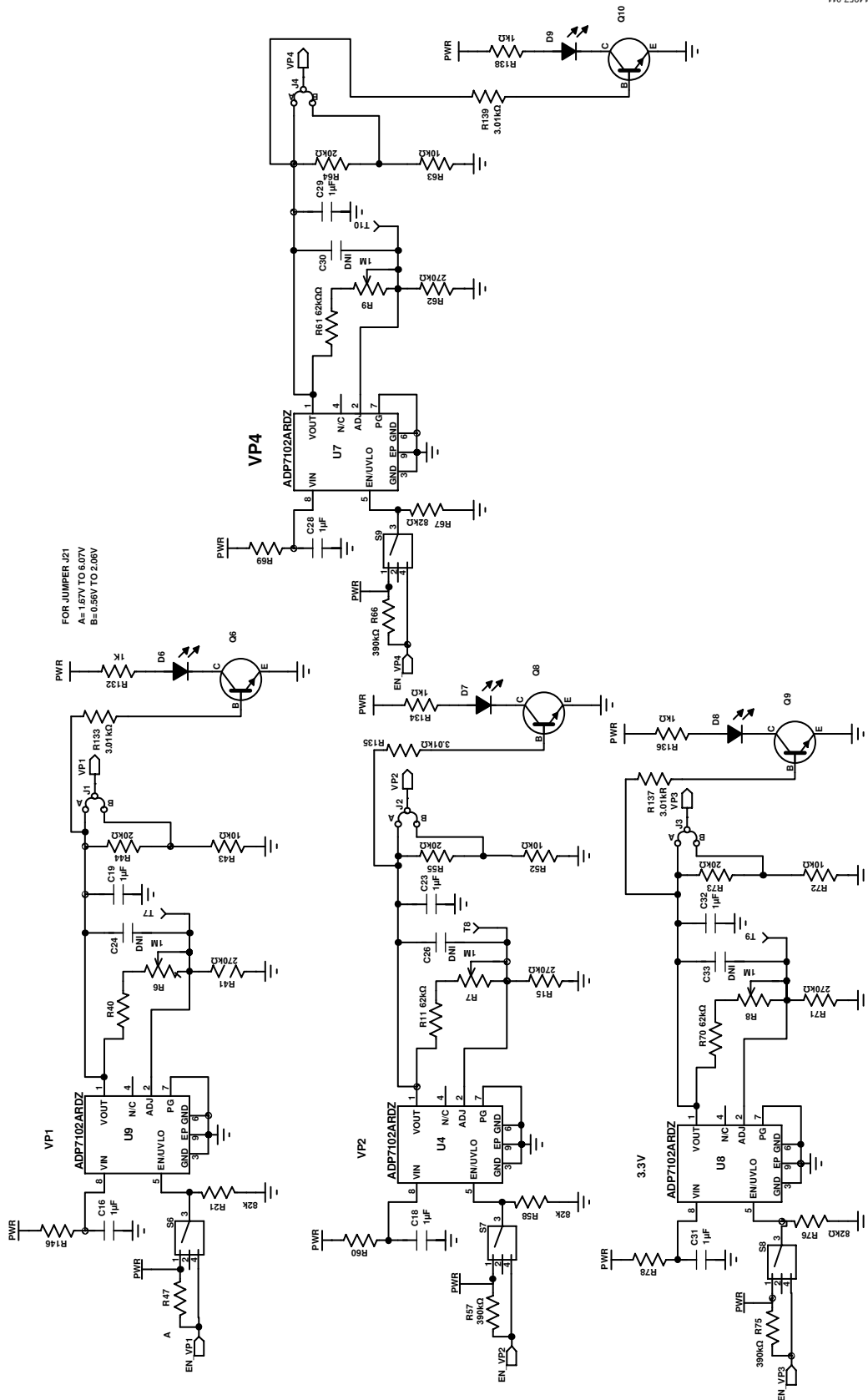

Figure 16. ADM1260 Evaluation Board Schematic, Page 4

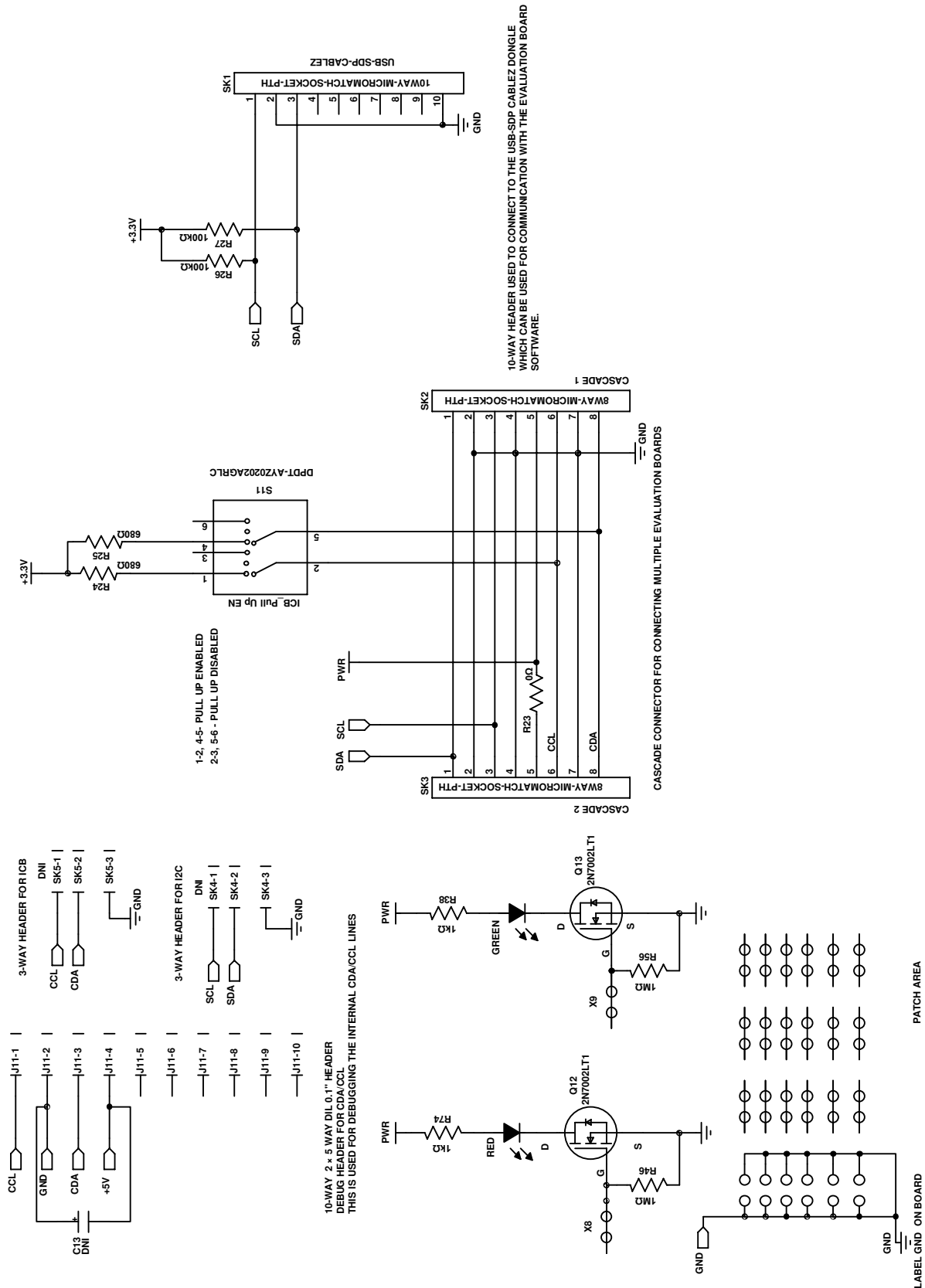

Figure 17. ADM1260 Evaluation Board Schematic, Page 5

ORDERING INFORMATION

BILL OF MATERIALS

Table 9.

Reference Designator	Description	Manufacturer	Part Number	Stock Code
A0, A1	Switch, dip, raised actuators, four-way	Omron Electronic Components	A6S-4104-H	FEC 1960899
C1	Aluminium electrolytic capacitor, Cease C, 10 µF, 35 V	Panasonic		FEC 9697012
C2, C4, C14, C16, C18, C19, C23 to C26, C28 to C36, C40 to C42, C44 to C49	Capacitors, MLCC, X7R, 1 µF, 16 V, 0603	AVX	0603YC105KAT2A	FEC 1658870
C3, C13, C17, C21, C22	Capacitors, MLCC, X5R, 1 µF, 25 V, 0603	AVX	06033D105KAT2A	FEC 1658868
C5 to C8, C10, C43	SMD capacitors, 220 pF	Phycomp	2238 867 15221	FEC 430948
C9, C11, C15	16 V, SMD tantalum capacitors, 10 µF	AVX	TAJB106K016R	FEC 498737
C20, C27	Capacitors, MLCC, X7R, 100 nF, 25 V, 0603	AVX	06033C104JAT2A	FEC 1740614RL
D1 to D11	Green, 0805, chip LEDs	Kingbright	KP-2012SGC	FEC 1318243
J1 to J4	3-pin, 0.1" pitch headers and shorting shunt inserted in Position H	Harwin	M20-9990346 and M7566-05	FEC 1022249 and 150-411
J5	20-pin (2 × 10) 0.1" pitch header		M20-9971046	FEC 102-2229
Q1, Q3 to Q11	General purpose NPD, SMD transistors	NXP	BC850C	FEC 1081241
Q2, Q12, Q13	N-channel, enhancement mode, MOSFETs	Fairchild	NDS7002A	FEC 984-5437
R1 to R10	3/8" square (10 mm), single-turn potentiometer, 1 MΩ resistors	Vishay	63M-T607-105	FEC 9608290
R11, R40, R61, R70	Resistors, 62 kΩ, 0.063 W, 1%, 0603	Multicomp	MC0063W0603162K	FEC 9331417
R12 to R14, R16	Resistors, 0805, 49.9 kΩ, 1%	Vishay Dale	CRCW080549K9FKEA	FEC 1469934
R15, R34, R41, R62, R71, R80, R99, R110, R120	Resistors, 270 kΩ, 0.063 W, 1%, 0603	Multicomp	MC0063W06031270K	FEC 9330941
R17, R19, R36, R43, R52, R63, R72, R81, R100, R111, R121	Resistors, 10 kΩ, 0.063 W, 1%, 0603	Multicomp	MC0063W0603110K	FEC 9330399
R18, R20	Resistors, 12 kΩ, 0.1 W, 1%, 0805	Multicomp	MC01W0805112K	FEC 9332502
R21, R22, R58, R67, R76, R85, R104, R115, R125	Resistors, 82 kΩ, 0.063 W, 1%, 0603	Multicomp	MC0063W0603182K	FEC 9331573
R23	Resistor, RC11, 0805, 0 Ω	Phycomp	232273091002	FEC 9233750RL
R24, R25	Resistors, 680 Ω, 0.063 W, 1%, 0603	Multicomp	MC0063W06031680R	FEC 9331441
R26, R27	Resistors, 0603, 100 kΩ	Vishay Draloric	CRCW0603100KFKEA	FEC 1469649
R28, R39, R47, R54, R57, R66, R75, R84, R103, R114, R124	Resistors, 390 kΩ, 0.063 W, 1%, 0603	Multicomp	MC0063W06031390K	FEC 9331166
R23	Resistors, 3 kΩ, 0.1 W, 1%, 0805	Multicomp	MC01W080513K	FEC 9332995
R31, R60, R63, R78, R87 to R89, R97, R106, R107, R117, R118, R127, R128, R142, R146	Resistors, 0603, 1%, 0 Ω	Multicomp	MC0063W06030R	FEC 9331662
R33, R48, R49, R79, R98, R108, R119	Resistors, 100 kΩ, 0.063 W, 1%, 0603	Multicomp	MC0063W06031100K	FEC 9330402
R37, R44, R55, R64, R73, R82, R101, R112	Resistors, 20 kΩ, 0.063 W, 1%, 0603	Multicomp	MC0063W0603120K	FEC 9330771
R38, R53, R74	Resistors, 1 kΩ, 0.063 W, 1%, 0603	Multicomp	MC0063W060311K	FEC 9330380
J5-1	Red, 4 mm, banana socket	Deltron	571-0500	FEC 150-039
J5-2	Black, 4 mm, banana socket	Deltron	571-0100	FEC 150-040
J6	2.1 mm, dc barrel power connector	Farnell		FEC 224-959
J11	Header, shrouded, 10-way	Molex	70246-1004	FEC 1392408
J40, J41	Headers, one row, 10-way	Tyco Electronics	1-826629-0	FEC 3418376
R46, R56	Resistors, 1 MΩ, 0.063 W, 1%, 0603	Multicomp	MC0063W060311M	FEC 9330410
R65	Resistor, 1.74 kΩ, 0.063 W, 1%, 0603	Multicomp	MC0063W060311K74	FEC 1170810
R83, R143 to R145	Resistors, 150 kΩ, 0.1 W, 1%, 0805	Multicomp	MC01W08051150K	FEC 9332626

Reference Designator	Description	Manufacturer	Part Number	Stock Code
R30, R32, R34, R36, R130, R132, R134, R136, R138, R140	Resistors, RC22H, 0603, 1 k Ω	Phycomp	232270461002	FEC 9238484
R31, R33, R35, R129, R131, R133, R135, R137, R139, R141	Resistors, 0603, 3k01, 1%	Vishay Dale	CRCW06033K01FKEA	FEC 1469791
S1 to S10	SP3T slide switches	ALPS	STSSS9131	FEC 1123876
T1 to T10	Headers, one-way, one row	FCI	68000-101HLF	FEC 1835272

I²C refers to a communications protocol originally developed by Philips Semiconductors (now NXP Semiconductors).



ESD Caution

ESD (electrostatic discharge) sensitive device. Charged devices and circuit boards can discharge without detection. Although this product features patented or proprietary protection circuitry, damage may occur on devices subjected to high energy ESD. Therefore, proper ESD precautions should be taken to avoid performance degradation or loss of functionality.

Legal Terms and Conditions

By using the evaluation board discussed herein (together with any tools, components documentation or support materials, the "Evaluation Board"), you are agreeing to be bound by the terms and conditions set forth below ("Agreement") unless you have purchased the Evaluation Board, in which case the Analog Devices Standard Terms and Conditions of Sale shall govern. Do not use the Evaluation Board until you have read and agreed to the Agreement. Your use of the Evaluation Board shall signify your acceptance of the Agreement. This Agreement is made by and between you ("Customer") and Analog Devices, Inc. ("ADI"), with its principal place of business at One Technology Way, Norwood, MA 02062, USA. Subject to the terms and conditions of the Agreement, ADI hereby grants to Customer a free, limited, personal, temporary, non-exclusive, non-sublicensable, non-transferable license to use the Evaluation Board FOR EVALUATION PURPOSES ONLY. Customer understands and agrees that the Evaluation Board is provided for the sole and exclusive purpose referenced above, and agrees not to use the Evaluation Board for any other purpose. Furthermore, the license granted is expressly made subject to the following additional limitations: Customer shall not (i) rent, lease, display, sell, transfer, assign, sublicense, or distribute the Evaluation Board; and (ii) permit any Third Party to access the Evaluation Board. As used herein, the term "Third Party" includes any entity other than ADI, Customer, their employees, affiliates and in-house consultants. The Evaluation Board is NOT sold to Customer; all rights not expressly granted herein, including ownership of the Evaluation Board, are reserved by ADI. CONFIDENTIALITY. This Agreement and the Evaluation Board shall all be considered the confidential and proprietary information of ADI. Customer may not disclose or transfer any portion of the Evaluation Board to any other party for any reason. Upon discontinuation of use of the Evaluation Board or termination of this Agreement, Customer agrees to promptly return the Evaluation Board to ADI. ADDITIONAL RESTRICTIONS. Customer may not disassemble, decompile or reverse engineer chips on the Evaluation Board. Customer shall inform ADI of any occurred damages or any modifications or alterations it makes to the Evaluation Board, including but not limited to soldering or any other activity that affects the material content of the Evaluation Board. Modifications to the Evaluation Board must comply with applicable law, including but not limited to the RoHS Directive. TERMINATION. ADI may terminate this Agreement at any time upon giving written notice to Customer. Customer agrees to return to ADI the Evaluation Board at that time. LIMITATION OF LIABILITY. THE EVALUATION BOARD PROVIDED HEREUNDER IS PROVIDED "AS IS" AND ADI MAKES NO WARRANTIES OR REPRESENTATIONS OF ANY KIND WITH RESPECT TO IT. ADI SPECIFICALLY DISCLAIMS ANY REPRESENTATIONS, ENDORSEMENTS, GUARANTEES, OR WARRANTIES, EXPRESS OR IMPLIED, RELATED TO THE EVALUATION BOARD INCLUDING, BUT NOT LIMITED TO, THE IMPLIED WARRANTY OF MERCHANTABILITY, TITLE, FITNESS FOR A PARTICULAR PURPOSE OR NON-INFRINGEMENT OF INTELLECTUAL PROPERTY RIGHTS. IN NO EVENT WILL ADI AND ITS LICENSORS BE LIABLE FOR ANY INCIDENTAL, SPECIAL, INDIRECT, OR CONSEQUENTIAL DAMAGES RESULTING FROM CUSTOMER'S POSSESSION OR USE OF THE EVALUATION BOARD, INCLUDING BUT NOT LIMITED TO LOST PROFITS, DELAY COSTS, LABOR COSTS OR LOSS OF GOODWILL. ADI'S TOTAL LIABILITY FROM ANY AND ALL CAUSES SHALL BE LIMITED TO THE AMOUNT OF ONE HUNDRED US DOLLARS (\$100.00). EXPORT. Customer agrees that it will not directly or indirectly export the Evaluation Board to another country, and that it will comply with all applicable United States federal laws and regulations relating to exports. GOVERNING LAW. This Agreement shall be governed by and construed in accordance with the substantive laws of the Commonwealth of Massachusetts (excluding conflict of law rules). Any legal action regarding this Agreement will be heard in the state or federal courts having jurisdiction in Suffolk County, Massachusetts, and Customer hereby submits to the personal jurisdiction and venue of such courts. The United Nations Convention on Contracts for the International Sale of Goods shall not apply to this Agreement and is expressly disclaimed.