

GlobTek, Inc. www.globtek.com 186 Veterans Drive, Northvale, NJ 07647 Tel. (201) 784-1000 Fax (201) 784-0111	Drawing Title: Lithium Ion Prismatic Battery Pack with Protection circuit. Cell Type: 18650; Pack Rating: 3.7V at 3.5Ahr. Pack Configuration: 1 Cell in Series and 1 Cell in Parallel; Pack Dimension: 18.6mm x 18.6mm x 70.3mm. Output Configuration: (2) UL3293 x 22awg x Black: 38mm; Red: 44.5mm x Stripped & tinned Wires. Outer Configuration: Shrink Wrap.	
	Model No. Battery Li-Ion Cylindrical	
	Part No./Ordering No. BL3500C1865001S1PCBT	Rev A

In Addition to GlobTek Inc.'s renewed ISO9001:2015 - Quality Management System Certification, GlobTek Inc. is now certified to:

ISO13485:2016 - Medical Devices Quality Management System Certification
ISO14001:2015 - Environmental Management System Certification

ISO Certificates are available online at <https://www.globtek.com/iso-certificates/>

By customer signing or accepting this document, they agree to acknowledge, constantly monitor, and accept the Guidelines and cautions, Safety Notes, and Safety Precautions published on GlobTek's website <https://www.globtek.com/safety-cautions/>

GlobTek offers a 5-year warranty on workmanship and electrical components assembly on all new battery pack products excluding the battery cells themselves which are covered by the Manufacturer's original warranty at their published warranty period. Please refer to the manufacturer's manufacturer's warranty policy for cells. For GlobTek brand cells, GlobTek provides a 12-month warranty for Li-Ion batteries. The warranty period is based upon the expectation that the battery will deliver 80% of its initial capacity after 300 cycles at low to moderate power loads. High power loads may cause a battery to reach 80% of initial capacity in less than the 12-month warranty period. Li-Ion batteries will continue to operate below the 80% capacity threshold; however, the capacity (run time) delivered between charges will continue to decrease.

The purchaser of GlobTek battery pack products (Customer) agrees that they are a "Sophisticated user" who understands battery technology and that it is their sole responsibility to determine suitability of the product described for their application and to take precautions for protection against any hazards attendant to the handling and use of the product. GlobTek products are only designed for professional use and integration by companies into their products and may not be used by consumers directly. GlobTek provides batteries and battery packs as a component of an end system.

The acceptance of GlobTek specifications, the information on this page and use of the product(s) described in this or other GlobTek documents indicate that the product was qualified for use (tested and/or sample waiver signed), and the acceptance and binding of the customer to GlobTek TERMS AND CONDITIONS (attached to the end of this document), which supersede all other agreements, terms and conditions <https://www.globtek.com/terms-and-conditions/>

Lithium Ion batteries are inherently dangerous. Continuous usage or charging without allowing the battery to discharge is a hazard.

FIRE HAZARD: This like all Li-Ion battery packs must be regularly discharged and charged. it is not recommended to be kept on permanent full charge and in a full state of charge.

Footnote:

GlobTek Inc. will not be liable for the safety and performance of these power supplies/battery packs if unauthorized access and repair occurs. End user should consult applicable UL, CSA or EN standards for proper installation instruction.

Limitation of Use:

GlobTek products are intended for use with commercial, medical, and/or industrial equipment only. GlobTek product are not authorized for use as mission critical components in life support hazardous environment, nuclear or aircraft applications without prior written approval from the CEO of GlobTek Inc. Contents of this document are subject to change without prior notice.

Customer Approval of Specification:

Please approve, sign and send back to GlobTek so we can complete order processing.
A delay in receipt of this form will delay delivery schedule.

Company Name:	Customer P/N:
Quote Number:	Date:
Authorized Representative Name:	Authorized Representative Signature:

GloTek, Inc. www.globtek.com 186 Veterans Drive, Northvale, NJ 07647 Tel. (201) 784-1000 Fax (201) 784-0111	Drawing Title: Lithium Ion Prismatic Battery Pack with Protection circuit. Cell Type: 18650; Pack Rating: 3.7V at 3.5Ahr. Pack Configuration: 1 Cell in Series and 1 Cell in Parallel; Pack Dimension: 18.6mm x 18.6mm x 70.3mm. Output Configuration: (2) UL3293 x 22awg x Black: 38mm; Red: 44.5mm x Stripped & tinned Wires. Outer Configuration: Shrink Wrap.	
	Model No. Battery Li-Ion Cylindrical	
	Part No./Ordering No. BL3500C1865001S1PCBT	Rev A

REVISION HISTORY

REV	DESCRIPTION	SUB	DATE	APPROVED
A	Initial release	DR	04/08/2022	DAVID

BATTERY PACK INFORMATION

TYPE	Battery Cylindrical Can
TECHNOLOGY	Battery Li-Ion
PACK ID	None
PROTECTION MODULE (PCM):	
PACK NOMINAL VOLTAGE (V)	3.60
PACK RATED CAPACITY (mAh)	3350.00
WATT-HOUR RATING (Wh)	12.06
INGRESS PROTECTION:	IPx0
LABEL SPECS	label BL3500C1865001S1PCBT,L-1656
SPECIAL BARCODE LABEL MATERIAL	No
USER MANUAL	
PACK SPEC	packing for battery BL3500C1865001S1PCCTJS2

GlobTek, Inc.
www.globtek.com
186 Veterans Drive,
Northvale, NJ 07647
Tel. (201) 784-1000
Fax (201) 784-0111

Drawing Title: Lithium Ion Prismatic Battery Pack with Protection circuit. Cell Type: 18650; Pack Rating: 3.7V at 3.5Ahr. Pack Configuration: 1 Cell in Series and 1 Cell in Parallel; Pack Dimension: 18.6mm x 18.6mm x 70.3mm. Output Configuration: (2) UL3293 x 22awg x Black: 38mm; Red: 44.5mm x Stripped & tinned Wires. Outer Configuration: Shrink Wrap.

Model No. Battery Li-Ion Cylindrical

Part No./Ordering No. BL3500C1865001S1PCBT

Rev A

Notes/Modifications/Customizations (notes in this section supersede the values shown in the standard spec)

DIMENSIONS ARE IN MM UNLESS SPECIFIED OTHERWISE

Mechanical configuration for this item as below. Lithium Ion battery with button top for applications with removeable battery packs:

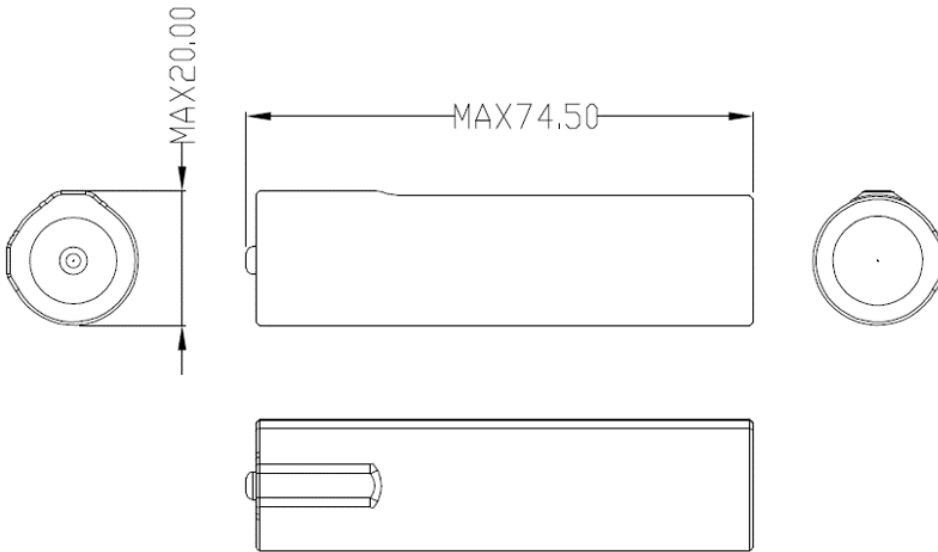

GloTek, Inc. www.globtek.com 186 Veterans Drive, Northvale, NJ 07647 Tel. (201) 784-1000 Fax (201) 784-0111	Drawing Title: Lithium Ion Prismatic Battery Pack with Protection circuit. Cell Type: 18650; Pack Rating: 3.7V at 3.5Ahr. Pack Configuration: 1 Cell in Series and 1 Cell in Parallel; Pack Dimension: 18.6mm x 18.6mm x 70.3mm. Output Configuration: (2) UL3293 x 22awg x Black: 38mm; Red: 44.5mm x Stripped & tinned Wires. Outer Configuration: Shrink Wrap.	
	Model No. Battery Li-Ion Cylindrical	
	Part No./Ordering No. BL3500C1865001S1PCBT	Rev A

ELECTRICAL SPECIFICATIONS

GENERAL SPECIFICATION:

BATTERY WITH SAFETY CIRCUIT AND PLASTIC HOUSING

CELL:	LR1865HB
PCM:	GLOBTEK STANDARD+PTC:JK-P260 2.6A 16V
NTC:	N/A
ID:	N/A
CONFIGURATION:	1S1P
WEIGHT:	APROX 45 G

2.ELECTRICAL SPECIFICATION FOR PACK:

RATED CAPACITY:	3350 mAh
NOMINAL VOLTAGE:	3.6V
WATT-HOUR RATING:	12.06Wh
CHARGING METHOD:	CONSTANT CURRENT + CONSTANT VOLTAGE
MAX. CHARGE VOLTAGE [V]:	4.2V Max (4.1V Max recommended for maximizing life and health of battery cells and preventing premature failure)

CHARGE CURRENT:	0.3C recommended, 0.5C Maximum. For a deeply discharged cell with a voltage of 3.0V or less, a pre-charge current equal to or less than 0.1C is highly recommended.
-----------------	---

PROPRIETARY INFORMATION

GlobTek, Inc. www.globtek.com 186 Veterans Drive, Northvale, NJ 07647 Tel. (201) 784-1000 Fax (201) 784-0111	Drawing Title: Lithium Ion Prismatic Battery Pack with Protection circuit. Cell Type: 18650; Pack Rating: 3.7V at 3.5Ahr. Pack Configuration: 1 Cell in Series and 1 Cell in Parallel; Pack Dimension: 18.6mm x 18.6mm x 70.3mm. Output Configuration: (2) UL3293 x 22awg x Black: 38mm; Red: 44.5mm x Stripped & tinned Wires. Outer Configuration: Shrink Wrap.	
	Model No. Battery Li-Ion Cylindrical	
	Part No./Ordering No. BL3500C1865001S1PCBT	Rev A

RECOMMENDED CHARGE CUT OFF:

When charge rate falls to 10% of bulk charge or by secondary charge termination such as a Timer as specified by customer which best suits the application and charging method to be used.

MAX. CONTINUOUS DISCHARGE CURRENT:

2A

RECOMMENDED DISCHARGE CUT OFF:

3.0v. GlobTek recommends a customer system level permanent fail protection if the cell voltage drops to 2.50V

INTERNAL IMPEDANCE:

≤220 MΩ

EXP. CYCLE LIFE:

>500 CYCLES > 70% OF INITIAL CAP. (0,5C/0,5C)

GlobTek, Inc. www.globtek.com 186 Veterans Drive, Northvale, NJ 07647 Tel. (201) 784-1000 Fax (201) 784-0111	Drawing Title: Lithium Ion Prismatic Battery Pack with Protection circuit. Cell Type: 18650; Pack Rating: 3.7V at 3.5Ahr. Pack Configuration: 1 Cell in Series and 1 Cell in Parallel; Pack Dimension: 18.6mm x 18.6mm x 70.3mm. Output Configuration: (2) UL3293 x 22awg x Black: 38mm; Red: 44.5mm x Stripped & tinned Wires. Outer Configuration: Shrink Wrap.	
	Model No. Battery Li-Ion Cylindrical	
	Part No./Ordering No. BL3500C1865001S1PCBT	Rev A

CELL PROTECTION:	
OVER CHARGE DETECTION:	4.25 ±0.03V
	(0.8 TO 1.2 SEC. DELAY, RESUME 4.19±0.03V)
OVER DISCHARGE DETECTION:	2.80 ±0.05V
	(130 to 160msec. DELAY, RESUME 3.0±0.05V)
OVER CURRENT DETECTION:	4.0A to 7.0A (8 to 15msec. DELAY)
PRECONDITIONED AT THE FACTORY	YES
3. AMBIENT CONDITIONS	
TEMPERATURE RANGE:	
CHARGE:	0 TO +45°C
DISCHARGE:	-10 TO +60°C
CHARGE RETENTION/STORAGE [%]:	1 YEAR AT -20 TO +20°C >80%
	3 MONTHS AT -20 TO +45°C >80%
	1 MONTH AT -20 To +60°C >80%
HUMIDITY:	60 ±25%RH
4. ENVIORMENTAL AND SAFETY	
Please review quarterly and follow HANDLING AND SAFETY PRECAUTIONS FOR Lilon & LiPolymer.	

GlobTek, Inc. www.globtek.com 186 Veterans Drive, Northvale, NJ 07647 Tel. (201) 784-1000 Fax (201) 784-0111	Drawing Title: Lithium Ion Prismatic Battery Pack with Protection circuit. Cell Type: 18650; Pack Rating: 3.7V at 3.5Ahr. Pack Configuration: 1 Cell in Series and 1 Cell in Parallel; Pack Dimension: 18.6mm x 18.6mm x 70.3mm. Output Configuration: (2) UL3293 x 22awg x Black: 38mm; Red: 44.5mm x Stripped & tinned Wires. Outer Configuration: Shrink Wrap.	
	Model No. Battery Li-Ion Cylindrical	
	Part No./Ordering No. BL3500C1865001S1PCBT	Rev A

5. CELL REGULATORY APPROVALS:

UL: UL1642

IEC 61960 Cell designation and marking:

11NR19/66

TO ADDRESS SYSTEM-LEVEL EMI CONCERNS, FERRITE CHOKES/BEADS MAY BE ADDED/REVISED UPON REQUEST. A SAMPLE KIT OF GLOBTEK'S STANDARD FERRITES IS AVAILABLE UNDER GLOBTEK P/N: EMI-MITIGATION-KIT1









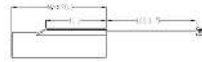

FOR ADDITIONAL INFORMATION, PLEASE READ OUR WHITE PAPER AT: <https://r.globtek.info/3QeaqtD>

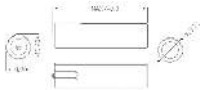
INGRESS PROTECTION: IPx0

GlobTek, Inc. www.globtek.com 186 Veterans Drive, Northvale, NJ 07647 Tel. (201) 784-1000 Fax (201) 784-0111	Drawing Title: Lithium Ion Prismatic Battery Pack with Protection circuit. Cell Type: 18650; Pack Rating: 3.7V at 3.5Ahr. Pack Configuration: 1 Cell in Series and 1 Cell in Parallel; Pack Dimension: 18.6mm x 18.6mm x 70.3mm. Output Configuration: (2) UL3293 x 22awg x Black: 38mm; Red: 44.5mm x Stripped & tinned Wires. Outer Configuration: Shrink Wrap.	
	Model No. Battery Li-Ion Cylindrical	Part No./Ordering No. BL3500C1865001S1PCBT

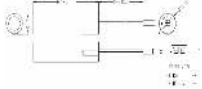
Rev A

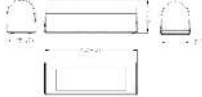
Mechanical drawing

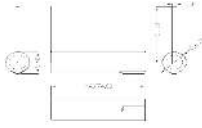
Model	Image	Mechanical Drawing	Type
BL3500C1865001S1PCMK			1S1P 18 CONNE
BL3500C1865001S1PCMK***			1S1P 18
BL3500C1865001S1P*S****			1S1P 18
BL3500C1865001S1P*C****			1S1P 18 CUSTO
BL3500C1865001S1P*P****			1S1P 18 be custo
BL3500C1865001S1P*WN***			1S1P 18

GlobTek, Inc.
www.globtek.com
186 Veterans Drive,
Northvale, NJ 07647
Tel. (201) 784-1000
Fax (201) 784-0111

Drawing Title: Lithium Ion Prismatic Battery Pack with Protection circuit. Cell Type: 18650; Pack Rating: 3.7V at 3.5Ahr. Pack Configuration: 1 Cell in Series and 1 Cell in Parallel; Pack Dimension: 18.6mm x 18.6mm x 70.3mm. Output Configuration: (2) UL3293 x 22awg x Black: 38mm; Red: 44.5mm x Stripped & tinned Wires. Outer Configuration: Shrink Wrap.

Model No. Battery Li-Ion Cylindrical

Part No./Ordering No. BL3500C1865001S1PCBT

Rev A

OUTPUT CORD AND CONNECTOR: None/C0745

ACTUAL CONNECTORS, OVERMOLDS, FERRITES MAY VARY SLIGHTLY FROM THE PICTURE BELOW

CABLE TYPE N/A

CABLE LENGTH (mm) N/A

CABLE TOLERANCE (mm) N/A

WIRE GAUGE (AWG) N/A

CONDUCTORS

HANK DIMENSION (mm) N/A

CABLE / CONNECTOR OVERMOLD COLOR N/A

PLUG TYPE None

STANDARD CONNECTOR HOUSINGS

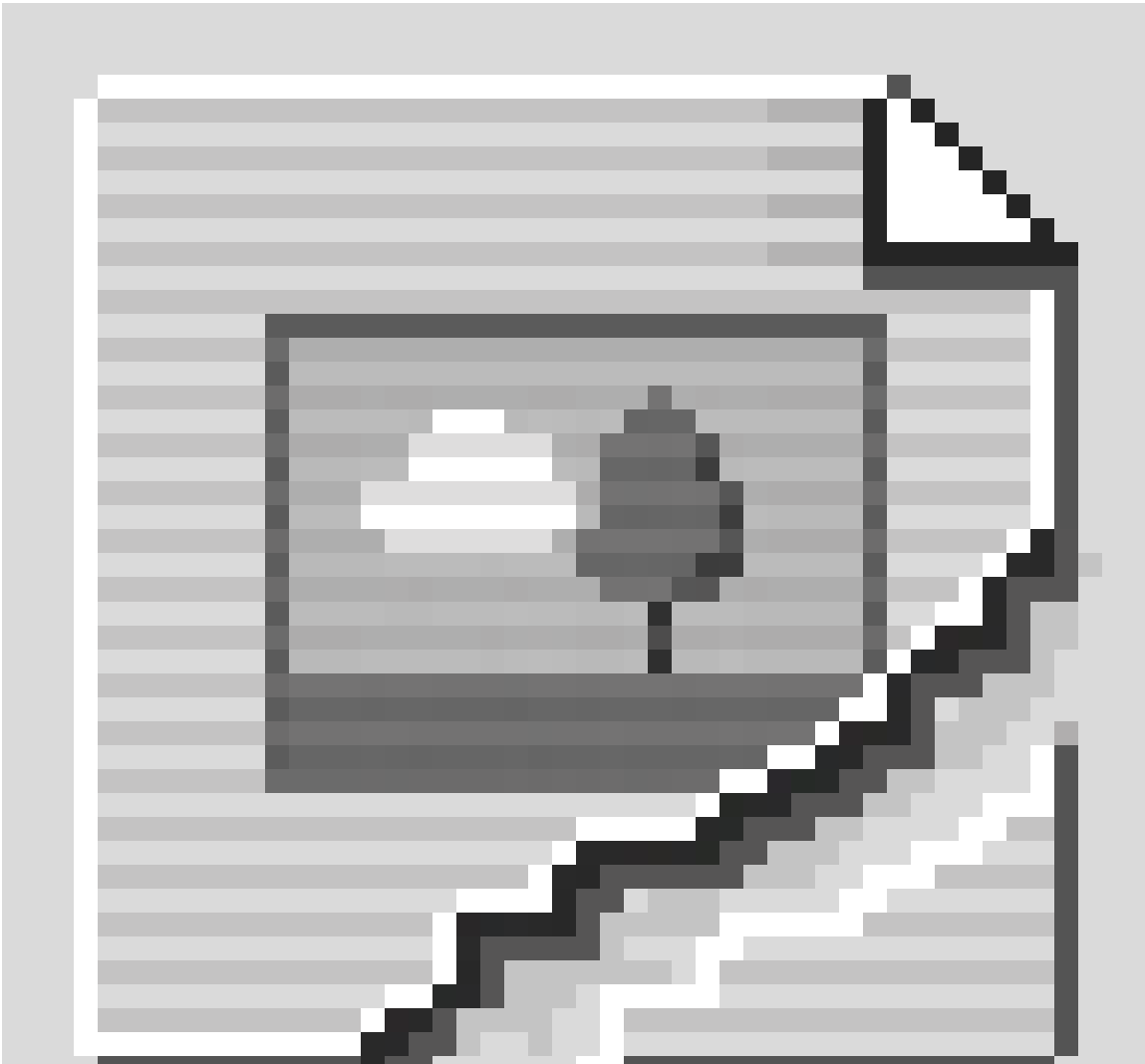

PROPRIETARY INFORMATION

PROPRIETARY OF GLOBTEK, INC. ANY REPRODUCTION, DISCLOSURE OR USE OF THIS DRAWING, IN WHOLE OR IN PART, IS HEREBY PROHIBITED EXCEPT AS SPECIFIED IN WRITING BY GLOBTEK, INC. © GlobTek, Inc. 2022 - 2023

GlobTek, Inc. www.globtek.com 186 Veterans Drive, Northvale, NJ 07647 Tel. (201) 784-1000 Fax (201) 784-0111	Drawing Title: Lithium Ion Prismatic Battery Pack with Protection circuit. Cell Type: 18650; Pack Rating: 3.7V at 3.5Ahr. Pack Configuration: 1 Cell in Series and 1 Cell in Parallel; Pack Dimension: 18.6mm x 18.6mm x 70.3mm. Output Configuration: (2) UL3293 x 22awg x Black: 38mm; Red: 44.5mm x Stripped & tinned Wires. Outer Configuration: Shrink Wrap.	
	Model No. Battery Li-Ion Cylindrical	
	Part No./Ordering No. BL3500C1865001S1PCBT	Rev A

OVER MOLD ORIENTATION

N/A

ADDITIONAL OUTPUT PLUG OPTIONS ARE AVAILABLE AT <https://www.globtek.com/connectors/>
STANDARD PLUGS AND CONNECTORS CAN BE SEEN ONLINE AT <https://www.globtek.com/connectors/>
CALCULATE VOLTAGE REGULATION/DROP WITH OUR ONLINE CALCULATOR: <https://en.globtek.com/output-cable-regulation-calculator/>

GlobTek, Inc. www.globtek.com 186 Veterans Drive, Northvale, NJ 07647 Tel. (201) 784-1000 Fax (201) 784-0111	Drawing Title: Lithium Ion Prismatic Battery Pack with Protection circuit. Cell Type: 18650; Pack Rating: 3.7V at 3.5Ahr. Pack Configuration: 1 Cell in Series and 1 Cell in Parallel; Pack Dimension: 18.6mm x 18.6mm x 70.3mm. Output Configuration: (2) UL3293 x 22awg x Black: 38mm; Red: 44.5mm x Stripped & tinned Wires. Outer Configuration: Shrink Wrap.
	Model No. Battery Li-Ion Cylindrical
Part No./Ordering No. BL3500C1865001S1PCBT	Rev A

LABEL:L-1656

LABEL P/N	label BL3500C1865001S1PCBT
MATERIAL	Flat Thermal Transfer, Imprintable, Polyester Label and/or Pad Printed and/or Molded, and/or Laser Engraved in the case
BACKGROUND COLOR	Black if housing is Black, White or Silver if housing is White or Gray.
TEXT COLOR	White or Silver if label is Black Background for Black housing. Black if label is White or Silver background and Housing is White or Gray.
SPECIAL BARCODE LABEL MATERIAL	No

Below is the minimum information which will appear on the label. NOTE: in the logo area additional/actual positioning of symbols and text is subjected to change as per agency updates/requirements or additional model approvals become available.
 Regulatory certifications/label markings may be in logo area on the label or molded into the case housing outside the label area.
 Information will be shown via label and/or pad printed and/or molded and/or laser engraved in the case. * Date code markings at GlobTek option

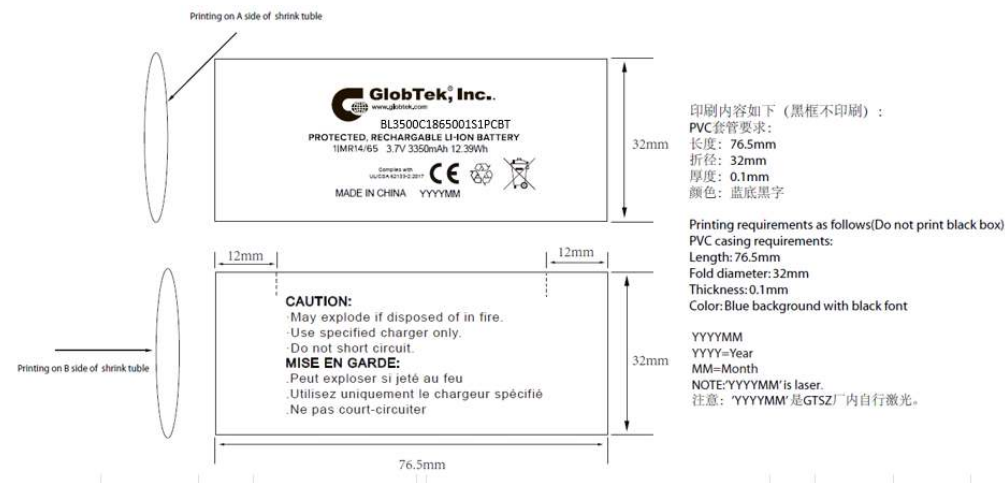

A=
 B=P/N: (料号) BL3500C1865001S1PCBT
 C=Model (型号) Battery Li-Ion Cylindrical
 E=Output (输出) Pack Nominal Voltage 3.60 (V), Pack Rated Capacity 3350.00 (mAh), Watt-Hour Rating 12.06 (Wh)

GlobTek, Inc. www.globtek.com 186 Veterans Drive, Northvale, NJ 07647 Tel. (201) 784-1000 Fax (201) 784-0111	Drawing Title: Lithium Ion Prismatic Battery Pack with Protection circuit. Cell Type: 18650; Pack Rating: 3.7V at 3.5Ahr. Pack Configuration: 1 Cell in Series and 1 Cell in Parallel; Pack Dimension: 18.6mm x 18.6mm x 70.3mm. Output Configuration: (2) UL3293 x 22awg x Black: 38mm; Red: 44.5mm x Stripped & tinned Wires. Outer Configuration: Shrink Wrap.	
	Model No. Battery Li-Ion Cylindrical	
	Part No./Ordering No. BL3500C1865001S1PCBT	Rev A

AGENCY ONLINE DOCUMENTS	http://www.globtek.info/certs/BL3500C1865001S1PCMK/
CE EC-Declaration for Medical	Contact GlobTek for more information
CE EC-Declaration for Industrial/Commercial/ITE	Contact GlobTek for more information
CE EC-Declaration for Household	Contact GlobTek for more information
UKCA-Declaration for Medical	Contact GlobTek for more information
UKCA-Declaration for Industrial/Commercial/ITE	Contact GlobTek for more information
UKCA-Declaration for Household	Contact GlobTek for more information
Morocco SDoC Declaration	https://globtek.secure.force.com/models/Morocco_SDoC_Declaration?id=a0O3a00000MnSxJEAV
RoHS/RoHS3 Declaration	https://www.globtek.com/pdf/rohs_cert/01t3a000005KryfAAC
REACH Declaration	https://www.globtek.com/pdf/iso_certificates/REACH.pdf
Conflict Minerals Declaration	https://www.globtek.com/pdf/conflict-minerals.pdf
Prop 65 Statement	https://en.globtek.com/prop-65-statement.pdf
IPXY rating is based on 3rd party testing and customers should check suitability and test system level IPXY rating before ordering.	

Regulatory Certifications/Label Markings

Below follows a link to the latest regulatory certifications and marks for this specific product. National standards as well as certification schemes are constantly changing and so is the set of certification marks and symbols applicable to this product. Various standards, marks and symbols, and certificates are subject to change at any time without notice.

Additional standards or unique country certifications are available upon request. Please contact Globtek to request a quotation.

LATEST PRODUCT/MODEL CERTIFICATIONS: <https://www.globtek.com/datasheet/w121546>

AGENCY ONLINE DOCUMENTS <http://www.globtek.info/certs/BL3500C1865001S1PCMK/>

GlobTek, Inc. www.globtek.com 186 Veterans Drive, Northvale, NJ 07647 Tel. (201) 784-1000 Fax (201) 784-0111	Drawing Title: Lithium Ion Prismatic Battery Pack with Protection circuit. Cell Type: 18650; Pack Rating: 3.7V at 3.5Ahr. Pack Configuration: 1 Cell in Series and 1 Cell in Parallel; Pack Dimension: 18.6mm x 18.6mm x 70.3mm. Output Configuration: (2) UL3293 x 22awg x Black: 38mm; Red: 44.5mm x Stripped & tinned Wires. Outer Configuration: Shrink Wrap.	
	Model No. Battery Li-Ion Cylindrical	
	Part No./Ordering No. BL3500C1865001S1PCBT	Rev A

PACKAGING

Packing Spec P/N	packing for battery BL3500C1865001S1PCCTJS2
Box Qty	128
Gift Box Size (mm)	32x40x92
Gift Box Color	White
Master Carton Size (mm)	165 x 335 x 375
Master Carton Cubic Volume (m ³)	0.02
Master GW (Kg)	kg
BLADES INCLUDED	:
BLADE/CORD INSTALLED	:
USER MANUAL*	
USER MANUAL WEB LINK	

* This specification sheet is considered the user manual for all applications. It is expected that the buyer of this product will use it to formulate their own user manual for their end product and a user manual specifically for the power adapter is not usually required. If a user manual is not specifically listed above then none will be provided with this unit.

GlobTek, Inc.
 www.globtek.com
 186 Veterans Drive,
 Northvale, NJ 07647
 Tel. (201) 784-1000
 Fax (201) 784-0111

Drawing Title: Lithium Ion Prismatic Battery Pack with Protection circuit. Cell Type: 18650; Pack Rating: 3.7V at 3.5Ahr. Pack Configuration: 1 Cell in Series and 1 Cell in Parallel; Pack Dimension: 18.6mm x 18.6mm x 70.3mm. Output Configuration: (2) UL3293 x 22awg x Black: 38mm; Red: 44.5mm x Stripped & tinned Wires. Outer Configuration: Shrink Wrap.

Model No. Battery Li-Ion Cylindrical

Part No./Ordering No. BL3500C1865001S1PCBT

Rev A

128 PCS/CARTON

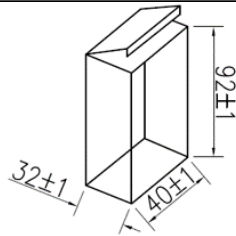
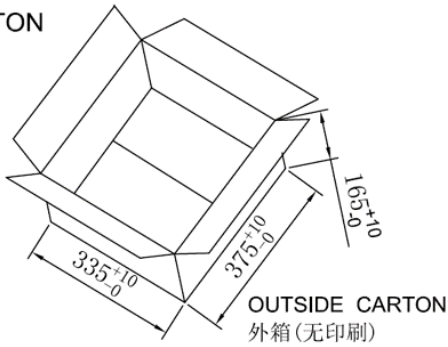

GIFT BOX

BUBBLE BAG

PARTITION 隔板

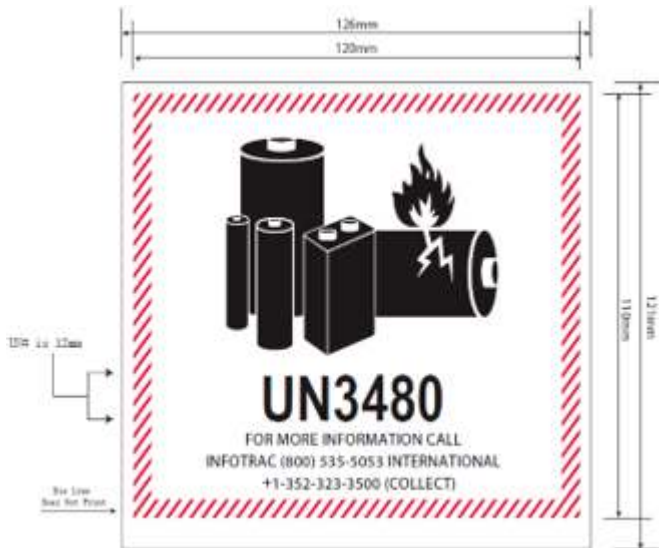

GlobTek, Inc. www.globtek.com 186 Veterans Drive, Northvale, NJ 07647 Tel. (201) 784-1000 Fax (201) 784-0111	Drawing Title: Lithium Ion Prismatic Battery Pack with Protection circuit. Cell Type: 18650; Pack Rating: 3.7V at 3.5Ahr. Pack Configuration: 1 Cell in Series and 1 Cell in Parallel; Pack Dimension: 18.6mm x 18.6mm x 70.3mm. Output Configuration: (2) UL3293 x 22awg x Black: 38mm; Red: 44.5mm x Stripped & tinned Wires. Outer Configuration: Shrink Wrap.	
	Model No. Battery Li-Ion Cylindrical	
	Part No./Ordering No. BL3500C1865001S1PCBT	Rev A

INSTRUCTIONS TO THE OEM SYSTEMS ENGINEER

It is the responsibility of the OEM systems engineer to provide the end system user instructions and warnings for the use of this product in the end system.

If an input cord is required for this product, AC Mains voltage should be provided to the power supply by a power supply cord approved to the national standards of the country in which it will be used.

This product is not designed to be repaired. No serviceable parts inside. A blown internal fuse is an indication of catastrophic failure of circuit component(s). If a Failure Analysis is required for a failed power supply/battery charger, please return the damaged unit to GlobTek for an accurate determination of the root cause of the failure.

EMC Compliance of the complete OEM product, including the GlobTek power supply/battery charger needs to be verified by the OEM systems engineer.

INSTRUCTION SHEET

GlobTek, Inc.
www.globtek.com
186 Veterans Drive,
Northvale, NJ 07647
Tel. (201) 784-1000
Fax (201) 784-0111

Drawing Title: Lithium Ion Prismatic Battery Pack with Protection circuit. Cell Type: 18650; Pack Rating: 3.7V at 3.5Ahr. Pack Configuration: 1 Cell in Series and 1 Cell in Parallel; Pack Dimension: 18.6mm x 18.6mm x 70.3mm. Output Configuration: (2) UL3293 x 22awg x Black: 38mm; Red: 44.5mm x Stripped & tinned Wires. Outer Configuration: Shrink Wrap.

Model No. Battery Li-Ion Cylindrical

Part No./Ordering No. BL3500C1865001S1PCBT

Rev A

