

# High Current Boost Regulator

## GENERAL DESCRIPTION

The ML4871 is a continuous conduction boost regulator designed for DC to DC conversion in multiple cell battery powered systems. Continuous conduction allows the regulator to maximize output current for a given inductor. The maximum switching frequency can exceed 200kHz, allowing the use of small, low cost inductors. The ML4871 is capable of start-up with input voltages as low as 1.8V and is available in 5V and 3.3V output versions with an output voltage accuracy of  $\pm 3\%$ .

An integrated synchronous rectifier eliminates the need for an external Schottky diode and provides a lower forward voltage drop, resulting in higher conversion efficiency. In addition, low quiescent battery current and variable frequency operation result in high efficiency even at light loads. The ML4871 requires only one inductor and two capacitors to build a very small regulator circuit capable of achieving conversion efficiencies approaching 90%.

The circuit also contains a  $\overline{\text{RESET}}$  output which goes low when the DETECT input drops below 1.25V.

## FEATURES

- Guaranteed full load start-up and operation at 1.8V Input
- Continuous conduction mode for high output current
- Very low supply current (20 $\mu$ A output referenced) for Micropower operation
- Pulse Frequency Modulation and Internal Synchronous Rectification for high efficiency
- Maximum switching frequency > 200kHz
- Minimum external components
- Low ON resistance internal switching FETs
- 5V and 3.3V output versions

## BLOCK DIAGRAM

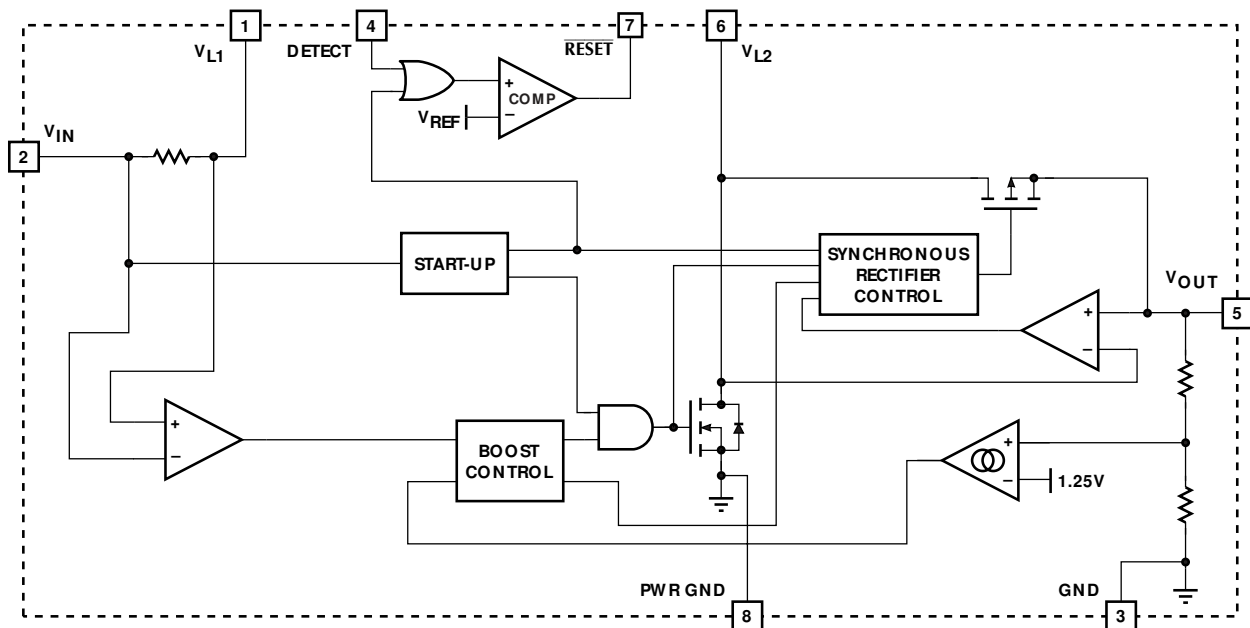

# ML4871

## PIN CONFIGURATION

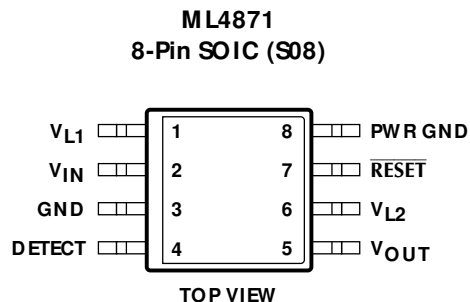

## PIN DESCRIPTION

NO.	NAME	FUNCTION	NO.	NAME	FUNCTION
1	V <sub>L1</sub>	Boost inductor connection	5	V <sub>OUT</sub>	Boost regulator output
2	V <sub>IN</sub>	Battery input voltage	6	V <sub>L2</sub>	Boost inductor connection
3	GND	Ground	7	$\overline{\text{RESET}}$	Output goes low when DETECT goes below 1.25V
4	DETECT	Pulling this pin below 1.25V causes the $\overline{\text{RESET}}$ pin to go low	8	PWR GND	Return for the NMOS output transistor

## ABSOLUTE MAXIMUM RATINGS

Absolute maximum ratings are those values beyond which the device could be permanently damaged. Absolute maximum ratings are stress ratings only and functional device operation is not implied.

$V_{OUT}$ .....	7V
Voltage on Any Other Pin ....	GND – 0.3V to $V_{OUT} + 0.3V$
Peak Switch Current ( $I_{PEAK}$ ) .....	2A
Average Switch Current ( $I_{AVG}$ ) .....	1A
Junction Temperature .....	150°C
Storage Temperature Range .....	–65°C to 150°C
Lead Temperature (Soldering 10 sec) .....	260°C
Thermal Resistance ( $\theta_{JA}$ ) .....	160°C/W

## OPERATING CONDITIONS

Temperature Range	
ML4871CS-X .....	0°C to 70°C
ML4871ES-X .....	–20°C to 70°C
$V_{IN}$ Operating Range	
ML4871CS-X .....	1.8V to $V_{OUT} - 0.2V$
ML4871ES-X .....	2.0V to $V_{OUT} - 0.2V$

## ELECTRICAL CHARACTERISTICS

Unless otherwise specified,  $V_{IN}$  = Operating Voltage Range,  $T_A$  = Operating Temperature Range (Note 1).

SYMBOL	PARAMETER	CONDITIONS	MIN	TYP	MAX	UNITS	
<b>SUPPLY</b>							
$I_{IN}$	$V_{IN}$ Current	$V_{IN} = V_{OUT} - 0.2V$		2	5	$\mu A$	
$I_{OUT(Q)}$	$V_{OUT}$ Quiescent Current	DETECT = $V_{IN}$		30	40	$\mu A$	
		DETECT = 0V		25	35	$\mu A$	
$I_{L(Q)}$	$V_L$ Quiescent Current				1	$\mu A$	
<b>PFM REGULATOR</b>							
	$I_L$ Peak Current		1.2	1.4	1.7	A	
$V_{OUT}$	Output Voltage	$I_{L(PEAK)} = 0$	-3 Suffix	3.30	3.35	3.40	V
			-5 Suffix	4.95	5.05	5.15	V
	Load Regulation	See Figure 1, -3 Suffix $V_{IN} = 2.4V, I_{OUT} \leq 400mA$	3.20	3.25	3.40	V	
		See Figure 1, -5 Suffix $V_{IN} = 2.4V, I_{OUT} \leq 220mA$	4.85	4.95	5.15	V	
<b>RESET COMPARATOR</b>							
	DETECT Threshold		1.18	1.25	1.28	V	
	DETECT Hysteresis		25	35	45	mV	
	DETECT Bias Current		–100		100	nA	
	$\overline{RESET}$ Output High Voltage	$I_{RESET} = -200\mu A$	$V_{OUT} - 0.2$			V	
	$\overline{RESET}$ Output Low Voltage	$I_{RESET} = 500\mu A$			0.2	V	

**Note 1:** Limits are guaranteed by 100% testing, sampling, or correlation with worst case test conditions.

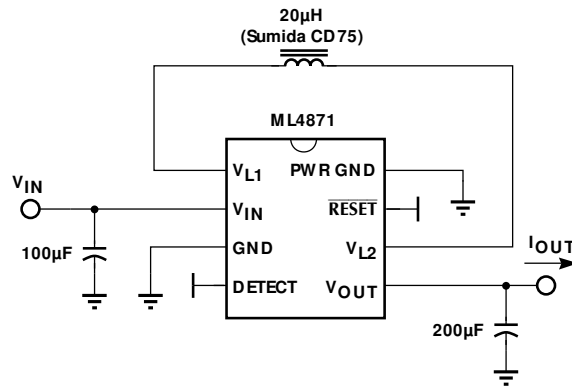

Figure 1. Application Test Circuit.

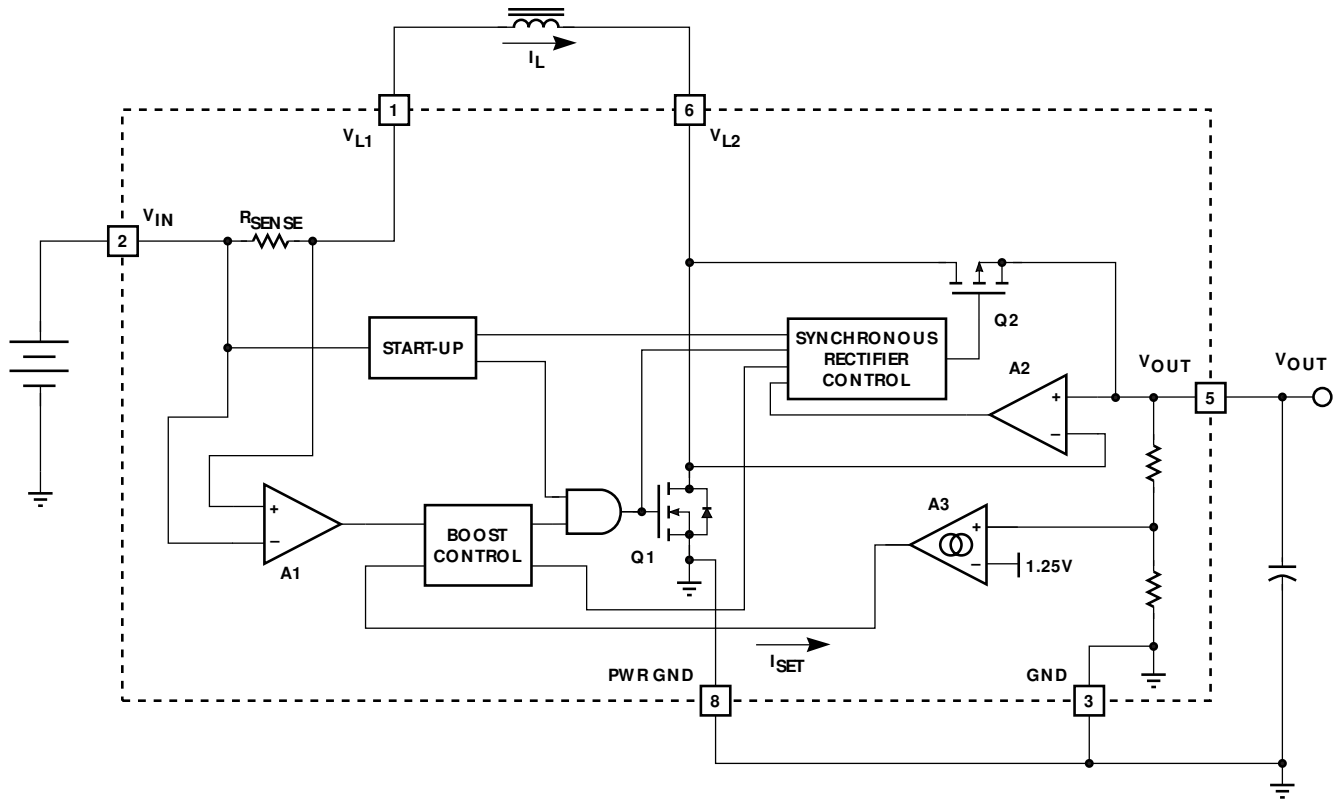

Figure 2. PFM Regulator Block Diagram.

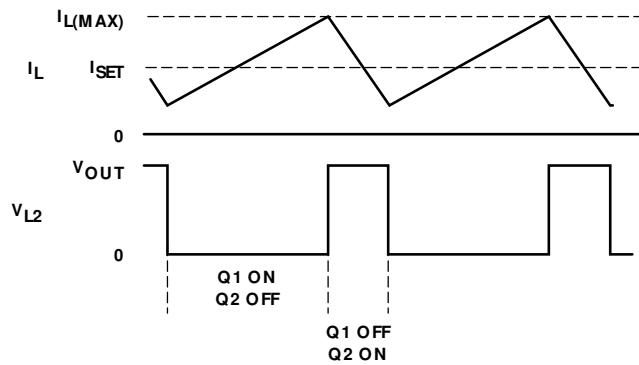

Figure 3. Inductor Current and Voltage Waveforms.

## FUNCTIONAL DESCRIPTION

The ML4871 combines a unique form of current mode control with a synchronous rectifier to create a boost converter that can deliver high currents while maintaining high efficiency. Current mode control allows the use of a very small, high frequency inductor and output capacitor. Synchronous rectification replaces the conventional external Schottky diode with an on-chip PMOS FET to reduce losses and eliminate an external component. Also included on-chip are an NMOS switch and current sense resistor, further reducing the number of external components, which makes the ML4871 very easy to use.

### REGULATOR OPERATION

The ML4871 is a variable frequency, current mode switching regulator. Its unique control scheme converts efficiently over more than three decades of load current. A block diagram of the boost converter is shown in Figure 2.

Error amp A3 converts deviations in the desired output voltage to a small current,  $I_{SET}$ . The inductor current is measured through a  $50m\Omega$  resistor which is amplified by A1. The boost control block matches the average inductor current to a multiple of the  $I_{SET}$  current by switching Q1 on and off. The peak inductor current is limited by the controller to about 1.5A.

At light loads,  $I_{SET}$  will momentarily reach zero after an inductor discharge cycle, causing Q1 to stop switching. Depending on the load, this idle time can extend to tenths of seconds. While the circuit is not switching, only  $20\mu A$  of supply current is drawn from the output. This allows the part to remain efficient even when the load current drops below  $200\mu A$ .

Amplifier A2 and the PMOS transistor Q2 work together to form a low drop diode. When transistor Q1 turns off, the current flowing in the inductor causes pin 6 to go high. As the voltage on  $V_{L2}$  rises above  $V_{OUT}$ , amplifier A2 allows the PMOS transistor Q2 to turn on. In discontinuous operation, (where  $I_L$  always returns to zero), A2 uses the resistive drop across the PMOS switch Q2 to sense zero inductor current and turns the PMOS switch off. In continuous operation, the PMOS turn off is independent of A2, and is determined by the boost control circuitry.

Typical inductor current and voltage waveforms are shown in Figure 3.

### RESET COMPARATOR

An additional comparator is provided to detect low  $V_{IN}$ , low  $V_{OUT}$ , or any other error condition that the user may want to sense. The inverting input of the comparator is connected to the 1.25V reference, and the non-inverting input is connected to the **DETECT** pin. The output of this comparator is connected to the **RESET** pin of the device and can swing from  $V_{OUT}$  to ground.

## DESIGN CONSIDERATIONS

### OUTPUT CURRENT CAPABILITY

The maximum current available at the output of the regulator is related to the maximum inductor current by the ratio of the input to output voltage and the full load efficiency. The maximum inductor current is approximately 1.25A and the full load efficiency may be as low as 70%. The maximum output current can be determined by using the typical performance curves shown in Figures 4 and 5, or by calculation using the following equation:

$$I_{OUT(MAX)} = 1.25 \times \left( \frac{V_{IN(MIN)}}{V_{OUT}} \right) \times 0.7A \quad (1)$$

### INDUCTOR SELECTION

The ML4871 is able to operate over a wide range of inductor values. A value of  $10\mu H$  is a good choice, but any value between  $5\mu H$  and  $33\mu H$  is acceptable. As the inductor value is changed the control circuitry will automatically adjust to keep the inductor current under control. Choosing an inductance value of less than  $10\mu H$  will reduce the component's footprint, but the efficiency and maximum output current may drop.

It is important to use an inductor that is rated to handle 1.5A peak currents without saturating. Also look for an inductor with low winding resistance. A good rule of thumb is to allow 5 to  $10m\Omega$  of resistance for each  $\mu H$  of inductance.

The final selection of the inductor will be based on trade-offs between size, cost and efficiency. Inductor tolerance, core and copper loss will vary with the type of inductor selected and should be evaluated with a ML4871 under worst case conditions to determine its suitability.

Several manufacturers supply standard inductance values in surface mount packages:

Coilcraft	(847) 639-6400
Coiltronics	(561) 241-7876
Dale	(605) 665-9301
Sumida	(847) 956-0666

## DESIGN CONSIDERATIONS (Continued)

### OUTPUT CAPACITOR

The output capacitor filters the pulses of current from the switching regulator. Since the switching frequency will vary with inductance, the minimum output capacitance required to reduce the output ripple to an acceptable level will be a function of the inductor used. Therefore, to maintain an output voltage with less than 100mV of ripple at full load current, use the following equation:

$$C_{OUT} = \frac{44 \times L}{V_{OUT}} \quad (2)$$

The output capacitor's Equivalent Series Resistance (ESR) and Equivalent Series Inductance (ESL), also contribute to the ripple. Just after the NMOS transistor, Q1, turns off, the

current in the output capacitor ramps quickly to between 0.5A and 1.5A. This fast change in current through the capacitor's ESL causes a high frequency (5ns) spike to appear on the output. After the ESL spike settles, the output still has a ripple component equal to the inductor discharge current times the ESR. To minimize these effects, choose an output capacitor with less than 10nH of ESL and 100mΩ of ESR.

Suitable tantalum capacitors can be obtained from the following vendors:

AVX	(207) 282-5111
Kemet	(846) 963-6300
Sprague	(207) 324-4140

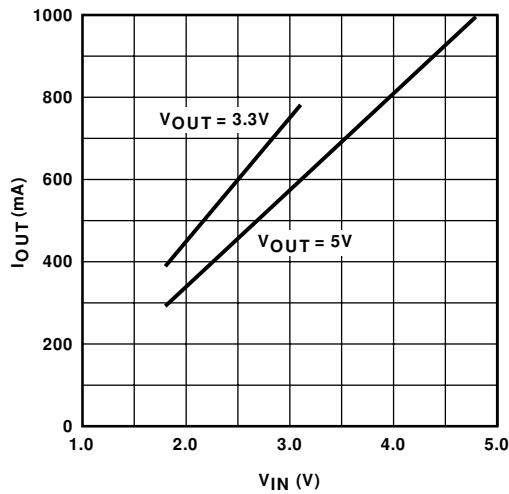

Figure 4.  $I_{OUT}$  vs.  $V_{IN}$  Using the Circuit of Figure 8

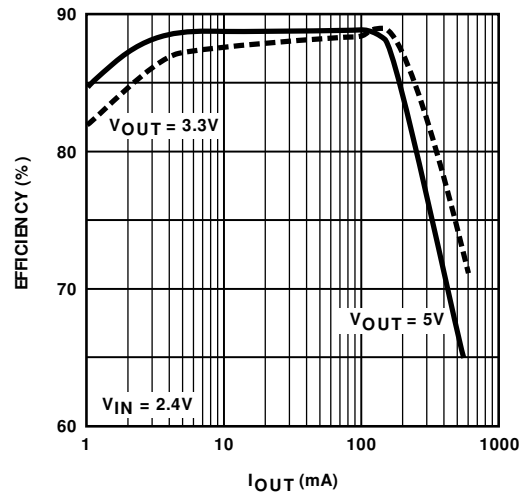

Figure 5. Efficiency vs.  $I_{OUT}$  Using the Circuit of Figure 8

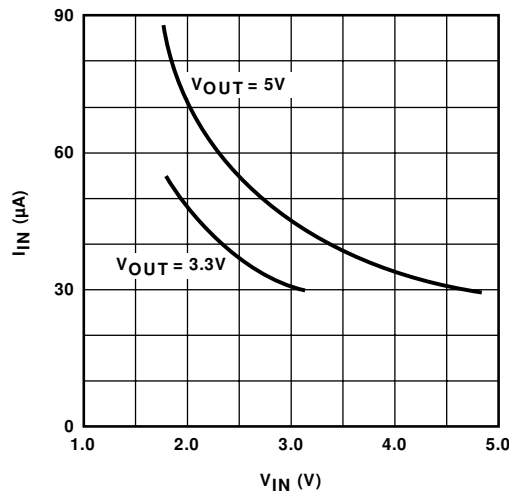

Figure 6. No Load Input Current vs.  $V_{IN}$

## DESIGN CONSIDERATIONS (Continued)

### INPUT CAPACITOR

Due to the high input current drawn at startup and possibly during operation, it is recommended to decouple the input with a capacitor with a value of 47 $\mu$ F to 100 $\mu$ F. This filtering prevents the input ripple from affecting the ML4871 control circuitry, and also improves the efficiency by reducing the I squared R losses during the charge cycle of the inductor. Again, a low ESR capacitor (such as tantalum) is recommended.

It is also recommended that low source impedance batteries be used. Otherwise, the voltage drop across the source impedance during high input current situations will cause the ML4871 to fail to start-up or to operate unreliably. In general, for two cell applications the source impedance should be less than 200m $\Omega$ , which means that small alkaline cells should be avoided.

### BATTERY MONITORING

The condition of the batteries can be monitored using the DETECT pin. For primary batteries, the comparator can be used to signal that the batteries will soon need to be replaced. For rechargeable batteries, the comparator can be used to signal the start of a charging cycle.

For input voltages greater than the minimum operating voltage, the RESET pin can be set to go low at a specified battery voltage by connecting a resistor divider across the battery stack and to the DETECT pin of the ML4871 as shown in Figure 7. The low battery trip voltage is determined by first choosing a minimum battery voltage,  $V_{IN(MIN)}$ , and then calculating the values of  $R_A$  and  $R_B$ :

$$V_{IN(MIN)} = 1.25 \times \frac{(R_A + R_B)}{R_B} \quad (3)$$

The values of  $R_A$  and  $R_B$  should be sufficiently large to minimize the power dissipation in the divider. Also, use care when selecting the low battery trip point. Too high a trip voltage can lead to memory effects in the battery, while too low a trip point can lead to reduced service life or polarity reversal. Refer to the manufacturer's data sheets for more information on selecting and designing battery systems.

## LAYOUT

Good layout practices will ensure the proper operation of the ML4871. Some layout guidelines follow:

- Use adequate ground and power traces or planes
- Keep components as close as possible to the ML4871
- Use short trace lengths from the inductor to the  $V_{L1}$  and  $V_{L2}$  pins and from the output capacitor to the  $V_{OUT}$  pin
- Use a single point ground for the ML4871 ground pin, and the input and output capacitors
- Separate the ground for the converter circuitry from the ground of the load circuitry and connect at a single point

A sample layout is shown in Figure 8.

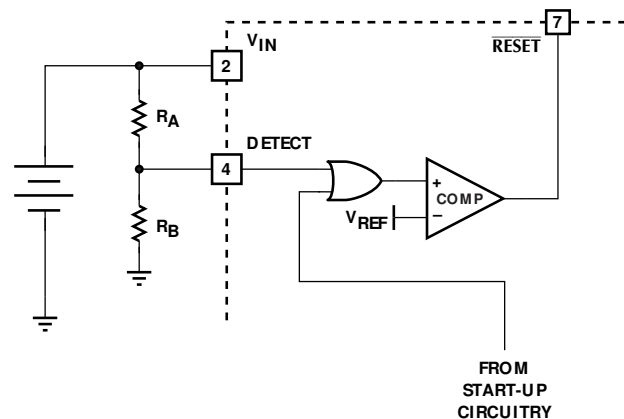

Figure 7. Battery Monitoring Circuit

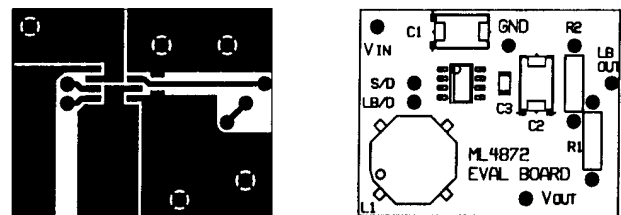

Figure 8. Sample PC Board Layout

# ML4871

## DESIGN EXAMPLE

In order to design a boost converter using the ML4871, it is necessary to define a few parameters. For this example, assume that  $V_{IN} = 3.0V$  to  $3.6V$ ,  $V_{OUT} = 5.0V$ , and  $I_{OUT(MAX)} = 500mA$ .

First, it must be determined whether the ML4871 is capable of delivering the output current. This is done using Equation 1:

$$I_{OUT(MAX)} = 1.25 \times \left( \frac{3.0V}{5.0V} \right) \times 0.7A = 0.53A$$

Next, select an inductor. As previously mentioned, the recommended inductance is  $10\mu H$ . Make sure that the peak current rating of the inductor is at least  $1.5A$ , and that the DC resistance of the inductor is in the range of  $50$  to  $100m\Omega$ .

Finally, the value of the output capacitor is determined using Equation 2:

$$C_{OUT} = \frac{44 \times 10\mu H}{5.0V} = 88\mu F$$

The closest standard value would be a  $100\mu F$  capacitor with an ESR rating of  $100m\Omega$ . If such a low ESR value cannot be found, two  $47\mu F$  capacitors in parallel could also be used.

The complete circuit is shown in Figure 9. As mentioned previously, the use of an input supply bypass capacitor is highly recommended.

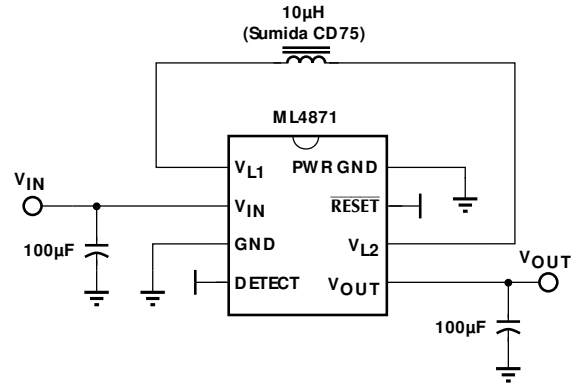

Figure 9. Typical Application Circuit

$V_{IN}$ (V)	$I_{OUT(MAX)}$ (mA)	
	$V_{OUT} = 3.3V$	$V_{OUT} = 5.0V$
1.8	386.2	286.2
2.0	451.9	332.1
2.2	521.5	379.1
2.4	585.9	430.0
2.6	651.0	479.0
2.8	716.5	525.4
3.0	782.0	571.8
3.2		618.5
3.4		665.0
3.6		711.7
3.8		758.7
4.0		805.3
4.2		851.9
4.4		899.0
4.6		946.1
4.8		992.7

$I_{OUT}$ (mA)	EFFICIENCY PERCENTAGE
$V_{IN} = 2.4V, V_{OUT} = 3.3V$	
1.0	82.0
2.0	84.4
5.0	87.0
10.0	87.6
20.0	87.9
50.0	88.3
100.0	88.6
200.0	88.2
586.0	65.1
$V_{IN} = 2.4V, V_{OUT} = 5.0V$	
1.0	84.4
2.0	87.0
5.0	87.7
10.0	88.4
20.0	88.9
50.0	89.1
100.0	88.9
200.0	87.5
485.0	71.6

Table 1. Typical  $I_{OUT}$  and Efficiency vs.  $V_{IN}$

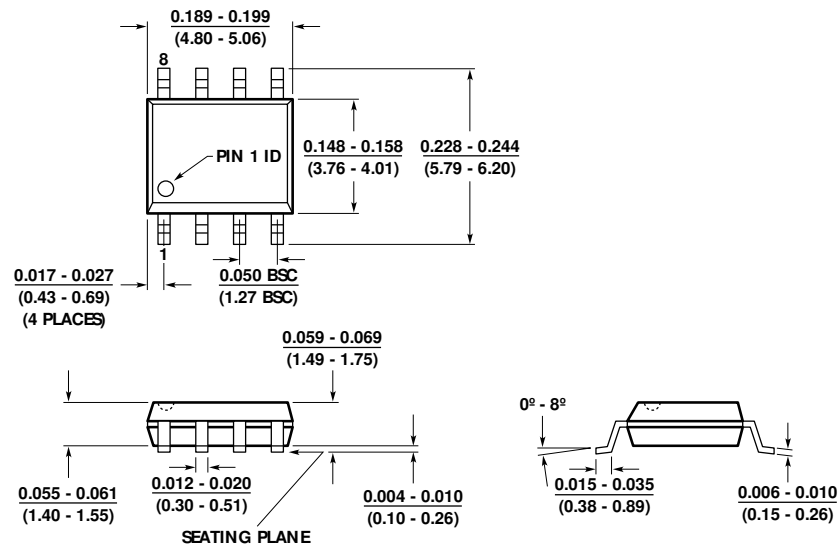

**PHYSICAL DIMENSIONS** inches (millimeters)

**Package: S08**  
**8-Pin SOIC**

**ORDERING INFORMATION**

PART NUMBER	OUTPUT VOLTAGE	TEMPERATURE RANGE	PACKAGE
ML4871CS-3	3.3V	0°C to 70°C	8-Pin SOIC (S08)
ML4871CS-5	5.0V	0°C to 70°C	8-Pin SOIC (S08)
ML4871ES-3	3.3V	-20°C to 70°C	8-Pin SOIC (S08)
ML4871ES-5	5.0V	-20°C to 70°C	8-Pin SOIC (S08)

**DISCLAIMER**

FAIRCHILD SEMICONDUCTOR RESERVES THE RIGHT TO MAKE CHANGES WITHOUT FURTHER NOTICE TO ANY PRODUCTS HEREIN TO IMPROVE RELIABILITY, FUNCTION OR DESIGN. FAIRCHILD DOES NOT ASSUME ANY LIABILITY ARISING OUT OF THE APPLICATION OR USE OF ANY PRODUCT OR CIRCUIT DESCRIBED HEREIN; NEITHER DOES IT CONVEY ANY LICENSE UNDER ITS PATENT RIGHTS, NOR THE RIGHTS OF OTHERS.

**LIFE SUPPORT POLICY**

FAIRCHILD'S PRODUCTS ARE NOT AUTHORIZED FOR USE AS CRITICAL COMPONENTS IN LIFE SUPPORT DEVICES OR SYSTEMS WITHOUT THE EXPRESS WRITTEN APPROVAL OF THE PRESIDENT OF FAIRCHILD SEMICONDUCTOR CORPORATION. As used herein:

- Life support devices or systems are devices or systems which, (a) are intended for surgical implant into the body, or (b) support or sustain life, and (c) whose failure to perform when properly used in accordance with instructions for use provided in the labeling, can be reasonably expected to result in a significant injury of the user.
- A critical component in any component of a life support device or system whose failure to perform can be reasonably expected to cause the failure of the life support device or system, or to affect its safety or effectiveness.