

THIS IS A CAD GENERATED DRAWING  
DO NOT MAKE MANUAL REVISIONS TO MASTER.

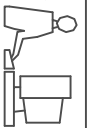

ISSUE NUMBER  
ORIGINAL ①

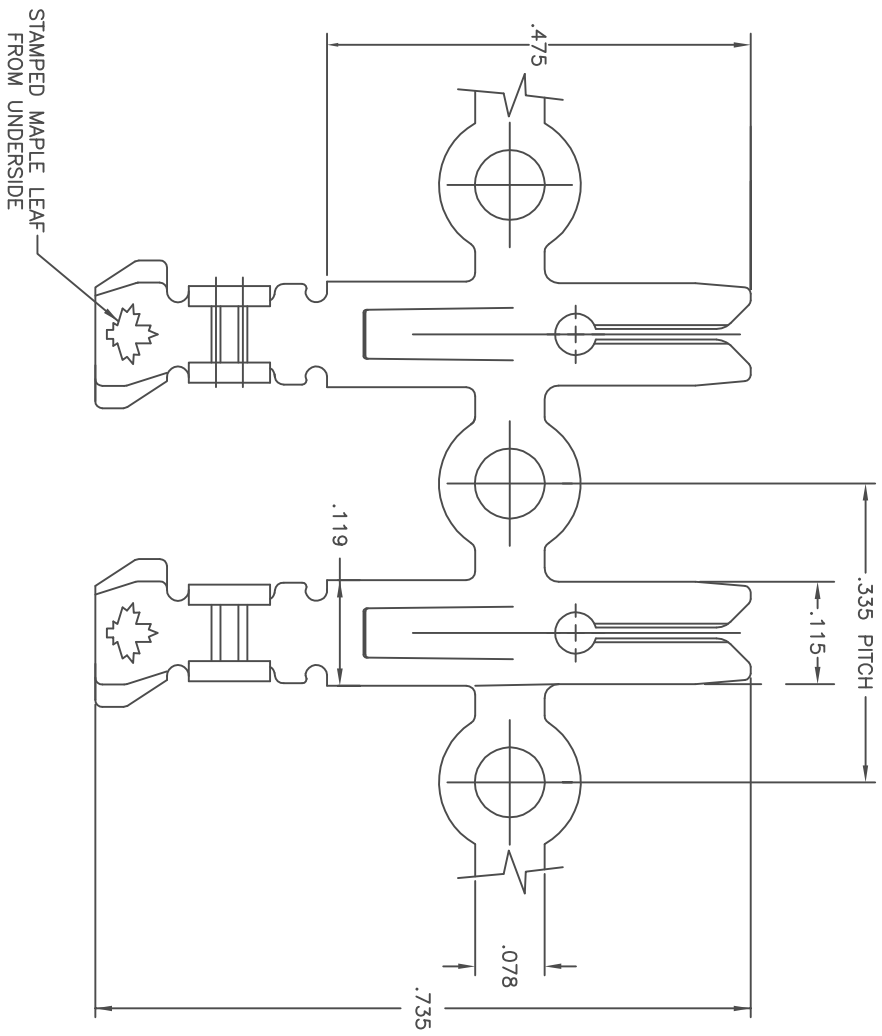

NOTES:

- 1) MATERIAL:  $\pm .0005$  .0225 THICK PHOSPHOR BRONZE, GRADE A, 95000-105000 PSI TENSILE.

516 CRIMP CONTACT DETAIL FOR  
516-290-571 AND 516-294-571 REELS

**EDAC INC** EDAC INC  
TORONTO, ONTARIO  
CANADA  
YOUR CONNECTION TO QUALITY & SERVICE

ACAD REFERENCE NO.	51629001
DRAWN: F.BRIONES	DATE: OCT.24/07
PART NUMBER	516-290-571, 516-294-571
DRAWING NUMBER	516-290-571, 516-294-571
ISSUE	1

THESE DRAWINGS AND SPECIFICATIONS  
ARE THE PROPERTY OF EDAC INC. AND  
SHALL NOT BE REPRODUCED OR COPIED  
OR USED AS THE BASIS FOR THE  
MANUFACTURE OR SALE OF APPARATUS  
WITHOUT WRITTEN PERMISSION.

THIS IS A C.A.D. GENERATED DRAWING  
DO NOT MAKE MANUAL REVISIONS TO MASTER.



ISSUE NUMBER

ORIGINAL

①

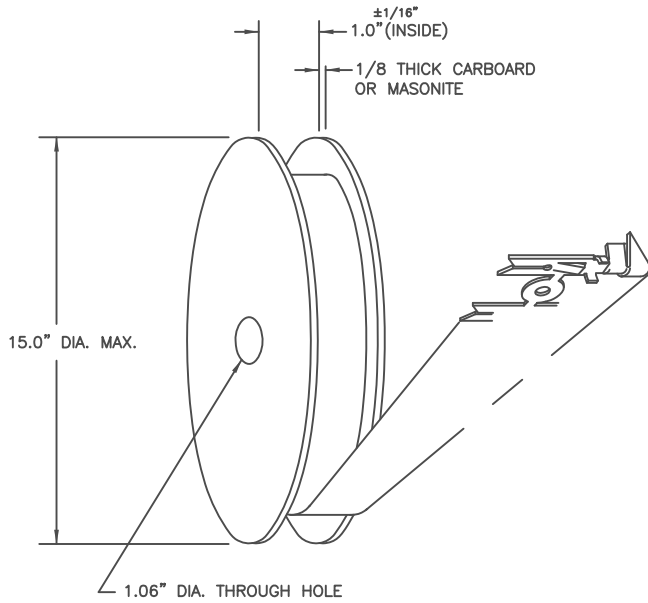

PART NUMBER 516-290-571

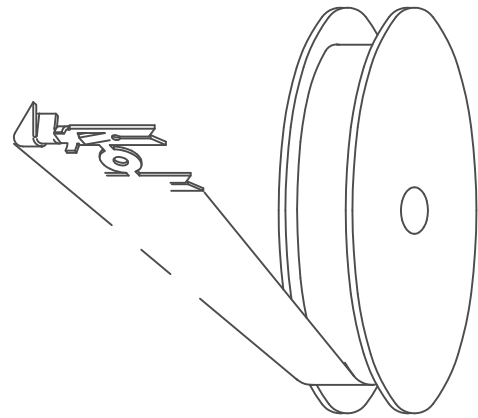

PART NUMBER 516-294-571

NOTES:

- 1) EACH REEL SHALL CONTAIN A CONTINUOUS STRIP OF 1800 +/-20 CONTACTS. NO BREAKS OR JOININGS PERMITTED IN CONTACT CARRIER. MAXIMUM 2 CONTACTS PER REEL MAY BE OMITTED (CUT AWAY FOR TESTING PURPOSES).
- 2) CONTACTS TO BE WOUND ONTO REEL IN ACCORDANCE WITH ALL VIEWS.
- 3) DO NOT INTERLEAVE PAPER BETWEEN CONTACTS.

516 SERIES CRIMP CONTACTS ON REEL  
ORIENTATION-READY FOR CUSTOMER USE

ACAD REFERENCE NO. 51629001

DRAWN: F.BRIONES

DATE: JULY 4/97

CHECKED:

DATE:

SCALE:

SHEET 1 OF 1

DRAWING NUMBER

516-290-013

ISSUE

1



EDAC INC  
TORONTO, ONTARIO  
CANADA

YOUR CONNECTION TO QUALITY & SERVICE

THESE DRAWINGS AND SPECIFICATIONS ARE THE PROPERTY OF EDAC INC., AND SHALL NOT BE REPRODUCED, OR COPIED OR USED AS THE BASIS FOR THE MANUFACTURE OR SALE OF APPARATUS WITHOUT WRITTEN PERMISSION.