

REVISIONS				
ZONE	LTR	DESCRIPTION	DATE	APPROVED
A		NEW RELEASE PER E.O. #23612	09/06	DEC
B		REVISED PER ECN #23783	11/06	DEC
C		REVISED PER ECN #301254	05/10	LLF
D		REVISED PER ECN #302213	08/11	LLF

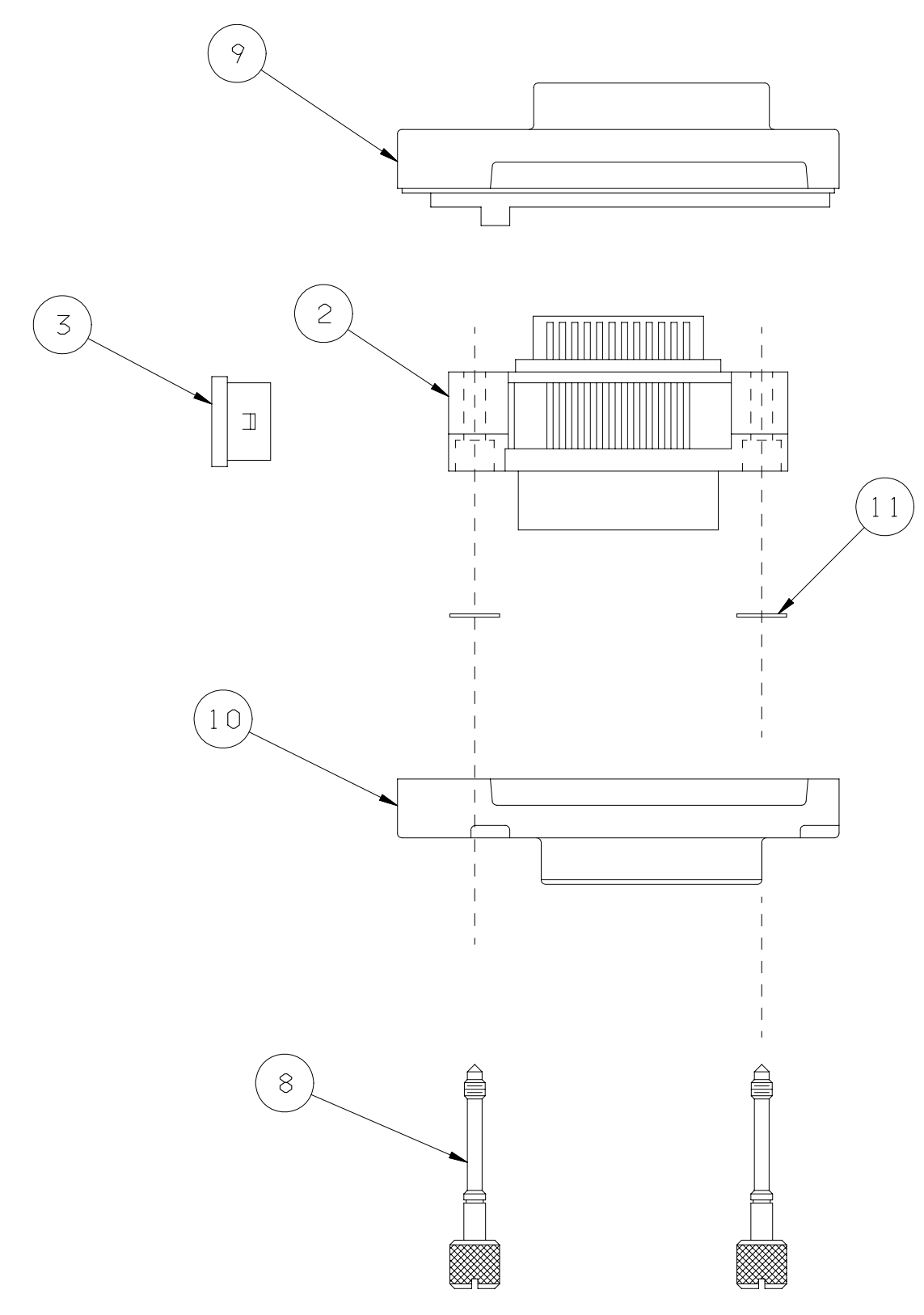
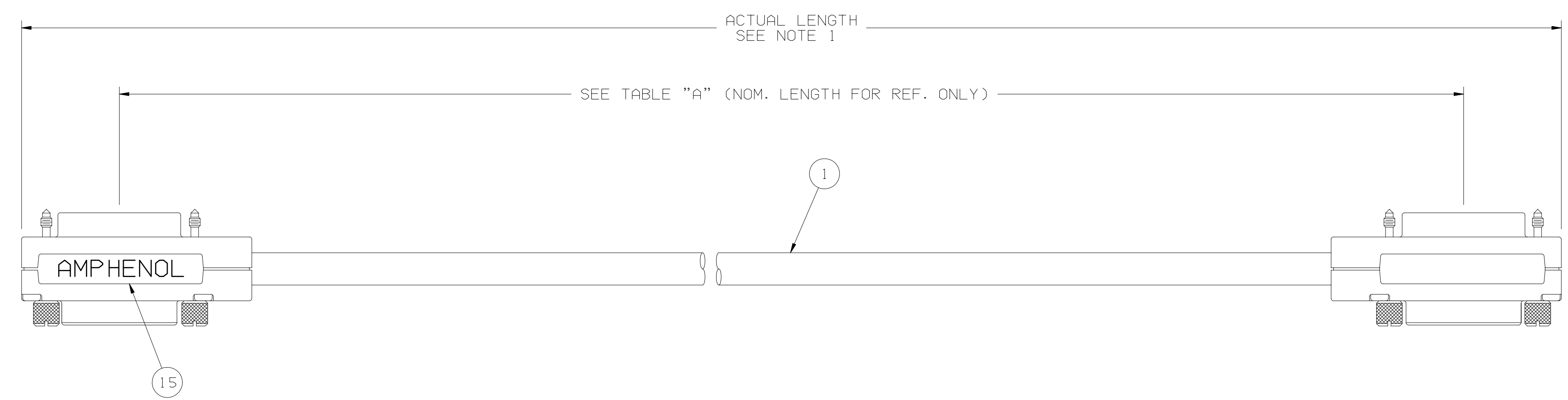

TABLE A

AMPHENOL P/N	AMPH.ACD P/N	NOM. LENGTH	ACTUAL LENGTH
56020XX01	GP-IE515546DS-000.3	.3 METER	.4 METER +.10/-.05
56020XX02	GP-IE515546DS-000.5	.5 METER	.6 METER +.10/-.05
56020XX03	GP-IE515546DS-001	1 METER	1.1 METER +.15/-.05
56020XX04	GP-IE515546DS-002	2 METER	2.1 METER +.15/-.05
56020XX05	GP-IE515546DS-002.5	2.5 METER	2.6 METER +.15/-.05
56020XX06	GP-IE515546DS-003	3 METER	3.1 METER +.15/-.05
56020XX07	GP-IE515546DS-004	4 METER	4.1 METER +.15/-.05
56020XX08	GP-IE515546DS-005	5 METER	5.1 METER +.15/-.05
56020XX09	GP-IE515546DS-006	6 METER	6.1 METER +.15/-.05
56020XX10	GP-IE515546DS-008	8 METER	8.1 METER +.15/-.05
56020XX11	GP-IE515546DS-010	10 METER	10.1 METER +.20/-.05
56020XX12	GP-IE515546DS-012	12 METER	12.1 METER +.20/-.05
56020XX13	GP-IE515546DS-015	15 METER	15.1 METER +.20/-.05
56020XX14	GP-IE515546DS-018	18 METER	18.1 METER +.20/-.05

WIRE RUN LIST

PIN ASSIGNMENTS (TYP. ALL CONNECTORS)			
PIN NUMBER	WIRE COLOR	PIN NUMBER	WIRE COLOR
1	WHT/BRN *	13	WHT/GRN *
2	WHT/RED *	14	WHT/BLU *
3	WHT/ORN *	15	WHT/GRAY *
4	WHT/YEL *	16	WHITE *
5	BLACK	17	VIOLET
6	BROWN	18	WHT/BRN
7	RED	19	WHT/RED
8	ORANGE	20	WHT/ORN
9	YELLOW	21	WHT/YEL
10	GREEN	22	WHT/GRN
11	BLUE	23	WHT/BLU
12	OUTER DRAIN	24	WHT/BLK
		24	WHT/VIO
		24	INNER DRAIN

* = INNER CORE COLORS

9. SIMILAR TO AMPHENOL DRAWING 51554XXXX.
8. APPLY ANTI-STATIC BUBBLE WRAP OVER EACH END ON EACH ASSEMBLY.
7. ALL MATERIALS USED IN THE MANUFACTURE OF THIS ASSEMBLY SHALL COMPLY WITH AMPHENOL REGULATED MATERIALS SPECIFICATION CS-1152.
6. EACH ASSEMBLY IS TO BE PACKAGED IN PINK ANTI-STATIC PLASTIC BAG MATERIAL.
5. DELETED.
4. MAXIMUM ALLOWABLE ROTATION OF STRAIN RELIEF IN ASSEMBLY SHALL BE 15 DEGREES.
3. CRIMP IN CRIMP RING IS TO MATE WITH ANTI-ROTATION PROTRUSION OF HOUSING HALVES.
2. ASSEMBLY TESTING:
 - A) EACH CABLE SHALL BE TESTED TO ENSURE THAT THERE ARE NO DISCONTINUITIES AND NO SHORTS EXIST.
 - B) NO SHORT SHALL EXIST BETWEEN ADJACENT PINS. (I.E. 1 & 2, 2 & 3 ...)
 - C) A "SHORT IS DEFINED AS A RESISTANCE OF LESS THAN 20 MEGAOHMS.
 - D) A DISCONTINUITY IS DEFINED AS A RESISTANCE OF 2 OHMS OR GREATER.
1. THIS DIMENSION TABULATED UNDER 'ACTUAL LENGTH' IN TABLE A.

NOTES: UNLESS OTHERWISE SPECIFIED

The Information Contained In This Drawing Is the Sole Property Of Amphenol Interconnect Products Corporation. Any Reproduction or Disclosure, To Third Parties, In Part, Or In Whole, Without the Express Written Permission of Amphenol Interconnect Products Corporation Is Prohibited

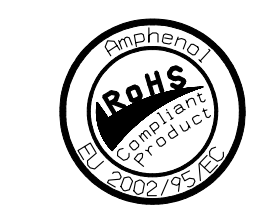

SPECIFICATION CONTROL DRAWING

UNLESS OTHERWISE SPECIFIED DIMENSIONS ARE IN INCHES TOLERANCE ON		EAR NO.		Amphenol Interconnect Products <small>20 VALLEY ST. ENDCOTT, N.Y. 13760</small>	
FRAC-TION	DECIMAL	ANGLE	SIGNATURES	DATE	CABLE ASSEMBLY, ROUND-24 POSITION IEEE PLUG/RCPT, DIECAST ENCLOSURE, PREMIUM
±	± .X ± .XX ± .XXX	±	DRAWN D. CASHIMERE	09/06	
			CHECKED		
			APPROVED		
			APPROVED		SIZE D 56020XXXX
				SCALE: NONE	REV D SHEET 1 OF 1