

WF52 Datasheet

Amp'ed RF Technology, Inc.

WF52 Product Specification



14.6mm x 13.5mm x 2.6 mm

Description

Amp'ed RF Tech presents the WF52 Wi-Fi Stand-alone module: 802.11abgn + Host MCU with Wi-Fi protocol stack. The WF52 is a small footprint low cost RF module with external antenna, 6 general purpose and ADC IO lines, several serial interface options, and up to 10M bps data throughput using the SPI interface.

The complete stack, TCP/IP with WLAN, is hosted on the integrated MCU. A simple AT command interface, artSerial, allows users to easily configure and operate the WF52.

WLAN features

- 802.11a/b/g/n, dual band
- Output Power, +23dBm
- Power savings mode
- Transmit power back-off
- Wi-Fi Direct (concurrent)
- Wi-Fi Protected Setup
- Soft Access Point
- Hotspot 2.0
- Security: WPA2, AES

Hardware configuration

- Cortex-M4 100MHz MCU
- 512K bytes Flash memory
- 128K bytes RAM memory
- UART, up to 2.25M baud
- SPI and I2C interfaces
- 6 general purpose I/O
- 2 x12-bit A/D inputs
- 1 LPO input
- Standby current, 60 μ A
- RoHS conformance

Embedded software

- Amp'edUP WiFi stack
- artSerial, AT command set, Software Development Kit
- Mobile application software

Table of Contents

1. Software Architecture	4
1.1. Protocol stack diagram	4
1.2. Wi-Fi features	4
2. Hardware Specifications	5
2.1. Recommended Operating Conditions	5
2.2. Absolute Maximum Ratings	5
2.3. I/O Operating Conditions	5
2.4. Current Consumption	6
2.5. Selected RF Characteristics	6
2.6. Transmit Power Back-off	7
2.7. Pin Assignment	9
2.8. Pin Placement Diagram	10
2.9. Layout Drawing	11
3. Hardware Design	12
3.1. Block Diagram	12
3.2. Layout	12
3.3. Module Reflow	12
3.4. GPIO Interface	12
3.5. UART Interface	12
3.6. Reset Circuit	13
3.7. Reference design	14
3.8. External LPO Input Circuit	15
4. Regulatory Compliance	15
4.1. Modular Approval, FCC and IC	17
4.2. FCC Label Instructions	17
4.3. CE Label Instructions	17
5. Ordering Information	17
6. Revision History	18

1. Software Architecture

1.1. Protocol stack diagram

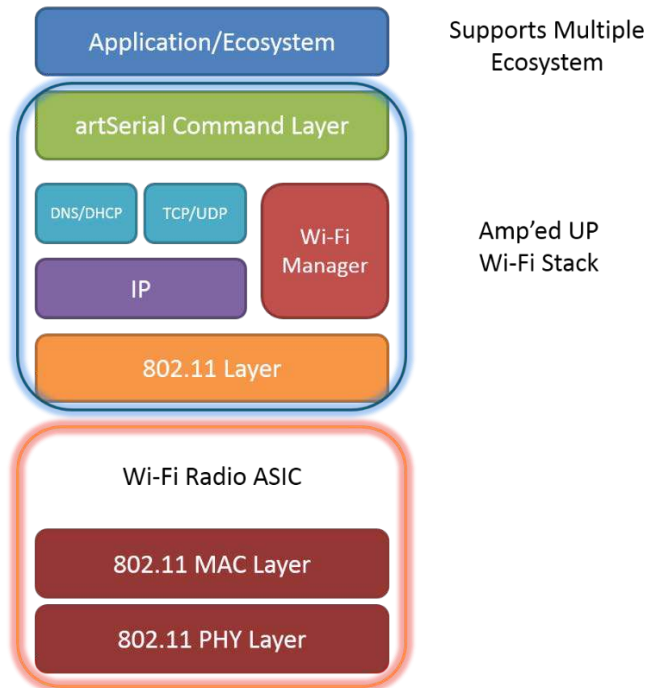

1.2. Wi-Fi features

- 802.11a/b/g/n, dual band
- 802.11d Regulatory Domain, 802.11r
- Output Power, +23dBm
- Interface, SDIO 2.0, SPI
- Wi-Fi Direct (concurrent)
- Wi-Fi Display
- Wi-Fi Protected Setup
- Soft Access Point
- Hotspot 2.0
- Security: WPA2, AES
- CCX v4 Client Security

2. Hardware Specifications

General Conditions ($V_{IN} = 3.6V$ and $25^{\circ}C$)

2.1. Recommended Operating Conditions

Rating	Min	Typical	Max	Unit
Operating Temperature Range	-40	-	85	$^{\circ}C$
Supply Voltage V_{IN}	2.3	3.6	4.8	Volts
Signal Pin Voltage	-	2.0	-	Volts
RF Frequency	2400	-	2495	MHz

2.2. Absolute Maximum Ratings

Rating	Min	Typical	Max	Unit
Storage temperature range	-55	-	+150	$^{\circ}C$
Supply voltage V_{IN}	-0.3	-	+5.0	Volts
I/O pin voltage V_{IO}	-0.3	-	+2.5	Volts
RF input power	-	-	-5	dBm

2.3. I/O Operating Conditions

Symbol	Parameter	Min	Max	Unit
V_{IL}	Low-Level Input Voltage	-	0.6	Volts
V_{IH}	High-Level Input Voltage	1.3	-	Volts
V_{OL}	Low-Level Output Voltage	-	0.4	Volts
V_{OH}	High-Level Output Voltage	2.0	-	Volts
I_{OL}	Low –Level Output Current	-	4.0	mA
I_{OH}	High-Level Output Current	-	4.0	mA
R_{PU}	Pull-up Resistor	80	120	K Ω
R_{PD}	Pull-down Resistor	80	120	K Ω

2.4. Current Consumption

Modes (WLAN Max Power Level) V _{BAT} =3.6V, CPU 42Mhz	Avg	Unit
Complete Power Down	17	μA
Sleep	101	μA
Power save (beacon period (including DTIM) 100ms, beacon length 1ms) -proprietary power saving features enabled	0.77	mA
RX (idle, 2.4GHz)	62.07	mA
RX (active, 2.4GHz, OFDM)	65.87	mA
TX (active, 2.4GHz, OFDM), 15.5dBm @RF port	257.67	mA
TX (active, 2.4GHz, OFDM), 20.5dBm @RF port	279.67	mA
Video streaming; the device is receiving 2.0 Mbps of data using legacy PSM mode (for example, MPEG-4@2Mbps)	13.31	mA
I _{peak} : system maximum peak current draw	378	mA

2.5. Selected RF Characteristics

Parameters	Conditions	Typical	Unit
Antenna load		50	ohm
Wi-Fi Receiver			
Sensitivity	DSSS 1Mbps@FER<8%	-98.0	dBm
Sensitivity	DSSS 2Mbps@FER<8%	-95.0	dBm
Sensitivity	CCK 5.5Mbps@FER<8%	-93.0	dBm
Sensitivity	CCK 11Mbps@FER<8%	-91.5	dBm
Sensitivity	BPSK 6Mbps@PER<10%	-93.5	dBm
Sensitivity	BPSK 9Mbps@PER<10%	-91.5	dBm
Sensitivity	QPSK 12Mbps@PER<10%	-90.5	dBm
Sensitivity	QPSK 18Mbps@PER<10%	-88.0	dBm
Sensitivity	16QAM 24Mbps@PER<10%	-85.5	dBm
Sensitivity	16QAM 36Mbps@PER<10%	-82.0	dBm
Sensitivity	64QAM 48Mbps@PER<10%	-78.0	dBm
Sensitivity	64QAM 54Mbps@PER<10%	-76.5	dBm
Sensitivity	BPSK 6.5Mbps@PER<10%	-92.0	dBm
Sensitivity	QPSK 13Mbps@PER<10%	-89.0	dBm

Sensitivity	QPSK 19.5Mbps@PER<10%	-86.5	dBm
Sensitivity	16QAM 26Mbps@PER<10%	-84.0	dBm
Sensitivity	16 QAM 39Mbps@PER<10%	-80.5	dBm
Sensitivity	64QAM 52Mbps@PER<10%	-76.5	dBm
Sensitivity	64QAM 58.5Mbps@PER<10%	-74.5	dBm
Sensitivity	64QAM 65Mbps@PER<10%	-73.0	dBm
Wi-Fi Transmitter			
Output Power	802.11b/g BPSK 1/2	21.25	dBm
Output Power	802.11b/g BPSK 3/4	21.25	dBm
Output Power	802.11b/g QPSK 1/2	21.25	dBm
Output Power	802.11b/g QPSK 3/4	21.25	dBm
Output Power	802.11b/g 16QAM 1/2	21.25	dBm
Output Power	802.11b/g 16QAM 3/4	20.25	dBm
Output Power	802.11b/g 64QAM 2/3	19.25	dBm
Output Power	802.11b/g 64QAM 3/4	18.25	dBm
Output Power	802.11n MCS-0	21.25	dBm
Output Power	802.11n MCS-1	21.25	dBm
Output Power	802.11n MCS-2	21.25	dBm
Output Power	802.11n MCS-3	21.25	dBm
Output Power	802.11n MCS-4	20.25	dBm
Output Power	802.11n MCS-5	19.25	dBm
Output Power	802.11n MCS-6	18.25	dBm
Output Power	802.11n MCS-7	17.0	dBm

2.6. Transmit Power Back-off

When $2.7\text{ V} < V_{\text{BAT}} < 3.6\text{ V}$, the output power shall be backed off by 0.8 dB per 300 mV drop of V_{bat} below 3.6 V to guarantee meeting spectral mask, EVM, harmonic levels, spurious emissions and regulatory requirements in general.

When $2.3\text{ V} < V_{\text{BAT}} < 2.7\text{ V}$, an additional back-off of the output power is needed to guarantee meeting spectral mask, EVM, harmonic levels, spurious emissions and regulatory requirements in general.

When the load is not 50Ω, the output power is backed off to guarantee meeting spectral mask, EVM, harmonic levels, spurious emissions and regulatory requirements in general. The device is able to withstand a VSWR of up to 12:1 without any damage.

When the temperature increases from +25°C to +85°C, the output power shall be backed off

by 0.25 dB per 10°C increase to guarantee meeting spectral mask, EVM, harmonic levels, spurious emissions and regulatory requirements in general.

Tx Power vs Vin

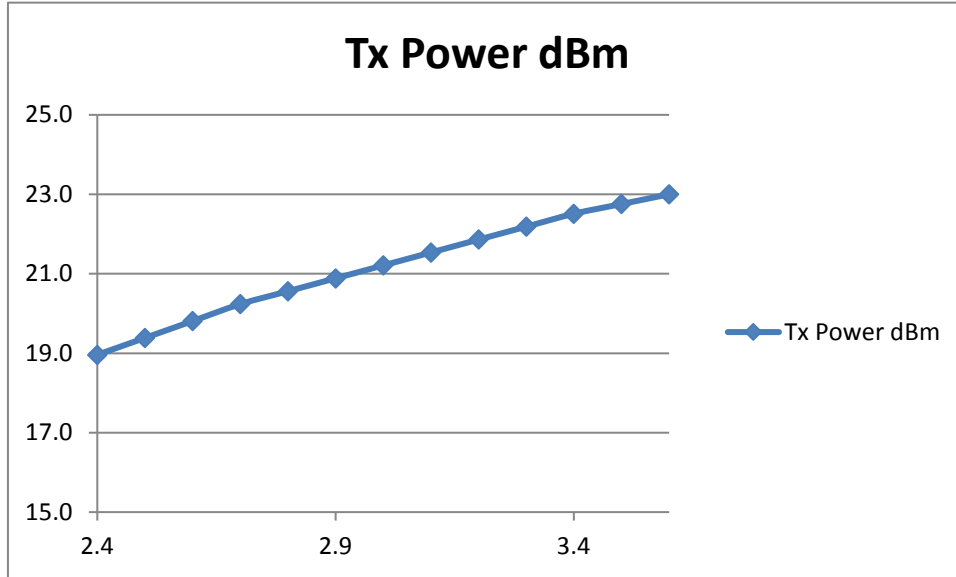

2.7. Pin Assignment

Name	Type	Pin #	Description	ALT Function	5V Tolerant	Initial State
UART Interface						
RXD	I	13	Receive data		Y	
TXD	O	14	Transmit data		Y	
RTS	O	12	Request to send (active low)	I2C Data/Aux Uart Rx	Y	
CTS	I	11	Clear to send (active low)	I2C Clock/Aux Uart Tx	Y	
Reserved						
BOOT 0	I	9	Boot 0			
Power and Ground						
V _{in}		8	V _{in}			
GND		7	GND			
Reset						
RESETN	I	10	Reset input (active low for 5 ms)		2.5V max	
LPO						
LPO	I	15	LPO input (optional)			
RF						
ANT	I/O	16	50Ω Rx/Tx antenna port			
GND		17	GND			
RX_EN		18	FEM_CTRL_2			
TX_EN		19	FEM_CTRL_1			
5G_OUT		20	RF_OUT_HB			
5G_IN		21	RF_IN_HB			
GPIO – General Purpose Input/Output						
GPIO [1]	I/O	1	General Purpose Input/Output	SPI MISO/I2S ext SD	Y	Input pull down
GPIO [2]	I/O	2	General Purpose Input/Output	SPI MOSI/I2S SD	Y	Floating
GPIO [3]	I/O	3	General Purpose Input/Output	SPI SCLK/ I2S CK	Y	Input pull down
GPIO [4]	I/O	4	General Purpose Input/Output	SPI SS/I2S WS	Y	Input pull down
GPIO [5]	I/O	5	General Purpose Input/Output	ADC 0	Y	Input pull down
GPIO [6]	I/O	6	General Purpose Input/Output	ADC 1	Y	Input pull down

2.8. Pin Placement Diagram

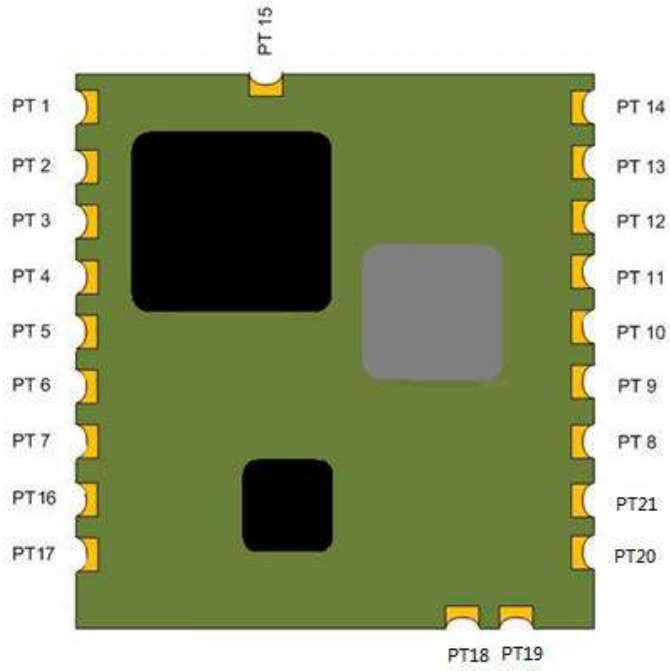

(Top View)

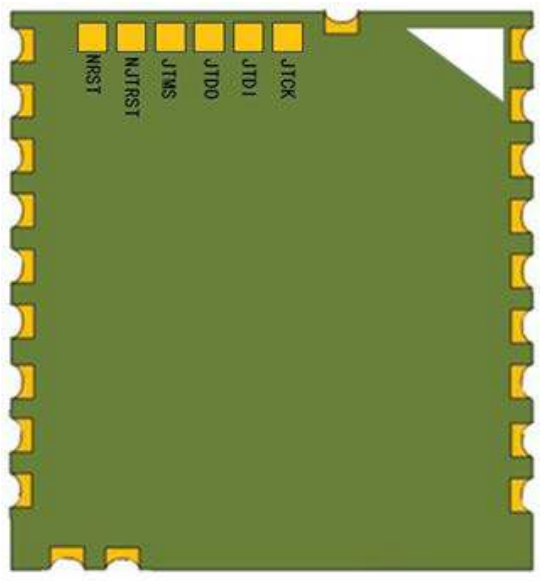

(Bottom View)

2.9. Layout Drawing

Size: 14.6 mm x 13.5 mm x 2.6 mm

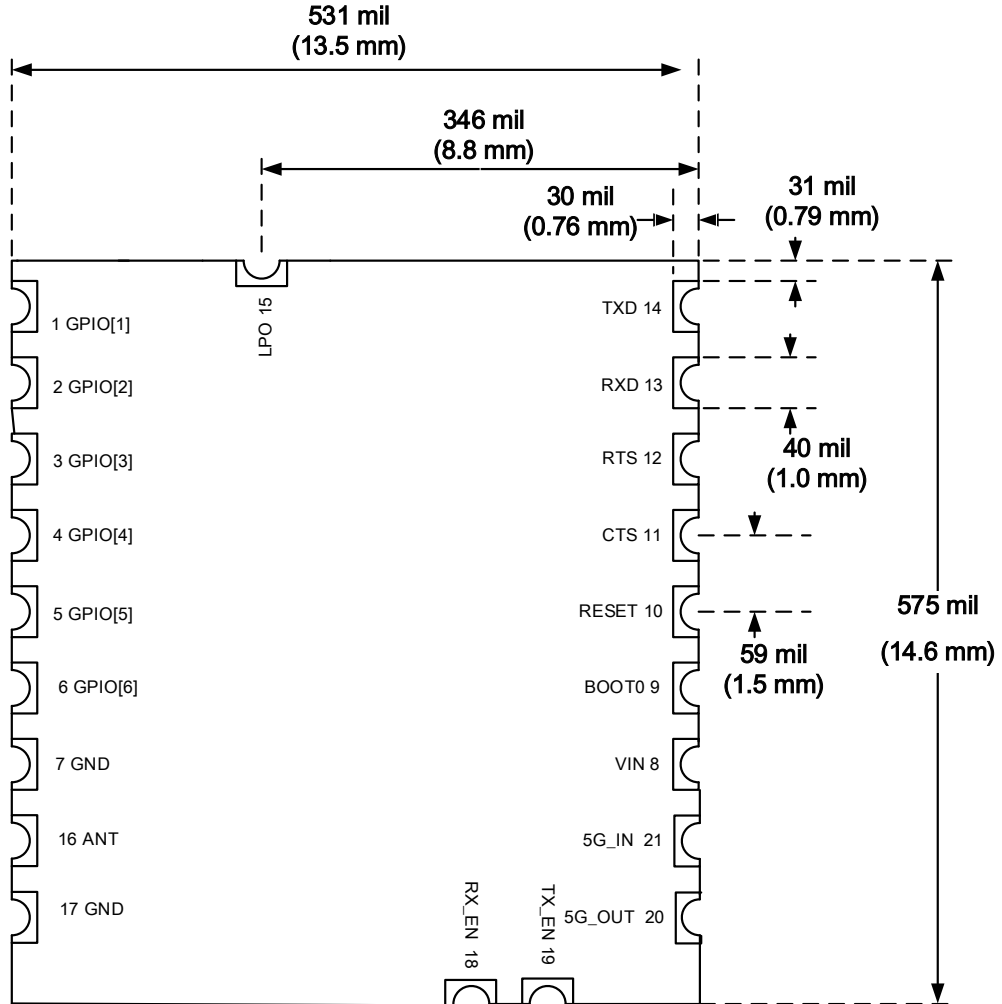

3. Hardware Design

3.1. Block Diagram

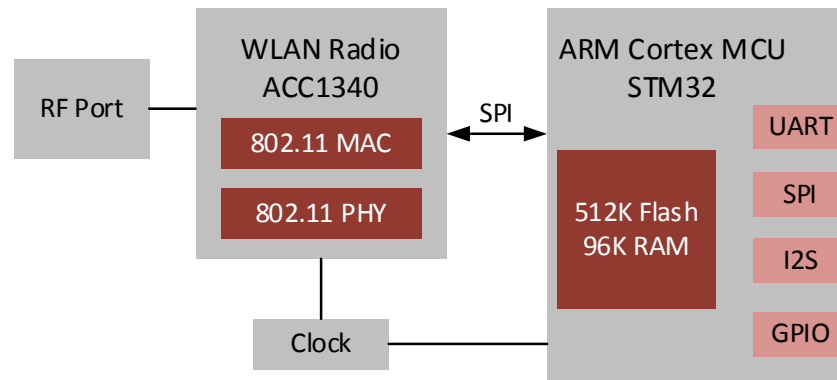

3.2. Layout

- All unused pins should be left floating; do not ground.
- All GND pins must be well grounded.
- Traces should not be routed underneath the module.

3.3. Module Reflow

The WF52 is a surface mount module supplied on a 17 pin, 6-layer PCB. The final assembly recommended reflow profiles are:

For RoHS/Pb-free applications, Sn96.5/Ag3.0/Cu0.5 solder is recommended.

- Maximum peak temperature of 230° - 240°C (below 250°C).
- Maximum rise and fall slope after liquidous of < 2°C/second.
- Maximum rise and fall slope after liquidous of < 3°C/second.
- Maximum time at liquidous of 40 – 80 seconds.

3.4. GPIO Interface

All GPIOs are capable of sinking and sourcing 4mA of I/O current.

3.5. UART Interface

The UART is compatible with the 16550 industry standard. Four signals are provided with the UART interface. The TXD and RXD pins are used for data while the CTS and RTS pins are used for flow control.

3.6. Reset Circuit

Two types of system reset circuits are detailed below.

3.6.1. External Reset Circuit

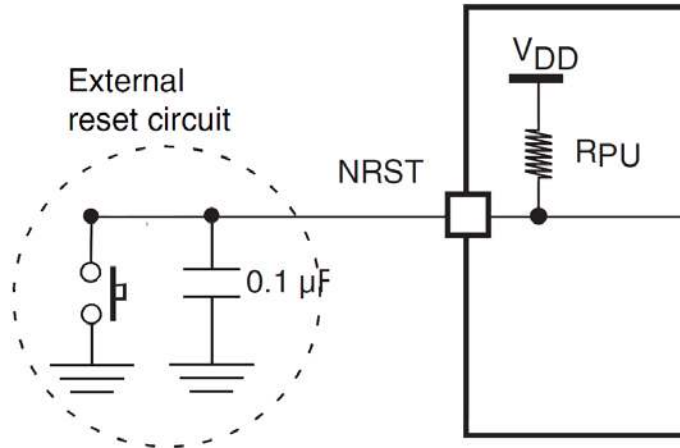

Note: R_{PU} ranges from 30K ohm to 50K ohm internally.

3.6.2. Internal Reset Circuit

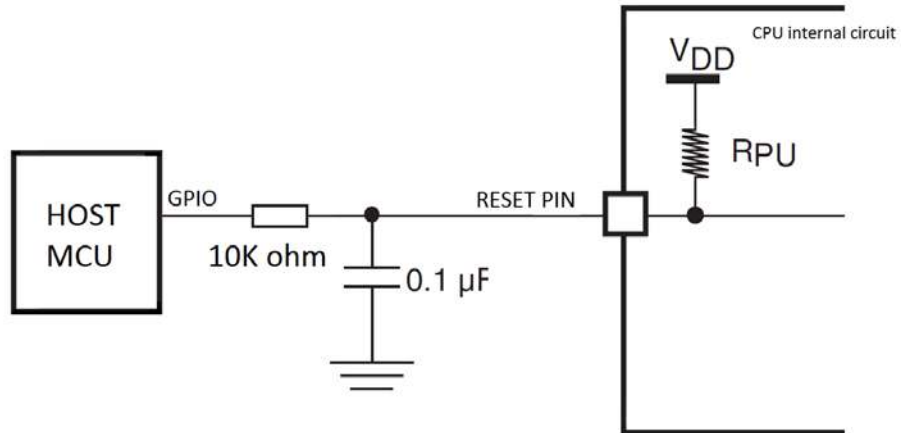

Notes:

- R_{PU} ranges from 30K ohm to 50K ohm internally.
- R_{RST} should be from 1K ohm to 10K ohm

3.7. Reference design

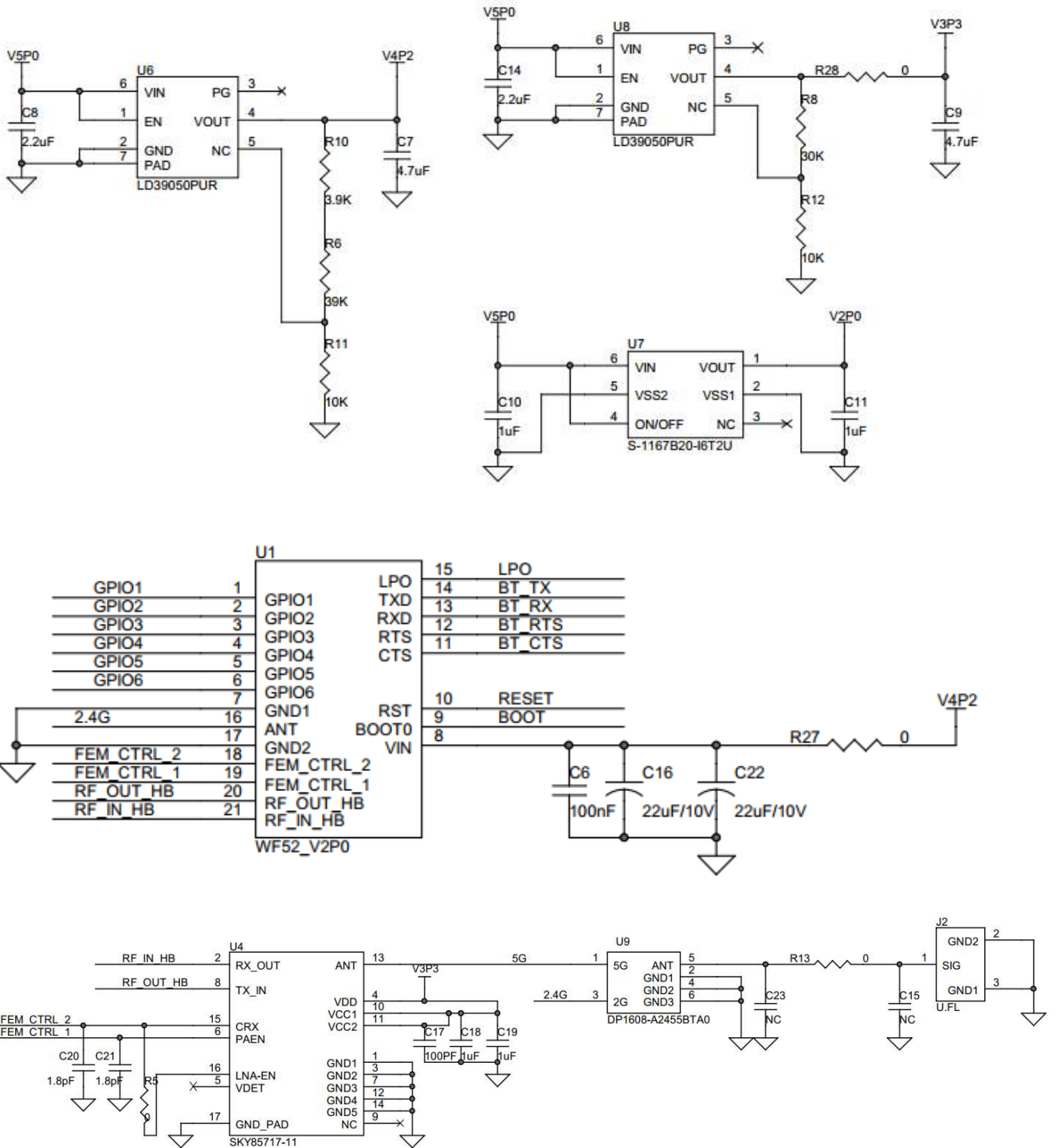

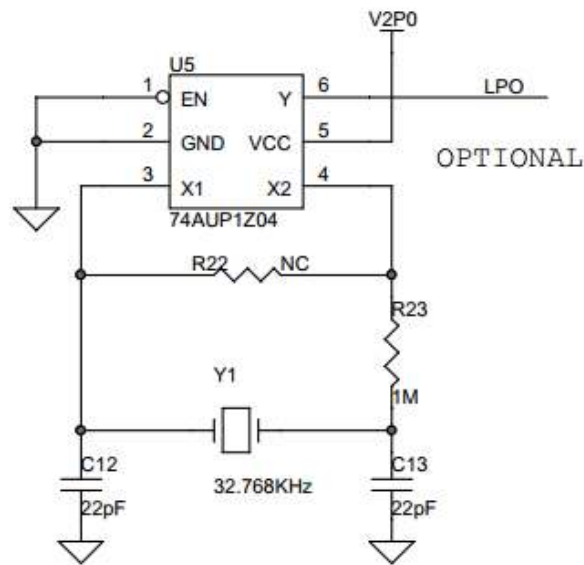
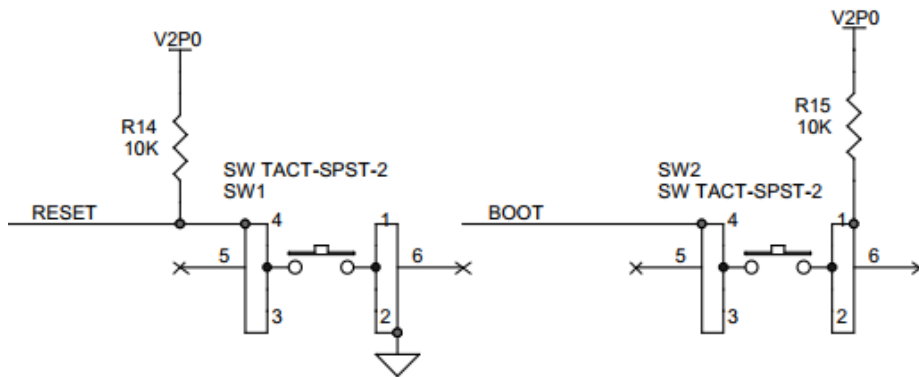

3.8. External LPO Input Circuit

The LPO input circuit is optional. The accuracy of the slow clock frequency must be 32.768 KHz ± 150 ppm.

LPO Parameters:

Frequency: 32.768 KHz

Tolerance: 150 ppm

Voltage Levels:

Low: 0.1 V

High: 2.0 V

Input Capacitance: 2.5 pF maximum

4. Regulatory Compliance

Federal Communications Commission statement:

This module has been tested and found to comply with the FCC Part15.

These limits are designed to provide reasonable protection against harmful interference in approved installations. This equipment generates, uses, and can radiate radio frequency energy and, if not installed and used in accordance the instructions, may cause harmful interference to radio communications. However, there is no guarantee that interference will not occur in a particular installation.

This device complies with part 15 of the FCC Rules. Operation is subject to the following two conditions: (1) This device may not cause harmful interference, and (2) this device must accept any interference received, including interference that may cause undesired operation.

Modifications or changes to this equipment not expressly approved by Amp'ed RF Technology may void the user's authority to operate this equipment.

The modular transmitter must be equipped with either a permanently affixed label or must be capable of electronically displaying its FCC identification number

(A) If using a permanently affixed label, the modular transmitter must be labeled with its own FCC identification number, and, if the FCC identification number is not visible when the module is installed inside another device, then the outside of the device into which the module is installed must also display a label referring to the enclosed module. This exterior label can use wording such as the following: "Contains Transmitter Module FCC ID: X3ZWFMOD9" or "Contains FCC ID: X3ZWFMOD9."

(B) If the modular transmitter uses an electronic display of the FCC identification number, the information must be readily accessible and visible on the modular transmitter or on the device in which it is installed. If the module is installed inside another device, then the outside of the device into which the module is installed must display a label referring to the enclosed module. This exterior label can use wording such as the following: "Contains FCC certified transmitter module(s)."

To satisfy FCC RF Exposure requirements for mobile and base station transmission devices, a separation distance of 20 cm or more should be maintained between the antenna of this device and persons during operation. To ensure compliance, operation at closer than this distance is not recommended. The antenna(s) used for this transmitter must not be co-located or operating in conjunction with any other antenna or transmitter.

Industry Canada statement:

Label of the end product:

The final end product must be labeled in a visible area with the following "Contains transmitter module IC: 8828A-MOD9"

This Class B digital apparatus complies with Canadian ICES-003.

Cet appareil numérique de la classe B est conforme à la norme NMB-003 du Canada.

This device complies with RSS-210 of the Industry Canada Rules. Operation is subject to the following two conditions: (1) This device may not cause harmful interference, and (2) this device must accept any interference received, including interference that may cause undesired operation.

Ce dispositif est conforme à la norme CNR-210 d'Industrie Canada applicable aux appareils radio exempts de licence. Son fonctionnement est sujet aux deux conditions suivantes: (1) le dispositif ne doit pas produire de brouillage préjudiciable, et (2) ce dispositif doit accepter tout brouillage reçu, y compris un brouillage susceptible de provoquer un fonctionnement indésirable.

4.1. Modular Approval, FCC and IC

FCC ID: X3ZWFMOD9

IC: 8828A-MOD9

In accordance with FCC Part 15, the WF52 is listed above as a Limited Modular Transmitter device.

4.2. FCC Label Instructions

The outside of final products that contain a WF52 device must display a label referring to the enclosed module. This exterior label can use wording such as the following:

Contains Transmitter Module

FCC ID: X3ZWFMOD9

IC: 8828A-MOD9

Any similar wording that expresses the same meaning may be used.

4.3. CE Label Instructions

CE 0197

5. Ordering Information

Part Name	Description
WF52	Standard version

6. Revision History

Date	Revision	Description
8-October-2015	1.0	First release
25-August-2016	1.1	Add a Bottom View in the Section 2.8
16-March-2017	1.2	Updated format, regulatory certifications, and RF characteristics.
23-November-2017	1.3	Add 5G support description
19-December-2017	1.4	Add LPO section part