

REVISIONS				
REV	DATE	DESCRIPTION	BY	APP'D
N2	22JUL2022	REVISED PER ECR-21-118222	AVN	VS

SEE DETAIL A

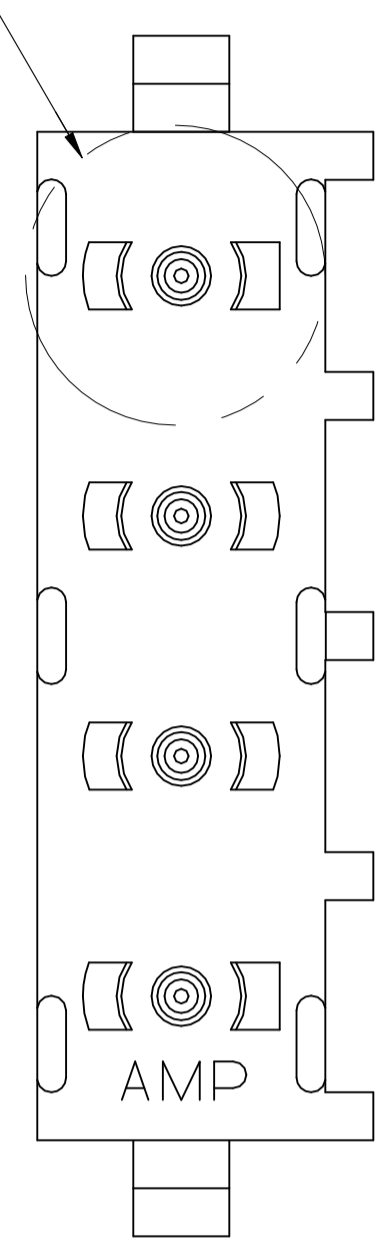

CONTACT 4 REQ'D

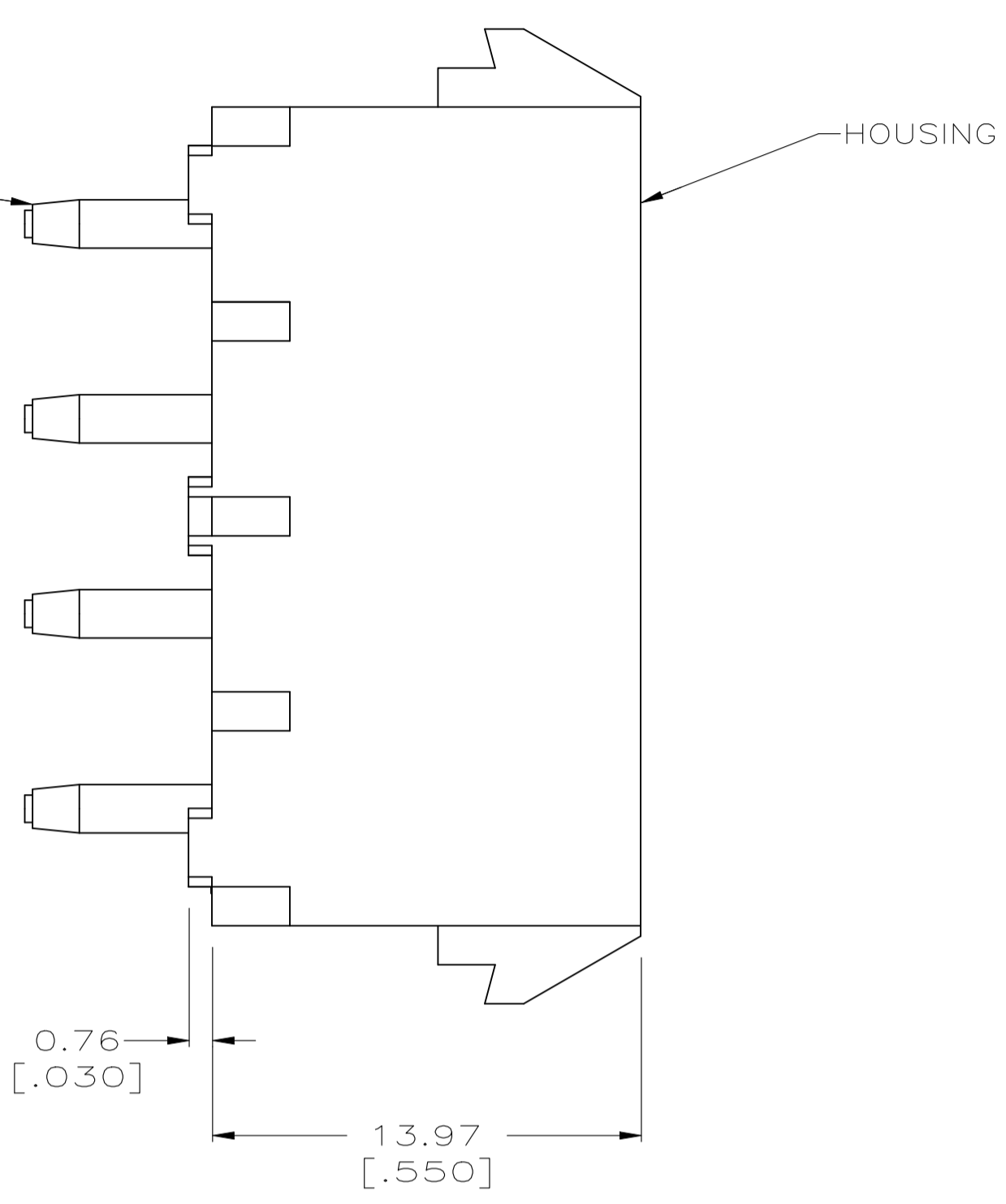

HOUSING

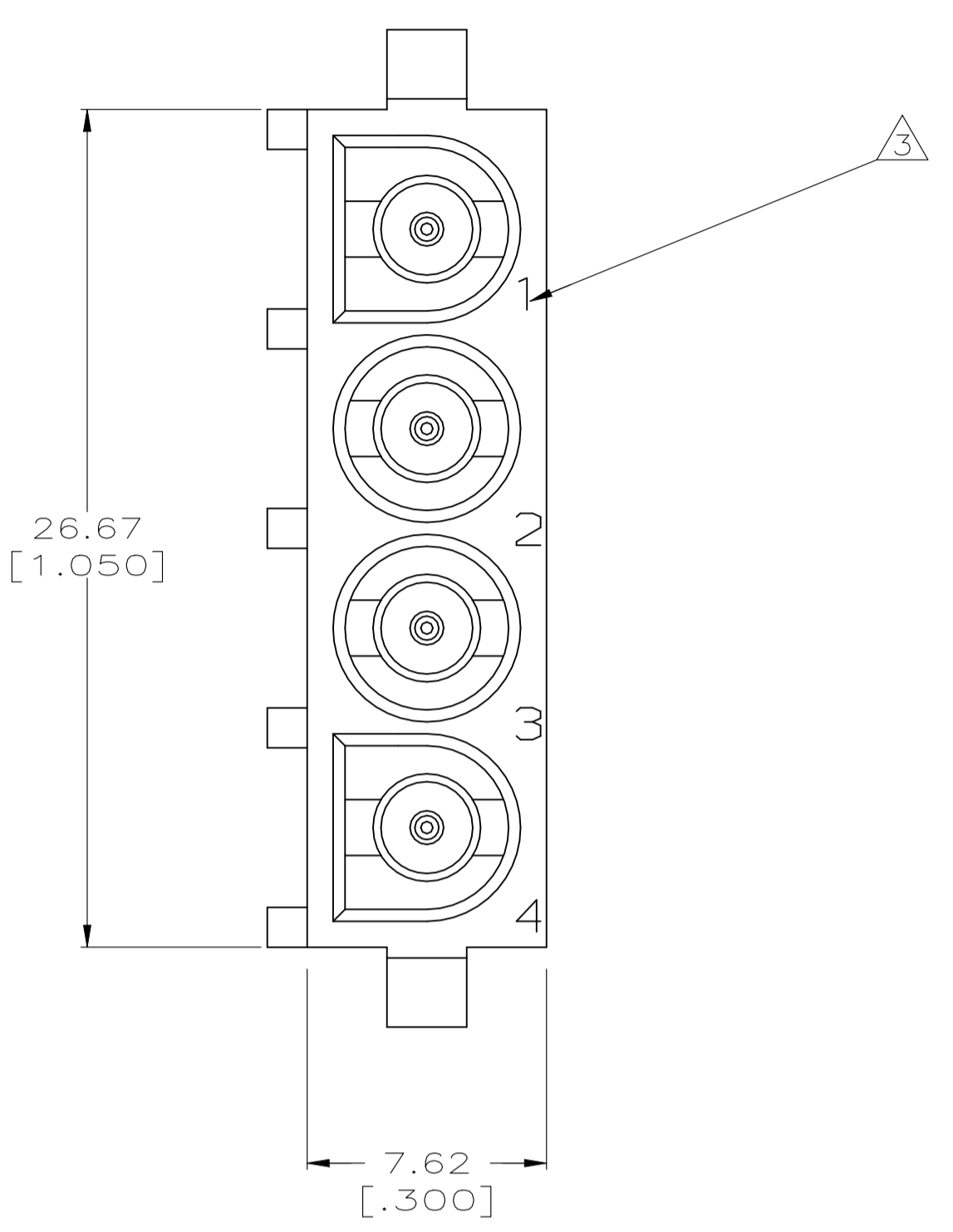

- 1 PARTS COMPLY TO AMP SOLDERABILITY SPECIFICATION 109-11-3.
- 2 CONTACT IS PLATED OVERALL WITH 0.00127 [.000050] NICKEL, THEN 0.00076 [.000030] GOLD OVER CONTACT LENGTH INDICATED AND MATTE TIN LEAD ON SOLDER TAIL END.
- 3 CIRCUIT IDENTIFICATION CHARACTERS ARE ADJACENT TO THE INDICATED CAVITIES, BUT LOCATION AND ORIENTATION MAY DIFFER FROM PRINT.
- 4 DIMENSIONS IN BRACKETS ARE IN INCHES.
- 5 DRAIN HOLES LOCATED AS SHOWN. OPTIONAL CONSTRUCTION - ALL DRAIN HOLES LOCATED 90° AS SHOWN IN DETAIL A.
- 6 CONTACT IS PLATED OVERALL WITH 0.00127 [.000050] NICKEL, THEN 0.00076 [.000030] GOLD OVER CONTACT LENGTH INDICATED AND MATTE TIN ON SOLDER TAIL END.
- 7 SUPERSEDED BY 350833-4
- 6 DIMENSIONS SHOWN REPRESENT PRODUCT IN DRY CONDITION. ADDITIONAL 2% GROWTH DUE TO END USE LOCATION MOISTURE ABSORPTION MAY OCCUR AND SHOULD BE ACCOUNTED FOR.

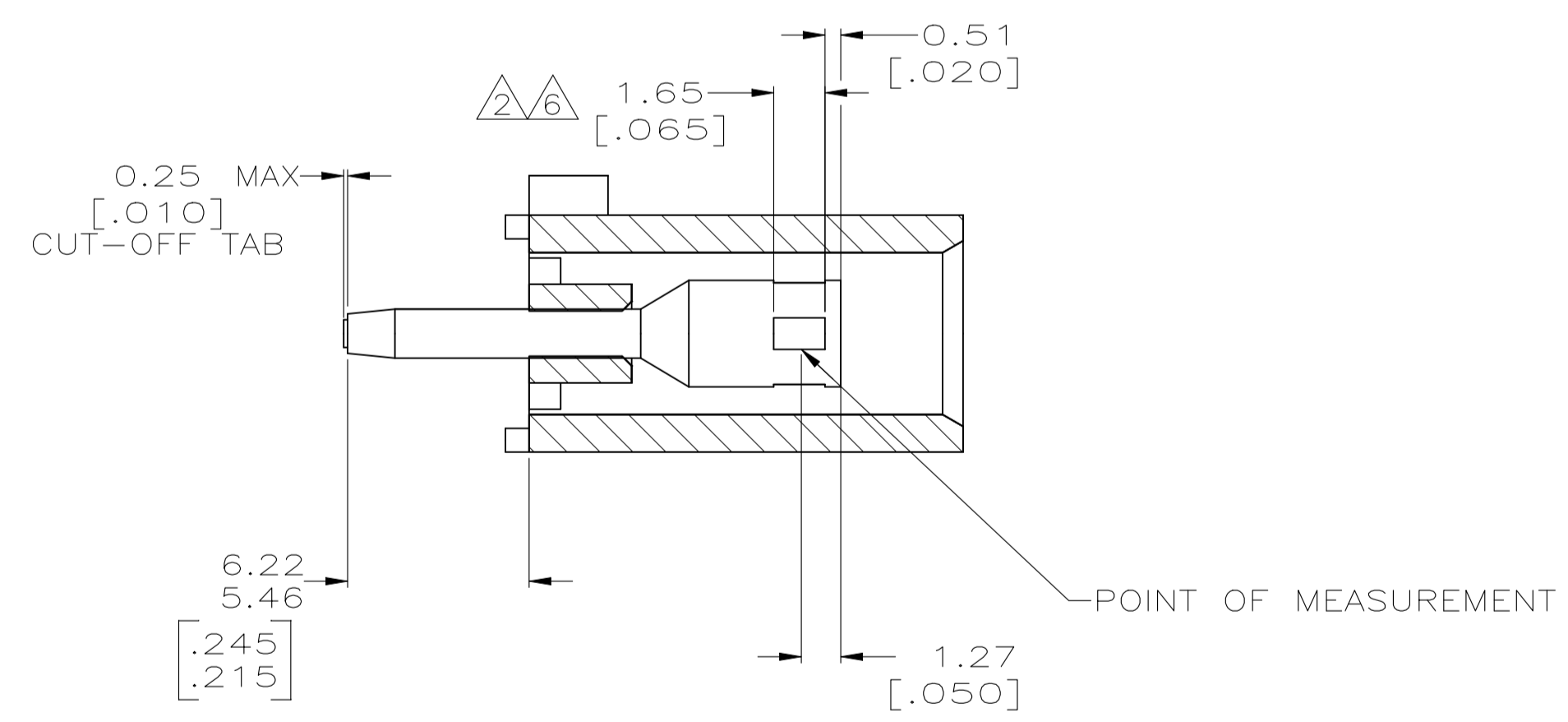

POINT OF MEASUREMENT

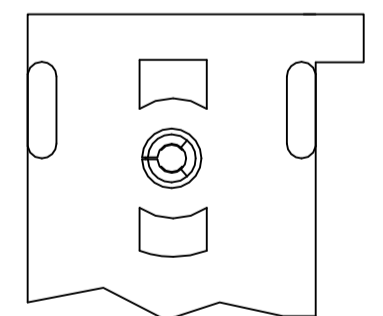

DETAIL A  
OPTIONAL CONSTRUCTION

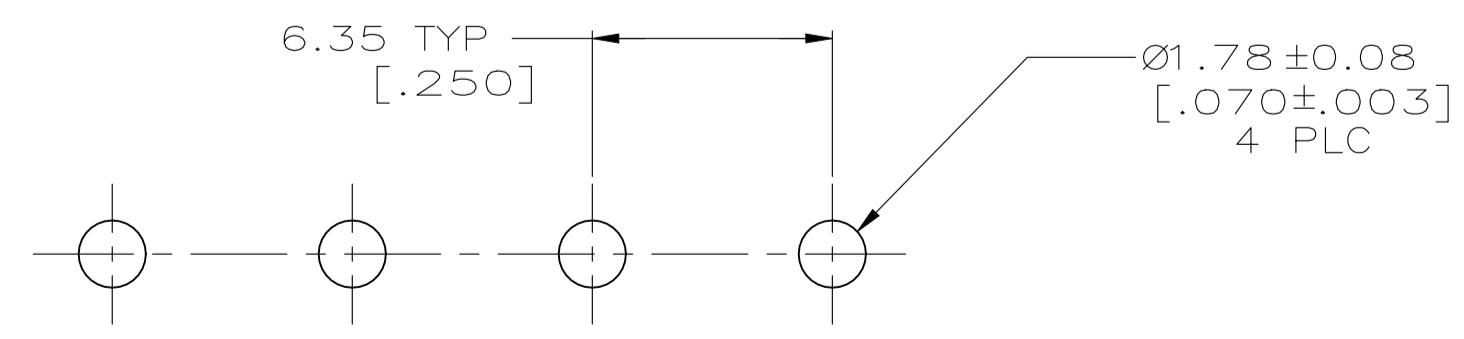

RECOMMENDED MOUNTING HOLE PATTERN FOR 3.18 [.125] THICK P.C. BOARD

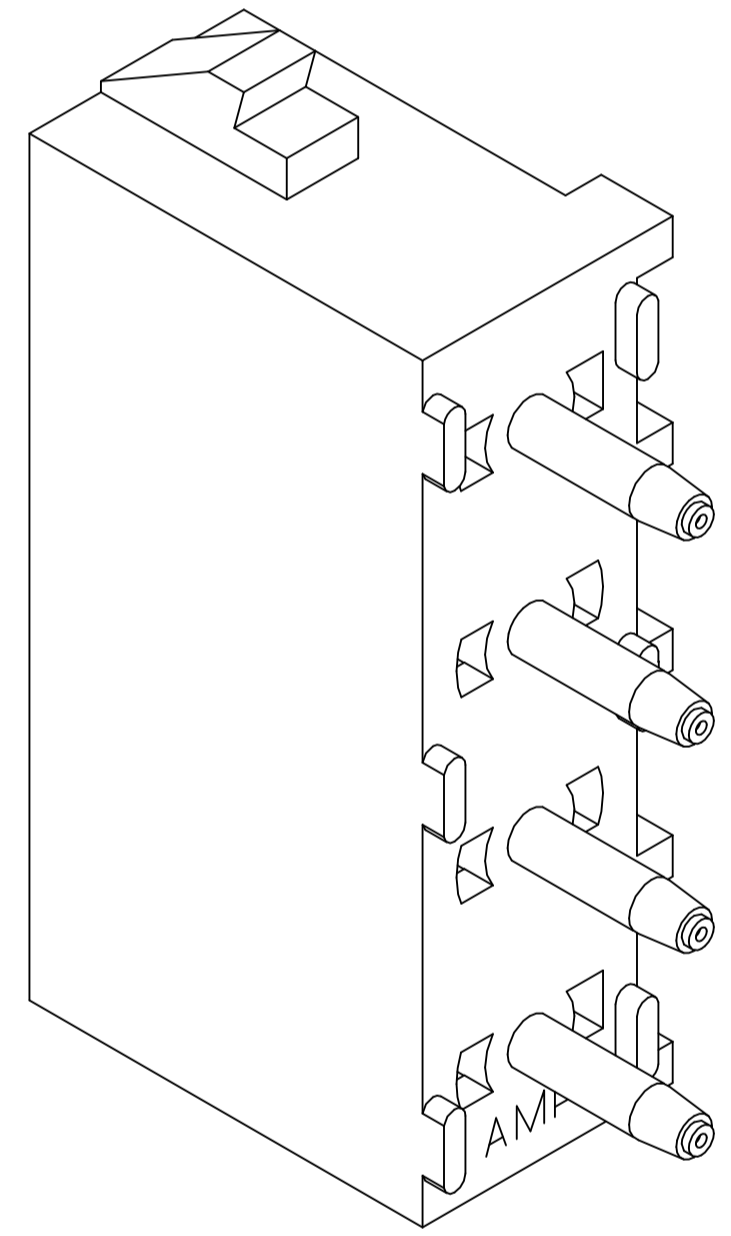

3-DIMENSIONAL MODEL  
NTS

PHOSPHOR BRONZE, GOLD	NYLON,UL94V-0,WHITE	350833-4
PHOSPHOR BRONZE, GOLD	NYLON,UL94V-0,WHITE	350833-2
PHOSPHOR BRONZE, PRE-TIN	NYLON,UL94V-0,WHITE	350833-1
CONTACT MATERIAL AND FINISH	HOUSING MATERIAL	PART NUMBER

THIS DRAWING IS A CONTROLLED DOCUMENT.		DIN R. LEWIS 10-02-98	TE Connectivity	
DIMENSIONS: mm [INCHES]		CHK R. SWING 10-02-98	NAME	
TOLERANCES UNLESS OTHERWISE SPECIFIED:		APP'D M. TRULL 10-02-98	PRODUCT SPEC	
0 PLC ± -		APPLICATION SPEC		
1 PLC ± -		SIZE		
2 PLC ± 0.13 [.005]		CAGE CODE		
3 PLC ± -		DRAWING NO		
4 PLC ± -		RESTRICTED TO		
ANGLES ± 0±30°		WEIGHT		
MATERIAL SEE TABLE		0.000000		
FINISH SEE TABLE		A1 00779 C=350833		
CUSTOMER DRAWING		SCALE 5:1 SHEET 1 of 1 REV N2		