

PART NUMBER	ITEM ①		ITEM ②	ITEM ③	ITEM ④
	HANDLE	COLOR	BODY	SPRING	STUD
108-1721-101	NYLON	WHITE	BRASS NICKEL PL .0001 MIN	NICKEL SILVER NICKEL PL .0001 MIN	BRASS BRIGHT TIN PL .0001 MIN OVER NICKEL PL .00005 MIN
108-1722-101		RED			
108-1723-101		BLACK			
108-1724-101		GREEN			
108-1725-101					
108-1726-101		ORANGE			
108-1727-101		YELLOW			
108-1728-101		BROWN			
108-1729-101					
108-1730-101		BLUE			
108-1731-101					
108-1732-101		VIOLET			
108-1733-101		GRAY			
108-1734-101					
108-1735-101					
108-1736-101					
108-1737-101					
108-1738-101					
108-1739-101					
108-1740-101					

DRAWING NO. B - 108-1721/1740-101	
0	REVISIONS
***** * REVISION NUMBER FOLLOWED BY AN ALPHA * * CHARACTER INDICATES DRAWING CLARIFI- * * CATION OR PART NUMBER ADDITION ONLY. * *****	
14a	9-14-94 R H S W T R J B ECN 42639
DIA .228+.010 -.015 WAS DIA .228 ±.005, 1.000±.020 WAS 1.000±.010 ***** * REVISION NUMBER FOLLOWED BY AN ALPHA * * CHARACTER INDICATES DRAWING CLARIFI- * * CATION OR PART NUMBER ADDITION ONLY. * *****	
14b	6-3-08 P A T R J B M J J U S J C N 6-9-08 ECN 51528

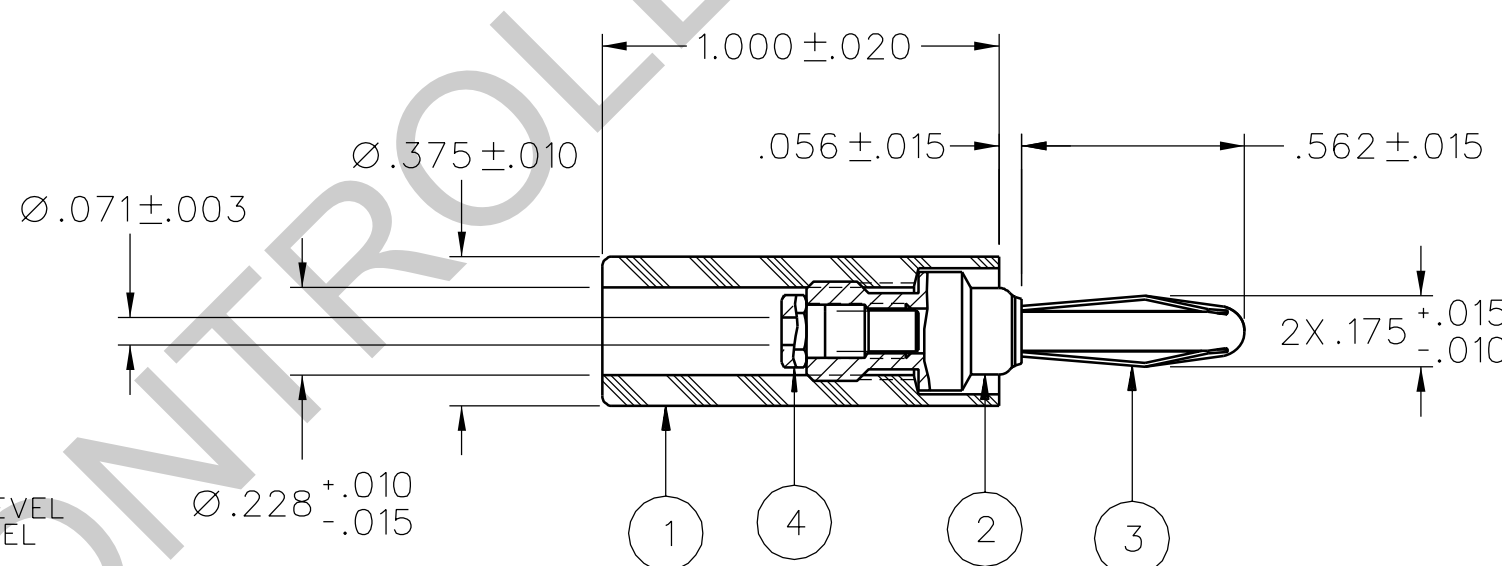

NOTES:

1. SPECIFICATIONS:

ELECTRICAL:

CURRENT RATING: 15 AMPS DC MINIMUM
 DIELECTRIC WITHSTANDING VOLTAGE: 3500 VRMS MIN AT SEA LEVEL
 RECOMMENDED WORKING VOLTAGE: 1750 VRMS MAX AT SEA LEVEL
 INSULATION RESISTANCE: 5000 MEGOHMS MIN
 CONTACT RESISTANCE: 10 MILLIOHMS MAXIMUM

MECHANICAL:

INSERTION/WITHDRAWAL FORCE: 1.0 - 12.0 POUNDS
 CONTACT SPRING RETENTION FORCE: 15 POUNDS MINIMUM
 WIRE ACCEPTABILITY: 16 AWG OR SMALLER
 WIRE ATTACHMENT: SOLDER OR FLARE AND CLAMP USING THREADED STUD
 MATING BANANA JACK DIAMETER: .166 NOMINAL
 DURABILITY: 1000 CYCLES MINIMUM

ENVIRONMENTAL:

(MEETS OR EXCEEDS THE APPLICABLE PARAGRAPH OF MIL-C-28901)
 OPERATING TEMPERATURE: -55 DEG C TO 85 DEG C.
 TEMPERATURE RISE AT RATED CURRENT: 10 DEG C MAXIMUM
 CORROSION: MIL-STD-1344, METHOD 1001, CONDITION B
 SHOCK: MIL-STD-1344, METHOD 2004, CONDITION G
 VIBRATION: MIL-STD-1344, METHOD 2005, CONDITION I
 HUMIDITY: MIL-STD-1344, METHOD 1002, CONDITION B

CUSTOMER DRAWING

THIS DRAWING TO BE INTERPRETED
PER ASME Y 14.5M - 1994

"μSTATION"

COMPANY CONFIDENTIAL

TOLERANCE UNLESS OTHERWISE SPECIFIED	DRAWN BY SWC	DATE 3-31-94	 Cinch CONNECTIVITY SOLUTIONS a bel group	Cinch Connectivity Solutions P.O. Box 1732 Waseca, MN 56093 1-800-247-8256	
DECIMALS mm	CHECKED BY TAK	DATE 9-19-94		TITLE ASSEMBLY, BANANA PLUG, INSULATED HANDLE ROUND BODY, SOLDER OR SOLDERLESS STUD	
.XX _____	APPROVED BY RJB	DATE 9-20-94	SHEET DRAWING NO. 2 OF 2 B - 108-1721/1740-101		
.XXX _____	RELEASE DATE	9-20-94	SCALE 2:1		
MATL _____	U/M INCH				
FINISH _____					