

SECTION AA-AA

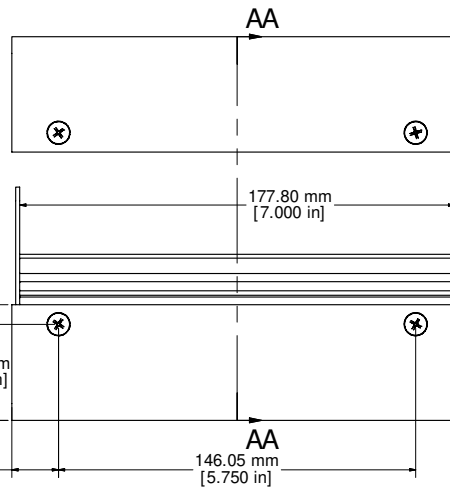

ASSEMBLY - VIEW FROM SIDE (OPEN)

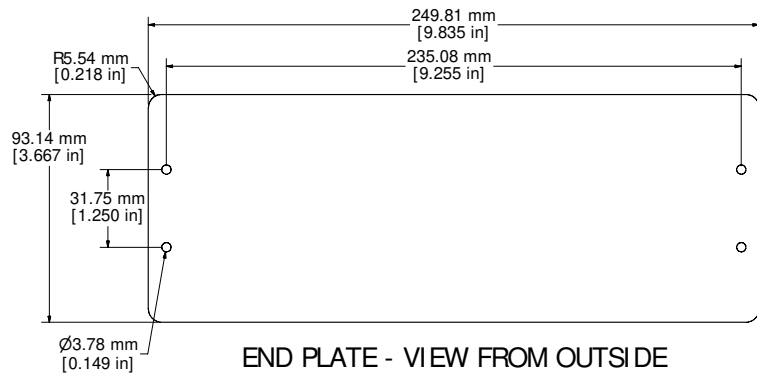
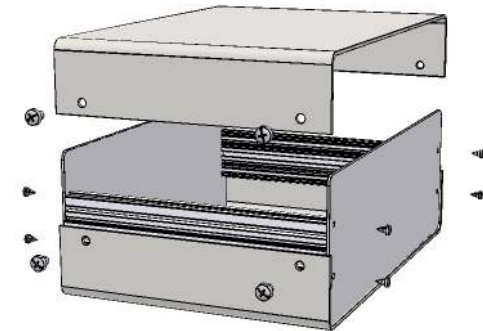

END PLATE - VIEW FROM OUTSIDE

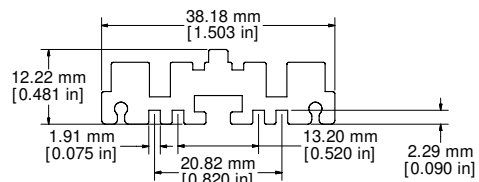

DETAIL BB

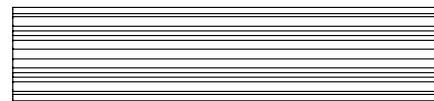
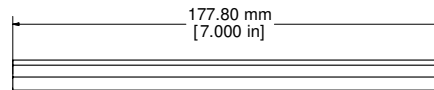
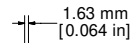

EXTRUSION - VIEW FROM INSIDE

| |
|---|
| - 12 GAUGE ALUMINUM BODY PAINTED (RAL 7032) |
| - EIGHT 6-32 NICKEL PLATED SCREWS |
| EIGHT 4-24 x 1/4" SELF-TAPPING SCREWS |
| - 0.064" THICK ALUMINUM PANELS (NATURAL ALUMINUM) |
| - FOUR SELF ADHESIVE RUBBER FEET |
| EXTRA SCREWS - 1421J6 (6-32 x 1/4 SHEET METAL SCREWS) |

Contact Factory mjm@hammondmfg.com for quotes
 Enclosures can be Factory Modified (Milling, Drilling, Printing etc.)
 Solid models of this enclosure available in STEP or IGES.



**HAMMOND
 MANUFACTURING™**

1402H

www.hammondmfg.com