



Terminal sensor adapter V2 SKU: DFR0055



Contents

- [1 Introduction](#)
- [2 Specifications](#)
- [3 Pin Out](#)
- [4 Application with DS18B20](#)
 - [4.1 Application Connection Diagram](#)
- [5 Sample Code](#)
- [6 Version history](#)

Introduction

This is universal sensor adapter V2.0, it can be accessed by digital input modules and analog input module. The module with Arduino sensor expansion board, in combination. Improvement compare with the old version, we add a 10K resistor between A & B, A & C respectively, so that you needn't to connect a addition resistor while the sensor must have a pull-up or pull-down resistor. Why need a pull-up or pull down resistor, please refer to "Understanding pull-up and pull-down resistors"

Generally speaking, this terminal provides a much easier way to connect a switch or any modules that requires pull-up/down resistor to microcontroller

Specifications

- Voltage: +5 V
- Current: <1000mA
- Size: 22x34mm

Pin Out

Understanding pull-up and pull-down resistors

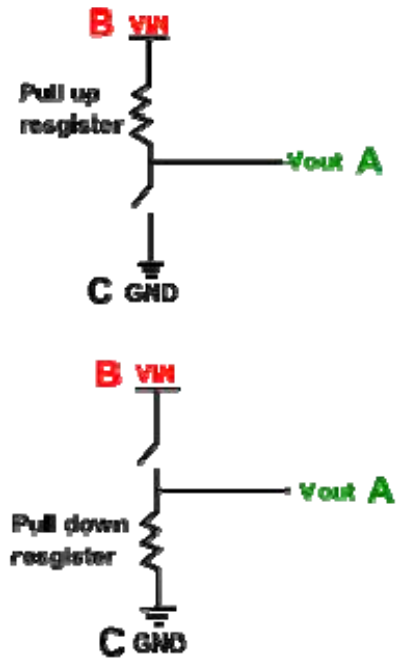
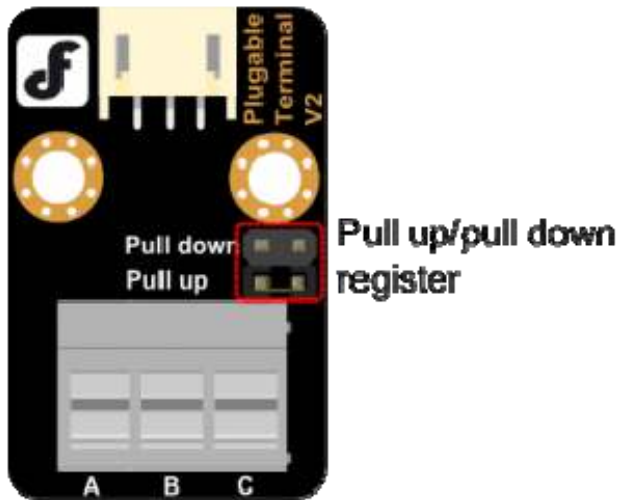

PIN	CONNECTION
A	Data Signal
B	VIN
C	GND

Application with DS18B20

When using temperature [Waterproof DS18B20 Digital temperature sensor](#), need to connect a pull-up resistor for it driven with Arduino microcontroller. The terminal sensor adapter will supply a simple and stable connection in case without soldering.

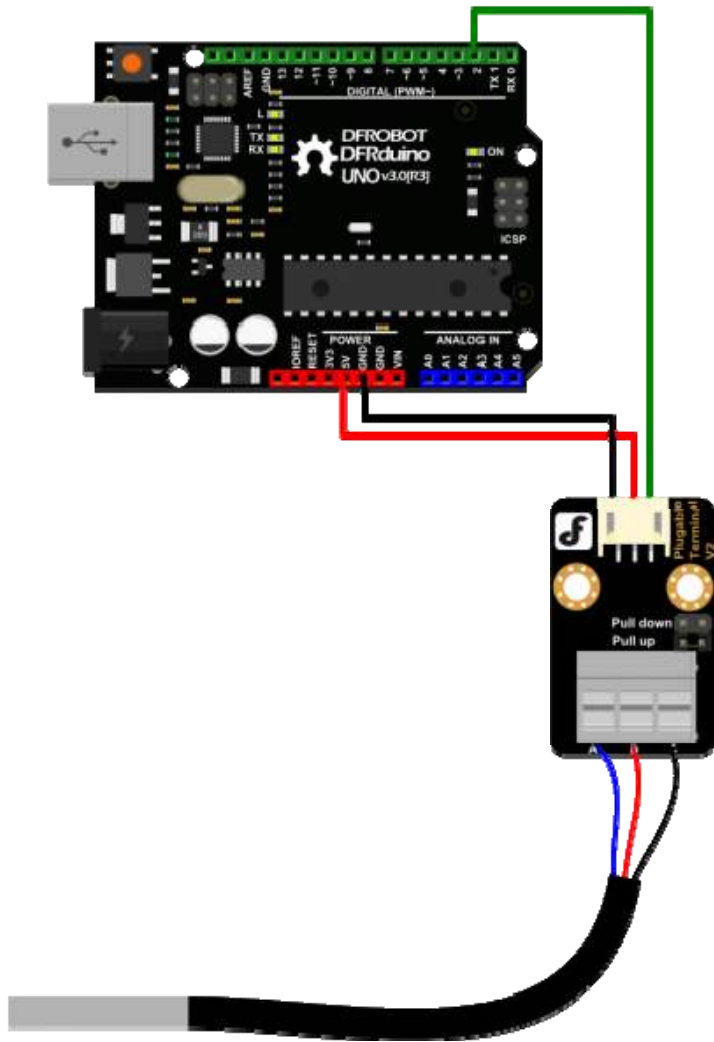

Fig2: Application CD

Sample Code

```

/*****
Insturciton:
Connection:
1.Plugable Terminal Sensor Adapter & Waterproof DS18B20 Digital Temperature
Sensor
A ----> Blue(DATA SIGNAL)
B ----> RED (VIN)
C ----> Black (GND)

```

2. Waterproof DS18B20 Digital Temperature Sensor & Arduino board

1 (A)	---->	Digital Pin2
2 (B)	---->	5V/3.3V
3 (C)	---->	GND

Setting for the Pull-up Register/Pull-down Register Selection Jumpers

When connect DS18B20 with the adapter, please choose to use the Pull-up Register Jumper

```
*****/
#include <OneWire.h>

int DS18S20_Pin = 2; //DS18S20 Signal pin on digital 2

//Temperature chip i/o
OneWire ds(DS18S20_Pin); // on digital pin 2

void setup(void) {
  Serial.begin(9600);
}

void loop(void) {
  float temperature = getTemp();
  Serial.println(temperature);

  delay(2000); //just here to slow down the output so it is easier to read
}

float getTemp(){
  //returns the temperature from one DS18S20 in DEG Celsius

  byte data[12];
  byte addr[8];
```

```
if ( !ds.search(addr)) {
    //no more sensors on chain, reset search
    Serial.println("no more sensors on chain, reset search!");
    ds.reset_search();
    return -1000;
}

if ( OneWire::crc8( addr, 7) != addr[7]) {
    Serial.println("CRC is not valid!");
    return -1000;
}

if ( addr[0] != 0x10 && addr[0] != 0x28) {
    Serial.print("Device is not recognized");
    return -1000;
}

ds.reset();
ds.select(addr);
ds.write(0x44,1); // start conversion, with parasite power on at the end

byte present = ds.reset();
ds.select(addr);
ds.write(0xBE); // Read Scratchpad

for (int i = 0; i < 9; i++) { // we need 9 bytes
    data[i] = ds.read();
}

ds.reset_search();

byte MSB = data[1];
```

```
byte LSB = data[0];

float tempRead = ((MSB << 8) | LSB); //using two's compliment
float TemperatureSum = tempRead / 16;

return TemperatureSum;

}
```

Version history

[Terminal sensor adapter V1.1](#)