

250 Watts

SDR Series



- 3.2"x 5" Footprint
- Fits 1U Applications
- Low Leakage Current
- Up to 600 W Peak Power
- Single & Dual Outputs
- Top Fan & Convection-cooled Versions
- 3 Year Warranty

Specification

Input

Input Voltage	• 90-132 VAC/180-264 VAC, auto ranging
Input Frequency	• 47-63 Hz
Input Current	• 6 A at 115 VAC, 3 A at 230 VAC
Inrush Current	• Max 70 A at 230 VAC, 35 A at 115 VAC, cold start at 25 °C
Power Factor	• EN61000-3-2, class A
Earth Leakage Current	• <500 μ A at 264 VAC/50 Hz
Input Protection	• Internal T8A/250V fuse in line

Output

Output Voltage	• See tables
Output Voltage Trim	• \pm 5% on V1 (V2 of dual output models will track by same % of adjustment)
Initial Set Accuracy	• \pm 1%
Minimum Load	• 1% on single output models, 10% on both outputs for dual models
Start Up Delay	• 1.5 s max at 120 VAC
Start Up Rise Time	• 50 ms typical
Hold Up Time	• 20 ms min at 80% of full load
Line Regulation	• \pm 0.5%
Load Regulation	• \pm 1% 1-100% load for single outputs \pm 3% V1, \pm 7% V2 for dual outputs (except 0312 & 0512 models, \pm 10% regulation on V2)
Over/Undershoot	• 5% max
Transient Response	• 5% max deviation, recovery to within 1% in 500 μ s for a 50% load change
Ripple & Noise	• 1% pk-pk (see note 3)
Overvoltage Protection	• <130% Vnom on output V1, recycle input to reset
Overtemperature Protection	• Measured internally with auto recovery
Overload Protection	• 110-140%
Short Circuit Protection	• Trip & restart (hiccup mode), auto recovery
Remote On/Off	• Requires a low signal to inhibit output (hiccup mode)
Fan Supply	• 12 VDC, 300 mA, not available on '-F' version with built-in fan

General

Efficiency	• Single output models: 3.3 V & 5 V models 70%, 12 V models 80%, all other models >83% at 230 V & full load. Dual output models: >70% at 230 V & full load
Isolation	• 3000 VAC Input to Output 1500 VAC Input to Ground 100 VDC Output to Ground
Switching Frequency	• 29 kHz typical
Power Density	• 10.4 W/in ³
Signals	• Power Good TTL HIGH within 100-500 ms and LOW \leq 1 ms before loss of regulation
MTBF	• 150 kHrs typical to MIL-HDBK-217F at 25 °C, GB

Environmental

Operating Temperature	• 0 °C to +70 °C, derate at 2.5%/ °C from +50 °C to +70 °C for single output & forced air cooled dual output models. For convection cooled dual output models, (see note 7)
Storage Temperature	• -20 °C to +85 °C
Operating Humidity	• 5-90%, non-condensing
Storage Humidity	• 5-90%, non-condensing
Cooling	• '-F' version has built-in fan, others require 16 CFM to meet forced air ratings
Operating Altitude	• 3000 m
Vibration	• 5-50 Hz, acceleration 7.35 m/s ² on X, Y and Z axis

EMC & Safety

Emissions	• EN55032 level B conducted & radiated
Harmonic Currents	• EN61000-3-2, class A
Voltage Flicker	• EN61000-3-3
ESD Immunity	• EN61000-4-2, level 3 Perf Criteria A
Radiated Immunity	• EN61000-4-3, 3 V/m Perf Criteria A
EFT/Burst	• EN61000-4-4, level 2 Perf Criteria A
Surge	• EN61000-4-5, installation class 3, Perf Criteria A
Conducted Immunity	• EN61000-4-6, 3V Perf Criteria A
Dips & Interruptions	• EN61000-4-11 30% 10 ms, 60% 100 ms, 100% 5000 ms, Perf Criteria A, B, B
Safety Approvals	• UL62368-1, CSA62368-1 via cUL, EN62368-1, CE (Meets all applicable directives), UKCA (Meets all applicable legislation)

Models and Ratings

Output Voltage	Output Power	Output Current		Ripple & Noise Pk-Pk ⁽²⁾	Model Number ^(3,4)
		Nominal	Peak ⁽¹⁾		
5 V	200 W	40.00 A	120.00 A	50 mV	SDR250AS05-F ⁽⁶⁾
9 V	225 W	25.00 A	66.67 A	90 mV	SDR250AS09-F ⁽⁶⁾
12 V	250 W	20.83 A	50.00 A	120 mV	SDR250AS12-F
15 V	250 W	16.70 A	40.00 A	150 mV	SDR250AS15-F
18 V	250 W	13.89 A	33.30 A	180 mV	SDR250AS18-F ⁽⁶⁾
24 V	250 W	10.42 A	25.00 A	240 mV	SDR250AS24-F
28 V	250 W	8.93 A	21.43 A	280 mV	SDR250AS28-F ⁽⁶⁾
36 V	250 W	6.94 A	16.67 A	360 mV	SDR250AS36-F
48 V	250 W	5.21 A	12.50 A	480 mV	SDR250AS48-F ⁽⁶⁾
54 V	250 W	4.63 A	11.10 A	540 mV	SDR250AS54-F ⁽⁶⁾
60 V	250 W	4.17 A	10.00 A	600 mV	SDR250AS60-F ⁽⁶⁾

Output Voltage	Output Power	Output Current		Ripple & Noise Pk-Pk ⁽²⁾	Model Number ^(3,4)
		Nominal	Peak ⁽¹⁾		
V1 : +3.3V	200 W	24.0 A	28.8 A	50 mV	SDR250AD0312-F ⁽⁶⁾
V2 : +12.0V		12.0 A	14.4 A	120 mV	
V1 : +3.3V	200 W	24.0 A	28.8 A	50 mV	SDR250AD0324-F ⁽⁶⁾
V2 : +24.0V		6.0 A	7.2 A	240 mV	
V1 : +5.0V	200 W	24.0 A	28.8 A	50 mV	SDR250AD0512-F ⁽⁶⁾
V2 : +12.0V		12.0 A	14.4 A	120 mV	
V1 : +5.0V	200 W	24.0 A	28.8 A	50 mV	SDR250AD0524-F ⁽⁶⁾
V2 : +24.0V		6.0 A	7.2 A	240 mV	
V1 : +5.0V	200 W	24.0 A	28.8 A	50 mV	SDR250AD0548-F ⁽⁶⁾
V2 : +48.0V		3.0 A	3.6 A	480 mV	
V1 : +12.0V	250 W	12.0 A	14.4 A	120 mV	SDR250AD1224-F
V2 : +24.0V		6.0 A	7.2 A	240 mV	

Notes

1. Peak load can be taken for 500 μ s. Average power not to exceed max power.
2. Ripple & noise is measured using a 0.1 μ F ceramic capacitor in parallel with 22 μ F electrolytic and 20 MHz bandwidth.
3. Add suffix 'D' for optional output terminal block except the 5 V and 9 V output models which are only available with output terminal blocks.⁽⁶⁾
4. Add suffix 'E' for optional input terminal block.⁽⁶⁾
5. Available for OEM quantities, contact Sales.

Mechanical Details

Enclosed with top fan (option -F)

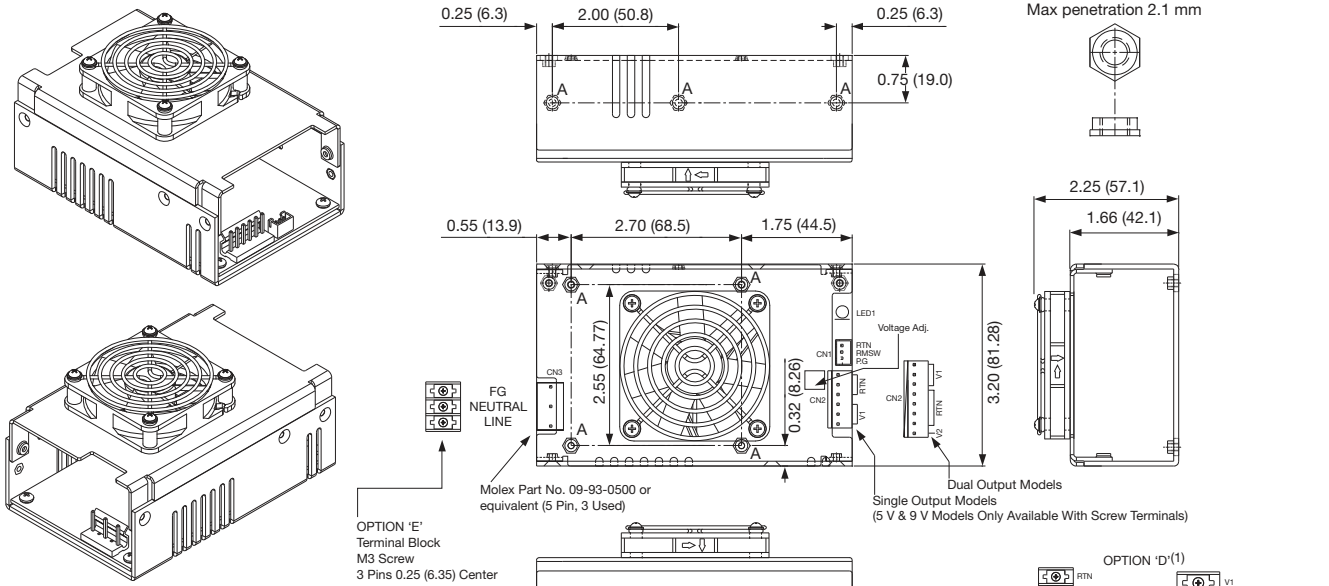

Notes

1. All dimensions are in inches (mm). Tolerance: ± 0.012 (± 0.3)
2. Weight: 0.95 lbs (430 g)
3. Signal connector CN1 mates with JST XHP-3 or equivalent & crimp terminals SXH-002T-P0.6.
4. Input: Molex No. 09-93-0500, crimp terminals Molex series 6838.
5. Output: Molex No. 09-93-0600 for 12 V to 60 V single output models, 09-93-0800 for dual output models, crimp terminals Molex series 6838.
6. Terminal block for 5 V to 9 V single output models.

Mechanical Details

Output Voltage	Forced-cooled		Convection-cooled		Peak Current ⁽²⁾	Ripple & Noise Pk-Pk ⁽³⁾	Model Number ^(1,4,5,6)
	Output Power	Output Current	Output Power	Output Current			
5 V	200 W	40.00 A	100 W	20.00 A	120.00 A	50 mV	SDR250AS05 ⁽⁶⁾
9 V	225 W	25.00 A	121 W	13.50 A	66.67 A	90 mV	SDR250AS09 ⁽⁶⁾
12 V	250 W	20.83 A	135 W	11.23 A	50.00 A	120 mV	SDR250AS12
15 V	250 W	16.70 A	135 W	9.00 A	40.00 A	150 mV	SDR250AS15
18 V	250 W	13.89 A	135 W	7.50 A	33.30 A	180 mV	SDR250AS18 ⁽⁶⁾
24 V	250 W	10.42 A	135 W	5.63 A	25.00 A	240 mV	SDR250AS24
28 V	250 W	8.93 A	135 W	4.82 A	21.43 A	330 mV	SDR250AS28 ⁽⁶⁾
36 V	250 W	6.94 A	135 W	3.75 A	16.67 A	360 mV	SDR250AS36
48 V	250 W	5.21 A	135 W	2.81 A	12.30 A	480 mV	SDR250AS48 ⁽⁶⁾
54 V	250 W	4.63 A	135 W	2.50 A	11.10 A	540 mV	SDR250AS54 ⁽⁶⁾
60 V	250 W	4.17 A	135 W	2.25 A	10.00 A	600 mV	SDR250AS60 ⁽⁶⁾

Output Voltage	Forced-cooled		Convection-cooled		Peak Current ⁽²⁾	Ripple & Noise Pk-Pk ⁽³⁾	Model Number ^(1,4,5,6,7)
	Output Power	Output Current	Output Power	Output Current			
V1 : +3.3 V	200 W	24.0 A	100 W	12.0 A	28.8 A	50 mV	SDR250AD0312 ⁽⁶⁾
V2 : +12.0 V		12.0 A		7.0 A	14.4 A	120 mV	
V1 : +3.3 V	200 W	24.0 A	100 W	12.0 A	28.8 A	50 mV	SDR250AD0324 ⁽⁶⁾
V2 : +24.0 V		6.0 A		4.0 A	7.2 A	240 mV	
V1 : +5.0 V	200 W	24.0 A	100 W	12.0 A	28.8 A	50 mV	SDR250AD0512 ⁽⁶⁾
V2 : +12.0 V		12.0 A		7.0 A	14.4 A	120 mV	
V1 : +5.0 V	200 W	24.0 A	100 W	12.0 A	28.8 A	50 mV	SDR250AD0524 ⁽⁶⁾
V2 : +24.0 V		6.0 A		4.0 A	7.2 A	240 mV	
V1 : +5.0 V	200 W	24.0 A	100 W	12.0 A	28.8 A	50 mV	SDR250AD0548 ⁽⁶⁾
V2 : +48.0 V		3.0 A		2.0 A	3.6 A	480 mV	
V1 : +12.0 V	250 W	12.0 A	135 W	7.0 A	14.4 A	120 mV	SDR250AD1224
V2 : +24.0 V		6.0 A		4.0 A	7.2 A	240 mV	

Notes

1. Add suffix 'L' to model number for optional 500 μA leakage current.⁽⁸⁾
2. Peak load can be taken for 500 μs. Average power not to exceed max power.
3. Ripple & noise is measured using a 0.1 μF ceramic capacitor in parallel with 22 μF electrolytic and 20 MHz bandwidth.
4. For optional vented cover add suffix '-C' to model number.
5. Add suffix '-D' for optional output terminal block except the 5 V and 9 V output models which are only available with output terminal blocks.⁽⁶⁾
6. Add suffix '-E' for optional input terminal block.⁽⁸⁾
7. Operating temperature - 0 °C to +60 °C, derate at 5%/ °C from 50 °C to 60 °C for convection cooled dual output models.
8. Available for OEM quantities, contact Sales.

Mechanical Details

U-Channel

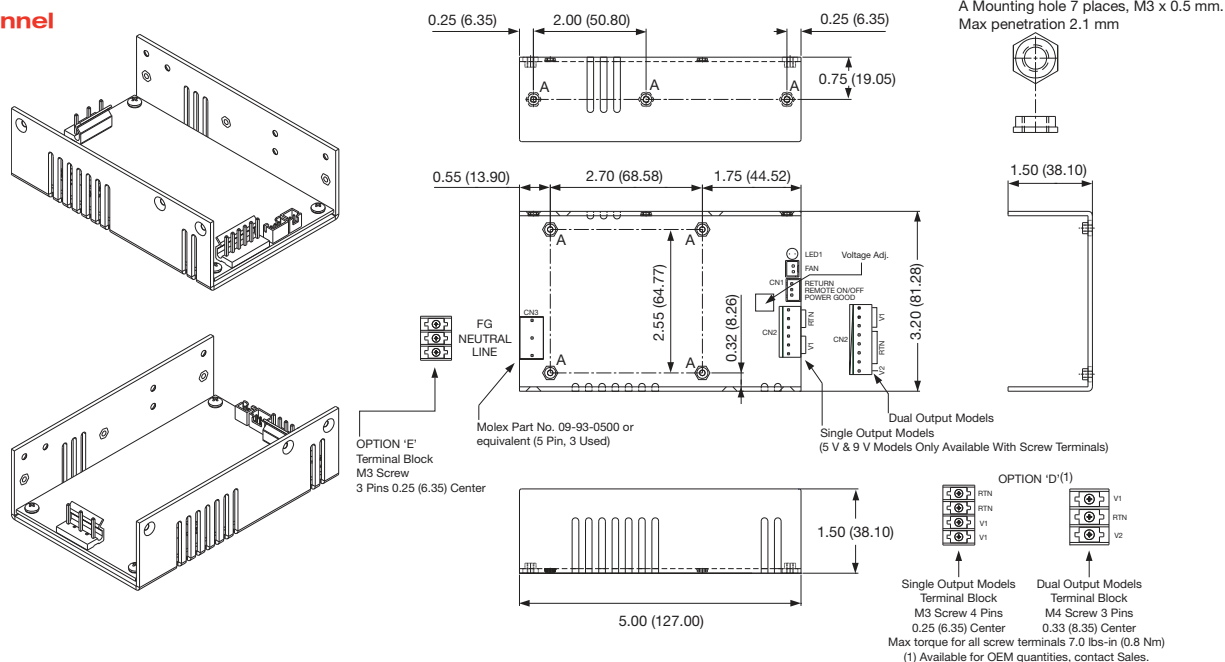

Notes

1. All dimensions are in inches (mm). Tolerance: ±0.012 (±0.3)
2. Weight: 0.88 lbs (400 g)
3. Signal connector CN1 mates with JST XHP-3 or equivalent & crimp terminals SXH-002T-P0.6.
4. Fan connector mates with JST XHP-2 or equivalent & crimp terminals.
5. Input: Molex No. 09-93-0500, crimp terminals Molex series 6838.
6. Output: Molex No. 09-93-0600 for 12 V to 60 V single output models, 09-93-0800 for dual output models, crimp terminals Molex series 6838.
7. Terminal block for 5 V to 9 V single output models.

Mechanical Details

U-Channel with cover (Option 4C)

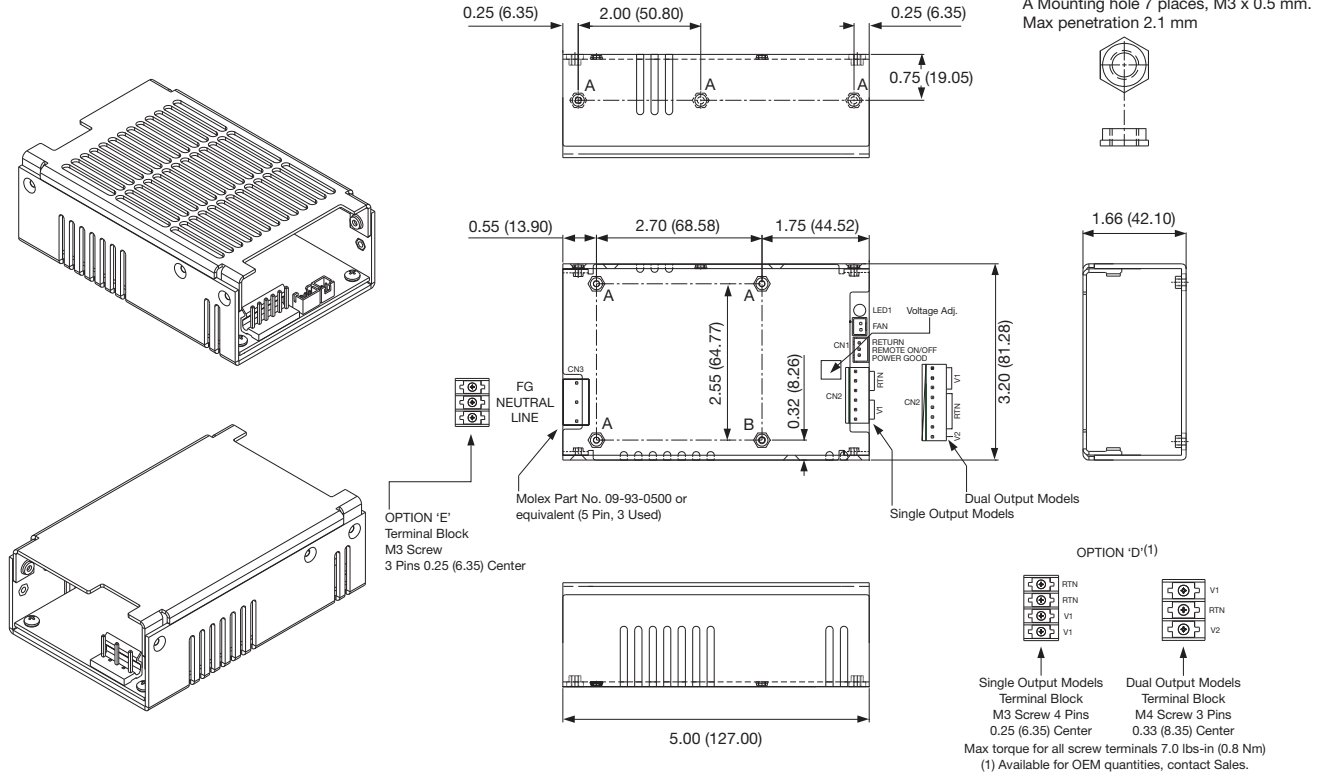

Notes

1. All dimensions are in inches (mm). Tolerance: ± 0.012 (± 0.3)
2. Weight: 0.93 lbs (420 g)
3. Signal connector CN1 mates with JST XHP-3 or equivalent & crimp terminals SXH-002T-P0.6.
4. Fan connector mates with JST XHP-2 or equivalent & crimp terminals.
5. Input: Molex No. 09-93-0500, crimp terminals Molex series 6838.
6. Output: Molex No. 09-93-0600 for 12 V to 60 V single output models, 09-93-0800 for dual output models, crimp terminals Molex series 6838.
7. Terminal block for 5 V to 9 V single output models

Application Notes

Remote On/Off

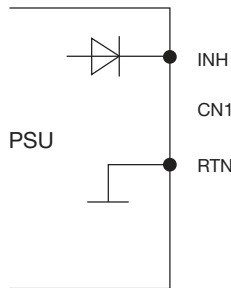

Note:

1. Applying $< 0.3V$ or short between pins 2 and 1 turns the output OFF.
2. Applying $> 4.5V$ or open circuit between pins 2 and 1 turns output ON.
3. The output will enter hiccup mode. Recommended maximum time is 3 minutes.

Power Good

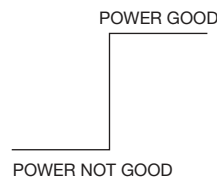
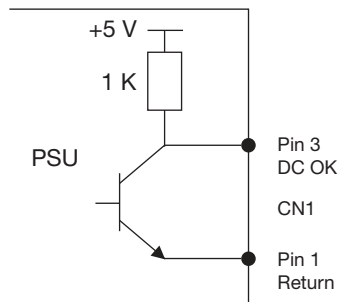

Sink current = 6 mA
Source current = 1 mA