

NOTES:

1. MATERIALS: HOUSING - LIQUID CRYSTAL POLYMER (LCP), GLASS-FILLED, UL94V-0, COLOR: BLACK, TERMINAL - PHOSPHOR BRONZE.
2. FINISHES: SELECTIVE GOLD (Au) IN CONTACT AREA, SELECTIVE TIN (Sn) IN TAIL AREA; NICKEL (Ni) OVERALL.
3. THIS PART CONFORMS TO MOLEX PRODUCT SPECIFICATION PS-73670-9999.
4. FOR MIXED CONTACT MATING LENGTHS, CONSULT FACTORY FOR AVAILABILITY.
5. PACKAGE PER PK-70873-0818.
6. PARTS MARKED WITH PART NUMBER AND DATE CODE, ON EITHER SIDE, APPROXIMATELY WHERE SHOWN.

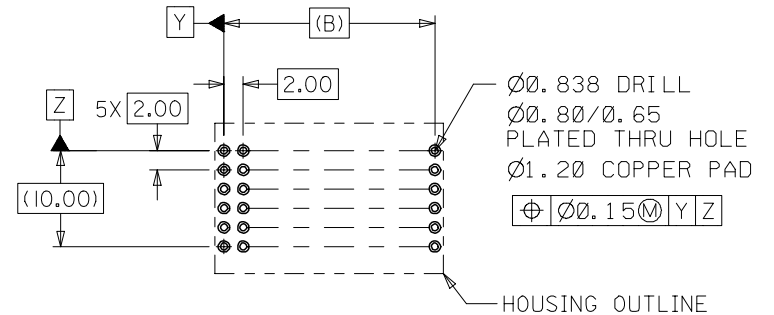
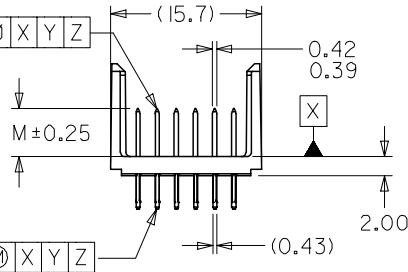
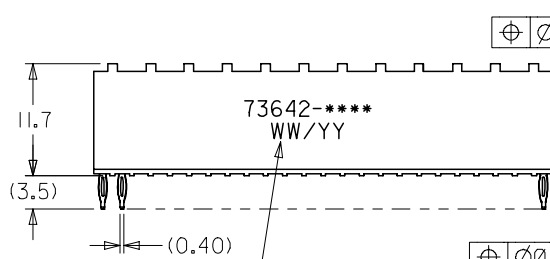
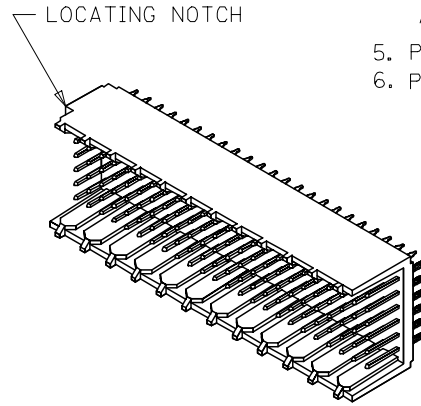
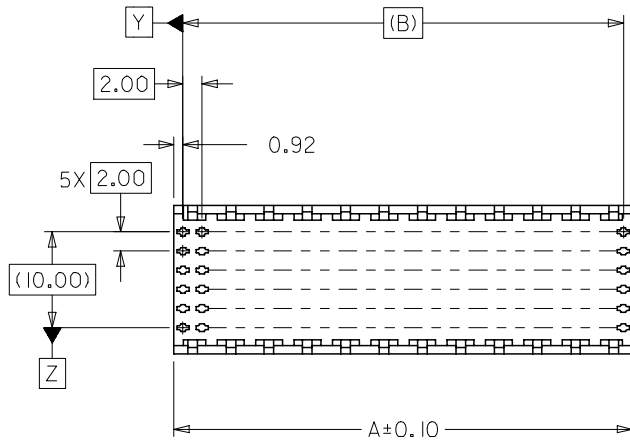

PCB LAYOUT: COMPONENT SIDE
RECOMMENDED PCB THICKNESS: 2.50 MIN.

Ø0.838 DRILL
Ø0.80/Ø.65
PLATED THRU HOLE
Ø1.20 COPPER PAD
⊕ Ø0.15Ⓜ Y Z

| | | | | | | | | | |
|---|-------------------------------|---------------------------------------|---|----------------------------|----------------------------|------------------------------|---|------------------------|--|
| INITIAL RELEASE EC NO: UCP2006-1564 DRW: JJONIAK 2006/01/31 CHKD: JBINGHAM 2006/01/31 APPR: CBI XLER 2006/02/02 | QUALITY SYMBOLS ▽=0 ▽=0 | GENERAL TOLERANCES (UNLESS SPECIFIED) | | DIMENSION STYLE MM ONLY | | SCALE 2:1 | DESIGN UNITS METRIC | THIRD ANGLE PROJECTION | |
| | | | mm | INCH | DRAWN BY JJONIAK | DATE 2005/11/01 | TITLE SALES ASSEMBLY LEADFREE HDM BACKPLANE MODULE OPEN END OPTION | | |
| | | 4 PLACES | ± --- | ± --- | CHECKED BY JBINGHAM | DATE 2005/11/01 | | | |
| | | 3 PLACES | ± --- | ± --- | APPROVED BY JBINGHAM | DATE 2005/11/01 | MOLEX INCORPORATED | | |
| 2 PLACES | ± --- | ± --- | ANGULAR ±1/2° | | MATERIAL NO. SEE PAGE 2 | DOCUMENT NO. SD-73642-003 | | | |
| 1 PLACE | ± --- | ± --- | DRAFT WHERE APPLICABLE MUST REMAIN WITHIN DIMENSIONS | | | | | | |

10 9 8 7 6 5 4 3 2 1

| MATERIAL NUMBER | NUMBER OF SIGNAL CONTACTS | PLATING | DIM "A" | DIM "B" | DIM "M" |
|-----------------|---------------------------|------------------------------|---------|---------|---------|
| 73642-2009 | 72 | SELECTIVE GOLD/SELECTIVE TIN | 23.84 | 22.00 | 5.00 |
| 73642-2109 | 72 | SELECTIVE GOLD/SELECTIVE TIN | 23.84 | 22.00 | 5.50 |
| 73642-2209 | 72 | SELECTIVE GOLD/SELECTIVE TIN | 23.84 | 22.00 | 6.00 |
| 73642-3009 | 144 | SELECTIVE GOLD/SELECTIVE TIN | 47.84 | 46.00 | 5.00 |
| 73642-3109 | 144 | SELECTIVE GOLD/SELECTIVE TIN | 47.84 | 46.00 | 5.50 |
| 73642-3209 | 144 | SELECTIVE GOLD/SELECTIVE TIN | 47.84 | 46.00 | 6.00 |

| INITIAL RELEASE EC NO: UCP2006-1564 DRWN: JJONIAK 2006/01/31 CHKD: JBINGHAM 2006/01/31 APPR: CBI XLER 2006/02/02 | DESCRIPTION REV A | QUALITY SYMBOLS ▽=0 ▽=0 | GENERAL TOLERANCES (UNLESS SPECIFIED) | | DIMENSION STYLE MM ONLY | SCALE --- | DESIGN UNITS METRIC | THIRD ANGLE PROJECTION | | | | | | | | | | | | | | | | |
|--|--|-------------------------------|---|---------------------|----------------------------|--------------|------------------------|------------------------|-------|----------|-------|-------|----------|-------|-------|---------|-------|-------|---------------------|--------------------|---|--|--|--|
| | | | <table border="1"> <thead> <tr> <th></th> <th>mm</th> <th>INCH</th> </tr> </thead> <tbody> <tr> <td>4 PLACES</td> <td>± ---</td> <td>± ---</td> </tr> <tr> <td>3 PLACES</td> <td>± ---</td> <td>± ---</td> </tr> <tr> <td>2 PLACES</td> <td>± ---</td> <td>± ---</td> </tr> <tr> <td>1 PLACE</td> <td>± ---</td> <td>± ---</td> </tr> </tbody> </table> | | mm | INCH | 4 PLACES | ± --- | ± --- | 3 PLACES | ± --- | ± --- | 2 PLACES | ± --- | ± --- | 1 PLACE | ± --- | ± --- | DRAWN BY JJONIAK | DATE 2005/11/01 | TITLE SALES ASSEMBLY LEADFREE HDM BACKPLANE MODULE OPEN END OPTION | | | |
| | | | mm | INCH | | | | | | | | | | | | | | | | | | | | |
| | | 4 PLACES | ± --- | ± --- | | | | | | | | | | | | | | | | | | | | |
| 3 PLACES | ± --- | ± --- | | | | | | | | | | | | | | | | | | | | | | |
| 2 PLACES | ± --- | ± --- | | | | | | | | | | | | | | | | | | | | | | |
| 1 PLACE | ± --- | ± --- | | | | | | | | | | | | | | | | | | | | | | |
| | CHECKED BY JBINGHAM | DATE 2005/11/01 | | | | | | | | | | | | | | | | | | | | | | |
| | APPROVED BY JBINGHAM | DATE 2005/11/01 | ANGULAR ±1/2° | | MOLEX INCORPORATED | | | | | | | | | | | | | | | | | | | |
| | DRAFT WHERE APPLICABLE MUST REMAIN WITHIN DIMENSIONS | MATERIAL NO. SEE CHART | DOCUMENT NO. SD-73642-003 | SHEET NO. 2 OF 2 | | | | | | | | | | | | | | | | | | | | |

9 8 7 6 5 4 3 2 1