

REV.	DATE	ECR NO.	DESCRIPTION
NC	08/08/02	-	INITIAL RELEASE
A	10/03/07	-	REVISE CABLE CALL OUT, UPDATE DRAWING FORMAT
B	03/16/09	-	REVISE PART DESCRIPTION

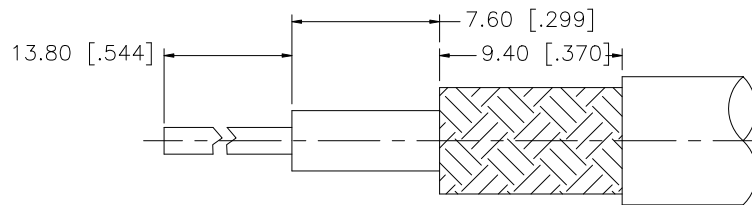

RECOMMENDED CABLE STRIPPING DIM'S

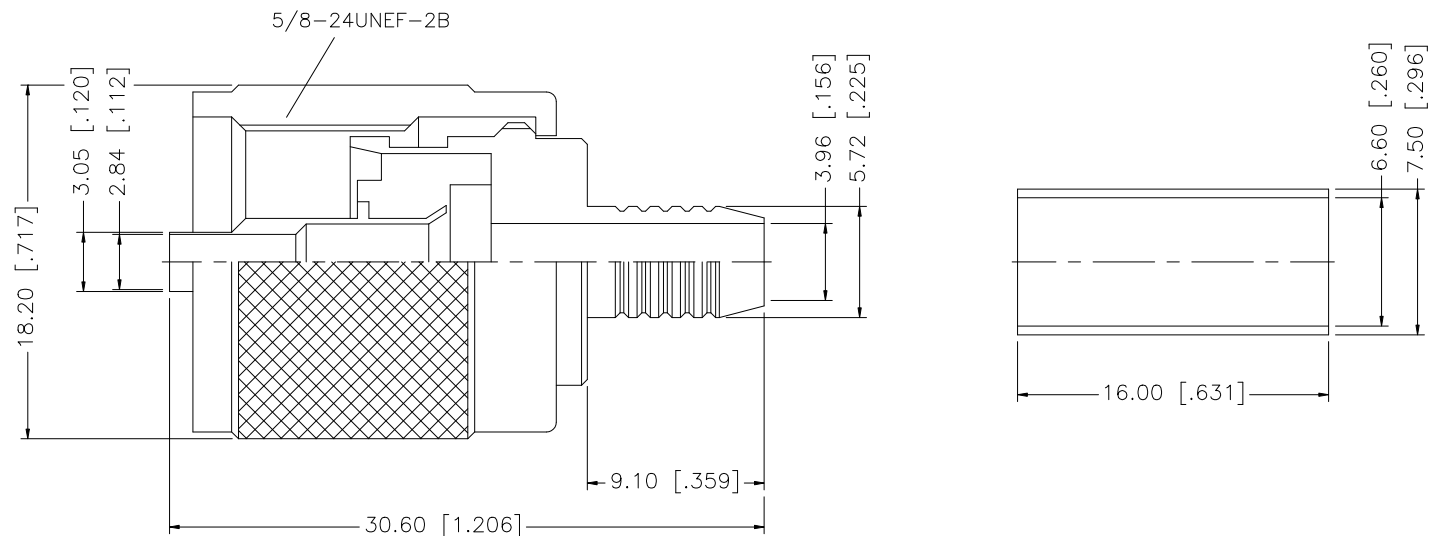

NOTES:

1. CRIMPED FERRULE HEX CRIMP SIZE .255" [6.54]

				UNLESS OTHERWISE SPECIFIED DIMENSIONS ARE IN MILLIMETERS. DIMENSIONS IN [] ARE IN INCHES AND FOR CUSTOMER REFERENCE ONLY.	APPROVALS	DATE	Amphenol Connex				
8				UNLESS OTHERWISE SPECIFIED TOLERANCES FOR MILLIMETERS ARE: 0.5 - 8mm ± 0.20mm 8 - 30mm ± 0.40mm 30 - 120mm ± 0.50mm	DRAWN	GRS				03/16/09	PART DESCRIPTION UHF CRIMP PLUG (FOR RG-59/U CABLE)
7					CHECKED			PART NO. 182101-10			
6				UNLESS OTHERWISE SPECIFIED TOLERANCES FOR INCHES ARE: .020 - .315 = ± 0.007" .315 - 1.180 = ± 0.015" 1.180 - 4.724 = ± 0.020"	ISSUED						DWG. NO. 182101-10.DWG
5					SHEET	1 OF 1		REV. B	SIZE A	SCALE NA	
4	FERRULE	COPPER	NICKEL	1	CAD FILE	C:/182/182101-10.DWG					
3	CONTACT PIN	BRASS	GOLD	1	DO NOT SCALE DRAWING						
2	INSULATOR	PHENOLIC	YELLOW	1							
1	BODY/SHELL	BRASS	NICKEL	1							
	DESCRIPTION	MATERIAL	FINISH	QTY							