

100336 Low Power 4-Stage Counter/Shift Register

General Description

The 100336 operates as either a modulo-16 up/down counter or as a 4-bit bidirectional shift register. Three Select (S_n) inputs determine the mode of operation, as shown in the Function Select table. Two Count Enable (\overline{CEP} , \overline{CET}) inputs are provided for ease of cascading in multistage counters. One Count Enable (\overline{CET}) input also doubles as a Serial Data (D_0) input for shift-up operation. For shift-down operation, D_3 is the Serial Data input. In counting operations the Terminal Count (\overline{TC}) output goes LOW when the counter reaches 15 in the count/up mode or 0 (zero) in the count/down mode. In the shift modes, the \overline{TC} output repeats the Q_3 output. The dual nature of this \overline{TC}/Q_3 output and the D_0/\overline{CET} input means that one interconnection from one stage to the next higher stage serves as the link for multistage counting or shift-up operation. The individual Preset (P_n) inputs are used

to enter data in parallel or to preset the counter in programmable counter applications. A HIGH signal on the Master Reset (\overline{MR}) input overrides all other inputs and asynchronously clears the flip-flops. In addition, a synchronous clear is provided, as well as a complement function which synchronously inverts the contents of the flip-flops. All inputs have 50 k Ω pull-down resistors.

Features

- 40% power reduction of the 100136
- 2000V ESD protection
- Pin/function compatible with 100136
- Voltage compensated operating range = -4.2V to -5.7V
- Standard Microcircuit Drawing (SMD) 5962-9230601

Logic Symbol

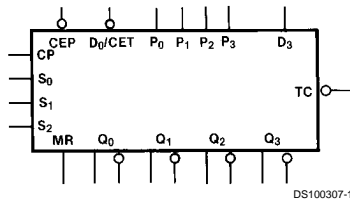

Pin Names	Description
CP	Clock Pulse Input
\overline{CEP}	Count Enable Parallel Input (Active LOW)
D_0/\overline{CET}	Serial Data Input/Count Enable Trickle Input (Active LOW)
S_0 - S_2	Select Inputs
\overline{MR}	Master Reset Input
P_0 - P_3	Preset Inputs
D_3	Serial Data Input
\overline{TC}	Terminal Count Output
Q_0 - Q_3	Data Outputs
$\overline{Q_0}$ - $\overline{Q_3}$	Complementary Data Outputs

Connection Diagrams

24-Pin DIP

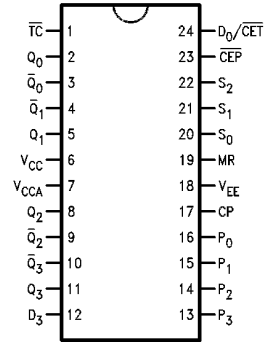

24-Pin Quad Cerpak

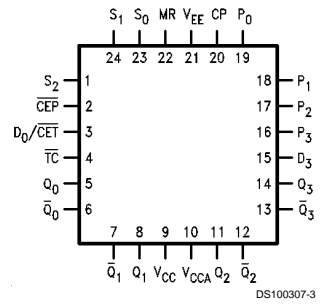

Logic Diagram

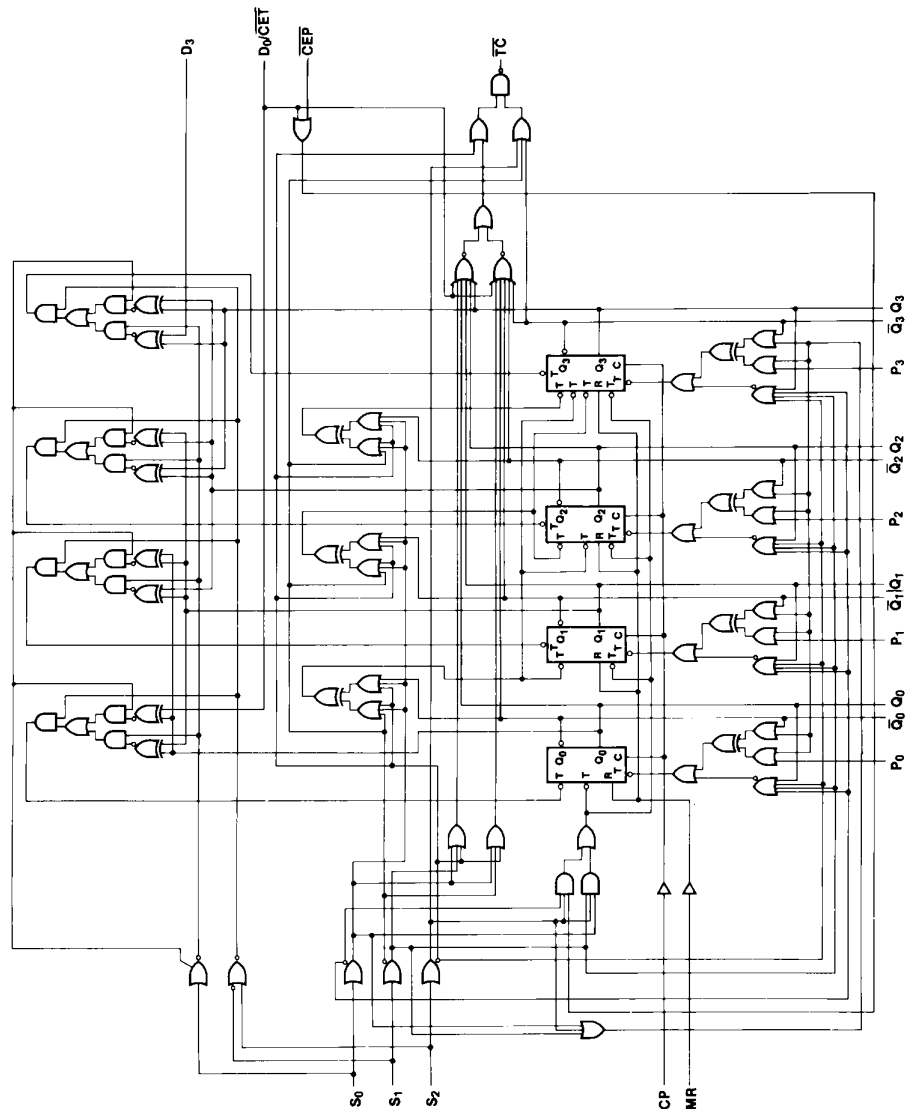

DS100307-5

Function Select Table

S ₂	S ₁	S ₀	Function
L	L	L	Parallel Load
L	L	H	Complement
L	H	L	Shift Left
L	H	H	Shift Right
H	L	L	Count Down
H	L	H	Clear
H	H	L	Count Up
H	H	H	Hold

Truth Table

Q₀ = LSB

Inputs								Outputs					TC	Mode
MR	S ₂	S ₁	S ₀	CEP	D ₀ /CET	D ₃	CP	Q ₃	Q ₂	Q ₁	Q ₀			
L	L	L	L	X	X	X	↗	P ₃	P ₂	P ₁	P ₀	L	Preset (Parallel Load)	
L	L	L	H	X	X	X	↗	\overline{Q}_3	\overline{Q}_2	\overline{Q}_1	\overline{Q}_0	L	Invert	
L	L	H	L	X	X	X	↗	D ₃	Q ₃	Q ₂	Q ₁	D ₃	Shift to LSB	
L	L	H	H	X	X	X	↗	Q ₂	Q ₁	Q ₀	D ₀	Q ₃ (Note 1)	Shift to MSB	
L	H	L	L	L	L	X	↗	(Q ₀₋₃) minus 1				1	Count Down	
L	H	L	L	H	L	X	X	Q ₃	Q ₂	Q ₁	Q ₀	1	Count Down with CEP not active	
L	H	L	L	X	H	X	X	Q ₃	Q ₂	Q ₁	Q ₀	H	Count Down with CET not active	
L	H	L	H	X	X	X	↗	L	L	L	L	H	Clear	
L	H	H	L	L	L	X	↗	(Q ₀₋₃) plus 1				2	Count Up	
L	H	H	L	H	L	X	X	Q ₃	Q ₂	Q ₁	Q ₀	2	Count Up with CEP not active	
L	H	H	L	X	H	X	X	Q ₃	Q ₂	Q ₁	Q ₀	H	Count Up with CET not active	
L	H	H	H	X	X	X	X	Q ₃	Q ₂	Q ₁	Q ₀	H	Hold	
H	L	L	L	X	X	X	X	L	L	L	L	L	Asynchronous Master Reset	
H	L	L	H	X	X	X	X	L	L	L	L	L		
H	L	H	L	X	X	X	X	L	L	L	L	L		
H	L	H	H	X	X	X	X	L	L	L	L	L		
H	H	L	L	X	L	X	X	L	L	L	L	L		
H	H	L	H	X	H	X	X	L	L	L	L	H		
H	H	L	H	X	X	X	X	L	L	L	L	H		
H	H	H	L	X	X	X	X	L	L	L	L	H		
H	H	H	H	X	X	X	X	L	L	L	L	H		

1 = L if Q₀-Q₃ = LLLL

H if Q₀-Q₃ ≠ LLLL

2 = L if Q₀-Q₃ = HHHH

H if Q₀-Q₃ ≠ HHHH

H = HIGH Voltage Level

L = LOW Voltage Level

X = Don't Care

↗ = LOW-to-HIGH Transition

Note 1: Before the clock, TC is Q₃

After the clock, TC is Q₂

Absolute Maximum Ratings (Note 2)

If Military/Aerospace specified devices are required, please contact the National Semiconductor Sales Office/Distributors for availability and specifications.

Storage Temperature (T_{STG})	-65°C to +150°C
Maximum Junction Temperature (T_J)	
Ceramic	+175°C
V_{EE} Pin Potential to Ground Pin	-7.0V to +0.5V
Input Voltage (DC)	V_{EE} to +0.5V
Output Current (DC Output HIGH)	-50 mA
ESD (Note 3)	≥2000V

Military Version DC Electrical Characteristics

$V_{EE} = -4.2V$ to $-5.7V$, $V_{CC} = V_{CCA} = GND$, $T_C = -55^\circ C$ to $+125^\circ C$

Recommended Operating Conditions

Case Temperature (T_C)	
Military	-55°C to +125°C
Supply Voltage (V_{EE})	-5.7V to -4.2V

Note 2: Absolute maximum ratings are those values beyond which the device may be damaged or have its useful life impaired. Functional operation under these conditions is not implied.

Note 3: ESD testing conforms to MIL-STD-883, Method 3015.

Symbol	Parameter	Min	Max	Units	T_C	Conditions	Notes
V_{OH}	Output HIGH Voltage	-1025	-870	mV	0°C to +125°C	$V_{IN} = V_{IH (Max)}$ or $V_{IL (Min)}$	Loading with 50Ω to -2.0V (Notes 4, 5, 6)
		-1085	-870	mV	-55°C		
V_{OL}	Output LOW Voltage	-1830	-1620	mV	0°C to +125°C		
		-1830	-1555	mV	-55°C		
V_{OHC}	Output HIGH Voltage	-1035		mV	0°C to +125°C	$V_{IN} = V_{IH (Min)}$ or $V_{IL (Max)}$	Loading with 50Ω to -2.0V (Notes 4, 5, 6)
		-1085		mV	-55°C		
V_{OLC}	Output LOW Voltage		-1610	mV	0°C to +125°C		
			-1555	mV	-55°C		
V_{IH}	Input HIGH Voltage	-1165	-870	mV	-55°C to +125°C	Guaranteed HIGH Signal for All Inputs	(Notes 4, 5, 6, 7)
V_{IL}	Input LOW Voltage	-1830	-1475	mV	-55°C to +125°C	Guaranteed LOW Signal for All Inputs	(Notes 4, 5, 6, 7)
I_{IL}	Input LOW Current	0.50		μA	-55°C to +125°C	$V_{EE} = -4.2V$ $V_{IN} = V_{IL (Min)}$	(Notes 4, 5, 6)
I_{IH}	Input HIGH Current		240	μA	0°C to +125°C	$V_{EE} = -5.7V$ $V_{IN} = V_{IH (Max)}$	(Notes 4, 5, 6)
			340	μA	-55°C		
I_{EE}	Power Supply Current	-185	-70	mA	-55°C to +125°C	Inputs Open $V_{EE} = -4.2V$ to $-4.8V$ $V_{EE} = -4.2V$ to $-5.7V$	(Notes 4, 5, 6)
		-195	-70	mA			

Note 4: F100K 300 Series cold temperature testing is performed by temperature soaking (to guarantee junction temperature equals -55°C), then testing immediately without allowing for the junction temperature to stabilize due to heat dissipation after power-up. This provides "cold start" specs which can be considered a worst case condition at cold temperatures.

Note 5: Screen tested 100% on each device at -55°C, +25°C, and +125°C, Subgroups 1, 2, 3, 7, and 8.

Note 6: Sample tested (Method 5005, Table I) on each manufactured lot at -55°C, +25°C, +125°C, Subgroups A1, 2, 3, 7, and 8.

Note 7: Guaranteed by applying specified input condition and testing V_{OH}/V_{OL} .

Military Version AC Characteristics

$$V_{EE} = -4.2V \text{ to } -5.7V, V_{CC} = V_{CCA} = GND$$

Symbol	Parameter	$T_C = -55^\circ\text{C}$		$T_C = +25^\circ\text{C}$		$T_C = +125^\circ$		Units	Conditions	Notes
		Min	Max	Min	Max	Min	Max			
f_{shift}	Shift Frequency	325		325		325		MHz	Figures 2, 3	(Note 11)
t_{PLH}	Propagation Delay	0.40	2.30	0.50	2.20	0.40	2.50	ns	Figures 1, 3	(Notes 8, 9, 10, 12)
t_{PHL}	CP to Q_n, \bar{Q}_n									
t_{PLH}	Propagation Delay	1.30	3.90	1.70	3.80	1.70	4.20	ns	Figures 1, 7, 8	
t_{PHL}	CP to \bar{TC} (Shift)									
t_{PLH}	Propagation Delay	1.20	4.60	1.50	4.60	1.60	5.20	ns	Figures 1, 9	(Notes 8, 9, 10, 12)
t_{PHL}	CP to \bar{TC} (Count)									
t_{PLH}	Propagation Delay	0.60	2.90	0.80	2.80	0.90	3.20	ns	Figures 1, 4	(Notes 8, 9, 10, 12)
t_{PHL}	MR to Q_n, \bar{Q}_n									
t_{PLH}	Propagation Delay	2.30	5.20	2.70	5.20	2.90	5.90	ns	Figures 1, 12	
t_{PHL}	MR to \bar{TC} (Count)									
t_{PHL}	Propagation Delay	2.10	4.30	2.20	4.10	2.40	4.70	ns	Figures 1, 10, 11	(Notes 8, 9, 10, 12)
t_{PHL}	MR to \bar{TC} (Shift)									
t_{PLH}	Propagation Delay	0.70	3.20	1.00	3.20	1.30	4.10	ns	Figures 1, 5	(Notes 8, 9, 10, 12)
t_{PHL}	D_0/\bar{CET} to \bar{TC}									
t_{PLH}	Propagation Delay	1.30	4.10	1.50	4.20	1.70	4.90	ns		
t_{PHL}	S_n to \bar{TC}									
t_{TLH}	Transition Time	0.20	1.90	0.20	1.80	0.20	2.00	ns	Figures 1, 3	(Note 11)
t_{THL}	20% to 80%, 80% to 20%									
t_s	Setup Time									
	D_3	1.40		1.40		1.40		ns	Figure 6	(Note 11)
	P_n	1.70		1.70		1.70				
	D_0/\bar{CET}	1.80		1.80		1.80				
	\bar{CEP}	1.80		1.80		1.80				
	S_n	3.30		3.30		3.30				
	MR (Release Time)	2.60		2.60		2.60				
t_h	Hold Time							ns	Figure 6	(Note 11)
	D_3	0.90		0.90		0.90				
	P_n	1.00		1.00		1.00				
	D_0/\bar{CET}	0.70		0.70		0.70				
	\bar{CEP}	0.60		0.60		0.60				
	S_n	0.00		0.00		0.00				
$t_{\text{pw(H)}}$	Pulse Width	1.60		1.60		1.60		ns	Figures 3, 4	(Note 11)
	HIGH: CP									
	MR	2.00		2.00		2.00				

Note 8: F100K 300 Series cold temperature testing is performed by temperature soaking (to guarantee junction temperature equals -55°C), then testing immediately after power-up. This provides "cold start" specs which can be considered a worst case condition at cold temperatures.

Note 9: Screen tested 100% on each device at $+25^\circ\text{C}$ temperature only, Subgroups A9.

Note 10: Sample tested (Method 5005, Table I) on each manufactured lot at $+25^\circ\text{C}$, Subgroups A9, and at $+125^\circ\text{C}$ and -55°C temperatures, Subgroups A10 and A11.

Note 11: Not tested at $+25^\circ\text{C}$, $+125^\circ\text{C}$, and -55°C temperature (design characterization data).

Note 12: The propagation delay specified is for single output switching. Delays may vary up to 250 ps with multiple outputs switching.

Test Circuitry

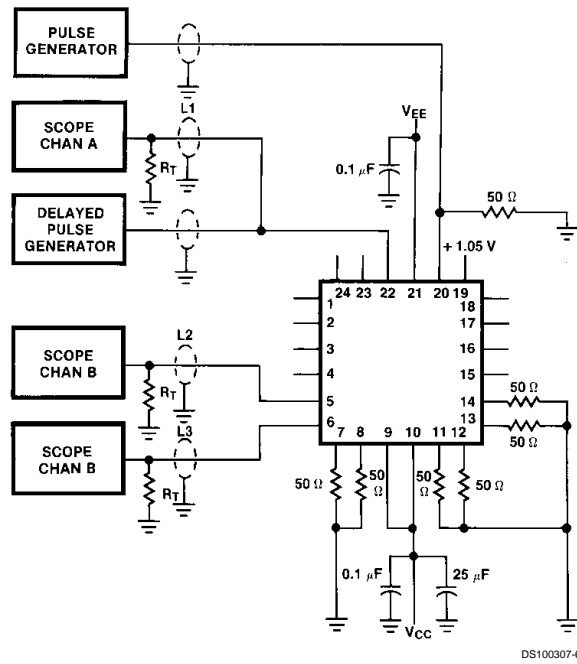

Notes:

$V_{CC}, V_{CCA} = +2V, V_{EE} = -2.5V$
 $L1, L2$ and $L3$ = equal length 50Ω impedance lines
 $R_T = 50\Omega$ terminator internal to scope
 Decoupling $0.1 \mu F$ from GND to V_{CC} and V_{EE}
 All unused outputs are loaded with 50Ω to GND
 C_L = Fixture and stray capacitance ≤ 3 pF
 Pin numbers shown are for flatpak;
 for DIP see logic symbol

FIGURE 1. AC Test Circuit

Test Circuitry (Continued)

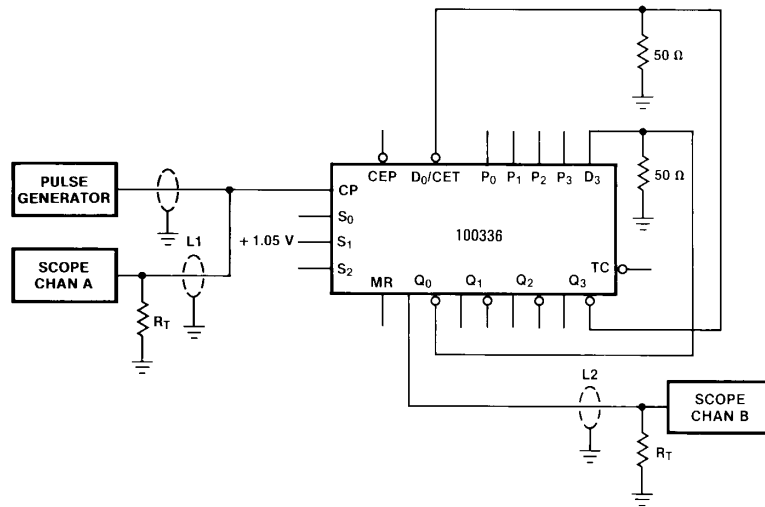

DS100307-7

Notes:

For shift right mode, +1.05V is applied at S₀.
The feedback path from output to input should be as short as possible.

FIGURE 2. Shift Frequency Test Circuit (Shift Left)

Switching Waveforms

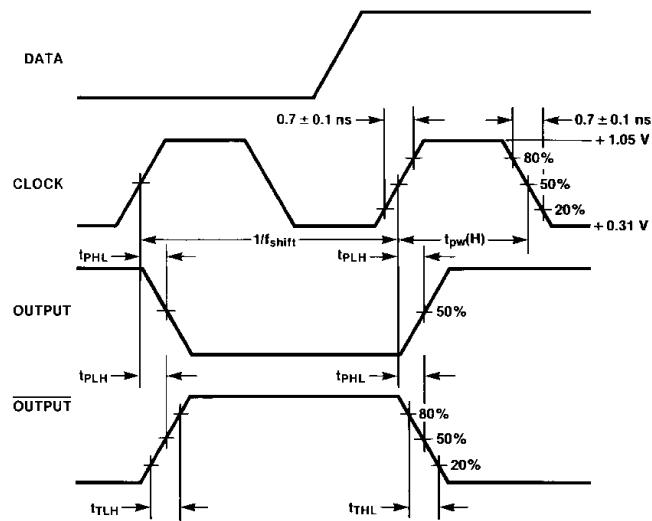

DS100307-8

FIGURE 3. Propagation Delay (Clock) and Transition Times

Switching Waveforms (Continued)

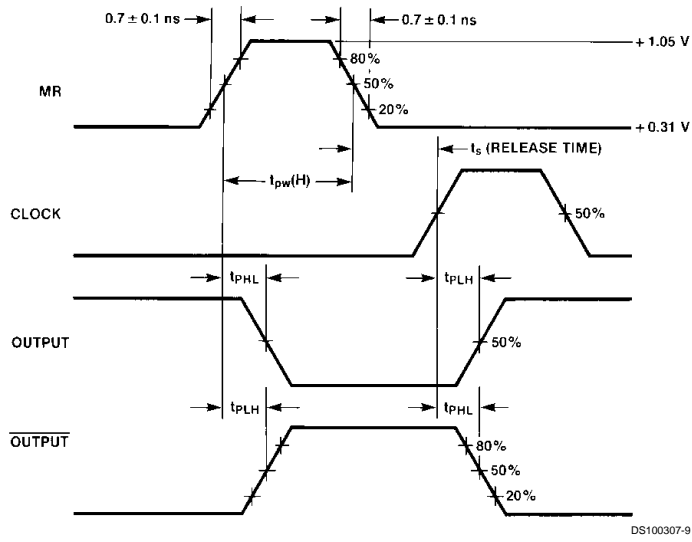

FIGURE 4. Propagation Delay (Reset)

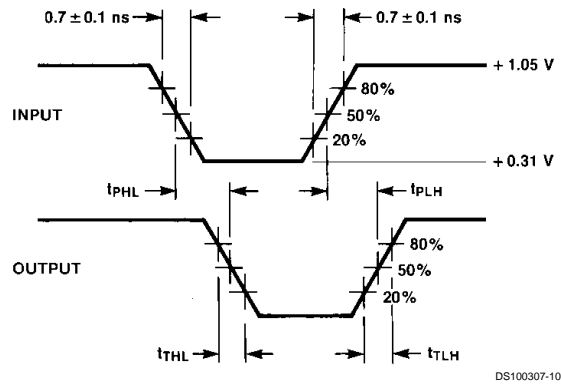
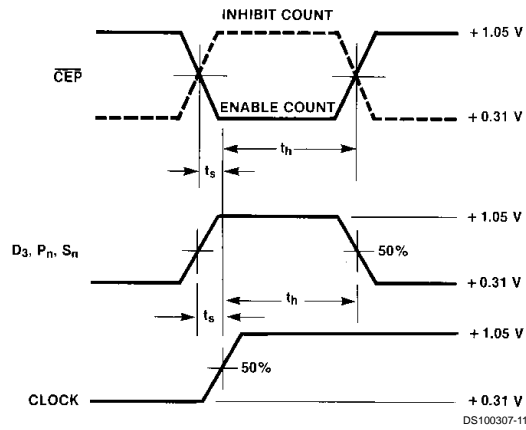

FIGURE 5. Propagation Delay (Serial Data, Selects)

Switching Waveforms (Continued)



Notes:

t_s is the minimum time before the transition of the clock that information must be present at the data input.
 t_h is the minimum time after the transition of the clock that information must remain unchanged at the data input.

FIGURE 6. Setup and Hold Time

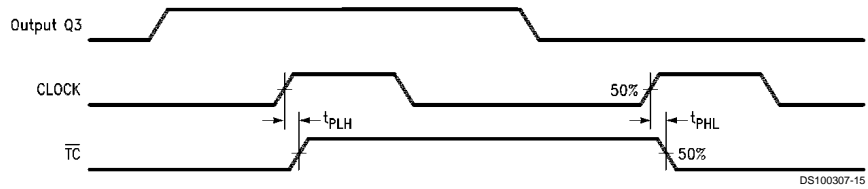

Note: Shift Right Mode; S₀ = H, S₁ = H, S₂ = L.

FIGURE 7. Propagation Delay, Clock to Terminal Count (Shift Right Mode)

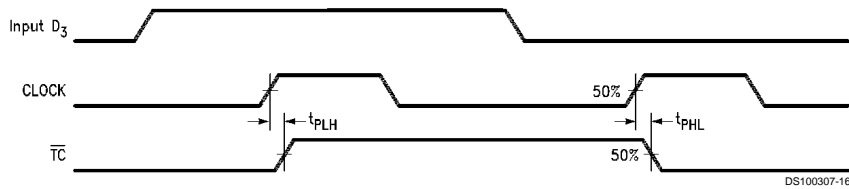

Note: Shift Left Mode; S₀ = L, S₁ = H, S₂ = L.

FIGURE 8. Propagation Delay, Clock to Terminal Count (Shift Left Mode)

Switching Waveforms (Continued)

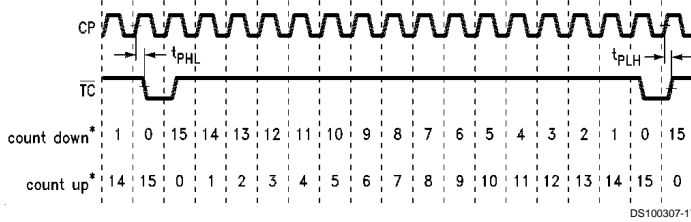

Note:

*Decimal representation of binary outputs.

Count Up: $S_0 = L, S_1 = H, S_2 = H$; Count Down: $S_0 = L, S_1 = L, S_2 = H$.

Measurement taken at 50% point of waveform.

FIGURE 9. Propagation Delay, Clock to Terminal Count (Count Up and Count Down Modes)

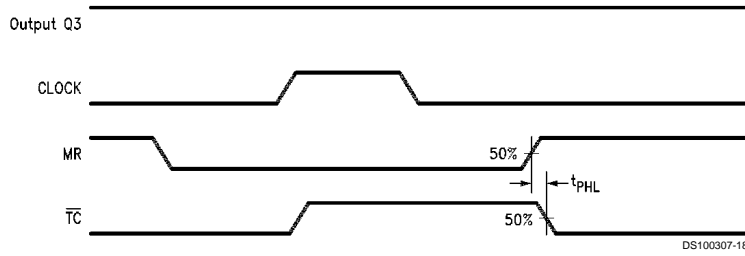

Note: Shift Right Mode; $S_0 = H, S_1 = H, S_2 = L$.

FIGURE 10. Propagation Delay, Master Reset to Terminal Count (Shift Right Mode)

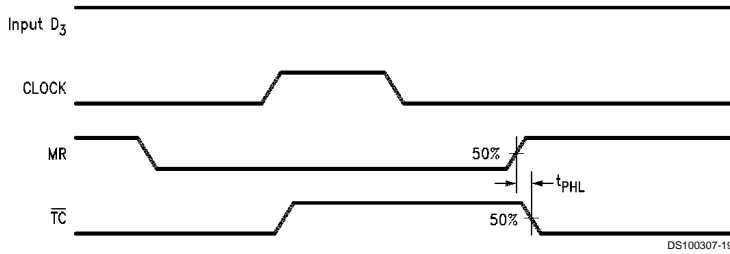

Note: Shift Left Mode; $S_0 = L, S_1 = H, S_2 = L$.

FIGURE 11. Propagation Delay, Master Reset to Terminal Count (Shift Left Mode)

Switching Waveforms (Continued)

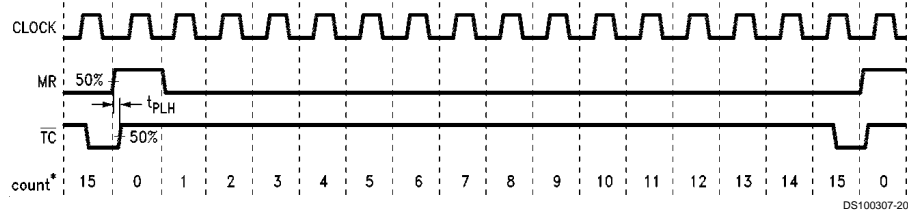

Note:

*Decimal representation of binary outputs. Count Up Mode: $S_0 = L, S_1 = H, S_2 = H$.

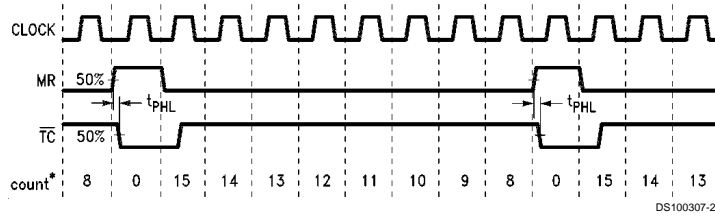

Note:

*Decimal representation of binary outputs. Count Down Mode: $S_0 = L, S_1 = L, S_2 = H$.

FIGURE 12. Propagation Delay, Master Reset to Terminal Count (Count Up and Count Down Modes)

Applications

3-Stage Divider, Preset Count Down Mode

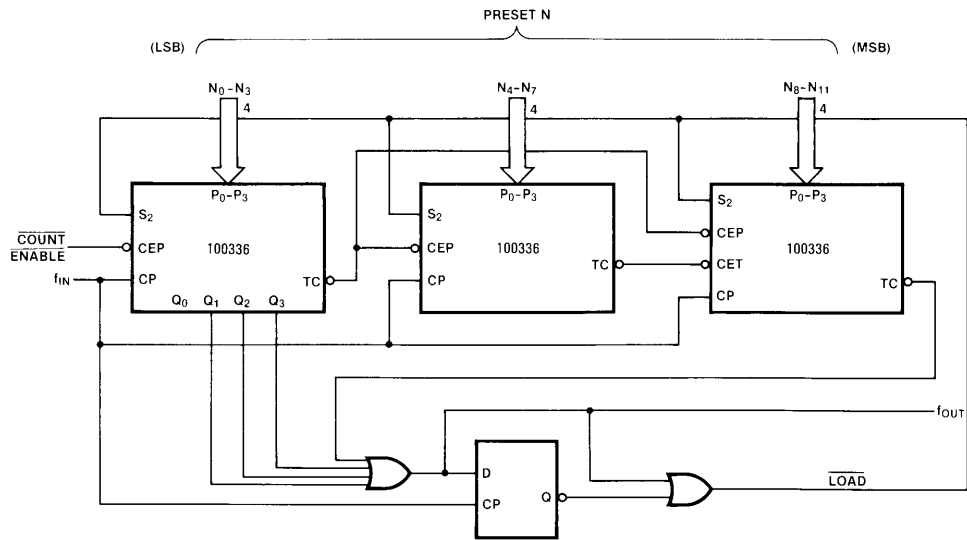

Note: If $S_0 = S_1 = S_2 = LOW$, then $T_C = LOW$

Applications (Continued)

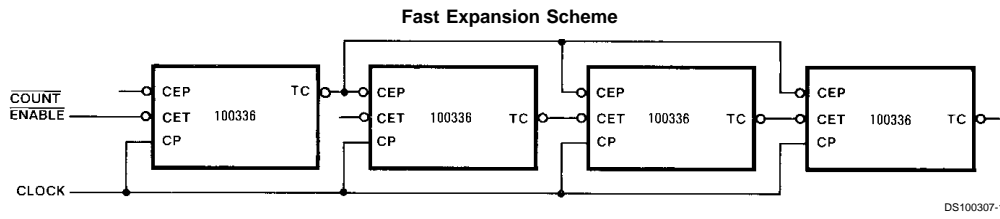
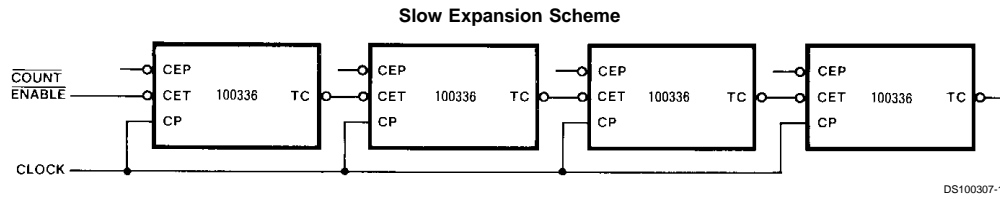



Physical Dimensions inches (millimeters) unless otherwise noted

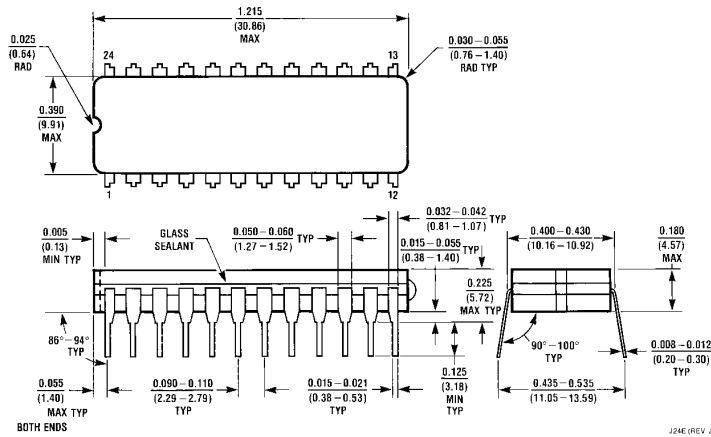

24-Lead Ceramic Dual-In-Line Package (0.400" Wide) (D)
NS Package Number J24E

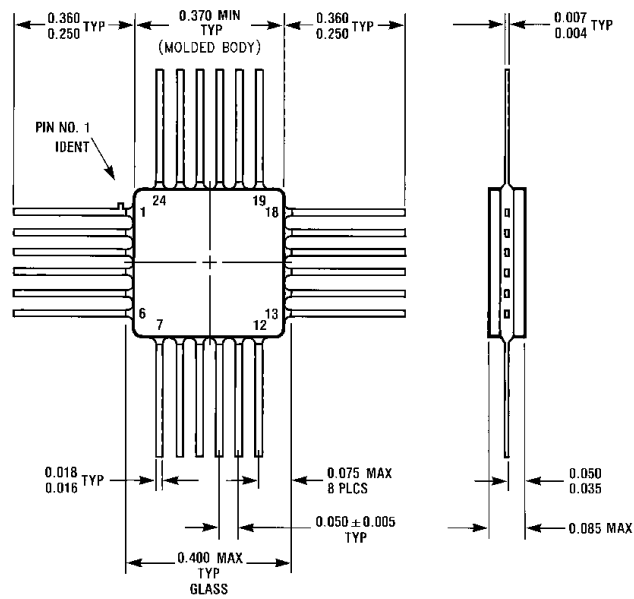

24-Lead Quad Cerpak (F)
NS Package Number W24B

LIFE SUPPORT POLICY

NATIONAL'S PRODUCTS ARE NOT AUTHORIZED FOR USE AS CRITICAL COMPONENTS IN LIFE SUPPORT DEVICES OR SYSTEMS WITHOUT THE EXPRESS WRITTEN APPROVAL OF THE PRESIDENT OF NATIONAL SEMICONDUCTOR CORPORATION. As used herein:

1. Life support devices or systems are devices or systems which, (a) are intended for surgical implant into the body, or (b) support or sustain life, and whose failure to perform when properly used in accordance with instructions for use provided in the labeling, can be reasonably expected to result in a significant injury to the user.
2. A critical component in any component of a life support device or system whose failure to perform can be reasonably expected to cause the failure of the life support device or system, or to affect its safety or effectiveness.



National Semiconductor Corporation
Americas
Tel: 1-800-272-9959
Fax: 1-800-737-7018
Email: support@nsc.com

www.national.com

National Semiconductor Europe
Fax: +49 (0) 1 80-530 85 86
Email: europe.support@nsc.com
Deutsch Tel: +49 (0) 1 80-530 85 85
English Tel: +49 (0) 1 80-532 78 32
Français Tel: +49 (0) 1 80-532 93 58
Italiano Tel: +49 (0) 1 80-534 16 80

National Semiconductor Asia Pacific Customer Response Group
Tel: 65-2544466
Fax: 65-2504466
Email: sea.support@nsc.com

National Semiconductor Japan Ltd.
Tel: 81-3-5620-6175
Fax: 81-3-5620-6179