

NOTES:

1. MATERIALS OF FINISHES:

- FERRULE - BRASS, GOLD PLATING
- DISC INSULATOR - PTFE, NATURAL
- GASKET - SILICONE RUBBER, RED
- RETAINER RING - SUS 304, NATURAL
- BODY - BRASS, GOLD PLATING
- CONTACT PIN - BRASS, GOLD PLATING
- INSULATOR - PTFE, NATURAL
- SHELL - BRASS, GOLD PLATING

2. ELECTRICAL:

- A. IMPEDANCE: 50 OHM
- B. FREQUENCY RANGE: 0-6 GHZ
- C. VSWR (RETURN LOSS): 1.2 (-20.828 dB) MAX.
- D. INSERTION LOSS: <0.3 dB TO <0.7 dB @ 0-3 GHZ
- E. D.W.V: 1000 VRMS, MIN.

3. MECHANICAL:

- A. DURABILITY: 500 CYCLES MIN.
- B. TEMPERATURE RANGE: -65°C TO +165°C

4. CRIMPED FERRULE HEX CRIMP SIZE .255"

5. CONTACT PIN TO SOLDER

THIRD ANGLE PROJ.

REVISIONS

REV	DESCRIPTION	DATE	ECO	APPR
A	RELEASE TO MFG.	30-Mar-15	2888	BCG

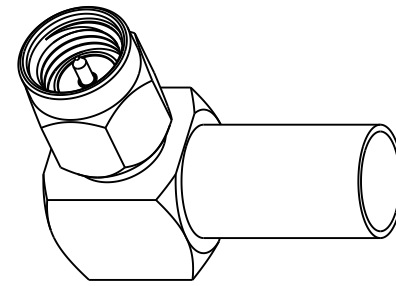

SCALE 2.000

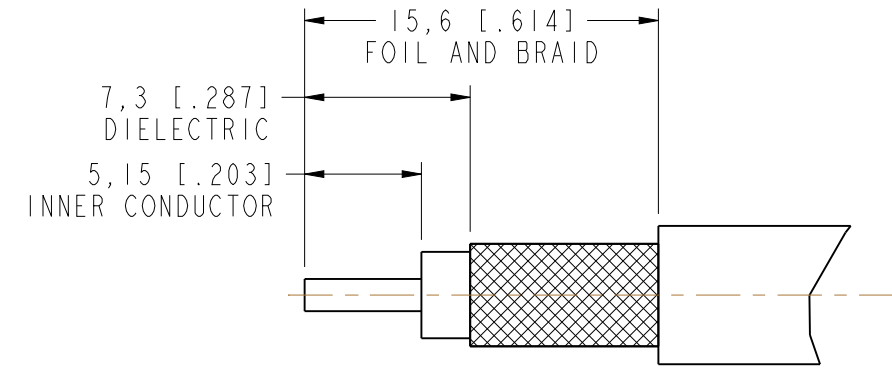

RECOMMENDED
CABLE STRIPPING DIM'S
SCALE 3.000

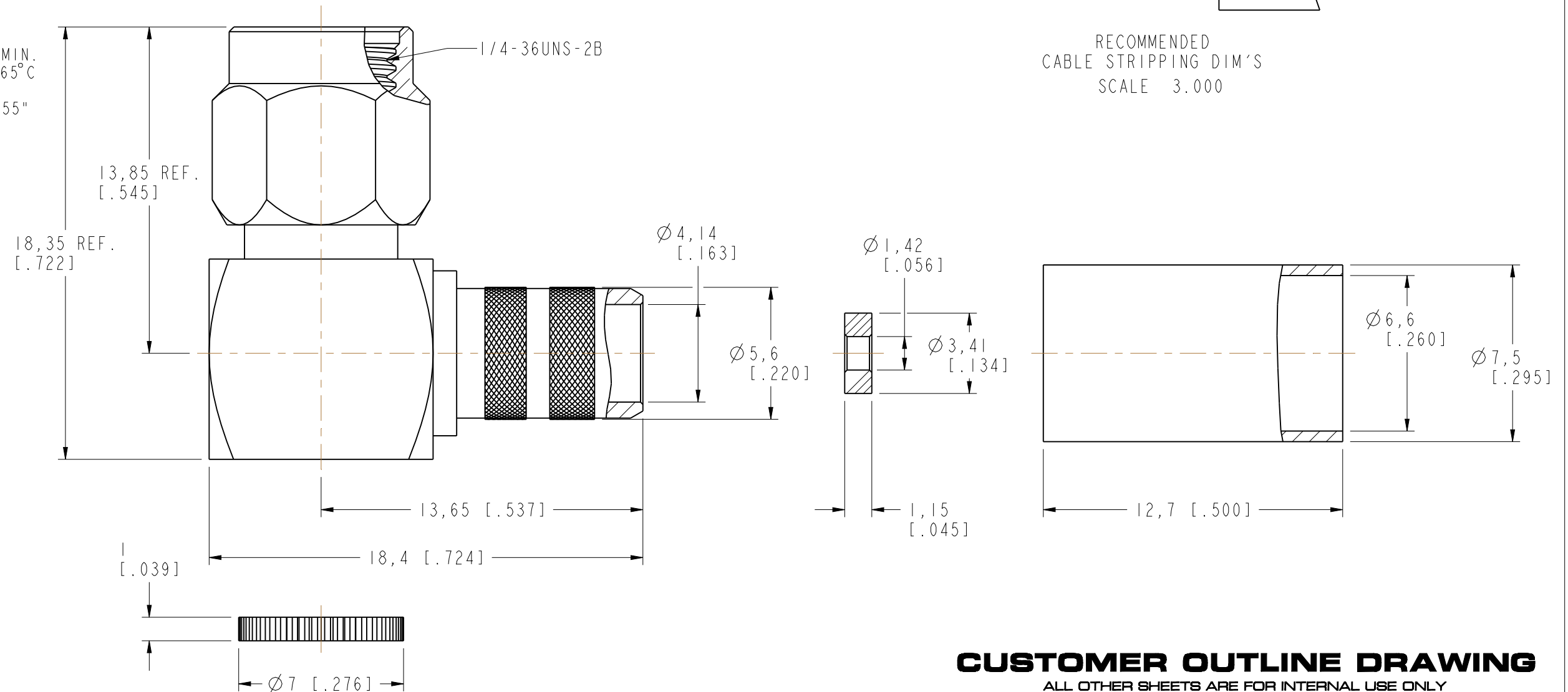

CUSTOMER OUTLINE DRAWING

ALL OTHER SHEETS ARE FOR INTERNAL USE ONLY

UNLESS OTHERWISE SPECIFIED, DIMENSIONS ARE IN METRIC AND TOLERANCES ARE:
 <0.5mm ±0.05mm 0.5 - 6mm ±0.1mm 6 - 30mm ±0.2mm 30 - 120mm ±0.3mm ANGLES ±1°

NOTICE - These drawings, specifications, or other data (1) are, and remain the property of Amphenol corp. (2) must be returned upon request; and (3) are confidential and not to be disclosed to any person other than those to whom they are given by Amphenol Corp. the furnishing of these drawings, specifications, or other data by Amphenol Corp., or to any other person to anyone for any purpose is not to be regarded by implication or otherwise in any manner licensing, granting rights to permitting such holder or any other person to manufacture, use or sell any product, process or design, patented or otherwise, that may in any way be related to or disclosed by said drawings, specifications, or other data.

MATERIAL	DRAWN M.ZHANG	DATE 30-Mar-15	TITLE SMA R/A CRIMP PLUG (FOR RG-8/X, LMR-240)		Amphenol Connex
REFERENCE EAR# 6467 SMA112A1-008-3GT5GP-50 CONFIGURATION LEVEL: In Work	ENGINEER S.DUAN	DATE 30-Mar-15	DRAWING NO.		
FINISH	APPROVED B.C. GLEISSNER	DATE 30-Mar-15	SCALE: 5.0:1.0	SHEET 3 OF 3	ITEM NO.
	CAD FILE		DWG SIZE B	REV A	PART NO. 132452