

TMS570LS3137-EP 16- and 32-Bit RISC Flash Microcontroller

1 Device Overview

1.1 Features

- High-Performance Microcontroller for Safety-Critical Applications
 - Dual CPUs Running in Lockstep
 - ECC on Flash and RAM interfaces
 - Built-In Self-Test for CPU and On-chip RAMs
 - Error Signaling Module with Error Pin
 - Voltage and Clock Monitoring
- ARM® Cortex™ – R4F 32-Bit RISC CPU
 - Efficient 1.66 DMIPS/MHz with 8-Stage Pipeline
 - FPU with Single- and Double-Precision
 - 12-Region Memory Protection Unit
 - Open Architecture with Third-Party Support
- Operating Conditions
 - Up to 180-MHz System Clock
 - Core Supply Voltage (VCC): 1.2 V Nominal
 - I/O Supply Voltage (VCCIO): 3.3 V Nominal
 - ADC Supply Voltage (V_{CCAD}): 3.0 to 5.25 V
 - IP Modules GBD for -40°C to 125°C Only includes Flash, MibADC timings, nPORRST, N2HET, and FlexRay
- Integrated Memory
 - 3MB of Program Flash With ECC
 - 256KB of RAM With ECC
 - 64KB of Flash With ECC for Emulated EEPROM
- 16-Bit External Memory Interface
- Common Platform Architecture
 - Consistent Memory Map Across Family
 - Real-Time Interrupt Timer (RTI) OS Timer
 - 96-Channel Vectored Interrupt Module (VIM)
 - 2-Channel Cyclic Redundancy Checker (CRC)
- Direct Memory Access (DMA) Controller
 - 16 Channels and 32 Control Packets
 - Parity Protection for Control Packet RAM
 - DMA Accesses Protected by Dedicated MPU
- Frequency-Modulated Phase-Locked-Loop (FMPLL) with Built-In Slip Detector
- Separate Nonmodulating PLL
- IEEE 1149.1 JTAG, Boundary Scan and ARM CoreSight™ Components
- JTAG Security Module
- Trace and Calibration Capabilities
 - Embedded Trace Macrocell (ETM-R4)
 - Data Modification Module (DMM)
 - RAM Trace Port (RTP)
 - Parameter Overlay Module (POM)
- Multiple Communication Interfaces
 - 10/100 Mbps Ethernet MAC (EMAC)
 - IEEE 802.3 Compliant (3.3-V I/O only)
 - Supports MII, RMII and MDIO
 - FlexRay Controller with Two Channels
 - 8 KB message RAM with Parity Protection
 - Dedicated Transfer Unit (FTU)
 - Three CAN Controllers (DCANs)
 - 64 Mailboxes, Each with Parity Protection
 - Compliant to CAN Protocol Version 2.0B
 - Local Interconnect Network (LIN) Interface Controller
 - Compliant to LIN Protocol Version 2.1
 - Can be Configured as a Second SCI
 - Standard Serial Communication Interface (SCI)
 - Inter-Integrated Circuit (I²C)
 - Three Multibuffered Serial Peripheral Interfaces (MibSPIs)
 - 128 Words with Parity Protection Each
 - Two Standard Serial Peripheral Interfaces (SPIs)
- Two High-End Timer Modules (N2HETs)
 - N2HET1: 32 Programmable Channels
 - N2HET2: 18 Programmable Channels
 - 160-Word Instruction RAM with Parity Protection Each
 - Each N2HET Includes Hardware Angle Generator
 - Dedicated Transfer Unit with MPU for Each N2HET (HTU)
- Two 10- or 12-bit Multibuffered ADC Modules
 - ADC1: 24 Channels
 - ADC2: 16 Channels Shared with ADC1
 - 64 Result Buffers with Parity Protection Each
- Sixteen General-Purpose Input/Output Pins (GPIO) Capable of Generating Interrupts
- Package
 - 337-Ball Grid Array (SnPb) (GWT)



1.2 Applications

- Braking Systems (Antilock Brake Systems and Electronic Stability Control)
- Electric Power Steering
- HEV and EV Inverter Systems
- Battery Management Systems
- Active Driver Assistance Systems
- Aerospace and Avionics
- Railway Communications
- Off-road Vehicles
- Supports Defense, Aerospace, and Medical Applications
 - Controlled Baseline
 - One Assembly and Test Site
 - One Fabrication Site
 - Available in –55°C to 125°C Temperature Range
 - Extended Product Life Cycle
 - Extended Product-Change Notification
 - Product Traceability

1.3 Description

The TMS570LS3137-EP device is a high-performance microcontroller family for safety systems. The safety architecture includes the following:

- Dual CPUs in lockstep
- CPU and memory built-in self-test (BIST) logic
- ECC on both the flash and the data SRAM
- Parity on peripheral memories
- Loopback capability on peripheral I/Os

The TMS570LS3137-EP device integrates the ARM Cortex-R4F Floating-Point CPU which offers an efficient 1.66 DMIPS/MHz, and has configurations which can run up to 180 MHz, providing up to 298 DMIPS. The device supports the word-invariant big-endian [BE32] format.

The TMS570LS3137-EP device has 3MB of integrated flash and 256KB of data RAM with single-bit error correction and double-bit error detection. The flash memory on this device is a nonvolatile, electrically erasable and programmable memory implemented with a 64-bit-wide data bus interface. The flash operates on a 3.3-V supply input (same level as I/O supply) for all read, program and erase operations. When in pipeline mode, the flash operates with a system clock frequency of up to 180 MHz. The SRAM supports single-cycle read and write accesses in byte, halfword, word and double-word modes.

The TMS570LS3137-EP device features peripherals for real-time control-based applications, including two Next Generation High-End Timer (N2HET) timing coprocessors and two 12-bit analog-to-digital converters (ADCs) supporting up to 24 inputs.

The N2HET is an advanced intelligent timer that provides sophisticated timing functions for real-time applications. The timer is software-controlled, using a reduced instruction set, with a specialized timer micromachine and an attached I/O port. The N2HET can be used for pulse-width-modulated outputs, capture or compare inputs, or GPIO. The N2HET is especially well suited for applications requiring multiple sensor information and drive actuators with complex and accurate time pulses. A High-End Timer Transfer Unit (HTU) can perform DMA-type transactions to transfer N2HET data to or from main memory. A Memory Protection Unit (MPU) is built into the HTU.

The device has two 12-bit-resolution MibADCs with 24 channels and 64 words of parity-protected buffer RAM each. The MibADC channels can be converted individually or can be grouped by software for sequential conversion sequences. Sixteen channels are shared between the two MibADCs. There are three separate groupings. Each sequence can be converted once when triggered or configured for continuous conversion mode.

The device has multiple communication interfaces: three MibSPIs, one LIN, one SCI, three DCANs, one I²C. The SPIs provide a convenient method of serial high-speed communication between similar shift-register type devices. The LIN supports the Local Interconnect standard 2.0 and can be used as a UART in full-duplex mode using the standard Non-Return-to-Zero (NRZ) format.

The DCAN supports the CAN 2.0 (A and B) protocol standard and uses a serial, multimaster communication protocol that efficiently supports distributed real-time control with robust communication rates of up to 1 Mbps. The DCAN is ideal for systems operating in noisy and harsh environments (for example, automotive vehicle networking and industrial fieldbus) that require reliable serial communication or multiplexed wiring.

The I2C module is a multimaster communication module providing an interface between the microcontroller and an I²C-compatible device via the I²C serial bus. The I²C supports speeds of 100 and 400 Kbps.

The frequency-modulated phase-locked loop (FMPLL) clock module is used to multiply the external frequency reference to a higher frequency for internal use. There are two FMPLL modules on this device. These modules, when enabled, provide two of the seven possible clock source inputs to the global clock module (GCM). The GCM manages the mapping between the available clock sources and the device clock domains.

The device also has an external clock prescaler (ECP) module that when enabled, outputs a continuous external clock on the ECLK pin/ball. The ECLK frequency is a user-programmable ratio of the peripheral interface clock (VCLK) frequency. This low-frequency output can be monitored externally as an indicator of the device operating frequency.

The DMA controller has 16 channels, 32 control packets and parity protection on its memory. An MPU is built into the DMA to limit the DMA to prescribed areas of memory and to protect the rest of the memory system from any malfunction of the DMA.

The Error Signaling Module (ESM) monitors all device errors and determines whether an interrupt is generated or the external $\overline{\text{ERROR}}$ pin is toggled when a fault is detected. The $\overline{\text{ERROR}}$ pin can be monitored externally as an indicator of a fault condition in the microcontroller.

The External Memory Interface (EMIF) provides off-chip expansion capability with the ability to interface to synchronous DRAM (SDRAM) devices, asynchronous memories, peripherals or FPGA devices.

Several interfaces are implemented to enhance the debugging capabilities of application code. In addition to the built in ARM Cortex-R4F CoreSight debug features an External Trace Macrocell (ETM) provides instruction and data trace of program execution. For instrumentation purposes, a RAM Trace Port (RTP) module is implemented to support high-speed tracing of RAM and peripheral accesses by the CPU or any other master. A Data Modification Module (DMM) gives the ability to write external data into the device memory. Both the RTP and DMM have no or only minimum impact on the program execution time of the application code. A Parameter Overlay Module (POM) can reroute flash accesses to internal memory or to the EMIF. This rerouting allows parameters and tables to be dynamically calibrated against production code without rebuilding the code to explicitly access RAM or halting the processor to reprogram the data flash.

With integrated safety features and a wide choice of communication and control peripherals, the device is an ideal solution for high-performance real-time control applications with safety-critical requirements.

Table 1-1. Device Information⁽¹⁾

ORDER NUMBER	PACKAGE	T _A
TMS5703137CGWTQEP	NFBGA (337)	–40°C to 125°C
TMS5703137CGWTMEP		–55°C to 125°C

(1) For more information, see [Section 9, Mechanical Packaging and Orderable Information](#).

1.4 Functional Block Diagram

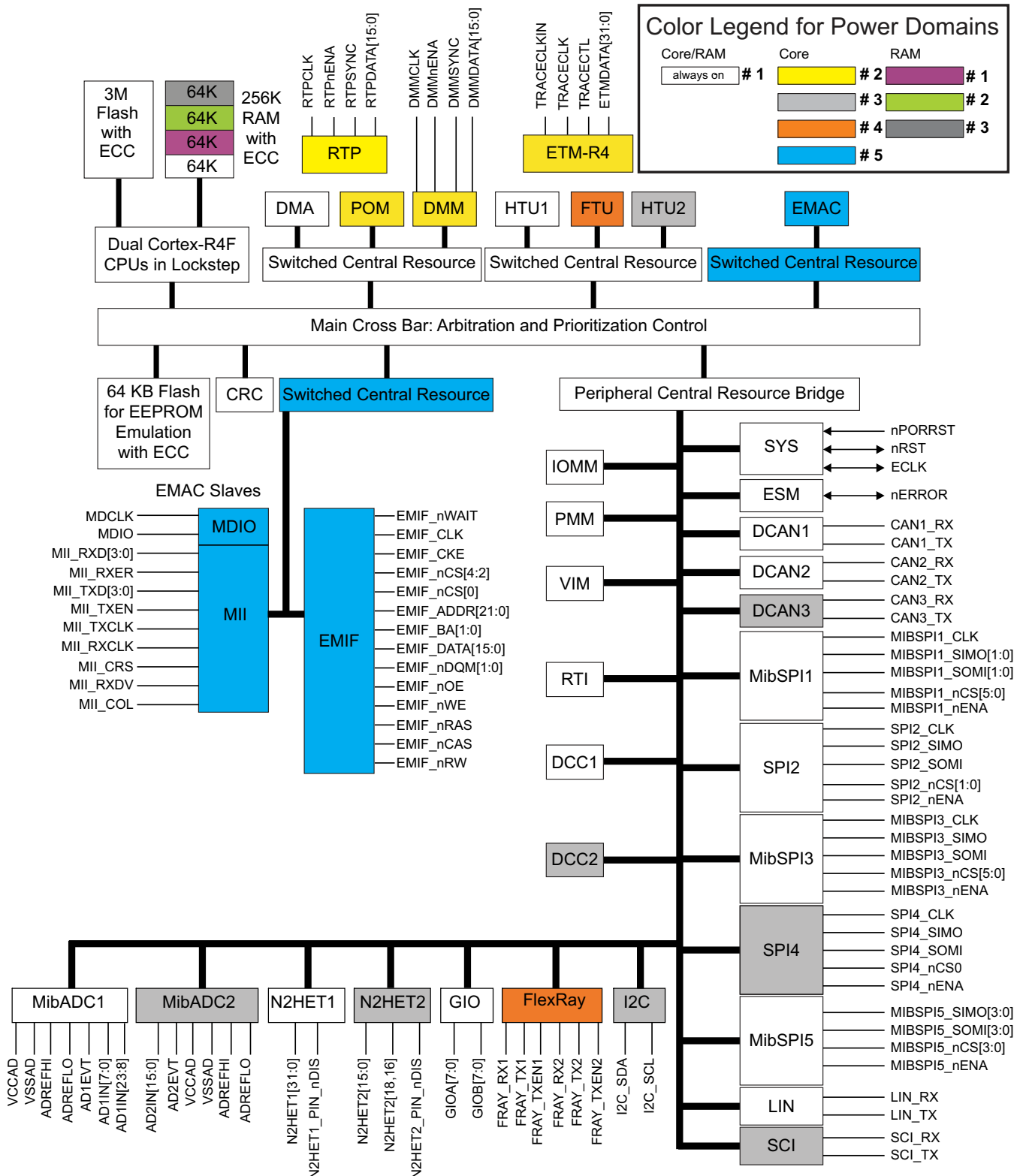

Figure 1-1. Functional Block Diagram

Table of Contents

1	Device Overview	1	6.11	Tightly-Coupled RAM Interface Module	67
	1.1 Features	1	6.12	Parity Protection for Peripheral RAMs	67
	1.2 Applications	2	6.13	On-Chip SRAM Initialization and Testing	69
	1.3 Description	2	6.14	External Memory Interface (EMIF)	71
	1.4 Functional Block Diagram	4	6.15	Vectored Interrupt Manager	78
2	Revision History	6	6.16	DMA Controller	81
3	Device Comparison Table	7	6.17	Real Time Interrupt Module	83
	3.1 Device Comparison	7	6.18	Error Signaling Module	85
4	Pin Configuration and Functions	8	6.19	Reset / Abort / Error Sources	89
	4.1 Pin Diagrams	8	6.20	Digital Windowed Watchdog	91
5	Specifications	29	6.21	Debug Subsystem	92
	5.1 Absolute Maximum Ratings	29	7	Peripheral Information	103
	5.2 ESD Ratings	29	7.1	Peripheral Legend	103
	5.3 Power-On Hours (POH)	29	7.2	Multi-Buffered 12bit Analog-to-Digital Converter ..	103
	5.4 Recommended Operating Conditions	29	7.3	General-Purpose Input/Output	114
	5.5 Power Consumption	31	7.4	Enhanced High-End Timer (N2HET)	115
	5.6 Thermal Data	31	7.5	FlexRay Interface	120
	5.7 Switching Characteristics	32	7.6	Controller Area Network (DCAN)	122
	5.8 Wait States Required	32	7.7	Local Interconnect Network Interface (LIN)	123
	5.9 I/O Electrical Characteristics	33	7.8	Serial Communication Interface (SCI)	124
	5.10 Output Buffer Drive Strengths	33	7.9	Inter-Integrated Circuit (I2C)	125
	5.11 Input Timings	34	7.10	Multi-Buffered / Standard Serial Peripheral Interface	128
	5.12 Output Timings	35	7.11	Ethernet Media Access Controller	141
	5.13 Low-EMI Output Buffers	37	8	Device and Documentation Support	145
6	System Information and Electrical Specifications	38	8.1	Device and Development-Support Tool Nomenclature	145
	6.1 Device Power Domains	38	8.2	Documentation Support	147
	6.2 Voltage Monitor Characteristics	39	8.3	Trademarks	147
	6.3 Power Sequencing and Power On Reset	40	8.4	Electrostatic Discharge Caution	147
	6.4 Warm Reset (nRST)	42	8.5	Glossary	147
	6.5 ARM® Cortex™-R4F CPU Information	43	8.6	Device Identification	148
	6.6 Clocks	46	8.7	Module Certifications	150
	6.7 Clock Monitoring	54	9	Mechanical, Packaging, and Orderable Information	153
	6.8 Glitch Filters	56	9.1	Packaging Information	153
	6.9 Device Memory Map	57			
	6.10 Flash Memory	64			

2 Revision History

NOTE: Page numbers for previous revisions may differ from page numbers in the current version.

Changes from Revision C (January 2015) to Revision D Page

- Corrected temperature range in [Table 1-1](#) [3](#)
-

Changes from Revision B (October 2013) to Revision C Page

- Updated formatting to new standards [1](#)
 - Increased available temperature range [2](#)
 - Updated T_J minimum and removed T_A [29](#)
 - Changed Lifetime POH from 20k to 100k. [29](#)
 - Updated T_J minimum [30](#)
 - Updated test condition temperatures for [31](#)
 - Added conditions [34](#)
 - Added conditions [36](#)
 - Added test conditions [41](#)
 - Added conditions [42](#)
 - Added conditions [47](#)
 - Added test conditions [50](#)
 - Added test conditions [54](#)
 - Updated *Glitch Filter Timing Specifications* table. [56](#)
 - Updated the minimum timing for ETMDATA parameters to show new orderable part number [97](#)
 - Added conditions [98](#)
 - Added conditions [100](#)
 - Added conditions to [Table 7-8](#) [108](#)
 - Added conditions [109](#)
 - Added conditions [110](#)
 - Added conditions for [Table 7-11](#) [115](#)
 - Added conditions for [Table 7-12](#) [116](#)
 - Added conditions for t_{pw} [120](#)
 - Added conditions for [Table 7-17](#) [121](#)
 - Added conditions for [Table 7-24](#) [132](#)
 - Added conditions to [Table 7-25](#) [135](#)
 - Added conditions to [Table 7-26](#) [137](#)
 - Added conditions to [Table 7-27](#) [139](#)
 - Added conditions to transition time [144](#)
-

Changes from Revision A (October 2013) to Revision B Page

- Changed Operation Life Derating Chart [30](#)
-

3 Device Comparison Table

3.1 Device Comparison

To compare the TMS570LS3137-EP with other devices, see [Compare](#) on the product folder.

4 Pin Configuration and Functions

4.1 Pin Diagrams

337-Ball Grid Array
GWT BGA Package
Top View

	A	B	C	D	E	F	G	H	J	K	L	M	N	P	R	T	U	V	W		
19	VSS	VSS	TMS	N2HET1 [10]	MIBSPI5 NCS[0]	MIBSPI1 SIMO	MIBSPI1 NENA	MIBSPI5 CLK	MIBSPI5 SIMO[0]	N2HET1 [28]	DMM_DATA[0]	CAN3RX	AD1EVT	AD1IN[15] / AD2IN[15]	AD1IN[22] / AD2IN[06]	AD1IN [06]	AD1IN[11] / AD2IN[11]	VSSAD	VSSAD	19	
18	VSS	TCK	TDO	nTRST	N2HET1 [08]	MIBSPI1 CLK	MIBSPI1 SOMI	MIBSPI5 NENA	MIBSPI5 SOMI[0]	N2HET1 [0]	DMM_DATA[1]	CAN3TX	NC	AD1IN[08] / AD2IN[08]	AD1IN[14] / AD2IN[14]	AD1IN[13] / AD2IN[13]	AD1IN [04]	AD1IN [02]	VSSAD	18	
17	TDI	RST	EMIF_ADDR[21]	EMIF_nWE	MIBSPI5 SOMI[1]	DMM_CLK	MIBSPI5 SIMO[3]	MIBSPI5 SIMO[2]	N2HET1 [31]	EMIF_nCS[3]	EMIF_nCS[2]	EMIF_nCS[4]	EMIF_nCS[0]	NC	AD1IN [05]	AD1IN [03]	AD1IN[10] / AD2IN[10]	AD1IN [01]	AD1IN[09] / AD2IN[09]	17	
16	RTCK	FRAY_TXEN1	EMIF_ADDR[20]	EMIF_BA[1]	MIBSPI5 SIMO[1]	DMM_NENA	MIBSPI5 SOMI[3]	MIBSPI5 SOMI[2]	DMM_SYNC	NC	NC	NC	NC	NC	AD1IN[23] / AD2IN[07]	AD1IN[12] / AD2IN[12]	AD1IN[19] / AD2IN[03]	ADREFLO	VSSAD	16	
15	FRAY_RX1	FRAY_TX1	EMIF_ADDR[19]	EMIF_ADDR[18]	ETM_DATA[06]	ETM_DATA[05]	ETM_DATA[04]	ETM_DATA[03]	ETM_DATA[02]	ETM_DATA[16] / EMIF_DATA[0]	ETM_DATA[17] / EMIF_DATA[1]	ETM_DATA[18] / EMIF_DATA[2]	ETM_DATA[19] / EMIF_DATA[3]	NC	NC	AD1IN[21] / AD2IN[05]	AD1IN[20] / AD2IN[04]	ADREFHI	VCCAD	15	
14	N2HET1 [26]	nERROR	EMIF_ADDR[17]	EMIF_ADDR[16]	ETM_DATA[07]	VCCIO	VCCIO	VCCIO	VCC	VCC	VCCIO	VCCIO	VCCIO	VCCIO	NC	NC	AD1IN[18] / AD2IN[02]	AD1IN [07]	AD1IN [0]	14	
13	N2HET1 [17]	N2HET1 [19]	EMIF_ADDR[15]	NC	ETM_DATA[12] / EMIF_BA[0]	VCCIO								VCCIO	ETM_DATA[01]	NC	AD1IN[17] / AD2IN[01]	AD1IN[16] / AD2IN[0]	NC	13	
12	ECLK	N2HET1 [04]	EMIF_ADDR[14]	NC	ETM_DATA[13] / EMIF_nOE	VCCIO		VSS	VSS	VCC	VSS	VSS		VCCIO	ETM_DATA[0]	MIBSPI5 NCS[3]	NC	NC	NC	12	
11	N2HET1 [14]	N2HET1 [30]	EMIF_ADDR[13]	NC	ETM_DATA[14] / EMIF_nDQM[1]	VCCIO		VSS	VSS	VSS	VSS	VSS		VCCPLL	ETM_TRACE_CTL	NC	NC	NC	NC	11	
10	CAN1TX	CAN1RX	EMIF_ADDR[12]	NC	ETM_DATA[15] / EMIF_nDQM[0]	VCC		VCC	VSS	VSS	VSS	VCC		VCC	ETM_TRACE_CLKOUT	NC	NC	MIBSPI3 NCS[0]	GIOB[3]	10	
9	N2HET1 [27]	FRAY_TXEN2	EMIF_ADDR[11]	NC	ETM_DATA[08] / EMIF_ADDR[5]	VCC		VSS	VSS	VSS	VSS	VSS		VCCIO	ETM_TRACE_CLKIN	NC	NC	MIBSPI3 CLK	MIBSPI3 NENA	9	
8	FRAY_RX2	FRAY_TX2	EMIF_ADDR[10]	NC	ETM_DATA[09] / EMIF_ADDR[4]	VCCP		VSS	VSS	VCC	VSS	VSS		VCCIO	ETM_DATA[31] / EMIF_DATA[15]	NC	NC	MIBSPI3 SOMI	MIBSPI3 SIMO	8	
7	LINRX	LINTX	EMIF_ADDR[9]	NC	ETM_DATA[10] / EMIF_ADDR[3]	VCCIO								VCCIO	ETM_DATA[30] / EMIF_DATA[14]	NC	NC	N2HET1 [09]	nPORRST	7	
6	GIOA[4]	MIBSPI5 NCS[1]	EMIF_ADDR[8]	NC	ETM_DATA[11] / EMIF_ADDR[2]	VCCIO	VCCIO	VCCIO	VCCIO	VCC	VCC	VCCIO	VCCIO	VCCIO	VCCIO	ETM_DATA[29] / EMIF_DATA[13]	NC	NC	N2HET1 [05]	MIBSPI5 NCS[2]	6
5	GIOA[0]	GIOA[5]	EMIF_ADDR[7]	EMIF_ADDR[1]	ETM_DATA[20] / EMIF_DATA[4]	ETM_DATA[21] / EMIF_DATA[5]	ETM_DATA[22] / EMIF_DATA[6]	FLTP2	FLTP1	ETM_DATA[23] / EMIF_DATA[7]	ETM_DATA[24] / EMIF_DATA[8]	ETM_DATA[25] / EMIF_DATA[9]	ETM_DATA[26] / EMIF_DATA[10]	ETM_DATA[27] / EMIF_DATA[11]	ETM_DATA[28] / EMIF_DATA[12]	NC	NC	MIBSPI3 NCS[1]	N2HET1 [02]	5	
4	N2HET1 [16]	N2HET1 [12]	EMIF_ADDR[6]	EMIF_ADDR[0]	NC	NC	NC	N2HET1 [21]	N2HET1 [23]	NC	NC	NC	NC	NC	EMIF_nCAS	NC	NC	NC	NC	4	
3	N2HET1 [29]	N2HET1 [22]	MIBSPI3 NCS[3]	SPI2 NENA	N2HET1 [11]	MIBSPI1 NCS[1]	MIBSPI1 NCS[2]	GIOA[6]	MIBSPI1 NCS[3]	EMIF_CLK	EMIF_CKE	N2HET1 [25]	SPI2 NCS[0]	EMIF_nWAIT	EMIF_nRAS	NC	NC	NC	N2HET1 [06]	3	
2	VSS	MIBSPI3 NCS[2]	GIOA[1]	SPI2 SOMI	SPI2 CLK	GIOB[2]	GIOB[5]	CAN2TX	GIOB[6]	GIOB[1]	KELVIN_GND	GIOB[0]	N2HET1 [13]	N2HET1 [20]	MIBSPI1 NCS[0]	NC	TEST	N2HET1 [01]	VSS	2	
1	VSS	VSS	GIOA[2]	SPI2 SIMO	GIOA[3]	GIOB[7]	GIOB[4]	CAN2RX	N2HET1 [18]	OSCIN	OSCOUT	GIOA[7]	N2HET1 [15]	N2HET1 [24]	NC	N2HET1 [07]	N2HET1 [03]	VSS	VSS	1	

NOTE: Balls can have multiplexed functions. Only the default function is depicted in above diagram, except for the EMIF signals that are multiplexed with ETM signals.

4.1.1 Pin Attributes

4.1.1.1 identifies the external signal names, the associated pin/ball numbers along with the mechanical package designator, the pin/ball type (Input, Output, IO, Power or Ground), whether the pin/ball has any internal pullup/pulldown, whether the pin/ball can be configured as a GPIO, and a functional pin/ball description. The first signal name listed is the primary function for that terminal. The signal name in Bold is the function being described. Refer to the TMS570LS31X/21X Technical Reference Manual ([SPNU499](#)) for information on how to select between different multiplexed functions.

NOTE

All I/O signals except nRST are configured as inputs while nPORRST is low and immediately after nPORRST goes High.

All output-only signals are configured as inputs while nPORRST is low, and are configured as outputs immediately after nPORRST goes High.

While nPORRST is low, the input buffers are disabled, and the output buffers are tri-stated.

In the Pin Functions table below, the "Default Pull State" is the state of the pullup or pulldown while nPORRST is low and immediately after nPORRST goes High. The default pull direction may change when software configures the pin for an alternate function. The "Pull Type" is the type of pull asserted when the signal name in bold is enabled for the given pin.

4.1.1.1 GWT Package

4.1.1.1.1 Multi-Buffered Analog-to-Digital Converters (MibADC)

Table 4-1. GWT Multi-Buffered Analog-to-Digital Converters (MibADC1, MibADC2)

Pin		Signal Type	Default Pull State	Pull Type	Description	
Signal Name	337 GWT					
ADREFHI ⁽¹⁾	V15	Input	-	None	ADC high reference supply	
ADREFLO ⁽¹⁾	V16	Input			ADC low reference supply	
VCCAD ⁽¹⁾	W15	Power			Operating supply for ADC	
VSSAD	V19	Ground	-	None	ADC supply power	
	W16					
	W18					
	W19					
AD1EVT	N19	I/O	Pull Down	Programmable, 20uA	ADC1 event trigger input, or GPIO	
MIBSPI3NCS[0]/AD2EVT/GIOB[2]/N2HET2_PIN_nDIS		V10	I/O	Pull Up	Programmable, 20uA	ADC2 event trigger input, or GPIO
AD1IN[0]	W14	Input	-	None	ADC1 analog input	
AD1IN[1]	V17					
AD1IN[2]	V18					
AD1IN[3]	T17					
AD1IN[4]	U18					
AD1IN[5]	R17					
AD1IN[6]	T19					
AD1IN[7]	V14					
AD1IN[8] / AD2IN[8]	P18					Input
AD1IN[9] / AD2IN[9]	W17					
AD1IN[10] / AD2IN[10]	U17					
AD1IN[11] / AD2IN[11]	U19					
AD1IN[12] / AD2IN[12]	T16					
AD1IN[13] / AD2IN[13]	T18					
AD1IN[14] / AD2IN[14]	R18					
AD1IN[15] / AD2IN[15]	P19					
AD1IN[16] / AD2IN[0]	V13					
AD1IN[17] / AD2IN[1]	U13					
AD1IN[18] / AD2IN[2]	U14					
AD1IN[19] / AD2IN[3]	U16					
AD1IN[20] / AD2IN[4]	U15					
AD1IN[21] / AD2IN[5]	T15					
AD1IN[22] / AD2IN[6]	R19					
AD1IN[23] / AD2IN[7]	R16					

(1) The ADREFHI, ADREFLO, VCCAD and VSSAD connections are common for both ADC cores.

4.1.1.1.2 Enhanced High-End Timer Modules (N2HET)
Table 4-2. GWT Enhanced High-End Timer Modules (N2HET)

Pin		Signal Type	Default Pull State	Pull Type	Description
Signal Name	337 GWT				
N2HET1[0]/SPI4CLK	K18	I/O	Pull Down	Programmable, 20uA	N2HET1 time input capture or output compare, or GIO. Each terminal has a suppression filter that ignores input pulses smaller than a programmable duration.
N2HET1[1]/SPI4NENA/N2HET2[8]	V2				
N2HET1[2]/SPI4SIMO[0]	W5				
N2HET1[3]/SPI4NCS[0]/N2HET2[10]	U1				
N2HET1[4]	B12				
N2HET1[5]/SPI4SOMI[0]/N2HET2[12]	V6				
N2HET1[6]/SCIRX	W3				
N2HET1[7]/N2HET2[14]	T1				
N2HET1[8]/MIBSPI1SIMO[1]	E18				
N2HET1[9]/N2HET2[16]	V7				
N2HET1[10]	D19				
N2HET1[11]/MIBSPI3NCS[4]/N2HET2[18]	E3				
N2HET1[12]	B4				
N2HET1[13]/SCITX	N2				
N2HET1[14]	A11				
N2HET1[15]/MIBSPI1NCS[4]	N1				
N2HET1[16]	A4				
N2HET1[17]	A13				
N2HET1[18]	J1				
N2HET1[19]	B13				
N2HET1[20]	P2				
N2HET1[21]	H4				
N2HET1[22]	B3				
N2HET1[23]	J4				
N2HET1[24]/MIBSPI1NCS[5]	P1				
N2HET1[25]	M3				
N2HET1[26]/	A14				
N2HET1[27]	A9				
N2HET1[28]/	K19				
N2HET1[29]	A3				
N2HET1[30]	B11				
N2HET1[31]	J17				
GIOA[5]/EXTCLKIN/N2HET1_PIN_nDIS	B5	I/O	Pull Down	Programmable, 20uA	

Table 4-2. GWT Enhanced High-End Timer Modules (N2HET) (continued)

Pin		Signal Type	Default Pull State	Pull Type	Description
Signal Name	337 GWT				
GIOA[2]/N2HET2[0]	C1	I/O	Pull Down	Programmable, 20uA	N2HET2 time input capture or output compare, or GIO. Each terminal has a suppression filter that ignores input pulses smaller than a programmable duration.
EMIF_ADDR[0]/N2HET2[1]	D4				
GIOA[3]/N2HET2[2]	E1				
EMIF_ADDR[1]/N2HET2[3]	D5				
GIOA[6]/N2HET2[4]	H3				
EMIF_BA[1]/N2HET2[5]	D16				
GIOA[7]/N2HET2[6]	M1				
EMIF_nCS[0]/RTP_DATA[15]/N2HET2[7]	N17				
N2HET1[1]/SPI4NENA/N2HET2[8]	V2				
EMIF_nCS[3]/RTP_DATA[14]/N2HET2[9]	K17				
N2HET1[3]/SPI4NCS[0]/N2HET2[10]	U1				
EMIF_ADDR[6]/RTP_DATA[13]/N2HET2[11]	C4				
N2HET1[5]/SPI4SOMI[0]/N2HET2[12]	V6				
EMIF_ADDR[7]/RTP_DATA[12]/N2HET2[13]	C5				
N2HET1[7]/N2HET2[14]	T1				
EMIF_ADDR[8]/RTP_DATA[11]/N2HET2[15]	C6				
N2HET1[9]/N2HET2[16]	V7				
N2HET1[11]/MIBSPI3NCS[4]/N2HET2[18]	E3				
MIBSPI3NCS[0]/AD2EVT/GIOB[2]/N2HET2_PIN_nDIS	V10	I/O	Pull Up	Programmable, 20uA	

4.1.1.1.3 General-Purpose Input / Output (GPIO)

Table 4-3. GWT General-Purpose Input / Output (GPIO)

Pin		Signal Type	Default Pull State	Pull Type	Description
Signal Name	337 GWT				
GIOA[0]	A5	I/O	Pull Down	Programmable, 20uA	General-purpose I/O. All GPIO terminals are capable of generating interrupts to the CPU on rising / falling / both edges.
GIOA[1]	C2				
GIOA[2]/N2HET2[0]	C1				
GIOA[3]/N2HET2[2]	E1				
GIOA[4]	A6				
GIOA[5]/EXTCLKIN/N2HET1_PIN_nDIS	B5				
GIOA[6]/N2HET2[4]	H3				
GIOA[7]/N2HET2[6]	M1				
GIOB[0]	M2				
GIOB[1]	K2				
GIOB[2]	F2				
GIOB[3]	W10				
GIOB[4]	G1				
GIOB[5]	G2				
GIOB[6]	J2				
GIOB[7]	F1				
MIBSPI3NCS[0]/AD2EVT/GIOB[2]/N2HET2_PIN_nDIS	V10		Pull Up	Fixed 20uA pull down	GIOB[2] is input only on this terminal. When GIOB[2] function is selected, the pull is a fixed pull down

4.1.1.1.4 FlexRay Interface Controller (FlexRay)

Table 4-4. FlexRay Interface Controller (FlexRay)

Pin		Signal Type	Default Pull State	Pull Type	Description
Signal Name	337 GWT				
FRAYRX1	A15	Input	Pull Up	Fixed, 100uA	FlexRay data receive (channel 1)
FRAYTX1	B15	Output	None	-	FlexRay data transmit (channel 1)
FRAYTXEN1	B16	Output			FlexRay transmit enable (channel 1)
FRAYRX2	A8	Input	Pull Up	Fixed, 100uA	FlexRay data receive (channel 2)
FRAYTX2	B8	Output	None	-	FlexRay data transmit (channel 2)
FRAYTXEN2	B9	Output			FlexRay transmit enable (channel 2)

4.1.1.1.5 Controller Area Network Controllers (DCAN)

Table 4-5. GWT Controller Area Network Controllers (DCAN)

Pin		Signal Type	Default Pull State	Pull Type	Description
Signal Name	337 GWT				
CAN1RX	B10	I/O	Pull Up	Programmable, 20uA	CAN1 receive, or GPIO
CAN1TX	A10				CAN1 transmit, or GPIO
CAN2RX	H1				CAN2 receive, or GPIO
CAN2TX	H2				CAN2 transmit, or GPIO
CAN3RX	M19				CAN3 receive, or GPIO
CAN3TX	M18				CAN3 transmit, or GPIO

4.1.1.1.6 Local Interconnect Network Interface Module (LIN)

Table 4-6. GWT Local Interconnect Network Interface Module (LIN)

Pin		Signal Type	Default Pull State	Pull Type	Description
Signal Name	337 GWT				
LINRX	A7	I/O	Pull Up	Programmable, 20uA	LIN receive, or GPIO
LINTX	B7				LIN transmit, or GPIO

4.1.1.1.7 Standard Serial Communication Interface (SCI)

Table 4-7. GWT Standard Serial Communication Interface (SCI)

Pin		Signal Type	Default Pull State	Pull Type	Description
Signal Name	337 GWT				
N2HET1[6]/SCIRX	W3	I/O	Pull Down	Programmable, 20uA	SCI receive, or GPIO
N2HET1[13]/SCITX	N2				SCI transmit, or GPIO

4.1.1.1.8 Inter-Integrated Circuit Interface Module (I2C)

Table 4-8. GWT Inter-Integrated Circuit Interface Module (I2C)

Pin		Signal Type	Default Pull State	Pull Type	Description
Signal Name	337 GWT				
MIBSPI3NCS[2]/I2C_SDA/N2HET1[27]	B2	I/O	Pull Up	Programmable, 20uA	I2C serial data, or GPIO
MIBSPI3NCS[3]/I2C_SCL/N2HET1[29]	C3				I2C serial clock, or GPIO

4.1.1.1.9 Standard Serial Peripheral Interface (SPI)

Table 4-9. GWT Standard Serial Peripheral Interface (SPI)

Pin		Signal Type	Default Pull State	Pull Type	Description
Signal Name	337 GWT				
SPI2CLK	E2	I/O	Pull Up	Programmable, 20uA	SPI2 clock, or GPIO
SPI2NCS[0]	N3				SPI2 chip select, or GPIO
SPI2NENA/SPI2NCS[1]	D3				SPI2 chip select, or GPIO
SPI2NENA/SPI2NCS[1]	D3				SPI2 enable, or GPIO
SPI2SIMO[0]	D1				SPI2 slave-input master-output, or GPIO
SPI2SOMI[0]	D2				SPI2 slave-output master-input, or GPIO
N2HET1[0]/SPI4CLK	K18	I/O	Pull Down	Programmable, 20uA	SPI4 clock, or GPIO
N2HET1[3]/SPI4NCS[0]/N2HET2[10]	U1				SPI4 chip select, or GPIO
N2HET1[1]/SPI4NENA/N2HET2[8]	V2				SPI4 enable, or GPIO
N2HET1[2]/SPI4SIMO[0]	W5				SPI4 slave-input master-output, or GPIO
N2HET1[5]/SPI4SOMI[0]/N2HET2[12]	V6				SPI4 slave-output master-input, or GPIO

4.1.1.1.10 Multi-Buffered Serial Peripheral Interface Modules (MibSPI)

Table 4-10. GWT Multi-Buffered Serial Peripheral Interface Modules (MibSPI)

Pin		Signal Type	Default Pull State	Pull Type	Description	
Signal Name	337 GWT					
MIBSPI1CLK	F18	I/O	Pull Up	Programmable, 20uA	MibSPI1 clock, or GPIO	
MIBSPI1NCS[0]/MIBSPI1SOMI[1]	R2				MibSPI1 chip select, or GPIO	
MIBSPI1NCS[1]/N2HET1[17]	F3					
MIBSPI1NCS[2]/N2HET1[19]	G3					
MIBSPI1NCS[3]/N2HET1[21]	J3					
N2HET1[15]/MIBSPI1NCS[4]	N1		Pull Down	Programmable, 20uA	MibSPI1 chip select, or GPIO	
N2HET1[24]/MIBSPI1NCS[5]	P1					
MIBSPI1NENA/N2HET1[23]	G19		Pull Up	Programmable, 20uA	MibSPI1 enable, or GPIO	
MIBSPI1SIMO[0]	F19				MibSPI1 slave-in master-out, or GPIO	
N2HET1[8]/MIBSPI1SIMO[1]	E18		Pull Down	Programmable, 20uA	MibSPI1 slave-in master-out, or GPIO	
MIBSPI1SOMI[0]	G18		Pull Up	Programmable, 20uA	MibSPI1 slave-out master-in, or GPIO	
MIBSPI1NCS[0]/MIBSPI1SOMI[1]	R2					
MIBSPI3CLK	V9	I/O	Pull Up	Programmable, 20uA	MibSPI3 clock, or GPIO	
MIBSPI3NCS[0]/AD2EVT/GIOB[2]/N2HET2_PIN_nDIS	V10				MibSPI3 chip select, or GPIO	
MIBSPI3NCS[1]/N2HET1[25]/MDCLK	V5					
MIBSPI3NCS[2]/I2C_SDA/N2HET1[27]	B2					
MIBSPI3NCS[3]/I2C_SCL/N2HET1[29]	C3					
N2HET1[11]/MIBSPI3NCS[4]/N2HET2[18]	E3		Pull Down	Programmable, 20uA	MibSPI3 chip select, or GPIO	
MIBSPI3NENA/MIBSPI3NCS[5]/N2HET1[31]	W9		Pull Up	Programmable, 20uA	MibSPI3 chip select, or GPIO	
MIBSPI3NENA/MIBSPI3NCS[5]/N2HET1[31]	W9				MibSPI3 enable, or GPIO	
MIBSPI3SIMO[0]	W8				MibSPI3 slave-in master-out, or GPIO	
MIBSPI3SOMI[0]	V8				MibSPI3 slave-out master-in, or GPIO	
MIBSPI5CLK/DMM_DATA[4]	H19	I/O	Pull Up	Programmable, 20uA	MibSPI5 clock, or GPIO	
MIBSPI5NCS[0]/DMM_DATA[5]	E19				MibSPI5 chip select, or GPIO	
MIBSPI5NCS[1]/DMM_DATA[6]	B6					
MIBSPI5NCS[2]/DMM_DATA[2]	W6					
MIBSPI5NCS[3]/DMM_DATA[3]	T12					
MIBSPI5NENA/DMM_DATA[7]/	H18					MibSPI5 enable, or GPIO
MIBSPI5SIMO[0]/DMM_DATA[8]	J19					MibSPI5 slave-in master-out, or GPIO
MIBSPI5SIMO[1]/DMM_DATA[9]	E16					
MIBSPI5SIMO[2]/DMM_DATA[10]	H17					
MIBSPI5SIMO[3]/DMM_DATA[11]	G17					
MIBSPI5SOMI[0]/DMM_DATA[12]	J18					
MIBSPI5SOMI[1]/DMM_DATA[13]	E17					
MIBSPI5SOMI[2]/DMM_DATA[14]	H16					
MIBSPI5SOMI[3]/DMM_DATA[15]	G16					

4.1.1.1.11 Ethernet Controller
Table 4-11. GWT Ethernet Controller: MDIO Interface

Pin		Signal Type	Default Pull State	Pull Type	Description
Signal Name	337 GWT				
MIBSPI3NCS[1]/N2HET1[25]/MDCLK	V5	Output	Pull Up	-	Serial clock output
MIBSPI1NCS[2]/N2HET1[19]/MDIO	G3	I/O	Pull Up	Fixed, 20uA	Serial data input/output

Table 4-12. GWT Ethernet Controller: Reduced Media Independent Interface (RMII)

Pin		Signal Type	Default Pull State	Pull Type	Description
Signal Name	337 GWT				
N2HET1[12]/MII_CRS/RMII_CRS_DV	B4	Input	Pull Down	Fixed, 20uA	RMII carrier sense and data valid
N2HET1[28]/MII_RX_CLK/RMII_REFCLK/MII_RX_AVCLK4	K19				RMII synchronous reference clock for receive, transmit and control interface
AD1EVT/MII_RX_ER/RMII_RX_ER	N19				RMII receive error
N2HET1[24]/MIBSPI1NCS[5]/MII_RXD[0]/RMII_RXD[0]	P1				RMII receive data
N2HET1[26]/MII_RXD[1]/RMII_RXD[1]	A14	Output	Pull Up	-	RMII transmit data
MIBSPI5SOMI[0]/DMM_DATA[12]/MII_TXD[0]/RMII_TXD[0]	J18				RMII transmit data
MIBSPI5SIMO[0]/DMM_DATA[8]/MII_TXD[1]/RMII_TXD[1]	J19				RMII transmit data
MIBSPI5CLK/DMM_DATA[4]/MII_TXEN/RMII_TXEN	H19				RMII transmit enable

Table 4-13. GWT Ethernet Controller: Media Independent Interface (MII)

Pin		Signal Type	Default Pull State	Pull Type	Description
Signal Name	337 GWT				
MIBSPI1NCS[1]/N2HET1[17]/MII_COL	F3	Input	Pull Up	-	Collision detect
N2HET1[12]/MII_CRS/RMII_CRS_DV	B4				Pull Down
N2HET1[28]/MII_RX_CLK/RMII_REFCLK/MII_RX_AVCLK4	K19	I/O	Pull Down	-	MII output receive clock
N2HET1[30]/MII_RX_DV	B11	Input	Pull Down	Fixed, 20uA	Received data valid
AD1EVT/MII_RX_ER/RMII_RX_ER	N19				Receive error
N2HET1[28]/MII_RX_CLK/RMII_REFCLK/MII_RX_AVCLK4	K19	I/O	Pull Down	Fixed, 20uA	Receive clock
N2HET1[24]/MIBSPI1NCS[5]/MII_RXD[0]/RMII_RXD[0]	P1				Receive data
N2HET1[26]/MII_RXD[1]/RMII_RXD[1]	A14	Input	Pull Up	Fixed, 20uA	Receive data
MIBSPI1NENA/N2HET1[23]/MII_RXD[2]	G19				Receive data
MIBSPI5NENA/DMM_DATA[7]/	H18				Receive data
N2HET1[10]/MII_TX_CLK/MII_TX_AVCLK4	D19	I/O	Pull Down	-	MII output transmit clock
N2HET1[10]/MII_TX_CLK/MII_TX_AVCLK4	D19				Transmit clock
MIBSPI5SOMI[0]/DMM_DATA[12]/RMII_TXD[0]	J18	Output	Pull Up	-	Transmit data
MIBSPI5SIMO[0]/DMM_DATA[8]/RMII_TXD[1]	J19				Transmit data
MIBSPI1NCS[0]/MIBSPI1SOMI[1]/MII_TXD[2]	R2				Transmit data
N2HET1[8]/MIBSPI1SIMO[1]/MII_TXD[3]	E18				Pull Down
MIBSPI5CLK/DMM_DATA[4]/RMII_TXEN	H19		Pull Up	-	Transmit enable

4.1.1.1.12 External Memory Interface (EMIF)

Table 4-14. External Memory Interface (EMIF)

Pin		Signal Type	Default Pull State	Pull Type	Description
Signal Name	337 GWT				
EMIF_CKE	L3	Output	Pull Down	Programmable, 20uA	EMIF Clock Enable
EMIF_CLK	K3	I/O			EMIF clock. This is an output signal in functional mode. It is gated off by default, so that the signal is tri-stated. PINMUX29[8] must be cleared to enable this output.
EMIF_nWE/EMIF_RNW	D17	Output	Pull Up	Programmable, 20uA	EMIF Read-Not-Write
ETMDATA[13]/EMIF_nOE	E12		Pull Down	Programmable, 20uA	EMIF Output Enable
EMIF_nWAIT	P3	I/O	Pull Up	Fixed, 20uA	EMIF Extended Wait Signal
EMIF_nWE/EMIF_RNW	D17	Output	Pull Up	Programmable, 20uA	EMIF Write Enable.
EMIF_nCAS	R4	Output			EMIF column address strobe
EMIF_nRAS	R3	Output			EMIF row address strobe
EMIF_nCS[0]/RTP_DATA[15]/N2HET2[7]	N17	Output	Pull Down	Programmable, 20uA	EMIF chip select, SDRAM
EMIF_nCS[2]	L17	Output	Pull Up	Programmable, 20uA	EMIF chip selects, asynchronous This applies to chip selects 2, 3 and 4
EMIF_nCS[3]/RTP_DATA[14]/N2HET2[9]	K17	Output	Pull Down	Programmable, 20uA	
EMIF_nCS[4]/RTP_DATA[7]	M17	Output	Pull Up	Programmable, 20uA	

Table 4-14. External Memory Interface (EMIF) (continued)

Pin		Signal Type	Default Pull State	Pull Type	Description
Signal Name	337 GWT				
ETMDATA[15]/EMIF_nDQM[0]	E10	Output	Pull Down	Programmable, 20uA	EMIF Data Mask or Write Strobe. Data mask for SDRAM devices, write strobe for connected asynchronous devices.
ETMDATA[14]/EMIF_nDQM[1]	E11	Output			
ETMDATA[12]/EMIF_BA[0]	E13	Output	Pull Down	-	EMIF bank address or address line
EMIF_BA[1]/N2HET2[5]	D16	Output			EMIF bank address or address line
EMIF_ADDR[0]/N2HET2[1]	D4	Output			EMIF address
EMIF_ADDR[1]/N2HET2[3]	D5	Output			
ETMDATA[11]/EMIF_ADDR[2]	E6	Output			
ETMDATA[10]/EMIF_ADDR[3]	E7	Output			
ETMDATA[9]/EMIF_ADDR[4]	E8	Output			
ETMDATA[8]/EMIF_ADDR[5]	E9	Output			
EMIF_ADDR[6]/RTP_DATA[13]	C4	Output			
EMIF_ADDR[7]/RTP_DATA[12]	C5	Output			
EMIF_ADDR[8]/RTP_DATA[11]	C6	Output			
EMIF_ADDR[9]/RTP_DATA[10]	C7	Output			
EMIF_ADDR[10]/RTP_DATA[9]	C8	Output			
EMIF_ADDR[11]/RTP_DATA[8]	C9	Output			
EMIF_ADDR[12]/RTP_DATA[6]	C10	Output			
EMIF_ADDR[13]/RTP_DATA[5]	C11	Output			
EMIF_ADDR[14]/RTP_DATA[4]	C12	Output			
EMIF_ADDR[15]/RTP_DATA[3]	C13	Output			
EMIF_ADDR[16]/RTP_DATA[2]	D14	Output			
EMIF_ADDR[17]/RTP_DATA[1]	C14	Output			Pull Down
EMIF_ADDR[18]/RTP_DATA[0]	D15	Output			
EMIF_ADDR[19]/RTP_nENA	C15	Output			
EMIF_ADDR[20]/RTP_nSYNC	C16	Output			
EMIF_ADDR[21]/RTP_CLK	C17	Output			
ETMDATA[16]/EMIF_DATA[0]	K15	I/O	Pull Down	Fixed, 20uA	EMIF Data
ETMDATA[17]/EMIF_DATA[1]	L15	I/O			
ETMDATA[18]/EMIF_DATA[2]	M15	I/O			
ETMDATA[19]/EMIF_DATA[3]	N15	I/O			
ETMDATA[20]/EMIF_DATA[4]	E5	I/O			
ETMDATA[21]/EMIF_DATA[5]	F5	I/O			
ETMDATA[22]/EMIF_DATA[6]	G5	I/O			
ETMDATA[23]/EMIF_DATA[7]	K5	I/O			
ETMDATA[24]/EMIF_DATA[8]	L5	I/O			
ETMDATA[25]/EMIF_DATA[9]	M5	I/O			
ETMDATA[26]/EMIF_DATA[10]	N5	I/O			
ETMDATA[27]/EMIF_DATA[11]	P5	I/O			
ETMDATA[28]/EMIF_DATA[12]	R5	I/O			
ETMDATA[29]/EMIF_DATA[13]	R6	I/O			
ETMDATA[30]/EMIF_DATA[14]	R7	I/O			
ETMDATA[31]/EMIF_DATA[15]	R8	I/O			

4.1.1.1.13 Embedded Trace Macrocell for Cortex-R4F CPU (ETM-R4F)

Table 4-15. Embedded Trace Macrocell for Cortex-R4F CPU (ETM-R4F)

Pin		Signal Type	Default Pull State	Pull Type	Description
Signal Name	337 GWT				
ETMTRACECLKIN/EXTCLKIN2	R9	Input	Pull Down	Fixed, 20uA	ETM Trace Clock Input
ETMTRACECLKOUT	R10	Output	Pull Down	-	ETM Trace Clock Output
ETMTRACECTL	R11	Output	Pull Down	-	ETM trace control
ETMDATA[0]	R12				ETM data
ETMDATA[1]	R13				
ETMDATA[2]	J15				
ETMDATA[3]	H15				
ETMDATA[4]	G15				
ETMDATA[5]	F15				
ETMDATA[6]	E15				
ETMDATA[7]	E14				
ETMDATA[8]/EMIF_ADDR[5]	E9				
ETMDATA[9]/EMIF_ADDR[4]	E8				
ETMDATA[10]/EMIF_ADDR[3]	E7				
ETMDATA[11]/EMIF_ADDR[2]	E6				
ETMDATA[12]/EMIF_BA[0]	E13				
ETMDATA[13]/EMIF_nOE	E12				
ETMDATA[14]/EMIF_nDQM[1]	E11				
ETMDATA[15]/EMIF_nDQM[0]	E10				
ETMDATA[16]/EMIF_DATA[0]	K15				
ETMDATA[17]/EMIF_DATA[1]	L15				
ETMDATA[18]/EMIF_DATA[2]	M15				
ETMDATA[19]/EMIF_DATA[3]	N15				
ETMDATA[20]/EMIF_DATA[4]	E5				
ETMDATA[21]/EMIF_DATA[5]	F5				
ETMDATA[22]/EMIF_DATA[6]	G5				
ETMDATA[23]/EMIF_DATA[7]	K5				
ETMDATA[24]/EMIF_DATA[8]	L5				
ETMDATA[25]/EMIF_DATA[9]	M5				
ETMDATA[26]/EMIF_DATA[10]	N5				
ETMDATA[27]/EMIF_DATA[11]	P5				
ETMDATA[28]/EMIF_DATA[12]	R5				
ETMDATA[29]/EMIF_DATA[13]	R6				
ETMDATA[30]/EMIF_DATA[14]	R7				
ETMDATA[31]/EMIF_DATA[15]	R8				

4.1.1.1.14 RAM Trace Port (RTP)
Table 4-16. RAM Trace Port (RTP)

Pin		Signal Type	Default Pull State	Pull Type	Description
Signal Name	337 GWT				
EMIF_ADDR[21]/RTP_CLK	C17	I/O	Pull Down	Programmable, 20uA	RTP packet clock, or GPIO
EMIF_ADDR[19]/RTP_nENA	C15	I/O			RTP packet handshake, or GPIO
EMIF_ADDR[20]/RTP_nSYNC	C16	I/O			RTP synchronization, or GPIO
EMIF_ADDR[18]/RTP_DATA[0]	D15	I/O	Pull Down	Programmable, 20uA	RTP packet data, or GPIO
EMIF_ADDR[17]/RTP_DATA[1]	C14				
EMIF_ADDR[16]/RTP_DATA[2]	D14				
EMIF_ADDR[15]/RTP_DATA[3]	C13				
EMIF_ADDR[14]/RTP_DATA[4]	C12				
EMIF_ADDR[13]/RTP_DATA[5]	C11				
EMIF_ADDR[12]/RTP_DATA[6]	C10				
EMIF_nCS[4]/RTP_DATA[7]	M17				
EMIF_ADDR[11]/RTP_DATA[8]	C9				
EMIF_ADDR[10]/RTP_DATA[9]	C8				
EMIF_ADDR[9]/RTP_DATA[10]	C7	Pull Down	Programmable, 20uA		
EMIF_ADDR[8]/RTP_DATA[11]	C6				
EMIF_ADDR[7]/RTP_DATA[12]	C5				
EMIF_ADDR[6]/RTP_DATA[13]	C4				
EMIF_nCS[0]/RTP_DATA[15]/N2HET2[7]	N17				
EMIF_nCS[3]/RTP_DATA[14]/N2HET2[9]	K17				

4.1.1.15 Data Modification Module (DMM)

Table 4-17. Data Modification Module (DMM)

Pin		Signal Type	Default Pull State	Pull Type	Description
Signal Name	337 GWT				
DMM_CLK	F17	I/O	Pull Up	Programmable, 20uA	DMM clock, or GPIO
DMM_nENA	F16				DMM handshake, or GPIO
DMM_SYNC	J16				DMM synchronization, or GPIO
DMM_DATA[0]	L19				DMM data, or GPIO
DMM_DATA[1]	L18				
MIBSPI5NCS[2]/DMM_DATA[2]	W6				
MIBSPI5NCS[3]/DMM_DATA[3]	T12				
MIBSPI5CLK/DMM_DATA[4]	H19				
MIBSPI5NCS[0]/DMM_DATA[5]	E19				
MIBSPI5NCS[1]/DMM_DATA[6]	B6				
MIBSPI5NENA/DMM_DATA[7]	H18				
MIBSPI5SIMO[0]/DMM_DATA[8]	J19				
MIBSPI5SIMO[1]/DMM_DATA[9]	E16				
MIBSPI5SIMO[2]/DMM_DATA[10]	H17				
MIBSPI5SIMO[3]/DMM_DATA[11]	G17				
MIBSPI5SOMI[0]/DMM_DATA[12]	J18				
MIBSPI5SOMI[1]/DMM_DATA[13]	E17				
MIBSPI5SOMI[2]/DMM_DATA[14]	H16				
MIBSPI5SOMI[3]/DMM_DATA[15]	G16				

4.1.1.1.16 System Module Interface

Table 4-18. GWT System Module Interface

Pin		Signal Type	Default Pull State	Pull Type	Description
Signal Name	337 GWT				
nPORRST	W7	Input	Pull Down	100uA	Power-on reset, cold reset External power supply monitor circuitry must drive nPORRST low when any of the supplies to the microcontroller fall out of the specified range. This terminal has a glitch filter. See Section 6.8 .
nRST	B17	I/O	Pull Up	100uA	System reset, warm reset, bidirectional. The internal circuitry indicates any reset condition by driving nRST low. The external circuitry can assert a system reset by driving nRST low. To ensure that an external reset is not arbitrarily generated, TI recommends that an external pull-up resistor is connected to this terminal. This terminal has a glitch filter. See Section 6.8 .
nERROR	B14	I/O	Pull Down	20uA	ESM Error Signal Indicates error of high severity. See Section 6.18 .

4.1.1.1.17 Clock Inputs and Outputs

Table 4-19. GWT Clock Inputs and Outputs

Pin		Signal Type	Default Pull State	Pull Type	Description
Signal Name	337 GWT				
OSCIN	K1	Input	-	-	From external crystal/resonator, or external clock input
KELVIN_GND	L2	Input			Kelvin ground for oscillator
OSCOU	L1	Output			To external crystal/resonator
ECLK	A12	I/O	Pull Down	Programmable, 20uA	External prescaled clock output, or GIO.
GIOA[5]/EXTCLKIN/N2HET1_PIN_nDIS	B5	Input	Pull Down	20uA	External clock input #1
ETMTRACECLKIN/EXTCLKIN2	R9	Input			External clock input #2
VCCPLL	P11	1.2V Power		-	Dedicated core supply for PLL's

4.1.1.1.18 Test and Debug Modules Interface

Table 4-20. GWT Test and Debug Modules Interface

Pin		Signal Type	Default Pull State	Pull Type	Description
Signal Name	337 GWT				
TEST	U2	I/O	Pull Down	Fixed, 100uA	Test enable
nTRST	D18	Input			JTAG test hardware reset
RTCK	A16	Output	-	None	JTAG return test clock
TCK	B18	Input	Pull Down	Fixed, 100uA	JTAG test clock
TDI	A17	I/O	Pull Up		JTAG test data in
TDO	C18	I/O	Pull Down		JTAG test data out
TMS	C19	I/O	Pull Up		JTAG test select

4.1.1.1.19 Flash Supply and Test Pads

Table 4-21. GWT Flash Supply and Test Pads

Pin		Signal Type	Default Pull State	Pull Type	Description
Signal Name	337 GWT				
VCCP	F8	3.3V Power	-	None	Flash pump supply
FLTP1	J5				Flash test pads. These terminals are reserved for TI use only. For proper operation these terminals must connect only to a test pad or not be connected at all [no connect (NC)].
FLTP2	H5				

4.1.1.1.20 No Connects
Table 4-22. No Connects

Pin		Signal Type	Default Pull State	Pull Type	Description
Signal Name	337 GWT				
NC	A8	-	-	-	No Connects. These balls are not connected to any internal logic and can be connected to the PCB ground without affecting the functionality of the device. Any other ball marked as "NC" may be internally connected to some functionality. It is recommended for such balls to be left unconnected.
NC	B8	-	-	-	
NC	B9	-	-	-	
NC	D6	-	-	-	
NC	D7	-	-	-	
NC	D8	-	-	-	
NC	D9	-	-	-	
NC	D10	-	-	-	
NC	D11	-	-	-	
NC	D12	-	-	-	
NC	D13	-	-	-	
NC	E4	-	-	-	
NC	F4	-	-	-	
NC	G4	-	-	-	
NC	K4	-	-	-	
NC	K16	-	-	-	
NC	L4	-	-	-	
NC	L16	-	-	-	
NC	M4	-	-	-	
NC	M16	-	-	-	
NC	N4	-	-	-	
NC	N16	-	-	-	
NC	N18	-	-	-	
NC	P4	-	-	-	
NC	P15	-	-	-	
NC	P16	-	-	-	
NC	P17	-	-	-	
NC	R1	-	-	-	
NC	R14	-	-	-	
NC	R15	-	-	-	
NC	T3	-	-	-	
NC	T4	-	-	-	
NC	T5	-	-	-	
NC	T6	-	-	-	
NC	T7	-	-	-	
NC	T8	-	-	-	
NC	T9	-	-	-	
NC	T10	-	-	-	
NC	T11	-	-	-	
NC	T13	-	-	-	
NC	T14	-	-	-	
NC	U3	-	-	-	
NC	U4	-	-	-	

Table 4-22. No Connects (continued)

Pin		Signal Type	Default Pull State	Pull Type	Description
Signal Name	337 GWT				
NC	U6	-	-	-	No Connects. These balls are not connected to any internal logic and can be connected to the PCB ground without affecting the functionality of the device. Any other ball marked as "NC" may be internally connected to some functionality. It is recommended for such balls to be left unconnected.
NC	U7	-	-	-	
NC	U8	-	-	-	
NC	U9	-	-	-	
NC	U10	-	-	-	
NC	U11	-	-	-	
NC	V3	-	-	-	
NC	V4	-	-	-	
NC	V11	-	-	-	
NC	V12	-	-	-	
NC	W4	-	-	-	
NC	W11	-	-	-	
NC	W12	-	-	-	
NC	W13	-	-	-	

4.1.1.1.21 Supply for Core Logic: 1.2V nominal**Table 4-23. GWT Supply for Core Logic: 1.2V nominal**

Pin		Signal Type	Default Pull State	Pull Type	Description
Signal Name	337 GWT				
VCC	F9	1.2V Power	-	None	Core supply
VCC	F10				
VCC	H10				
VCC	J14				
VCC	K6				
VCC	K8				
VCC	K12				
VCC	K14				
VCC	L6				
VCC	M10				
VCC	P10				

4.1.1.1.22 Supply for I/O Cells: 3.3V nominal
Table 4-24. GWT Supply for I/O Cells: 3.3V nominal

Pin		Signal Type	Default Pull State	Pull Type	Description
Signal Name	337 GWT				
VCCIO	F6	3.3V Power	-	None	Operating supply for I/Os
VCCIO	F7				
VCCIO	F11				
VCCIO	F12				
VCCIO	F13				
VCCIO	F14				
VCCIO	G6				
VCCIO	G14				
VCCIO	H6				
VCCIO	H14				
VCCIO	J6				
VCCIO	L14				
VCCIO	M6				
VCCIO	M14				
VCCIO	N6				
VCCIO	N14				
VCCIO	P6				
VCCIO	P7				
VCCIO	P8				
VCCIO	P9				
VCCIO	P12				
VCCIO	P13				
VCCIO	P14				

4.1.1.1.23 Ground Reference for All Supplies Except VCCAD

Table 4-25. GWT Ground Reference for All Supplies Except VCCAD

Pin		Signal Type	Default Pull State	Pull Type	Description
Signal Name	337 GWT				
VSS	A1	Ground	-	None	Ground reference
VSS	A2				
VSS	A18				
VSS	A19				
VSS	B1				
VSS	B19				
VSS	H8				
VSS	H9				
VSS	H11				
VSS	H12				
VSS	J8				
VSS	J9				
VSS	J10				
VSS	J11				
VSS	J12				
VSS	K9				
VSS	K10				
VSS	K11				
VSS	L8				
VSS	L9				
VSS	L10				
VSS	L11				
VSS	L12				
VSS	M8				
VSS	M9				
VSS	M11				
VSS	M12				
VSS	V1				
VSS	W1				
VSS	W2				

5 Specifications

5.1 Absolute Maximum Ratings

over operating free-air temperature⁽¹⁾

		MIN	MAX	UNIT
Supply voltage	$V_{CC}^{(2)}$	-0.3	1.43	V
	$V_{CCIO}, V_{CCP}^{(2)}$	-0.3	4.6	
	V_{CCAD}	-0.3	5.5	
Input voltage	All input pins	-0.3	4.6	V
	ADC input pins	-0.3	5.5	
Input clamp current	I_{IK} ($V_I < 0$ or $V_I > V_{CCIO}$) All pins, except AD1IN[23:0] and AD2IN[15:0]	-20	20	mA
	I_{IK} ($V_I < 0$ or $V_I > V_{CCAD}$) AD1IN[23:0] and AD2IN[15:0]	-10	10	
	Total	-40	40	
T_J	Operating junction temperature	-55	150	°C
T_{stg}	Storage temperature	-65	150	°C

- Stresses beyond those listed under *Absolute Maximum Ratings* may cause permanent damage to the device. These are stress ratings only, and functional operation of the device at these or any other conditions beyond those indicated under *Recommended Operating Conditions* is not implied. Exposure to absolute-maximum-rated conditions for extended periods may affect device reliability.
- Maximum-rated conditions for extended periods may affect device reliability. All voltage values are with respect to their associated grounds.

5.2 ESD Ratings

			VALUE	UNIT	
V_{ESD}	Electrostatic discharge	Human Body Model (HBM), per AEC Q100-002 ⁽¹⁾	±2000	V	
		Charged Device Model (CDM), per AEC Q100-011	All pins		±500
			Corner pins		±750

- AEC Q100-002 indicates HBM stressing is done in accordance with the ANSI/ESDA/JEDEC JS-001 specification.

5.3 Power-On Hours (POH)

POH is a function of voltage and temperature. Usage at higher voltages and temperatures will result in a reduction in POH to achieve the same reliability performance.⁽¹⁾⁽²⁾⁽³⁾⁽⁴⁾

NOMINAL CVDD VOLTAGE (V)	JUNCTION TEMPERATURE (T_J)	LIFETIME POH ⁽⁵⁾
1.2	105 °C	100K

- This information is provided solely for your convenience and does not extend or modify the warranty provided under TI's standard terms and conditions for TI semiconductor products.
- To avoid significant degradation, the device power-on hours (POH) must be limited to those specified in this table.
- Logic functions and parameter values are not assured out of the range specified in the recommended operating conditions.
- Notations in this table cannot be deemed a warranty or deemed to extend or modify the warranty under TI's standard terms and conditions for TI semiconductor products.
- POH represent device operation under the specified nominal conditions continuously for the duration of the calculated lifetime.

5.4 Recommended Operating Conditions

over operating free-air temperature range (unless otherwise noted)⁽¹⁾

		MIN	NOM	MAX	UNIT
V_{CC}	Digital logic supply voltage (Core)	1.14	1.2	1.32	V
V_{CCPLL}	PLL supply voltage	1.14	1.2	1.32	V
V_{CCIO}	Digital logic supply voltage (I/O)	3	3.3	3.6	V
V_{CCAD}	MibADC supply voltage	3	3.3/5.0	5.25	V
V_{CCP}	Flash pump supply voltage	3	3.3	3.6	V
V_{SS}	Digital logic supply ground		0		V

- All voltages are with respect to V_{SS} , except V_{CCAD} , which is with respect to V_{SSAD}

Recommended Operating Conditions (continued)

over operating free-air temperature range (unless otherwise noted)⁽¹⁾

		MIN	NOM	MAX	UNIT
V _{SSAD}	MibADC supply ground	-0.1		0.1	V
V _{ADREFHI}	A-to-D high-voltage reference source	V _{SSAD}		V _{CCAD}	V
V _{ADREFLO}	A-to-D low-voltage reference source	V _{SSAD}		V _{CCAD}	V
V _{SLEW}	Maximum positive slew rate for V _{CCIO} , V _{CCAD} and V _{CCP} supplies			1	V/μs
T _A	Operating free-air temperature	-55		125	°C
T _J	Operating junction temperature ⁽²⁾	-55		150	°C

(2) Reliability data is based upon a temperature profile that is equivalent to 100000 power-on hours at 105°C junction temperature. See [Figure 5-1](#) for more details.

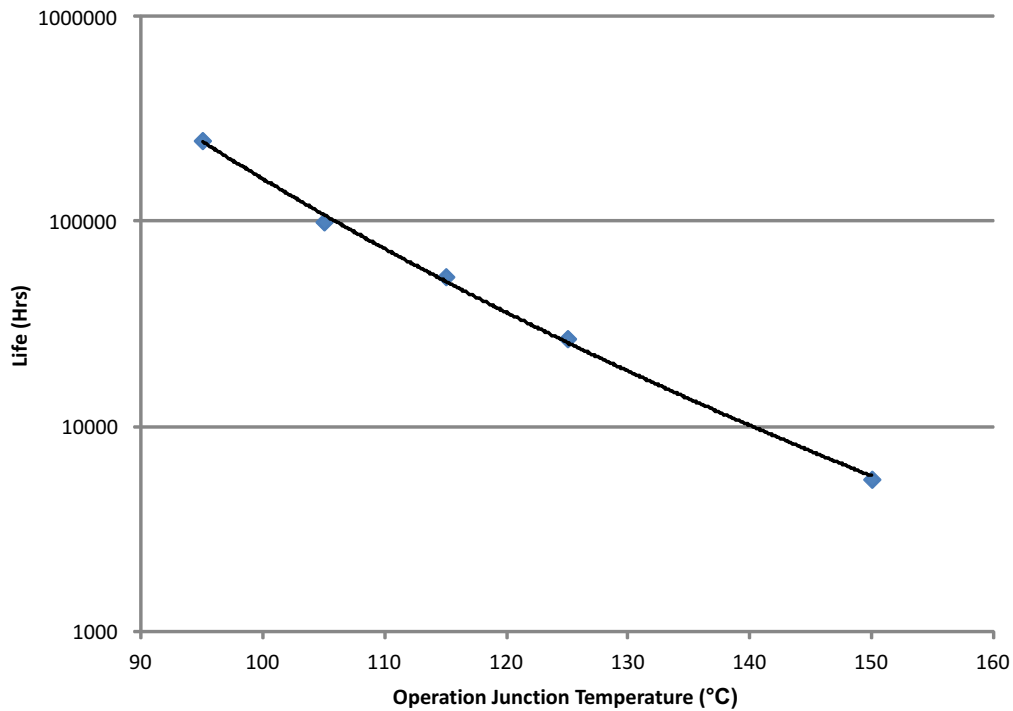

- (1) Silicon operating life design goal is 100000 power-on hours (POH) at 105°C junction temperature (does not include package interconnect life).
- (2) The predicted operating lifetime versus junction temperature is based on reliability modeling using electromigration as the dominant failure mechanism affecting device wearout for the specific device process and design characteristics.

Figure 5-1. TMS570LS3137-EP Operating Life Derating Chart

5.5 Power Consumption

over Recommended Operating Conditions

PARAMETER		TEST CONDITIONS	MIN	TYP	MAX	UNIT
I_{CC}, I_{CCPLL}	V_{CC} Digital supply current (operating mode)	$f_{HCLK} = 180$ MHz $f_{VCLK} = 90$ MHz, Flash in pipelined mode, V_{CCmax}		220 ⁽¹⁾	440 ⁽²⁾	mA
	V_{CC} Digital supply current (LBIST mode)	LBIST clock rate = 90 MHz			700 ⁽³⁾⁽⁴⁾	mA
	V_{CC} Digital supply current (PBIST mode)	PBIST ROM clock frequency = 90 MHz			700 ⁽³⁾⁽⁴⁾	mA
	V_{CC} Digital supply current (operating mode)	$f_{HCLK} = 160$ MHz $f_{VCLK} = 80$ MHz, Flash in pipelined mode, V_{CCmax} (–40°C to 125°C)		200 ⁽¹⁾	420 ⁽²⁾	mA
	V_{CC} Digital supply current (LBIST mode)	LBIST clock rate = 80 MHz (–40°C to 125°C)			665 ⁽³⁾⁽⁴⁾	mA
	V_{CC} Digital supply current (PBIST mode)	PBIST ROM clock frequency = 80 MHz (–40°C to 125°C)			665 ⁽³⁾⁽⁴⁾	mA
I_{CCIO}	V_{CCIO} supply current (operating mode)	No DC load, V_{CCmax}			10	mA
I_{CCAD}	V_{CCAD} supply current (operating mode)	Single ADC operational, $V_{CCADmax}$ (–40°C to 125°C)			15	mA
		Both ADCs operational, $V_{CCADmax}$ (–40°C to 125°C)			30	
$I_{ADREFHI}$	ADREFHI supply current (operating mode)	Single ADC operational, ADREFHI _{max} (–40°C to 125°C)			3	mA
		Both ADCs operational, ADREFHI _{max}			6	
I_{CCP}	V_{CCP} pump supply current	Read from 1 bank and program or erase another bank, V_{CCPmax} (–40°C to 125°C)			60	mA

- (1) The typical value is the average current for the nominal process corner and junction temperature of 25°C.
- (2) The maximum I_{CC} value can be derated
- linearly with voltage
 - by 1 mA/MHz for lower operating frequency when $f_{HCLK} = 2 \times f_{VCLK}$
 - for lower junction temperature by the equation below where T_{JK} is the junction temperature in Kelvin and the result is in milliamperes.

$$235 - 0.15 e^{0.0174 T_{JK}}$$
- (3) The maximum I_{CC} value can be derated
- linearly with voltage
 - by 1.7 mA/MHz for lower operating frequency when $f_{HCLK} = 2 \times f_{VCLK}$
 - for lower junction temperature by the equation below where T_{JK} is the junction temperature in Kelvin and the result is in milliamperes.

$$235 - 0.15 e^{0.0174 T_{JK}}$$
- (4) LBIST and PBIST currents are for a short duration, typically less than 10 ms. They are usually ignored for thermal calculations for the device and the voltage regulator

5.6 Thermal Data

Table 5-1 shows the thermal resistance characteristics for the BGA - GWT mechanical package.

Table 5-1. Thermal Resistance Characteristics (GWT Package)

PARAMETER	°C/W
$R_{\theta JA}$	18.8
$R_{\theta JB}$	14.1
$R_{\theta JC}$	7.1

5.7 Switching Characteristics

over Recommended Operating Conditions for clock domains

Table 5-2. Clock Domain Timing Specifications

PARAMETER	TEST CONDITIONS	MIN	MAX	UNIT
f _{HCLK}	HCLK - System clock frequency	Pipeline mode enabled	180	MHz
		Pipeline mode disabled	50	
f _{GCLK}	GCLK - CPU clock frequency		f _{HCLK}	MHz
f _{VCLK}	VCLK - Primary peripheral clock frequency		100	MHz
f _{VCLK2}	VCLK2 - Secondary peripheral clock frequency		100	MHz
f _{VCLK3}	VCLK3 - Secondary peripheral clock frequency		100	MHz
f _{VCLKA1}	VCLKA1 - Primary asynchronous peripheral clock frequency		100	MHz
f _{VCLKA2}	VCLKA2 - Secondary asynchronous peripheral clock frequency		100	MHz
f _{VCLKA4}	VCLKA4 - Secondary asynchronous peripheral clock frequency		50	MHz
f _{RTICK}	RTICK - clock frequency		f _{VCLK}	MHz

5.8 Wait States Required

RAM

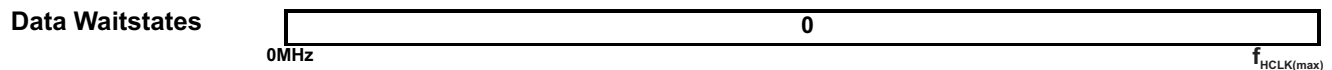
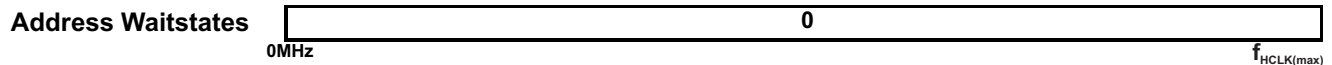

Flash

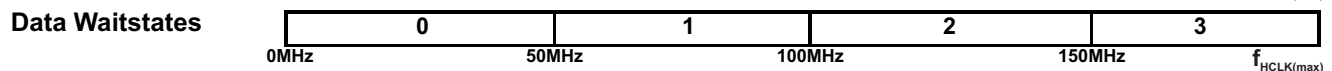
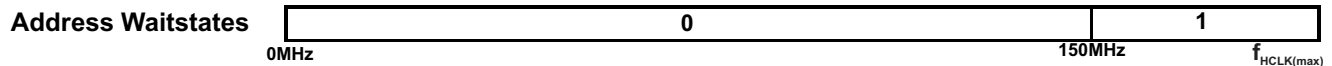

Figure 5-2. Wait States Scheme

As shown in the figure above, the TCM RAM can support program and data fetches at full CPU speed without any address or data wait states required.

The TCM flash can support zero address and data wait states up to a CPU speed of 50 MHz in non-pipelined mode. The flash supports a maximum CPU clock speed of 180MHz for the GWT package, with one address wait state and three data wait states.

The flash wrapper defaults to non-pipelined mode with zero address wait state and one random-read data wait state.

5.9 I/O Electrical Characteristics

 over recommended operating conditions⁽¹⁾

PARAMETER	TEST CONDITIONS	TMS5703137CGWTQEP			TMS5703137CGWTMEP		UNIT
		MIN	TYP	MAX	MIN	MAX	
V_{OL} Low-level output voltage	$I_{OL} = I_{OLmax}$			$0.2 V_{CCIO}$		$0.2 V_{CCIO}$	V
	$I_{OL} = 50 \mu A$, standard output mode			0.2		0.2	
	$I_{OL} = 50 \mu A$, low-EMI output mode (see Section 5.13)			$0.2 V_{CCIO}$		$0.2 V_{CCIO}$	
V_{OH} High-level output voltage	$I_{OH} = I_{OHmax}$	$0.8 V_{CCIO}$			$0.8 V_{CCIO}$		V
	$I_{OH} = 50 \mu A$, standard output mode	$V_{CCIO} - 0.3$			$V_{CCIO} - 0.3$		
	$I_{OH} = 50 \mu A$, low-EMI output mode (see Section 5.13)	$0.8 V_{CCIO}$			$0.8 V_{CCIO}$		
I_{IC} Input clamp current (I/O pins)	$V_I < V_{SSIO} - 0.3$ or $V_I > V_{CCIO} + 0.3$	-3.5		3.5	-3.5	3.5	mA
I_I Input current (I/O pins)	I_{IH} Pulldown 20 μA	$V_I = V_{CCIO}$	5	40		40	μA
	I_{IH} Pulldown 100 μA	$V_I = V_{CCIO}$	40	195	30		
	I_{IL} Pullup 20 μA	$V_I = V_{SS}$	-40	-5	-60	-2	
	I_{IL} Pullup 100 μA	$V_I = V_{SS}$	-195	-40			
	All other pins	No pullup or pulldown	-1	1	-1.5	1.5	
C_I Input capacitance			2				pF
C_O Output capacitance			3				pF

(1) Source currents (out of the device) are negative while sink currents (into the device) are positive.

5.10 Output Buffer Drive Strengths

Table 5-3. Output Buffer Drive Strengths

Low-Level Output Current, I_{OL} for $V_I = V_{OLmax}$ or High-Level Output Current, I_{OH} for $V_I = V_{OHmin}$	Signals
8 mA	FRAYTX2, FRAYTX1, FRAYTXEN1, FRAYTXEN2, MIBSPI5CLK, MIBSPI5SOMI[0], MIBSPI5SOMI[1], MIBSPI5SOMI[2], MIBSPI5SOMI[3], MIBSPI5SIMO[0], MIBSPI5SIMO[1], MIBSPI5SIMO[2], MIBSPI5SIMO[3], TMS, TDI, TDO, RTCK, SPI4CLK, SPI4SIMO, SPI4SOMI, nERROR, N2HET2[1], N2HET2[3], All EMIF Outputs and I/Os, All ETM Outputs
4 mA	MIBSPI3SOMI, MIBSPI3SIMO, MIBSPI3CLK, MIBSPI1SIMO, MIBSPI1SOMI, MIBSPI1CLK, nRST

Table 5-3. Output Buffer Drive Strengths (continued)

Low-Level Output Current, I_{OL} for $V_I = V_{OLmax}$ or High-Level Output Current, I_{OH} for $V_I = V_{OHmin}$	Signals
2 mA zero-dominant	AD1EVT, CAN1RX, CAN1TX, CAN2RX, CAN2TX, CAN3RX, CAN3TX, DMM_CLK, DMM_DATA[0], DMM_DATA[1], DMM_nENA, DMM_SYNC, GIOA[0-7], GIOB[0-7], LINRX, LINTX, MIBSPI1NCS[0], MIBSPI1NCS[1-3], MIBSPI1NENA, MIBSPI3NCS[0-3], MIBSPI3NENA, MIBSPI5NCS[0-3], MIBSPI5NENA, N2HET1[0-31], N2HET2[0], N2HET2[2], N2HET2[4], N2HET2[5], N2HET2[6], N2HET2[7], N2HET2[8], N2HET2[9], N2HET2[10], N2HET2[11], N2HET2[12], N2HET2[13], N2HET2[14], N2HET2[15], N2HET2[16], N2HET2[18], SPI4NCS[0], SPI4NENA
selectable 8 mA / 2 mA	ECLK, SPI2CLK, SPI2SIMO, SPI2SOMI The default output buffer drive strength is 8mA for these signals.

Table 5-4. Selectable 8 mA/2 mA Control

Signal	Control Bit	Address	8 mA	2 mA
ECLK	SYSPC10[0]	0xFFFF FF78	0	1
SPI2CLK	SPI2PC9[9]	0xFFF7 F668	0	1
SPI2SIMO	SPI2PC9[10]	0xFFF7 F668	0	1
SPI2SOMI	SPI2PC9[11]	0xFFF7 F668	0	1

5.11 Input Timings

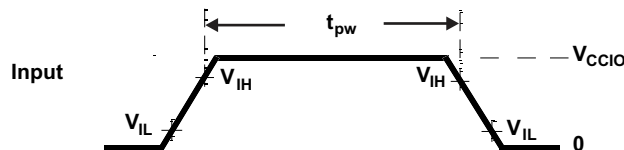

Figure 5-3. TTL-Level Inputs

Table 5-5. Timing Requirements for Inputs⁽¹⁾

			MIN	MAX	UNIT
t_{pw}	Input minimum pulse width	-40°C to 125°C	$t_{c(VCLK)} + 10^{(2)}$		ns

(1) $t_{c(VCLK)}$ = peripheral VBUS clock cycle time = $1 / f_{(VCLK)}$
 (2) The timing shown above is only valid for pin used in GPIO mode.

5.12 Output Timings

Table 5-6. Switching Characteristics for Output Timings versus Load Capacitance (C_L)

 C_L = 15 pF, C_L = 50 pF, C_L = 100 pF T_A = T_J = -40°C to 125°C, but for C_L = 150 pF load T_A = T_J = -55°C to 125°C

PARAMETER			MIN	MAX	UNIT		
Rise time, t _r	8 mA low EMI pins (see Table 5-3)	C _L = 15 pF		2.5	ns		
		C _L = 50 pF		4			
		C _L = 100 pF		7.2			
		C _L = 150 pF		12.5			
Fall time, t _f		C _L = 15 pF		2.5	ns		
		C _L = 50 pF		4			
		C _L = 100 pF		7.2			
		C _L = 150 pF		12.5			
Rise time, t _r	4 mA low EMI pins (see Table 5-3)	C _L = 15 pF		5.6	ns		
		C _L = 50 pF		10.4			
		C _L = 100 pF		16.8			
		C _L = 150 pF		23.2			
Fall time, t _f		C _L = 15 pF		5.6	ns		
		C _L = 50 pF		10.4			
		C _L = 100 pF		16.8			
		C _L = 150 pF		23.2			
Rise time, t _r	2 mA-z low EMI pins (see Table 5-3)	C _L = 15 pF		8	ns		
		C _L = 50 pF		15			
		C _L = 100 pF		23			
		C _L = 150 pF		33			
Fall time, t _f		C _L = 15 pF		8	ns		
		C _L = 50 pF		15			
		C _L = 100 pF		23			
		C _L = 150 pF		33			
Rise time, t _r	Selectable 8 mA / 2 mA-z pins (see Table 5-3)	8mA mode	C _L = 15 pF		2.5	ns	
			C _L = 50 pF		4		
			C _L = 100 pF		7.2		
			C _L = 150 pF		12.5		
Fall time, t _f				C _L = 15 pF		2.5	ns
				C _L = 50 pF		4	
				C _L = 100 pF		7.2	
				C _L = 150 pF		12.5	
Rise time, t _r		2mA-z mode	C _L = 15 pF		8	ns	
			C _L = 50 pF		15		
			C _L = 100 pF		23		
			C _L = 150 pF		33		
Fall time, t _f			C _L = 15 pF		8	ns	
			C _L = 50 pF		15		
			C _L = 100 pF		23		
			C _L = 150 pF		33		

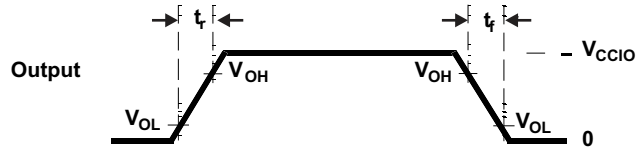

Figure 5-4. CMOS-Level Outputs

Table 5-7. Timing Requirements for Outputs⁽¹⁾

			MIN	MAX	UNIT
$t_{d(\text{parallel_out})}$	Delay between low to high, or high to low transition of general-purpose output signals that can be configured by an application in parallel, for example, all signals in a GIOA port, or all N2HET1 signals, and so forth	-40°C to 125°C		5	ns

(1) This specification does not account for any output buffer drive strength differences or any external capacitive loading differences. Check [Table 5-3](#) for output buffer drive strength information on each signal.

5.13 Low-EMI Output Buffers

The low-EMI output buffer has been designed explicitly to address the issue of decoupling sources of emissions from the pins which they drive. This is accomplished by adaptively controlling the impedance of the output buffer, and is particularly effective with capacitive loads.

This is not the default mode of operation of the low-EMI output buffers and must be enabled by setting the system module GPCR1 register for the desired module or signal, as shown in [Table 5-8](#). The adaptive impedance control circuit monitors the DC bias point of the output signal. The buffer internally generates two reference levels, VREFLOW and VREFHIGH, which are set to approximately 10% and 90% of VCCIO, respectively.

Once the output buffer has driven the output to a low level, if the output voltage is below VREFLOW, then the output buffer's impedance will increase to hi-Z. A high degree of decoupling between the internal ground bus and the output pin will occur with capacitive loads, or any load in which no current is flowing, e.g. the buffer is driving low on a resistive path to ground. Current loads on the buffer which attempt to pull the output voltage above VREFLOW will be opposed by the buffer's output impedance so as to maintain the output voltage at or below VREFLOW.

Conversely, once the output buffer has driven the output to a high level, if the output voltage is above VREFHIGH then the output buffer's impedance will again increase to hi-Z. A high degree of decoupling between internal power bus and output pin will occur with capacitive loads or any loads in which no current is flowing, e.g. buffer is driving high on a resistive path to VCCIO. Current loads on the buffer which attempt to pull the output voltage below VREFHIGH will be opposed by the buffer's output impedance so as to maintain the output voltage at or above VREFHIGH.

The bandwidth of the control circuitry is relatively low, so that the output buffer in adaptive impedance control mode cannot respond to high-frequency noise coupling into the buffer's power buses. In this manner, internal bus noise approaching 20% peak-to-peak of VCCIO can be rejected.

Unlike standard output buffers which clamp to the rails, an output buffer in impedance control mode will allow a positive current load to pull the output voltage up to VCCIO + 0.6V without opposition. Also, a negative current load will pull the output voltage down to VSSIO – 0.6V without opposition. This is not an issue since the actual clamp current capability is always greater than the IOH / IOL specifications.

The low-EMI output buffers are automatically configured to be in the standard buffer mode when the device enters a low-power mode.

Table 5-8. Low-EMI Output Buffer Hookup

Module or Signal Name	Control Register to Enable Low-EMI Mode
Module: MibSPI1	GPREG1.0
	GPREG1.1
Module: MibSPI3	GPREG1.2
Reserved	GPREG1.3
Module: MibSPI5	GPREG1.4
Signal: TMS	GPREG1.8
Signal: TDI	GPREG1.9
Signal: TDO	GPREG1.10
Signal: RTCK	GPREG1.11
Signal: TEST	GPREG1.12
Signal: nERROR	GPREG1.13
Reserved	GPREG1.14

6 System Information and Electrical Specifications

6.1 Device Power Domains

The device core logic is split up into multiple power domains in order to optimize the power for a given application use case. There are 8 core power domains in total: PD1, PD2, PD3, PD4, PD5, RAM_PD1, RAM_PD2, and RAM_PD3.

The actual contents of these power domains are indicated in [Section 1.4](#).

PD1 is an "always-ON" power domain, which cannot be turned off. Each of the other core power domains can be turned ON/OFF one time during device initialization as per the application requirement. Refer to the Power Management Module (PMM) chapter of TMS570LS31X/21X Technical Reference Manual ([SPNU499](#)) for more details.

NOTE

The clocks to a module must be turned off before powering down the core domain that contains the module.

NOTE

The logic in the modules that are powered down lose power completely. Any access to modules that are powered down results in an abort being generated. When power is restored, the modules power-up to their default states (after normal power-up). No register or memory contents are preserved in the core domains that are turned off.

6.2 Voltage Monitor Characteristics

A voltage monitor is implemented on this device. The purpose of this voltage monitor is to eliminate the requirement for a specific sequence when powering up the core and I/O voltage supplies.

6.2.1 Important Considerations

- The voltage monitor does not eliminate the need of a voltage supervisor circuit to ensure that the device is held in reset when the voltage supplies are out of range.
- The voltage monitor only monitors the core supply (VCC) and the I/O supply (VCCIO). The other supplies are not monitored by the VMON. For example, if the VCCAD or VCCP are supplied from a source different from that for VCCIO, then there is no internal voltage monitor for the VCCAD and VCCP supplies.

6.2.2 Voltage Monitor Operation

The voltage monitor generates the Power Good MCU signal (PGMCU) as well as the I/Os Power Good IO signal (PGIO) on the device. During power-up or power-down, the PGMCU and PGIO are driven low when the core or I/O supplies are lower than the specified minimum monitoring thresholds. The PGIO and PGMCU being low isolates the core logic as well as the I/O controls during the power-up or power-down of the supplies. This allows the core and I/O supplies to be powered up or down in any order.

When the voltage monitor detects a low voltage on the I/O supply, it will assert a power-on reset. When the voltage monitor detects an out-of-range voltage on the core supply, it asynchronously makes all output pins high impedance, and asserts a power-on reset. The voltage monitor is disabled when the device enters a low power mode.

The VMON also incorporates a glitch filter for the nPORRST input. Refer to [Section 6.3.3.1](#) for the timing information on this glitch filter.

Table 6-1. Voltage Monitoring Specifications

PARAMETER		MIN	TYP	MAX	UNIT
V _{MON}	VCC low - VCC level below this threshold is detected as too low.	0.75	0.9	1.13	V
	VCC high - VCC level above this threshold is detected as too high.	1.40	1.7	2.1	
	VCCIO low - VCCIO level below this threshold is detected as too low.	1.85	2.4	2.9	

6.2.3 Supply Filtering

The VMON has the capability to filter glitches on the VCC and VCCIO supplies.

The following table shows the characteristics of the supply filtering. Glitches in the supply larger than the maximum specification cannot be filtered.

Table 6-2. VMON Supply Glitch Filtering Capability

PARAMETER	MIN	MAX	UNIT
Width of glitch on VCC that can be filtered	250	1000	ns
Width of glitch on VCCIO that can be filtered	250	1000	

6.3 Power Sequencing and Power On Reset

6.3.1 Power-Up Sequence

There is no timing dependency between the ramp of the VCCIO and the VCC supply voltage. The power-up sequence starts with the I/O voltage rising above the minimum I/O supply threshold, (see [Table 6-4](#) for more details), core voltage rising above the minimum core supply threshold and the release of power-on reset. The high frequency oscillator will start up first and its amplitude will grow to an acceptable level. The oscillator start up time is dependent on the type of oscillator and is provided by the oscillator vendor. The different supplies to the device can be powered up in any order.

The device goes through the following sequential phases during power up.

Table 6-3. Power-Up Phases

Phases	Oscillator Cycles
Oscillator start-up and validity check	1032 oscillator cycles
eFuse autoloading	1180 oscillator cycles
Flash pump power-up	688 oscillator cycles
Flash bank power-up	617 oscillator cycles
Total	3517 oscillator cycles

The CPU reset is released at the end of the above sequence and fetches the first instruction from address 0x00000000.

6.3.2 Power-Down Sequence

The different supplies to the device can be powered down in any order.

6.3.3 Power-On Reset: nPORRST

This is the power-on reset. This reset must be asserted by an external circuitry whenever the I/O or core supplies are outside the specified recommended range. This signal has a glitch filter on it. It also has an internal pulldown.

6.3.3.1 nPORRST Electrical and Timing Requirements

Table 6-4. Electrical Requirements for nPORRST

NO.	PARAMETER	TEST CONDITIONS	MIN	MAX	UNIT	
	V_{CCPORL}	V_{CC} low supply level when nPORRST must be active during power-up	-40°C to 125°C	0.5	V	
	V_{CCPORH}	V_{CC} high supply level when nPORRST must remain active during power-up and become active during power down	-40°C to 125°C	1.14	V	
	$V_{CCIOPORL}$	V_{CCIO} / V_{CCP} low supply level when nPORRST must be active during power-up	-40°C to 125°C	1.1	V	
	$V_{CCIOPORH}$	V_{CCIO} / V_{CCP} high supply level when nPORRST must remain active during power-up and become active during power down	-40°C to 125°C	3.0	V	
	$V_{IL(PORRST)}$	Low-level input voltage of nPORRST $V_{CCIO} > 2.5$ V	-40°C to 125°C	$0.2 \times V_{CCIO}$	V	
		Low-level input voltage of nPORRST $V_{CCIO} < 2.5$ V	-40°C to 125°C	0.5	V	
3	$t_{su(PORRST)}$	Setup time, nPORRST active before V_{CCIO} and $V_{CCP} > V_{CCIOPORL}$ during power-up	-40°C to 125°C	0	ms	
6	$t_h(PORRST)$	Hold time, nPORRST active after $V_{CC} > V_{CCPORH}$	-40°C to 125°C	1	ms	
7	$t_{su(PORRST)}$	Setup time, nPORRST active before $V_{CC} < V_{CCPORH}$ during power down	-40°C to 125°C	2	μs	
8	$t_h(PORRST)$	Hold time, nPORRST active after V_{CCIO} and $V_{CCP} > V_{CCIOPORH}$	-40°C to 125°C	1	ms	
9	$t_h(PORRST)$	Hold time, nPORRST active after $V_{CC} < V_{CCPORL}$	-40°C to 125°C	0	ms	
	$t_f(nPORRST)$	Filter time nPORRST pin; Pulses less than MIN will be filtered out, pulses greater than MAX will generate a reset.		500	2000	ns

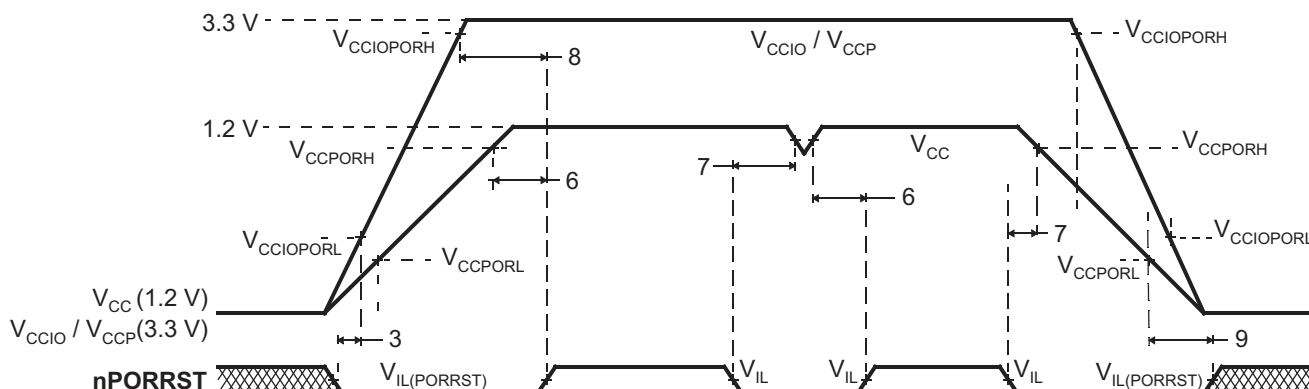

NOTE: There is no timing dependency between the ramp of the VCCIO and the VCC supply voltage; this is just an exemplary drawing.

Figure 6-1. nPORRST Timing Diagram

6.4 Warm Reset (nRST)

This is a bidirectional reset signal. The internal circuitry drives the signal low on detecting any device reset condition. An external circuit can assert a device reset by forcing the signal low. On this terminal, the output buffer is implemented as an open drain (drives low only). To ensure an external reset is not arbitrarily generated, TI recommends that an external pullup resistor is connected to this terminal.

This terminal has a glitch filter. It also has an internal pullup

6.4.1 Causes of Warm Reset

Table 6-5. Causes of Warm Reset

DEVICE EVENT	SYSTEM STATUS FLAG
Power-Up Reset	Exception Status Register, bit 15
Oscillator fail	Global Status Register, bit 0
PLL slip	Global Status Register, bits 8 and 9
Watchdog exception / Debugger reset	Exception Status Register, bit 13
CPU Reset (driven by the CPU STC)	Exception Status Register, bit 5
Software Reset	Exception Status Register, bit 4
External Reset	Exception Status Register, bit 3

6.4.2 nRST Timing Requirements

Table 6-6. nRST Timing Requirements⁽¹⁾

			MIN	MAX	UNIT
$t_{v(RST)}$	Valid time, nRST active after nPORRST inactive	–40°C to 125°C	$2252 \times t_{c(OSC)}$		ns
	Valid time, nRST active (all other system reset conditions)	–40°C to 125°C	$32 \times t_{c(VCLK)}$		
$t_{f(nRST)}$	Filter time nRST pin; Pulses less than MIN will be filtered out, pulses greater than MAX will generate a reset		475	2000	ns

(1) Specified values do NOT include rise/fall times. For rise and fall timings, see [Table 5-6](#).

6.5 ARM® Cortex™-R4F CPU Information

6.5.1 Summary of ARM Cortex-R4F CPU Features

The features of the ARM Cortex-R4F CPU include:

- An integer unit with integral EmbeddedICE-RT logic
- High-speed Advanced Microprocessor Bus Architecture (AMBA) Advanced eXtensible Interfaces (AXI) for Level two (L2) master and slave interfaces
- Floating Point Coprocessor
- Dynamic branch prediction with a global history buffer, and a 4-entry return stack
- Low interrupt latency
- Non-maskable interrupt
- A Harvard Level one (L1) memory system with:
 - Tightly-Coupled Memory (TCM) interfaces with support for error correction or parity checking memories
 - ARMv7-R architecture Memory Protection Unit (MPU) with 12 regions
- Dual core logic for fault detection in safety-critical applications
- An L2 memory interface:
 - Single 64-bit master AXI interface
 - 64-bit slave AXI interface to TCM RAM blocks
- A debug interface to a CoreSight Debug Access Port (DAP)
- A trace interface to a CoreSight ETM-R4
- A Performance Monitoring Unit (PMU)
- A Vectored Interrupt Controller (VIC) port

For more information on the ARM Cortex-R4F CPU, see www.arm.com.

6.5.2 ARM Cortex-R4F CPU Features Enabled by Software

The following CPU features are disabled on reset and must be enabled by the application if required.

- ECC On Tightly-Coupled Memory (TCM) Accesses
- Hardware Vectored Interrupt (VIC) Port
- Floating Point Coprocessor
- Memory Protection Unit (MPU)

6.5.3 Dual Core Implementation

The device has two Cortex-R4F cores, where the output signals of both CPUs are compared in the CCM-R4 unit. To avoid common mode impacts the signals of the CPUs to be compared are delayed by 2 clock cycles as shown in [Figure 6-3](#).

The CPUs have a diverse CPU placement given by following requirements:

- Different orientation; for example, CPU1 = "north" orientation, CPU2 = "flip west" orientation
- Dedicated guard ring for each CPU



Figure 6-2. Dual - CPU Orientation

6.5.4 Duplicate Clock Tree After GCLK

The CPU clock domain is split into two clock trees, one for each CPU, with the clock of the 2nd CPU running at the same frequency and in phase to the clock of CPU1. See [Figure 6-3](#).

6.5.5 ARM Cortex-R4F CPU Compare Module (CCM-R4) for Safety

This device has two ARM Cortex-R4F CPU cores, where the output signals of both CPUs are compared in the CCM-R4 unit. To avoid common mode impacts the signals of the CPUs to be compared are delayed in a different way as shown in the figure below.

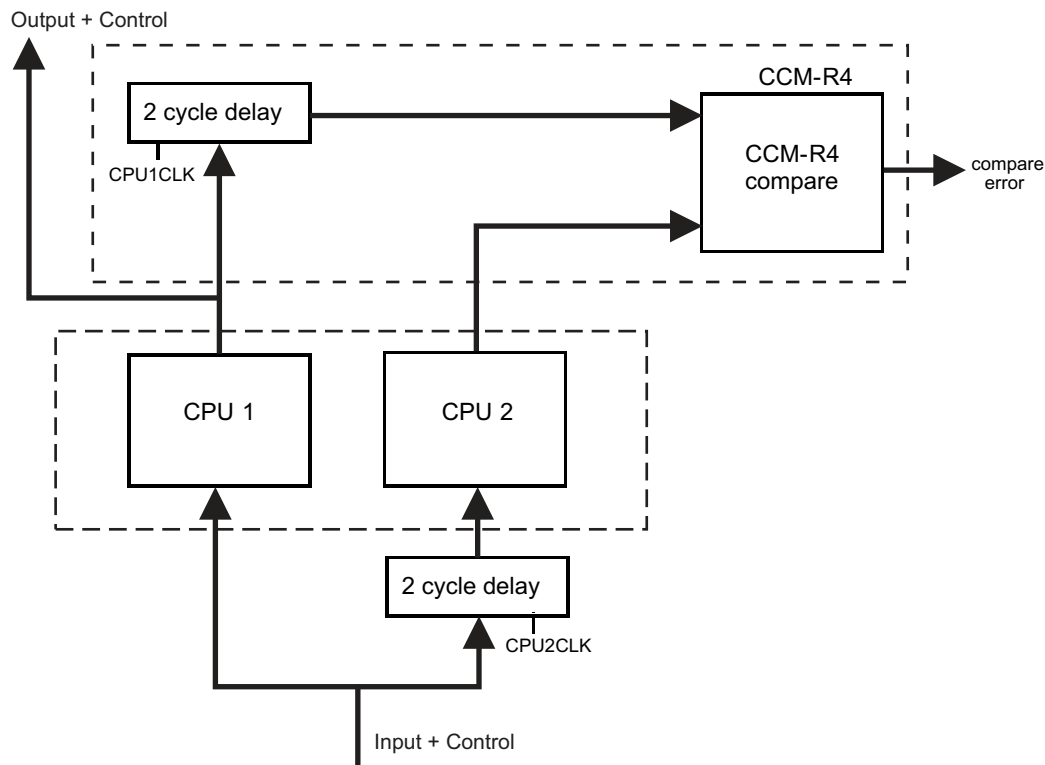

Figure 6-3. Dual Core Implementation

To avoid an erroneous CCM-R4 compare error, the application software must initialize the registers of both CPUs before the registers are used, including function calls where the register values are pushed onto the stack.

6.5.6 CPU Self-Test

The CPU STC (Self-Test Controller) is used to test the two Cortex-R4F CPU Cores using the Deterministic Logic BIST Controller as the test engine.

The main features of the self-test controller are:

- Ability to divide the complete test run into independent test intervals
- Capable of running the complete test as well as running few intervals at a time
- Ability to continue from the last executed interval (test set) as well as ability to restart from the beginning (First test set)
- Complete isolation of the self-tested CPU core from rest of the system during the self-test run
- Ability to capture the Failure interval number
- Timeout counter for the CPU self-test run as a fail-safe feature

6.5.6.1 Application Sequence for CPU Self-Test

1. Configure clock domain frequencies.
2. Select number of test intervals to be run.
3. Configure the timeout period for the self-test run.
4. Enable self-test.
5. Wait for CPU reset.
6. In the reset handler, read CPU self-test status to identify any failures.
7. Retrieve CPU state if required.

For more information see the device specific technical reference manual.

6.5.6.2 CPU Self-Test Clock Configuration

The maximum clock rate for the self-test is 90MHz. The STCCLK is divided down from the CPU clock. This divider is configured by the STCCLKDIV register at address 0xFFFFE108.

For more information see the device specific technical reference manual.

6.5.6.3 CPU Self-Test Coverage

[Table 6-7](#) shows CPU test coverage achieved for each self-test interval. It also lists the cumulative test cycles. The test time can be calculated by multiplying the number of test cycles with the STC clock period.

Table 6-7. CPU Self-Test Coverage

INTERVALS	TEST COVERAGE (%)	TEST CYCLES
0	0	0
1	62.13	1365
2	70.09	2730
3	74.49	4095
4	77.28	5460
5	79.28	6825
6	80.90	8190
7	82.02	9555
8	83.10	10920
9	84.08	12285
10	84.87	13650
11	85.59	15015
12	86.11	16380
13	86.67	17745
14	87.16	19110
15	87.61	20475
16	87.98	21840
17	88.38	23205
18	88.69	24570
19	88.98	25935
20	89.28	27300
21	89.50	28665
22	89.76	30030
23	90.01	31395
24	90.21	32760

6.6 Clocks

6.6.1 Clock Sources

The table below lists the available clock sources on the device. Each of the clock sources can be enabled or disabled using the CSDISx registers in the system module. The clock source number in the table corresponds to the control bit in the CSDISx register for that clock source.

The table also shows the default state of each clock source.

Table 6-8. Available Clock Sources

Clock Source Number	Name	Description	Default State
0	OSCIN	Main oscillator	Enabled
1	PLL1	Output from PLL1	Disabled
2	Reserved	Reserved	Disabled
3	EXTCLKIN1	External clock input 1	Disabled
4	CLK80K	Low frequency output of internal reference oscillator	Enabled
5	CLK10M	High frequency output of internal reference oscillator	Enabled
6	PLL2	Output from PLL2	Disabled
7	EXTCLKIN2	External clock input 2	Disabled
7	Reserved	Reserved	Disabled

6.6.1.1 Main Oscillator

The oscillator is enabled by connecting the appropriate fundamental resonator/crystal and load capacitors across the external OSCIN and OSCOUT pins as shown in [Figure 6-4](#). The oscillator is a single stage inverter held in bias by an integrated bias resistor. This resistor is disabled during leakage test measurement and low power modes.

TI strongly encourages each customer to submit samples of the device to the resonator/crystal vendors for validation. The vendors are equipped to determine what load capacitors will best tune their resonator/crystal to the microcontroller device for optimum start-up and operation over temperature/voltage extremes.

An external oscillator source can be used by connecting a 3.3V clock signal to the OSCIN pin and leaving the OSCOUT pin unconnected (open) as shown in the figure below.

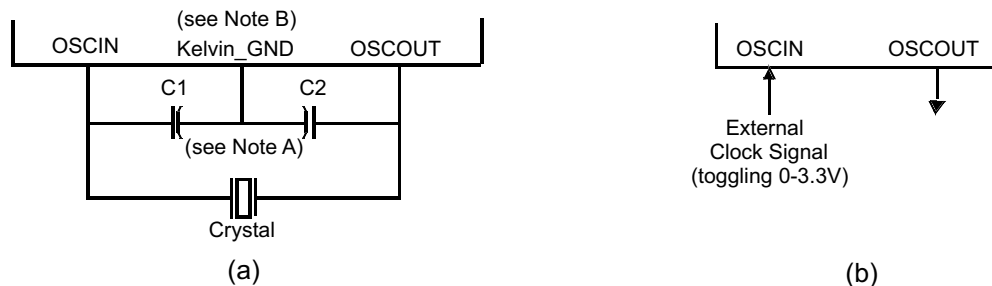

Note A: The values of C1 and C2 should be provided by the resonator/crystal vendor.

Note B: Kelvin_GND should not be connected to any other GND.

Figure 6-4. Recommended Crystal/Clock Connection

6.6.1.1.1 Timing Requirements for Main Oscillator

Table 6-9. Timing Requirements for Main Oscillator

			MIN	MAX	UNIT
$t_{c(OSC)}$	Cycle time, OSCIN (when using a sine-wave input)		50	200	ns
$t_{c(OSC_SQR)}$	Cycle time, OSCIN, (when input to the OSCIN is a square wave)		50	200	ns
$t_{w(OSCIL)}$	Pulse duration, OSCIN low (when input to the OSCIN is a square wave)	–40°C to 125°C	6		ns
$t_{w(OSCIH)}$	Pulse duration, OSCIN high (when input to the OSCIN is a square wave)	–40°C to 125°C	6		ns

6.6.1.2 Low Power Oscillator (LPO)

The LPO is comprised of two oscillators — HF LPO and LF LPO, in a single macro.

6.6.1.2.1 Features

The main features of the LPO are:

- Supplies a clock at extremely low power for power-saving modes. This is connected as clock source # 4 of the Global Clock Module.
- Supplies a high-frequency clock for non-timing-critical systems. This is connected as clock source # 5 of the Global Clock Module.
- Provides a comparison clock for the crystal oscillator failure detection circuit.

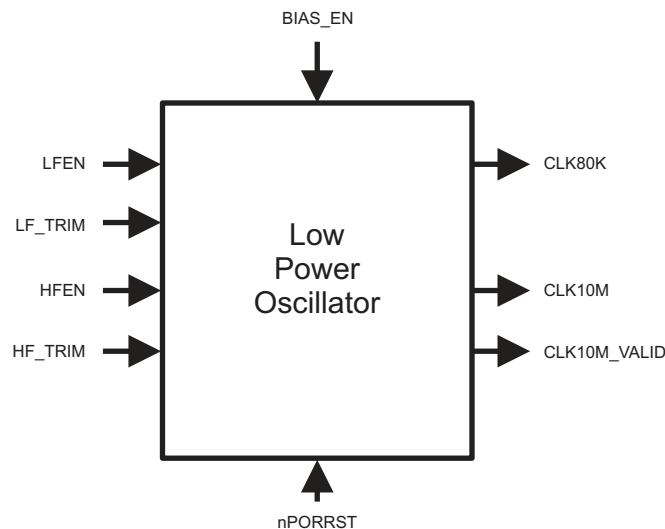

Figure 6-5. LPO Block Diagram

Figure 6-5 shows a block diagram of the internal reference oscillator. This is a low power oscillator (LPO) and provides two clock sources: one nominally 80KHz and one nominally 10MHz.

6.6.1.2.2 LPO Electrical and Timing Specifications

Table 6-10. LPO Specifications

		MIN	NOM	MAX	UNIT
LPO - HF oscillator	Untrimmed frequency	5.5	9.6	19.5	MHz
	Startup time from STANDBY (LPO BIAS_EN High for at least 900 μ s)			10	μ s
	Cold startup time			900	μ s
LPO - LF oscillator	Untrimmed frequency	36	85	180	kHz
	Startup time from STANDBY (LPO BIAS_EN High for at least 900 μ s)			100	μ s
	Cold startup time			2000	μ s

6.6.1.3 Phase Locked Loop (PLL) Clock Modules

The PLL is used to multiply the input frequency to some higher frequency.

The main features of the PLL are:

- Frequency modulation can be optionally superimposed on the synthesized frequency of PLL1. The frequency modulation capability of PLL2 is permanently disabled.
- Configurable frequency multipliers and dividers.
- Built-in PLL Slip monitoring circuit.
- Option to reset the device on a PLL slip detection.

6.6.1.3.1 Block Diagram

The Figure 6-6 shows a high-level block diagram of the two PLL macros on this microcontroller. PLLCTL1 and PLLCTL2 are used to configure the multiplier and dividers for the PLL1. PLLCTL3 is used to configure the multiplier and dividers for PLL2.

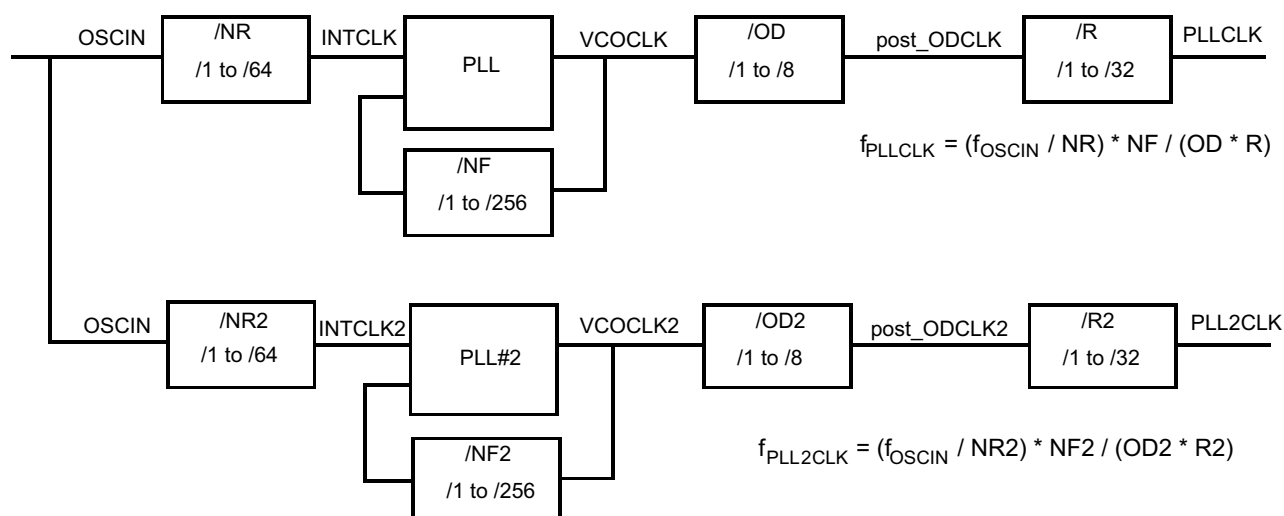

Figure 6-6. GWT PLLx Block Diagram

6.6.1.3.2 PLL Timing Specifications

Table 6-11. PLL Timing Specifications

		MIN	MAX	UNIT
f _{INTCLK}	PLL1 reference clock frequency	1	20	MHz
f _{post_ODCLK}	Post-ODCLK – PLL1 post-divider input clock frequency		400	MHz
f _{VCOCLK}	VCOCLK – PLL1 output divider (OD) input clock frequency	150	550	MHz
f _{INTCLK2}	PLL2 reference clock frequency	1	20	MHz
f _{post_ODCLK2}	Post-ODCLK – PLL2 post-divider input clock frequency		400	MHz
f _{VCOCLK2}	VCOCLK – PLL2 output divider (OD) input clock frequency	150	550	MHz

6.6.1.4 External Clock Inputs

The device supports up to two external clock inputs. This clock input must be a square wave input. The electrical and timing requirements for these clock inputs are specified below. The external clock sources are not checked for validity. They are assumed valid when enabled.

Table 6-12. External Clock Timing and Electrical Specifications

PARAMETER	TEST CONDITIONS	MIN	MAX	UNIT	
$f_{EXTCLKx}$	External clock input frequency		80	MHz	
$t_{w(EXTCLKIN)H}$	EXTCLK high-pulse duration		6	ns	
$t_{w(EXTCLKIN)L}$	EXTCLK low-pulse duration		6	ns	
$V_{IL(EXTCLKIN)}$	Low-level input voltage		–0.3	0.8	V
$V_{IH(EXTCLKIN)}$	High-level input voltage		2	VCCIO + 0.3	V

6.6.2 Clock Domains

6.6.2.1 Clock Domain Descriptions

Table 6-13 lists the device clock domains and their default clock sources. The table also shows the system module control register that is used to select an available clock source for each clock domain.

Table 6-13. Clock Domain Descriptions

Clock Domain Name	Default Clock Source	Clock Source Selection Register	Description
HCLK	OSCIN	GHVSR	<ul style="list-style-type: none"> Is disabled via the CDDISx registers bit 1 Used for all system modules including DMA, ESM
GCLK	OSCIN	GHVSR	<ul style="list-style-type: none"> Always the same frequency as HCLK In phase with HCLK Is disabled separately from HCLK via the CDDISx registers bit 0 Can be divided by 1 up to 8 when running CPU self-test (LBIST) using the CLKDIV field of the STCCCLKDIV register at address 0xFFFFE108
GCLK2	OSCIN	GHVSR	<ul style="list-style-type: none"> Always the same frequency as GCLK 2 cycles delayed from GCLK Is disabled along with GCLK Gets divided by the same divider setting as that for GCLK when running CPU self-test (LBIST)
VCLK	OSCIN	GHVSR	<ul style="list-style-type: none"> Divided down from HCLK Can be HCLK/1, HCLK/2, ... or HCLK/16 Is disabled separately from HCLK via the CDDISx registers bit 2
VCLK2	OSCIN	GHVSR	<ul style="list-style-type: none"> Divided down from HCLK Can be HCLK/1, HCLK/2, ... or HCLK/16 Frequency must be an integer multiple of VCLK frequency Is disabled separately from HCLK via the CDDISx registers bit 3
VCLK3	OSCIN	GHVSR	<ul style="list-style-type: none"> Divided down from HCLK Can be HCLK/1, HCLK/2, ... or HCLK/16 Is disabled separately from HCLK via the CDDISx registers bit 8
VCLKA1	VCLK	VCLKASRC	<ul style="list-style-type: none"> Defaults to VCLK as the source Is disabled via the CDDISx registers bit 4
VCLKA2	VCLK	VCLKASRC	<ul style="list-style-type: none"> Defaults to VCLK as the source Is disabled via the CDDISx registers bit 5

Table 6-13. Clock Domain Descriptions (continued)

Clock Domain Name	Default Clock Source	Clock Source Selection Register	Description
VCLKA3_S	VCLK	VCLKACON	<ul style="list-style-type: none"> Defaults to VCLK as the source Frequency can be as fast as HCLK frequency. Is disabled via the CDDISx registers bit 10
VCLKA3_DIVR	VCLK	VCLKACON1	<ul style="list-style-type: none"> Divided down from the VCLKA3_S using the VCLKA3R field of the VCLKACON1 register at address 0xFFFFE140 Frequency can be VCLKA3_S/1, VCLKA3_S/2, ..., or VCLKA3_S/8 Default frequency is VCLKA3_S/2 Is disabled separately via the VCLKACON1 register VCLKA3_DIV_CDDIS bit only if the VCLKA3_S clock is not disabled
VCLKA4	VCLK	VCLKACON1	<ul style="list-style-type: none"> Defaults to VCLK as the source Is disabled via the CDDISx registers bit 11
RTICK	VCLK	RCLKSRC	<ul style="list-style-type: none"> Defaults to VCLK as the source If a clock source other than VCLK is selected for RTICK, then the RTICK frequency must be less than or equal to VCLK/3 <ul style="list-style-type: none"> Application can ensure this by programming the RTI1DIV field of the RCLKSRC register, if necessary Is disabled via the CDDISx registers bit 6

6.6.2.2 Mapping of Clock Domains to Device Modules

Each clock domain has a dedicated functionality as shown in the figures below.

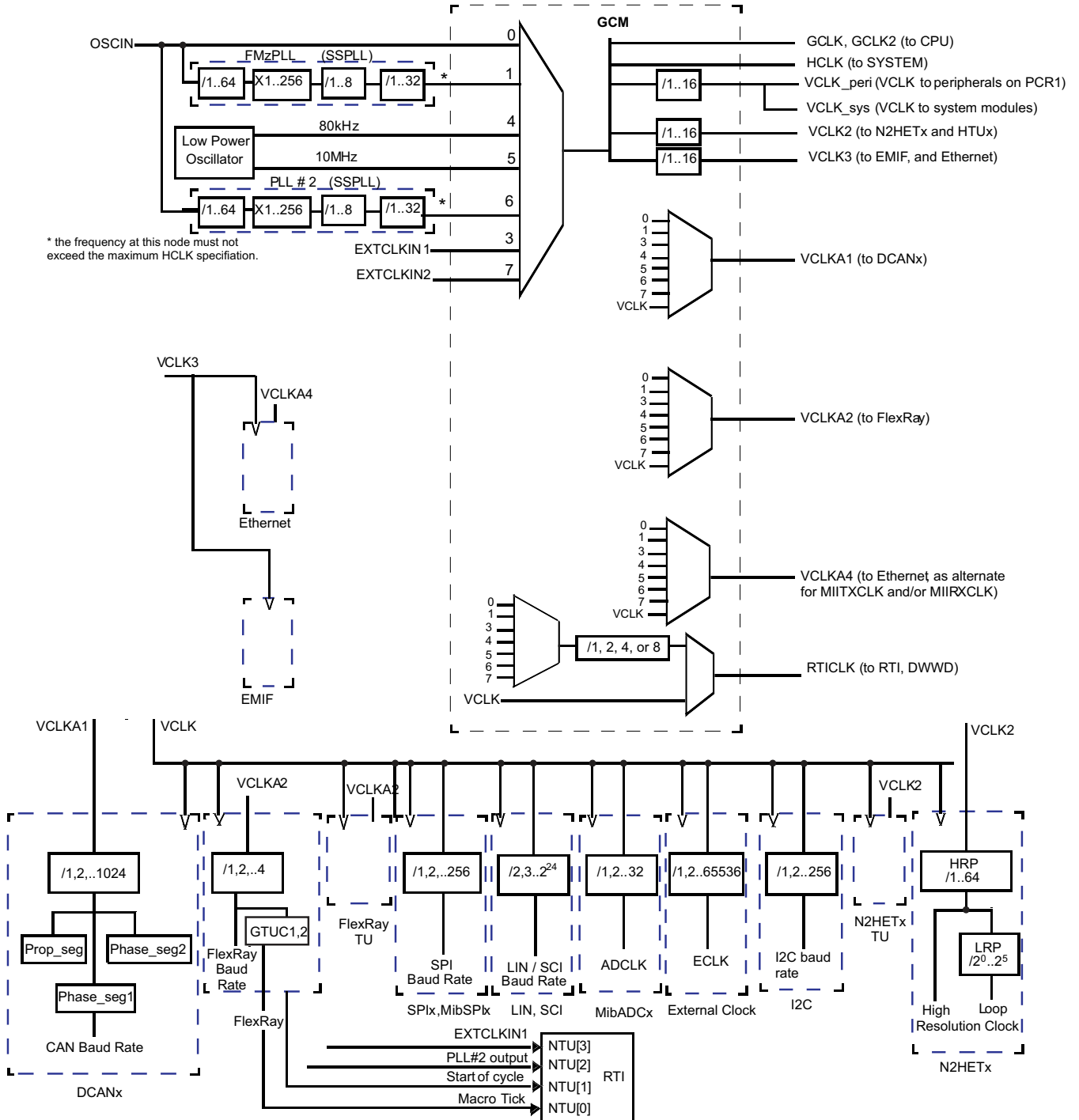

Figure 6-7. Device Clock Domains

6.6.3 Clock Test Mode

The TMS570 platform architecture defines a special mode that allows various clock signals to be brought out on to the ECLK pin and N2HET1[12] device outputs. This mode is called the Clock Test mode. It is very useful for debugging purposes and can be configured via the CLKTEST register in the system module.

Table 6-14. Clock Test Mode Options

SEL_ECP_PIN = CLKTEST[3-0]	SIGNAL ON ECLK	SEL_GIO_PIN = CLKTEST[11-8]	SIGNAL ON N2HET1[12]
0000	Oscillator	0000	Oscillator Valid Status
0001	Main PLL free-running clock output	0001	Main PLL Valid status
0010	Reserved	0010	Reserved
0011	EXTCLKIN1	0011	Reserved
0100	CLK80K	0100	Reserved
0101	CLK10M	0101	CLK10M Valid status
0110	Secondary PLL free-running clock output	0110	Secondary PLL Valid Status
0111		0111	Reserved
1000	GCLK	1000	CLK80K
1001	RTI Base	1001	Reserved
1010	Reserved	1010	Reserved
1011	VCLKA1	1011	Reserved
1100	VCLKA2	1100	Reserved
1101	Reserved	1101	Reserved
1110	VCLKA4	1110	Reserved
1111	Reserved	1111	Reserved

6.7 Clock Monitoring

The LPO Clock Detect (LPOCLKDET) module consists of a clock monitor (CLKDET) and an internal low power oscillator (LPO).

The LPO provides two different clock sources – a low frequency (CLK80K) and a high frequency (CLK10M).

The CLKDET is a supervisor circuit for an externally supplied clock signal (OSCIN). In case the OSCIN frequency falls out of a frequency window, the CLKDET flags this condition in the global status register (GLBSTAT bit 0: OSC FAIL) and switches all clock domains sourced by OSCIN to the CLK10M clock (limp mode clock).

The valid OSCIN frequency range is defined as: $f_{\text{CLK10M}} / 4 < f_{\text{OSCIN}} < f_{\text{CLK10M}} * 4$.

6.7.1 Clock Monitor Timings

Table 6-15. LPO and Clock Detection

PARAMETER		TEST CONDITIONS	MIN	NOM	MAX	UNIT
Clock Detection	oscillator fail frequency - lower threshold, using untrimmed LPO output		1.375	2.4	4.875	MHz
	oscillator fail frequency - higher threshold, using untrimmed LPO output		22	38.4	78	MHz
LPO - HF oscillator	untrimmed frequency		5.5	9.6	19.5	MHz
	startup time from STANDBY (LPO BIAS_EN High for at least 900ms)				10	μs
	cold startup time				900	μs
	ICC, CLK10M and CLK80K active	–40°C to 125°C			150	μA
LPO - LF oscillator	untrimmed frequency		36	85	180	kHz
	startup time from STANDBY (LPO BIAS_EN High for at least 900ms)				100	μs
	cold startup time				2000	μs
	ICC, only CLK80K active	–40°C to 125°C			27	μA
LPO	total ICC STANDBY current	–40°C to 125°C			20	μA

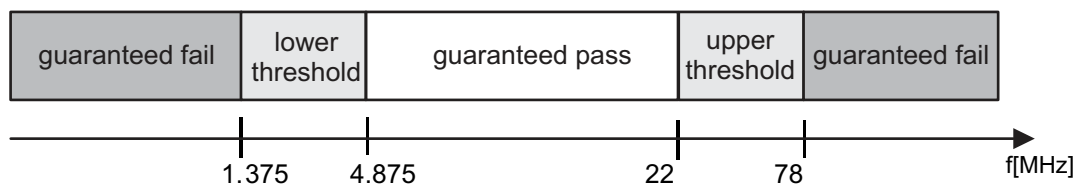

Figure 6-8. LPO and Clock Detection, Untrimmed CLK10M

6.7.2 External Clock (ECLK) Output Functionality

The ECLK pin can be configured to output a pre-scaled clock signal indicative of an internal device clock. This output can be externally monitored as a safety diagnostic.

6.7.3 Dual Clock Comparators

The Dual Clock Comparator (DCC) module determines the accuracy of selectable clock sources by counting the pulses of two independent clock sources (counter 0 and counter 1). If one clock is out of spec, an error signal is generated. For example, the DCC1 can be configured to use CLK10M as the reference clock (for counter 0) and VCLK as the "clock under test" (for counter 1). This configuration allows the DCC1 to monitor the PLL output clock when VCLK is using the PLL output as its source.

An additional use of this module is to measure the frequency of a selectable clock source, using the input clock as a reference, by counting the pulses of two independent clock sources. Counter 0 generates a fixed-width counting window after a preprogrammed number of pulses. Counter 1 generates a fixed-width pulse (1 cycle) after a pre-programmed number of pulses. This pulse sets as an error signal if counter 1 does not reach 0 within the counting window generated by counter 0.

6.7.3.1 Features

- Takes two different clock sources as input to two independent counter blocks.
- One of the clock sources is the known-good, or reference clock; the second clock source is the "clock under test."
- Each counter block is programmable with initial, or seed values.
- The counter blocks start counting down from their seed values at the same time; a mismatch from the expected frequency for the clock under test generates an error signal which is used to interrupt the CPU.

6.7.3.2 Mapping of DCC Clock Source Inputs

Table 6-16. DCC1 Counter 0 Clock Sources

CLOCK SOURCE [3:0]	CLOCK NAME
others	oscillator (OSCIN)
0x5	high frequency LPO
0xA	test clock (TCK)

Table 6-17. DCC1 Counter 1 Clock Sources

KEY [3:0]	CLOCK SOURCE [3:0]	CLOCK NAME
others	—	N2HET1[31]
0xA	0x0	Main PLL free-running clock output
	0x1	
	0x2	low frequency LPO
	0x3	high frequency LPO
	0x4	flash HD pump oscillator
	0x5	EXTCLKIN1
	0x6	
	0x7	ring oscillator
	0x8 - 0xF	VCLK

Table 6-18. DCC2 Counter 0 Clock Sources

CLOCK SOURCE [3:0]	CLOCK NAME
others	oscillator (OSCIN)
0xA	test clock (TCK)

Table 6-19. DCC2 Counter 1 Clock Sources

KEY [3:0]	CLOCK SOURCE [3:0]	CLOCK NAME
others	—	N2HET2[0]
0xA	00x0 - 0x7	Reserved
	0x8 - 0xF	VCLK

6.8 Glitch Filters

A glitch filter is present on the following signals.

Table 6-20. Glitch Filter Timing Specifications

PIN	PARAMETER	TMS5703137CGWTQEP			TMS5703137CGWTMEP		UNIT
		MIN	TYP	MAX	MIN	MAX	
tf(nPORRST)	Filter time nPORRST pin; pulses less than MIN will be filtered out, pulses greater than MAX will generate a reset ⁽¹⁾	500		2000	475	2000	ns
tf(nRST)	Filter time nRST pin; pulses less than MIN will be filtered out, pulses greater than MAX will generate a reset	475		2000	450	2000	ns
tf(TEST)	Filter time TEST pin; pulses less than MIN will be filtered out, pulses greater than MAX will pass through	500		2000	475	2000	ns

- (1) The glitch filter design on the nPORRST signal is designed such that no size pulse will reset any part of the microcontroller (flash pump, I/O pins, etc.) without also generating a valid reset signal to the CPU.

6.9 Device Memory Map

6.9.1 Memory Map Diagram

The figure below shows the device memory map.

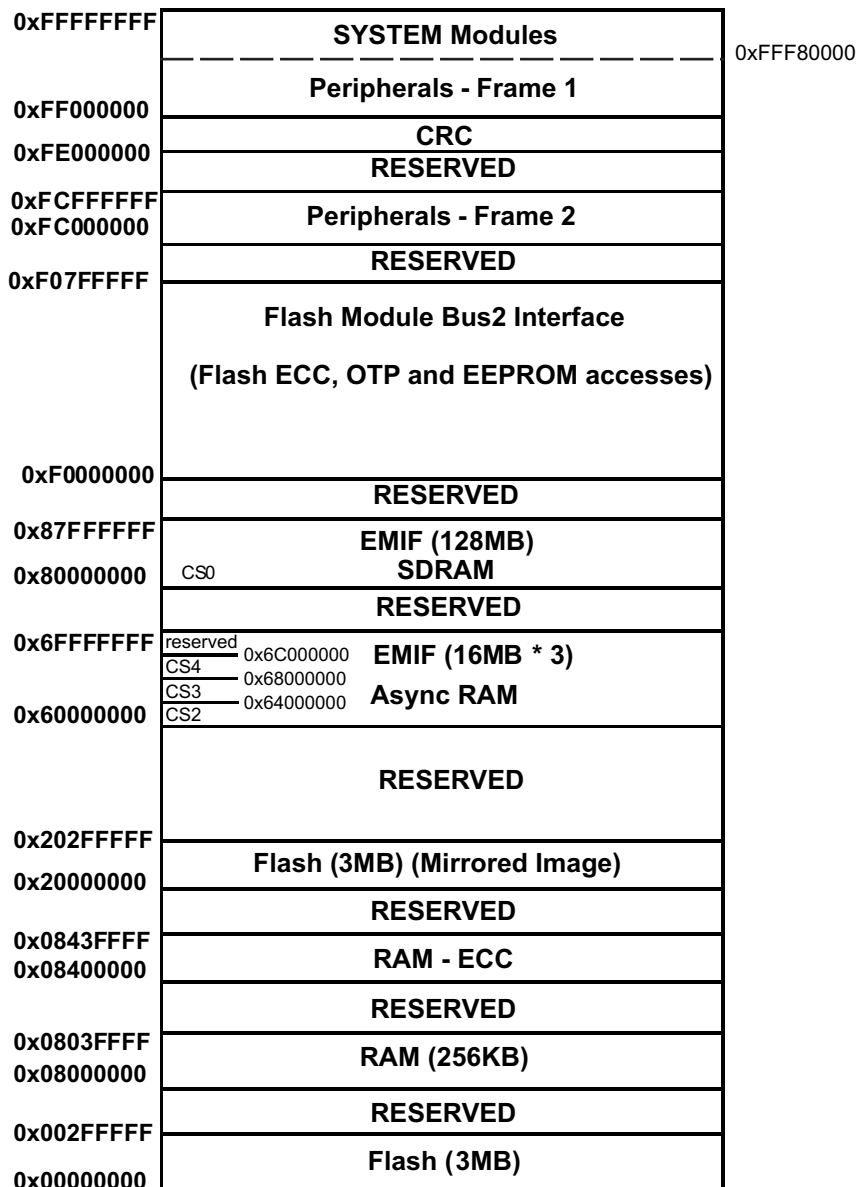

Figure 6-9. Memory Map

The Flash memory is mirrored to support ECC logic testing. The base address of the mirrored Flash image is 0x2000 0000.

6.9.2 Memory Map Table

Table 6-21. Device Memory Map

MODULE NAME	FRAME CHIP SELECT	FRAME ADDRESS RANGE		FRAME SIZE	ACTUAL SIZE	RESPONSE FOR ACCESS TO UNIMPLEMENTED LOCATIONS IN FRAME
		START	END			
Memories Tightly Coupled to the ARM Cortex-R4F CPU						
TCM Flash	CS0	0x0000_0000	0x00FF_FFFF	16MB	3MB	Abort
TCM RAM + RAM ECC	CSRAM0	0x0800_0000	0x0BFF_FFFF	64MB	KB	
Mirrored Flash	Flash mirror frame	0x2000_0000	0x20FF_FFFF	16MB	MB	
External Memory Accesses						
EMIF Chip Select 2 (asynchronous)	EMIF select 2	0x6000_0000	0x63FF_FFFF	64MB	16MB	Access to "Reserved" space will generate Abort
EMIF Chip Select 3 (asynchronous)	EMIF select 3	0x6400_0000	0x67FF_FFFF	64MB	16MB	
EMIF Chip Select 4 (asynchronous)	EMIF select 4	0x6800_0000	0x6BFF_FFFF	64MB	16MB	
EMIF Chip Select 0 (synchronous)	EMIF select 0	0x8000_0000	0x87FF_FFFF	128MB	128MB	
Flash Module Bus2 Interface						
Customer OTP, TCM Flash Bank 0		0xF000_0000	0xF000_1FFF	8KB	4KB	Abort
Customer OTP, TCM Flash Bank 1		0xF000_2000	0xF000_3FFF	8KB	4KB	
Customer OTP, EEPROM Bank 7		0xF000_E000	0xF000_FFFF	8KB	4KB	
Customer OTP–ECC, TCM Flash Bank 0		0xF004_0000	0xF004_03FF	1KB	512B	
Customer OTP–ECC, TCM Flash Bank 1		0xF004_0400	0xF004_07FF	1KB	512B	
Customer OTP–ECC, EEPROM Bank 7		0xF004_1C00	0xF004_1FFF	1KB	1KB	
TI OTP, TCM Flash Bank 0		0xF008_0000	0xF008_1FFF	8KB	4KB	
TI OTP, TCM Flash Bank 1		0xF008_2000	0xF008_3FFF	8KB	4KB	
TI OTP, EEPROM Bank 7		0xF008_E000	0xF008_FFFF	8KB	4KB	
TI OTP–ECC, TCM Flash Bank 0		0xF00C_0000	0xF00C_03FF	1KB	512B	
TI OTP–ECC, TCM Flash Bank 1		0xF00C_0400	0xF00C_07FF	1KB	512B	
TI OTP–ECC, EEPROM Bank 7		0xF00C_1C00	0xF00C_1FFF	1KB	1KB	
EEPROM Bank–ECC		0xF010_0000	0xF013_FFFF	256KB	8KB	
EEPROM Bank		0xF020_0000	0xF03F_FFFF	2MB	64KB	
Flash Data Space ECC		0xF040_0000	0xF04F_FFFF	1MB	384KB	

Table 6-21. Device Memory Map (continued)

MODULE NAME	FRAME CHIP SELECT	FRAME ADDRESS RANGE		FRAME SIZE	ACTUAL SIZE	RESPONSE FOR ACCESS TO UNIMPLEMENTED LOCATIONS IN FRAME
		START	END			
EMIF Slave Interfaces						
CPPI Memory Slave (Ethernet RAM)		0xFC52_0000	0xFC52_1FFF	8KB	8KB	Abort
EMAC Slave (Ethernet Slave)		0xFCF7_8000	0xFCF7_87FF	2KB	2KB	No error
EMACSS Wrapper (Ethernet Wrapper)		0xFCF7_8800	0xFCF7_88FF	256B	256B	No error
Ethernet MDIO Interface		0xFCF7_8900	0xFCF7_89FF	256B	256B	No error
EMIF Registers		0xFCFF_E800	0xFCFF_E8FF	256B	256B	Abort
Cyclic Redundancy Checker (CRC) Module Registers						
CRC	CRC frame	0xFE00_0000	0xFEFF_FFFF	16MB	512B	Accesses above 0x200 generate abort.
Peripheral Memories						
MIBSPI5 RAM	PCS[5]	0xFF0A_0000	0xFF0B_FFFF	128KB	2KB	Abort for accesses above 2KB
MIBSPI3 RAM	PCS[6]	0xFF0C_0000	0xFF0D_FFFF	128KB	2KB	Abort for accesses above 2KB
MIBSPI1 RAM	PCS[7]	0xFF0E_0000	0xFF0F_FFFF	128KB	2KB	Abort for accesses above 2KB
DCAN3 RAM	PCS[13]	0xFF1A_0000	0xFF1B_FFFF	128KB	2KB	Wrap around for accesses to unimplemented address offsets lower than 0x7FF. Abort generated for accesses beyond offset 0x800.
DCAN2 RAM	PCS[14]	0xFF1C_0000	0xFF1D_FFFF	128KB	2KB	Wrap around for accesses to unimplemented address offsets lower than 0x7FF. Abort generated for accesses beyond offset 0x800.
DCAN1 RAM	PCS[15]	0xFF1E_0000	0xFF1F_FFFF	128KB	2KB	Wrap around for accesses to unimplemented address offsets lower than 0x7FF. Abort generated for accesses beyond offset 0x800.
MIBADC2 RAM	PCS[29]	0xFF3A_0000	0xFF3B_FFFF	128KB	8KB	Wrap around for accesses to unimplemented address offsets lower than 0x1FFF. Abort generated for accesses beyond 0x1FFF.
MIBADC1 RAM	PCS[31]	0xFF3E_0000	0xFF3F_FFFF	128KB	8KB	Wrap around for accesses to unimplemented address offsets lower than 0x1FFF. Abort generated for accesses beyond 0x1FFF.
N2HET2 RAM	PCS[34]	0xFF44_0000	0xFF45_FFFF	128KB	16KB	Wrap around for accesses to unimplemented address offsets lower than 0x3FFF. Abort generated for accesses beyond 0x3FFF.
N2HET1 RAM	PCS[35]	0xFF46_0000	0xFF47_FFFF	128KB	16KB	Wrap around for accesses to unimplemented address offsets lower than 0x3FFF. Abort generated for accesses beyond 0x3FFF.
N2HET2 TU2 RAM	PCS[38]	0xFF4C_0000	0xFF4D_FFFF	128KB	1KB	Abort
N2HET1 TU1 RAM	PCS[39]	0xFF4E_0000	0xFF4F_FFFF	128KB	1KB	Abort
FlexRay TU RAM	PCS[40]	0xFF50_0000	0xFF51_FFFF	128KB	1KB	Abort
Debug Components						
CoreSight Debug ROM	CSCS0	0xFFA0_0000	0xFFA0_0FFF	4KB	4KB	Reads: 0, writes: no effect

Table 6-21. Device Memory Map (continued)

MODULE NAME	FRAME CHIP SELECT	FRAME ADDRESS RANGE		FRAME SIZE	ACTUAL SIZE	RESPONSE FOR ACCESS TO UNIMPLEMENTED LOCATIONS IN FRAME
		START	END			
Cortex-R4F Debug	CSCS1	0xFFA0_1000	0xFFA0_1FFF	4KB	4KB	Reads: 0, writes: no effect
ETM-R4	CSCS2	0xFFA0_2000	0xFFA0_2FFF	4KB	4KB	Reads: 0, writes: no effect
CoreSight TPIU	CSCS3	0xFFA0_3000	0xFFA0_3FFF	4KB	4KB	Reads: 0, writes: no effect
POM	CSCS4	0xFFA0_4000	0xFFA0_4FFF	4KB	4KB	Abort
Peripheral Control Registers						
HTU1	PS[22]	0xFFF7_A400	0xFFF7_A4FF	256B	256B	Reads: 0, writes: no effect
HTU2	PS[22]	0xFFF7_A500	0xFFF7_A5FF	256B	256B	Reads: 0, writes: no effect
N2HET1	PS[17]	0xFFF7_B800	0xFFF7_B8FF	256B	256B	Reads: 0, writes: no effect
N2HET2	PS[17]	0xFFF7_B900	0xFFF7_B9FF	256B	256B	Reads: 0, writes: no effect
GPIO	PS[16]	0xFFF7_BC00	0xFFF7_BCFF	256B	256B	Reads: 0, writes: no effect
MIBADC1	PS[15]	0xFFF7_C000	0xFFF7_C1FF	512B	512B	Reads: 0, writes: no effect
MIBADC2	PS[15]	0xFFF7_C200	0xFFF7_C3FF	512B	512B	Reads: 0, writes: no effect
FlexRay	PS[12]+PS[13]	0xFFF7_C800	0xFFF7_CFFF	2KB	2KB	Reads: 0, writes: no effect
I2C	PS[10]	0xFFF7_D400	0xFFF7_D4FF	256B	256B	Reads: 0, writes: no effect
DCAN1	PS[8]	0xFFF7_DC00	0xFFF7_DDFD	512B	512B	Reads: 0, writes: no effect
DCAN2	PS[8]	0xFFF7_DE00	0xFFF7_DFFF	512B	512B	Reads: 0, writes: no effect
DCAN3	PS[7]	0xFFF7_E000	0xFFF7_E1FF	512B	512B	Reads: 0, writes: no effect
LIN	PS[6]	0xFFF7_E400	0xFFF7_E4FF	256B	256B	Reads: 0, writes: no effect
SCI	PS[6]	0xFFF7_E500	0xFFF7_E5FF	256B	256B	Reads: 0, writes: no effect
MibSPI1	PS[2]	0xFFF7_F400	0xFFF7_F5FF	512B	512B	Reads: 0, writes: no effect
SPI2	PS[2]	0xFFF7_F600	0xFFF7_F7FF	512B	512B	Reads: 0, writes: no effect
MibSPI3	PS[1]	0xFFF7_F800	0xFFF7_F9FF	512B	512B	Reads: 0, writes: no effect
SPI4	PS[1]	0xFFF7_FA00	0xFFF7_FBFF	512B	512B	Reads: 0, writes: no effect
MibSPI5	PS[0]	0xFFF7_FC00	0xFFF7_FDFD	512B	512B	Reads: 0, writes: no effect
System Modules Control Registers and Memories						
DMA RAM	PPCS0	0xFFF8_0000	0xFFF8_0FFF	4KB	4KB	Abort
VIM RAM	PPCS2	0xFFF8_2000	0xFFF8_2FFF	4KB	1KB	Wrap around for accesses to unimplemented address offsets between 1kB and 4kB.
RTP RAM	PPCS3	0xFFF8_3000	0xFFF8_3FFF	4KB	4KB	Abort
Flash Module	PPCS7	0xFFF8_7000	0xFFF8_7FFF	4KB	4KB	Abort
eFuse Controller	PPCS12	0xFFF8_C000	0xFFF8_CFFF	4KB	4KB	Abort
Power Management Module (PMM)	PPSE0	0xFFFF_0000	0xFFFF_01FF	512B	512B	Abort
Test Controller (FMTM)	PPSE1	0xFFFF_0400	0xFFFF_07FF	1KB	1KB	Reads: 0, writes: no effect
PCR registers	PPS0	0xFFFF_E000	0xFFFF_E0FF	256B	256B	Reads: 0, writes: no effect
System Module - Frame 2 (see device TRM)	PPS0	0xFFFF_E100	0xFFFF_E1FF	256B	256B	Reads: 0, writes: no effect
PBIST	PPS1	0xFFFF_E400	0xFFFF_E5FF	512B	512B	Reads: 0, writes: no effect
STC	PPS1	0xFFFF_E600	0xFFFF_E6FF	256B	256B	Generates address error interrupt, if enabled
IOMM Multiplexing Control Module	PPS2	0xFFFF_EA00	0xFFFF_EBFF	512B	512B	Reads: 0, writes: no effect
DCC1	PPS3	0xFFFF_EC00	0xFFFF_ECFF	256B	256B	Reads: 0, writes: no effect

Table 6-21. Device Memory Map (continued)

MODULE NAME	FRAME CHIP SELECT	FRAME ADDRESS RANGE		FRAME SIZE	ACTUAL SIZE	RESPONSE FOR ACCESS TO UNIMPLEMENTED LOCATIONS IN FRAME
		START	END			
DMA	PPS4	0xFFFF_F000	0xFFFF_F3FF	1KB	1KB	Reads: 0, writes: no effect
DCC2	PPS5	0xFFFF_F400	0xFFFF_F4FF	256B	256B	Reads: 0, writes: no effect
ESM	PPS5	0xFFFF_F500	0xFFFF_F5FF	256B	256B	Reads: 0, writes: no effect
CCMR4	PPS5	0xFFFF_F600	0xFFFF_F6FF	256B	256B	Reads: 0, writes: no effect
DMM	PPS5	0xFFFF_F700	0xFFFF_F7FF	256B	256B	Reads: 0, writes: no effect
RAM ECC even	PPS6	0xFFFF_F800	0xFFFF_F8FF	256B	256B	Reads: 0, writes: no effect
RAM ECC odd	PPS6	0xFFFF_F900	0xFFFF_F9FF	256B	256B	Reads: 0, writes: no effect
RTI + DWWD	PPS7	0xFFFF_FC00	0xFFFF_FCFF	256B	256B	Reads: 0, writes: no effect
VIM Parity	PPS7	0xFFFF_FD00	0xFFFF_FDFF	256B	256B	Reads: 0, writes: no effect
VIM	PPS7	0xFFFF_FE00	0xFFFF_FEFF	256B	256B	Reads: 0, writes: no effect
System Module - Frame 1 (see device TRM)	PPS7	0xFFFF_FF00	0xFFFF_FFFF	256B	256B	Reads: 0, writes: no effect

6.9.3 Master/Slave Access Privileges

The table below lists the access permissions for each bus master on the device. A bus master is a module that can initiate a read or a write transaction on the device.

Each slave module on the main interconnect is listed in the table. A "Yes" indicates that the module listed in the "MASTERS" column can access that slave module.

Table 6-22. Master / Slave Access Matrix

MASTERS	ACCESS MODE	SLAVES ON MAIN SCR				
		Flash Module Bus2 Interface: OTP, ECC, EEPROM Bank	Non-CPU Accesses to Program Flash and CPU Data RAM	CRC	Slave Interfaces	Peripheral Control Registers, All Peripheral Memories, and All System Module Control Registers and Memories
CPU READ	User/Privilege	Yes	Yes	Yes	Yes	Yes
CPU WRITE	User/Privilege	No	Yes	Yes	Yes	Yes
DMA	User	Yes	Yes	Yes	Yes	Yes
POM	User	Yes	Yes	Yes	Yes	Yes
DAP	Privilege	Yes	Yes	Yes	Yes	Yes
HTU1	Privilege	No	Yes	Yes	Yes	Yes
HTU2	Privilege	No	Yes	Yes	Yes	Yes

6.9.3.1 Special Notes on Accesses to Certain Slaves

Write accesses to the Power Domain Management Module (PMM) control registers are limited to the CPU (master id = 1). The other masters can only read from these registers.

A debugger can also write to the PMM registers. The master-id check is disabled in debug mode.

The device contains dedicated logic to generate a bus error response on any access to a module that is in a power domain that has been turned OFF.

6.9.4 POM Overlay Considerations

- The POM overlay can map onto up to 8MB of the internal or external memory space. The starting address and the size of the memory overlay are configurable via the POM module control registers. Care must be taken to ensure that the overlay is mapped on to available memory.
- ECC must be disabled by software via CP15 in case POM overlay is enabled; otherwise ECC errors will be generated.
- POM overlay must not be enabled when the flash and internal RAM memories are swapped via the MEM SWAP field of the Bus Matrix Module Control Register 1 (BMMCR1).
- When POM is used to overlay the flash onto internal or external RAM, there is a bus contention possibility when another master accesses the TCM flash. This results in a system hang.
 - The POM module implements a timeout feature to detect this exact scenario. The timeout needs to be enabled whenever POM overlay is enabled.
 - The timeout can be enabled by writing 1010 to the Enable TimeOut (ETO) field of the POM Global Control register (POMGLBCTRL, address = 0xFFA04000).
 - In case a read request by the POM cannot be completed within 32 HCLK cycles, the timeout (TO) flag is set in the POM Flag register (POMFLG, address = 0xFFA0400C). Also, an abort is generated to the CPU. This can be a prefetch abort for an instruction fetch or a data abort for a data fetch.
 - The prefetch- and data-abort handlers must be modified to check if the TO flag in the POM module is set. If so, then the application can assume that the timeout is caused by a bus contention between the POM transaction and another master accessing the same memory region. The abort handlers need to clear the TO flag, so that any further aborts are not misinterpreted as having been caused due to a timeout from the POM.

6.10 Flash Memory

6.10.1 Flash Memory Configuration

Flash Bank: A separate block of logic consisting of 1 to 16 sectors. Each flash bank normally has a customer-OTP and a TI-OTP area. These flash sectors share input/output buffers, data paths, sense amplifiers, and control logic.

Flash Sector: A contiguous region of flash memory which must be erased simultaneously due to physical construction constraints.

Flash Pump: A charge pump which generates all the voltages required for reading, programming, or erasing the flash banks.

Flash Module: Interface circuitry required between the host CPU and the flash banks and pump module.

Table 6-23. Flash Memory Banks and Sectors

Memory Arrays (or Banks) ⁽¹⁾	Sector No.	Segment	Low Address	High Address
BANK0 (1.5MBytes)	0	32K Bytes	0x0000_0000	0x0000_7FFF
	1	32K Bytes	0x0000_8000	0x0000_FFFF
	2	32K Bytes	0x0001_0000	0x0001_7FFF
	3	32K Bytes	0x0001_8000	0x0001_FFFF
	4	128K Bytes	0x0002_0000	0x0003_FFFF
	5	128K Bytes	0x0004_0000	0x0005_FFFF
	6	128K Bytes	0x0006_0000	0x0007_FFFF
	7	128K Bytes	0x0008_0000	0x0009_FFFF
	8	128K Bytes	0x000A_0000	0x000B_FFFF
	9	128K Bytes	0x000C_0000	0x000D_FFFF
	10	128K Bytes	0x000E_0000	0x000F_FFFF
	11	128K Bytes	0x0010_0000	0x0011_FFFF
	12	128K Bytes	0x0012_0000	0x0013_FFFF
	13	128K Bytes	0x0014_0000	0x0015_FFFF
14	128K Bytes	0x0016_0000	0x0017_FFFF	
BANK1 (1.5MBytes)	0	128K Bytes	0x0018_0000	0x0019_FFFF
	1	128K Bytes	0x001A_0000	0x001B_FFFF
	2	128K Bytes	0x001C_0000	0x001D_FFFF
	3	128K Bytes	0x001E_0000	0x001F_FFFF
	4	128K Bytes	0x0020_0000	0x0021_FFFF
	5	128K Bytes	0x0022_0000	0x0023_FFFF
	6	128K Bytes	0x0024_0000	0x0025_FFFF
	7	128K Bytes	0x0026_0000	0x0027_FFFF
	8	128K Bytes	0x0028_0000	0x0029_FFFF
	9	128K Bytes	0x002A_0000	0x002B_FFFF
	10	128K Bytes	0x002C_0000	0x002D_FFFF
11	128K Bytes	0x002E_0000	0x002F_FFFF	
BANK7 (64kBytes) for EEPROM emulation ⁽²⁾⁽³⁾	0	16K Bytes	0xF020_0000	0xF020_3FFF
	1	16K Bytes	0xF020_4000	0xF020_7FFF
	2	16K Bytes	0xF020_8000	0xF020_BFFF
	3	16K Bytes	0xF020_C000	0xF020_FFFF

(1) The Flash banks are 144-bit wide bank with ECC support.

(2) The flash bank7 can be programmed while executing code from flash bank0 or bank1.

(3) Code execution is not allowed from flash bank7.

6.10.2 Main Features of Flash Module

- Support for multiple flash banks for program and/or data storage
- Simultaneous read access on a bank while performing program or erase operation on any other bank
- Integrated state machines to automate flash erase and program operations
- Software interface for flash program and erase operations
- Pipelined mode operation to improve instruction access interface bandwidth
- Support for Single Error Correction Double Error Detection (SECCDED) block inside Cortex-R4F CPU
 - Error address is captured for host system debugging
- Support for a rich set of diagnostic features

6.10.3 ECC Protection for Flash Accesses

All accesses to the program flash memory are protected by Single Error Correction Double Error Detection (SECCDED) logic embedded inside the CPU. The flash module provides 8 bits of ECC code for 64 bits of instructions or data fetched from the flash memory. The CPU calculates the expected ECC code based on the 64 bits received and compares it with the ECC code returned by the flash module. A single-bit error is corrected and flagged by the CPU, while a multi-bit error is only flagged. The CPU signals an ECC error via its Event bus. This signaling mechanism is not enabled by default and must be enabled by setting the "X" bit of the Performance Monitor Control Register, c9.

```
MRC p15, #0, r1, c9, c12, #0      ;Enabling Event monitor states
ORR r1, r1, #0x00000010
MCR p15, #0, r1, c9, c12, #0      ;Set 4th bit ('X') of PMNC register
MRC p15, #0, r1, c9, c12, #0
```

The application must also explicitly enable the CPU's ECC checking for accesses on the CPU's ATCM and BTCM interfaces. These are connected to the program flash and data RAM respectively. ECC checking for these interfaces can be done by setting the B1TCMPCEN, B0TCMPCEN and ATCMPCEN bits of the System Control coprocessor's Auxiliary Control Register, c1.

```
MRC p15, #0, r1, c1, c0, #1
ORR r1, r1, #0x0e000000          ;Enable ECC checking for ATCM and BTCMs
DMB
MCR p15, #0, r1, c1, c0, #1
```

6.10.4 Flash Access Speeds

For information on flash memory access speeds and the relevant wait states required, refer to [Section 5.8](#).

6.10.5 Flash Program and Erase Timings for Program Flash

Table 6-24. Timing Specifications for Program Flash

		MIN	NOM	MAX	UNIT
t _{prog} (144 bit)	Wide Word (144 bit) programming time		40	300	μs
t _{prog} (Total)	3MByte programming time ⁽¹⁾	-40°C to 125°C		32	s
		0°C to 60°C, for first 25 cycles	8	16	s
t _{erase}	Sector/Bank erase time ⁽²⁾	-40°C to 125°C	0.03	4	s
		0°C to 60°C, for first 25 cycles	16	100	ms
t _{wec}	Write/erase cycles	-40°C to 125°C		1000	cycles
t _{ret}	Data retention ⁽³⁾	125°C		5	years

- (1) This programming time includes overhead of state machine, but does not include data transfer time. The programming time assumes programming 144 bits at a time at the maximum specified operating frequency.
- (2) During bank erase, the selected sectors are erased simultaneously. The time to erase the bank is specified as equal to the time to erase a sector.
- (3) The data retention specification is based on process qualification testing at 250°C for 168 hours and using an Arrhenius model with activation energy of 0.8 eV.

6.10.6 Flash Program and Erase Timings for Data Flash

Table 6-25. Timing Specifications for Data Flash

			MIN	NOM	MAX	UNIT
t_{prog} (144 bit)	Wide Word (144 bit) programming time			40	300	μs
t_{prog} (Total)	64KB programming time ⁽¹⁾	-40°C to 125°C			660	ms
		0°C to 60°C, for first 25 cycles		165	330	ms
t_{erase}	Sector/Bank erase time ⁽²⁾	--40°C to 125°C		0.2	8	s
		0°C to 60°C, for first 25 cycles		14	100	ms
t_{wec}	Write/erase cycles	-40°C to 125°C			100000	cycles
t_{ret}	Data retention ⁽³⁾	125°C			5	years

- (1) This programming time includes overhead of state machine, but does not include data transfer time. The programming time assumes programming 144 bits at a time at the maximum specified operating frequency.
- (2) During bank erase, the selected sectors are erased simultaneously. The time to erase the bank is specified as equal to the time to erase a sector.
- (3) The data retention specification is based on process qualification testing at 250°C for 168 hours and using an Arrhenius model with activation energy of 0.8 eV.

6.11 Tightly-Coupled RAM Interface Module

Figure 6-10 illustrates the connection of the tightly coupled RAM (TCRAM) to the Cortex-R4F CPU.

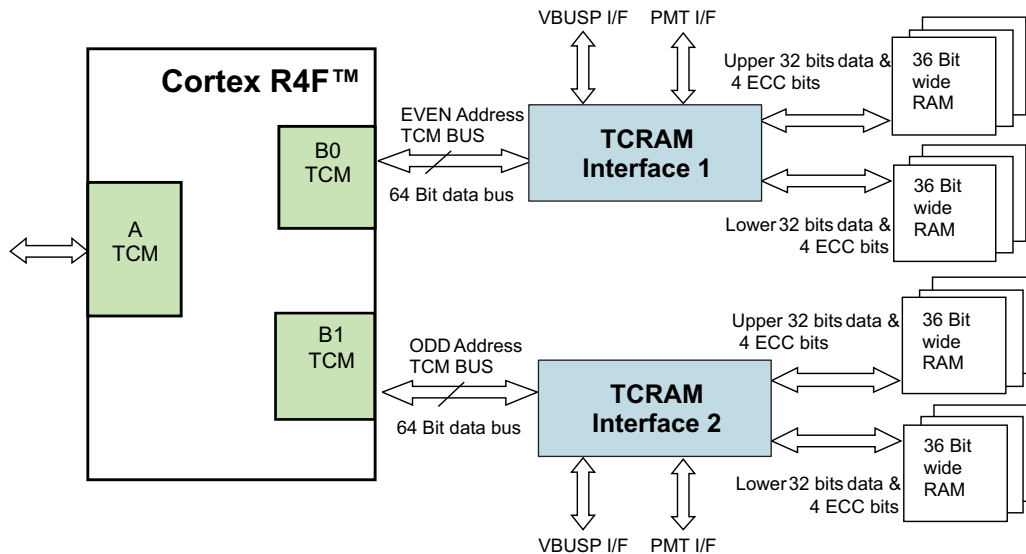

Figure 6-10. TCRAM Block Diagram

6.11.1 Features

The features of the Tightly Coupled RAM (TCRAM) Module are:

- Acts as slave to the Cortex-R4F CPU's BTCM interface
- Supports CPU's internal ECC scheme by providing 64-bit data and 8-bit ECC code
- Monitors CPU Event Bus and generates single or multi-bit errors
- Stores addresses for single and multi-bit errors
- Supports RAM trace module
- Provides CPU address bus integrity checking by supporting parity checking on the address bus
- Performs redundant address decoding for the RAM bank chip select and ECC select generation logic
- Provides enhanced safety for the RAM addressing by implementing two 36-bit wide byte-interleaved RAM banks and generating independent RAM access control signals to the two banks
- Supports auto-initialization of the RAM banks along with the ECC bits
- No support for bit-wise RAM accesses

6.11.2 TCRAMW ECC Support

The TCRAMW passes on the ECC code for each data read by the Cortex-R4F CPU from the RAM. It also stores the CPU's ECC port contents in the ECC RAM when the CPU does a write to the RAM. The TCRAMW monitors the CPU's event bus and provides registers for indicating single/multi-bit errors and also for identifying the address that caused the single or multi-bit error. The event signaling and the ECC checking for the RAM accesses must be enabled inside the CPU.

For more information see the device specific technical reference manual.

6.12 Parity Protection for Peripheral RAMs

Most peripheral RAMs are protected by odd/even parity checking. During a read access the parity is calculated based on the data read from the peripheral RAM and compared with the good parity value stored in the parity RAM for that peripheral. If any word fails the parity check, the module generates a parity error signal that is mapped to the Error Signaling Module. The module also captures the peripheral RAM address that caused the parity error.

The parity protection for peripheral RAMs is not enabled by default and must be enabled by the application. Each individual peripheral contains control registers to enable the parity protection for accesses to its RAM.

NOTE

The CPU read access gets the actual data from the peripheral. The application can choose to generate an interrupt whenever a peripheral RAM parity error is detected.

6.13 On-Chip SRAM Initialization and Testing

6.13.1 On-Chip SRAM Self-Test Using PBIST

6.13.1.1 Features

- Extensive instruction set to support various memory test algorithms
- ROM-based algorithms allow application to run TI production-level memory tests
- Independent testing of all on-chip SRAM

6.13.1.2 PBIST RAM Groups

Table 6-26. PBIST RAM Grouping

Memory	RAM Group	Test Clock	MEM Type	Test Pattern (Algorithm)			
				triple read slow read	triple read fast read	March 13N ⁽¹⁾ two port (cycles)	March 13N ⁽¹⁾ single port (cycles)
				ALGO MASK 0x1	ALGO MASK 0x2	ALGO MASK 0x4	ALGO MASK 0x8
PBIST_ROM	1	ROM CLK	ROM	24578	8194		
STC_ROM	2	ROM CLK	ROM	19586	6530		
DCAN1	3	VCLK	Dual Port			25200	
DCAN2	4	VCLK	Dual Port			25200	
DCAN3	5	VCLK	Dual Port			25200	
ESRAM1	6	HCLK	Single Port				266280
MIBSPI1	7	VCLK	Dual Port			33440	
MIBSPI3	8	VCLK	Dual Port			33440	
MIBSPI5	9	VCLK	Dual Port			33440	
VIM	10	VCLK	Dual Port			12560	
MIBADC1	11	VCLK	Dual Port			4200	
DMA	12	HCLK	Dual Port			18960	
N2HET1	13	VCLK	Dual Port			31680	
HET TU1	14	VCLK	Dual Port			6480	
RTP	15	HCLK	Dual Port			37800	
FLEXRAY	16	VCLK	Dual Port			75400	
	17		Single Port				133160
MIBADC2	18	VCLK	Dual Port			4200	
N2HET2	19	VCLK	Dual Port			31680	
HET TU2	20	VCLK	Dual Port			6480	
ESRAM5	21	HCLK	Single Port				266280
ESRAM6	22	HCLK	Single Port				266280
ETHERNET	23	VCLK3	Dual Port			8700	
	24				6360		
	25		Single Port				133160
ESRAM8	28	HCLK	Single Port				266280

(1) There are several memory testing algorithms stored in the PBIST ROM. However, TI recommends the March13N algorithm for application testing.

The PBIST ROM clock frequency is limited to 90MHz, if $90\text{MHz} < \text{HCLK} \leq \text{HCLK}_{\text{max}}$, or HCLK, if $\text{HCLK} \leq 90\text{MHz}$.

The PBIST ROM clock is divided down from HCLK. The divider is selected by programming the ROM_DIV field of the Memory Self-Test Global Control Register (MSTGCR) at address 0xFFFFF58.

6.13.2 On-Chip SRAM Auto Initialization

This microcontroller allows some of the on-chip memories to be initialized to zero via the Memory Hardware Initialization mechanism in the System module. This hardware mechanism allows an application to program the memory arrays with error detection capability to a known state based on their error detection scheme (odd/even parity or ECC).

The MINITGCR register enables the memory initialization sequence, and the MSINENA register selects the memories that are to be initialized.

For more information on these registers see the device specific technical reference manual.

The mapping of the different on-chip memories to the specific bits of the MSINENA registers is shown in [Table 6-27](#).

Table 6-27. Memory Initialization

CONNECTING MODULE	ADDRESS RANGE		MSINENA REGISTER BIT #
	BASE ADDRESS	ENDING ADDRESS	
RAM (PD#1)	0x08000000	0x0800FFFF	0 ⁽¹⁾
RAM (RAM_PD#1)	0x08010000	0x0801FFFF	0 ⁽¹⁾
RAM (RAM_PD#2)	0x08020000	0x0802FFFF	0 ⁽¹⁾
MIBSPI5 RAM	0xFF0A0000	0xFF0BFFFF	12 ⁽²⁾
MIBSPI3 RAM	0xFF0C0000	0xFF0DFFFF	11 ⁽²⁾
MIBSPI1 RAM	0xFF0E0000	0xFF0FFFFF	7 ⁽²⁾
DCAN3 RAM	0xFF1A0000	0xFF1BFFFF	10
DCAN2 RAM	0xFF1C0000	0xFF1DFFFF	6
DCAN1 RAM	0xFF1E0000	0xFF1FFFFF	5
FlexRay RAM	RAM is not CPU-Addressable		n/a ⁽³⁾
MIBADC2 RAM	0xFF3A0000	0xFF3BFFFF	14
MIBADC1 RAM	0xFF3E0000	0xFF3FFFFF	8
N2HET2 RAM	0xFF440000	0xFF47FFFF	15
N2HET1 RAM	0xFF460000	0xFF47FFFF	3
HET TU2 RAM	0xFF4C0000	0xFF4DFFFF	16
HET TU1 RAM	0xFF4E0000	0xFF4FFFFF	4
DMA RAM	0xFFF80000	0xFFF80FFF	1
VIM RAM	0xFFF82000	0xFFF82FFF	2
RTP RAM	0xFFF83000	0xFFF83FFF	n/a
FlexRay TU RAM	0xFF500000	0xFF51FFFF	13
Ethernet RAM (CPPI Memory Slave)	0xFC520000	0xFC521FFF	n/a

- (1) The TCM RAM wrapper has separate control bits to select the RAM power domain that is to be auto-initialized.
- (2) The MibSPIx modules perform an initialization of the transmit and receive RAMs as soon as the module is released from its local reset via the SPIGCR0 register. This is independent of whether the application chooses to initialize the MibSPIx RAMs using the system module auto-initialization method. Before the MibSPI RAM can be initialized using the system module auto-initialization method: (i) The module must be released from its local reset, AND (ii) The application must poll for the "BUF INIT ACTIVE" status flag in the SPIFLG register to become cleared (zero)
- (3) Reserved only. The FlexRay RAM has its own initialization mechanism.

6.14 External Memory Interface (EMIF)

6.14.1 Features

The EMIF includes many features to enhance the ease and flexibility of connecting to external asynchronous memories or SDRAM devices. The EMIF features includes support for:

- 3 addressable chip select for asynchronous memories of up to 16MB each
- 1 addressable chip select space for SDRAMs up to 128MB
- 8 or 16-bit data bus width
- Programmable cycle timings such as setup, strobe, and hold times as well as turnaround time
- Select strobe mode
- Extended Wait mode
- Data bus parking

6.14.2 Electrical and Timing Specifications

6.14.2.1 Asynchronous RAM

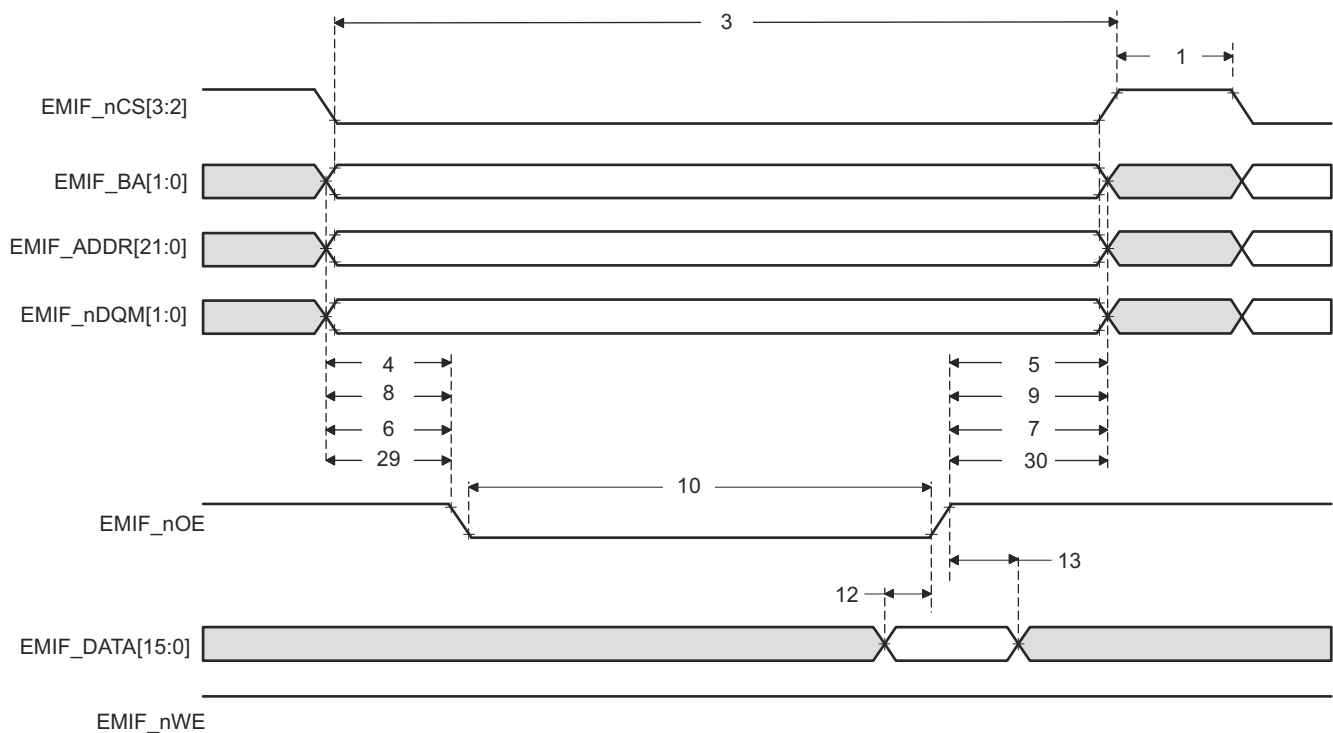

Figure 6-11. Asynchronous Memory Read Timing

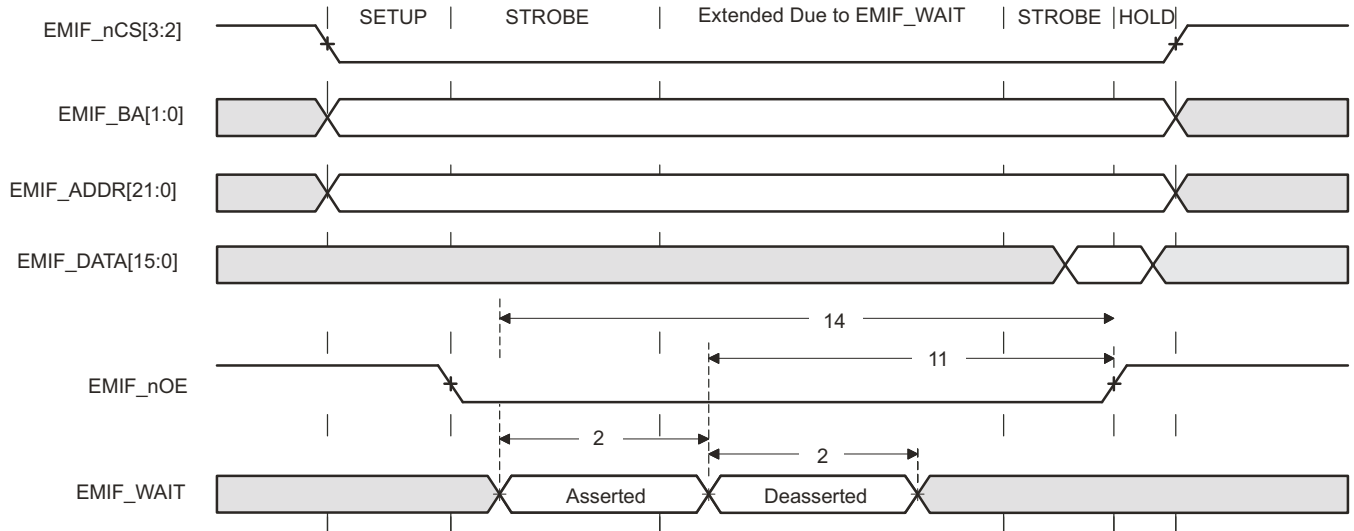

Figure 6-12. EMIFnWAIT Read Timing Requirements

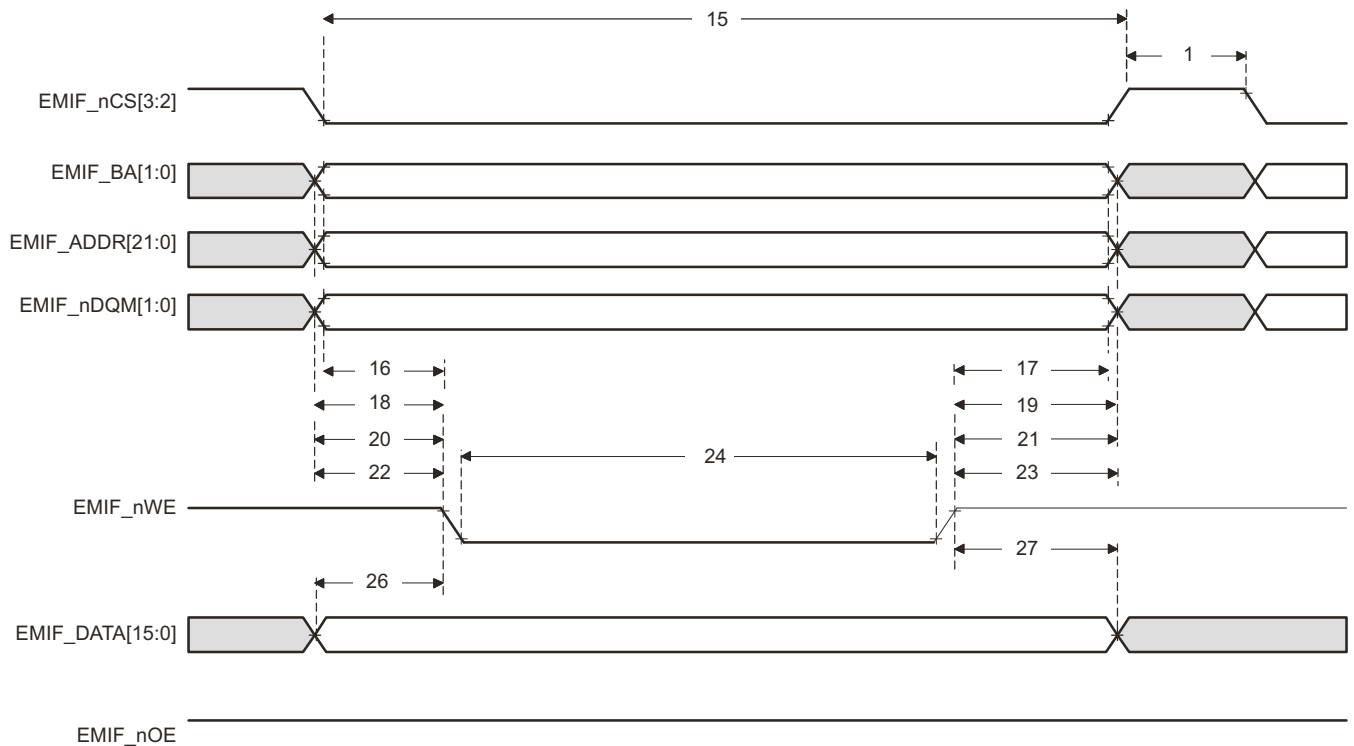

Figure 6-13. Asynchronous Memory Write Timing

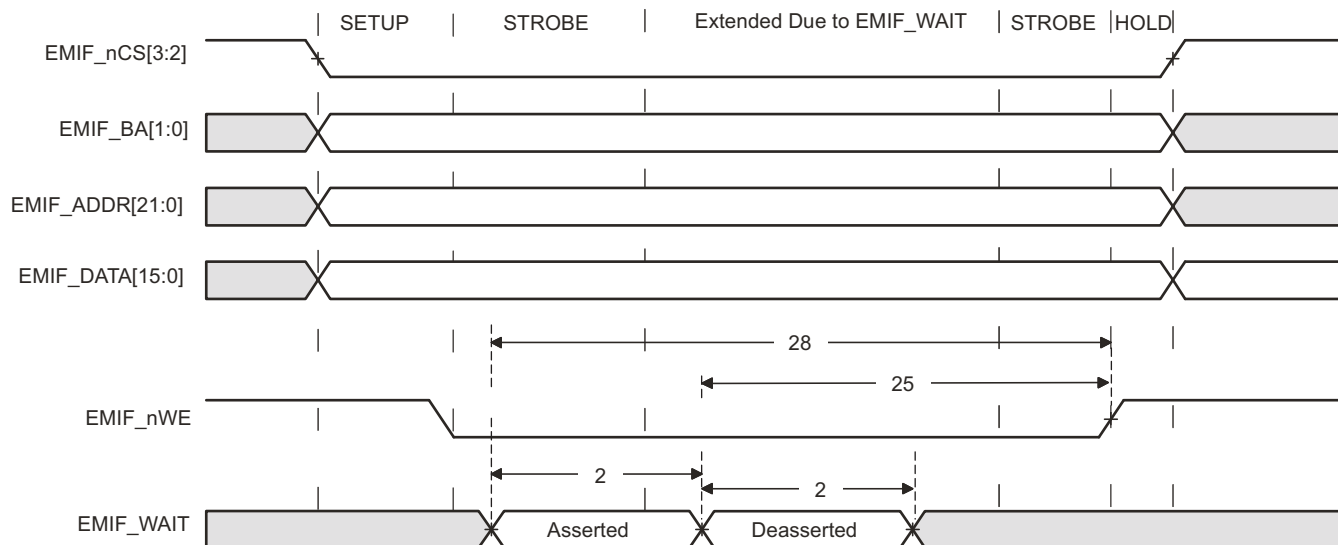

Figure 6-14. EMIFnWAIT Write Timing Requirements

Table 6-28. EMIF Asynchronous Memory Timing Requirements

NO.			MIN	NOM	MAX	UNIT
Reads and Writes						
	E	EMIF clock period				ns
2	$t_{w(EM_WAIT)}$	Pulse duration, EMIFnWAIT assertion and deassertion	2E			ns
Reads						
12	$t_{su(EMDV-EMOEH)}$	Setup time, EMIFDATA[15:0] valid before EMIFnOE high	30			ns
13	$t_{h(EMOEH-EMDIV)}$	Hold time, EMIFDATA[15:0] valid after EMIFnOE high	0.5			ns
14	$t_{su(EMOEL-EMWAIT)}$	Setup Time, EMIFnWAIT asserted before end of Strobe Phase ⁽¹⁾	4E+30			ns
Writes						
28	$t_{su(EMWEL-EMWAIT)}$	Setup Time, EMIFnWAIT asserted before end of Strobe Phase ⁽¹⁾	4E+30			ns

(1) Setup before end of STROBE phase (if no extended wait states are inserted) by which EMIFnWAIT must be asserted to add extended wait states. Figure Figure 6-12 and Figure Figure 6-14 describe EMIF transactions that include extended wait states inserted during the STROBE phase. However, cycles inserted as part of this extended wait period should not be counted; the 4E requirement is to the start of where the HOLD phase would begin if there were no extended wait cycles.

Table 6-29. EMIF Asynchronous Memory Switching Characteristics⁽¹⁾⁽²⁾⁽³⁾

NO.	PARAMETER		MIN	NOM	MAX	UNIT
Reads and Writes						
1	$t_{d(TURNAROUND)}$	Turn around time	(TA) × E - 4	(TA) × E	(TA) × E + 3	ns
Reads						

(1) TA = Turn around, RS = Read setup, RST = Read strobe, RH = Read hold, WS = Write setup, WST = Write strobe, WH = Write hold, MEWC = Maximum external wait cycles. These parameters are programmed via the Asynchronous Bank and Asynchronous Wait Cycle Configuration Registers. These support the following ranges of values: TA[4–1], RS[16–1], RST[64–1], RH[8–1], WS[16–1], WST[64–1], WH[8–1], and MEWC[1–256]. See the for more information.

(2) E = EMIF_CLK period in ns.

(3) EWC = external wait cycles determined by EMIFnWAIT input signal. EWC supports the following range of values. EWC[256–1]. Note that the maximum wait time before timeout is specified by bit field MEWC in the Asynchronous Wait Cycle Configuration Register. See the for more information.

Table 6-29. EMIF Asynchronous Memory Switching Characteristics⁽¹⁾⁽²⁾⁽³⁾ (continued)

NO.	PARAMETER		MIN	NOM	MAX	UNIT
3	$t_{c(EMRCYCLE)}$	EMIF read cycle time (EW = 0)	$(RS+RST+RH) \times E^{-3}$	$(RS+RST+RH) \times E$	$(RS+RST+RH) \times E + 3$	ns
		EMIF read cycle time (EW = 1)	$(RS+RST+RH+(EWC \times 16)) \times E^{-3}$	$(RS+RST+RH+(EWC \times 16)) \times E$	$(RS+RST+RH+(EWC \times 16)) \times E + 3$	ns
4	$t_{su(EMCEL-EMOEL)}$	Output setup time, EMIFnCS[4:2] low to EMIFnOE low (SS = 0)	$(RS) \times E^{-4}$	$(RS) \times E$	$(RS) \times E + 3$	ns
		Output setup time, EMIFnCS[4:2] low to EMIFnOE low (SS = 1)	-3	0	+3	ns
5	$t_{h(EMOEH-EMCEH)}$	Output hold time, EMIFnOE high to EMIFnCS[4:2] high (SS = 0)	$(RH) \times E^{-4}$	$(RH) \times E$	$(RH) \times E + 3$	ns
		Output hold time, EMIFnOE high to EMIFnCS[4:2] high (SS = 1)	-3	0	+3	ns
6	$t_{su(EMBAV-EMOEL)}$	Output setup time, EMIFBA[1:0] valid to EMIFnOE low	$(RS) \times E^{-4}$	$(RS) \times E$	$(RS) \times E + 3$	ns
7	$t_{h(EMOEH-EMBAIV)}$	Output hold time, EMIFnOE high to EMIFBA[1:0] invalid	$(RH) \times E^{-4}$	$(RH) \times E$	$(RH) \times E + 3$	ns
8	$t_{su(EMAV-EMOEL)}$	Output setup time, EMIFADDR[21:0] valid to EMIFnOE low	$(RS) \times E^{-4}$	$(RS) \times E$	$(RS) \times E + 3$	ns
9	$t_{h(EMOEH-EMAIV)}$	Output hold time, EMIFnOE high to EMIFADDR[21:0] invalid	$(RH) \times E^{-4}$	$(RH) \times E$	$(RH) \times E + 3$	ns
10	$t_{w(EMOEL)}$	EMIFnOE active low width (EW = 0)	$(RST) \times E^{-3}$	$(RST) \times E$	$(RST) \times E + 3$	ns
		EMIFnOE active low width (EW = 1)	$(RST+(EWC \times 16)) \times E^{-3}$	$(RST+(EWC \times 16)) \times E$	$(RST+(EWC \times 16)) \times E + 3$	ns
11	$t_{d(EMWAITH-EMOEH)}$	Delay time from EMIFnWAIT deasserted to EMIFnOE high	3E-3	4E	4E+30	ns
29	$t_{su(EMDQMV-EMOEL)}$	Output setup time, EMIFnDQM[1:0] valid to EMIFnOE low	$(RS) \times E^{-4}$	$(RS) \times E$	$(RS) \times E + 3$	ns
30	$t_{h(EMOEH-EMDQMV)}$	Output hold time, EMIFnOE high to EMIFnDQM[1:0] invalid	$(RH) \times E^{-4}$	$(RH) \times E$	$(RH) \times E + 3$	ns
Writes						
15	$t_{c(EMWCYCLE)}$	EMIF write cycle time (EW = 0)	$(WS+WST+WH) \times E^{-3}$	$(WS+WST+WH) \times E$	$(WS+WST+WH) \times E + 3$	ns
		EMIF write cycle time (EW = 1)	$(WS+WST+WH+(EWC \times 16)) \times E^{-3}$	$(WS+WST+WH+(EWC \times 16)) \times E$	$(WS+WST+WH+(EWC \times 16)) \times E + 3$	ns
16	$t_{su(EMCEL-EMWEL)}$	Output setup time, EMIFnCS[4:2] low to EMIFnWE low (SS = 0)	$(WS) \times E^{-4}$	$(WS) \times E$	$(WS) \times E + 3$	ns
		Output setup time, EMIFnCS[4:2] low to EMIFnWE low (SS = 1)	-4	0	+3	ns
17	$t_{h(EMWEH-EMCEH)}$	Output hold time, EMIFnWE high to EMIFnCS[4:2] high (SS = 0)	$(WH) \times E^{-4}$	$(WH) \times E$	$(WH) \times E + 3$	ns
		Output hold time, EMIFnWE high to EMIFCS[4:2] high (SS = 1)	-4	0	+3	ns
18	$t_{su(EMDQMV-EMWEL)}$	Output setup time, EMIFBA[1:0] valid to EMIFnWE low	$(WS) \times E^{-4}$	$(WS) \times E$	$(WS) \times E + 3$	ns
19	$t_{h(EMWEH-EMDQMV)}$	Output hold time, EMIFnWE high to EMIFBA[1:0] invalid	$(WH) \times E^{-4}$	$(WH) \times E$	$(WH) \times E + 3$	ns

Table 6-29. EMIF Asynchronous Memory Switching Characteristics⁽¹⁾⁽²⁾⁽³⁾ (continued)

NO.	PARAMETER	MIN	NOM	MAX	UNIT
20	$t_{su}(EMBAV-EMWEL)$	$(WS) \times E-4$	$(WS) \times E$	$(WS) \times E+3$	ns
21	$t_h(EMWEH-EMBAIV)$	$(WH) \times E-4$	$(WH) \times E$	$(WH) \times E+3$	ns
22	$t_{su}(EMAV-EMWEL)$	$(WS) \times E-4$	$(WS) \times E$	$(WS) \times E+3$	ns
23	$t_h(EMWEH-EMAIV)$	$(WH) \times E-4$	$(WH) \times E$	$(WH) \times E+3$	ns
24	$t_w(EMWEL)$	$(WST) \times E-3$	$(WST) \times E$	$(WST) \times E+3$	ns
	EMIFnWE active low width (EW = 1)	$(WST+(EWC \times 16)) \times E-3$	$(WST+(EWC \times 16)) \times E$	$(WST+(EWC \times 16)) \times E+3$	ns
25	$t_d(EMWAITH-EMWEH)$	3E-4	4E	4E+30	ns
26	$t_{su}(EMDV-EMWEL)$	$(WS) \times E-4$	$(WS) \times E$	$(WS) \times E+3$	ns
27	$t_h(EMWEH-EMDIV)$	$(WH) \times E-4$	$(WH) \times E$	$(WH) \times E+3$	ns
31	$t_{su}(EMDQMV-EMWEL)$	$(WH) \times E-4$	$(WH) \times E$	$(WH) \times E+3$	ns
32	$t_h(EMWEH-EMDQIV)$	$(WH) \times E-4$	$(WH) \times E$	$(WH) \times E+3$	ns

6.14.2.2 Synchronous Timing

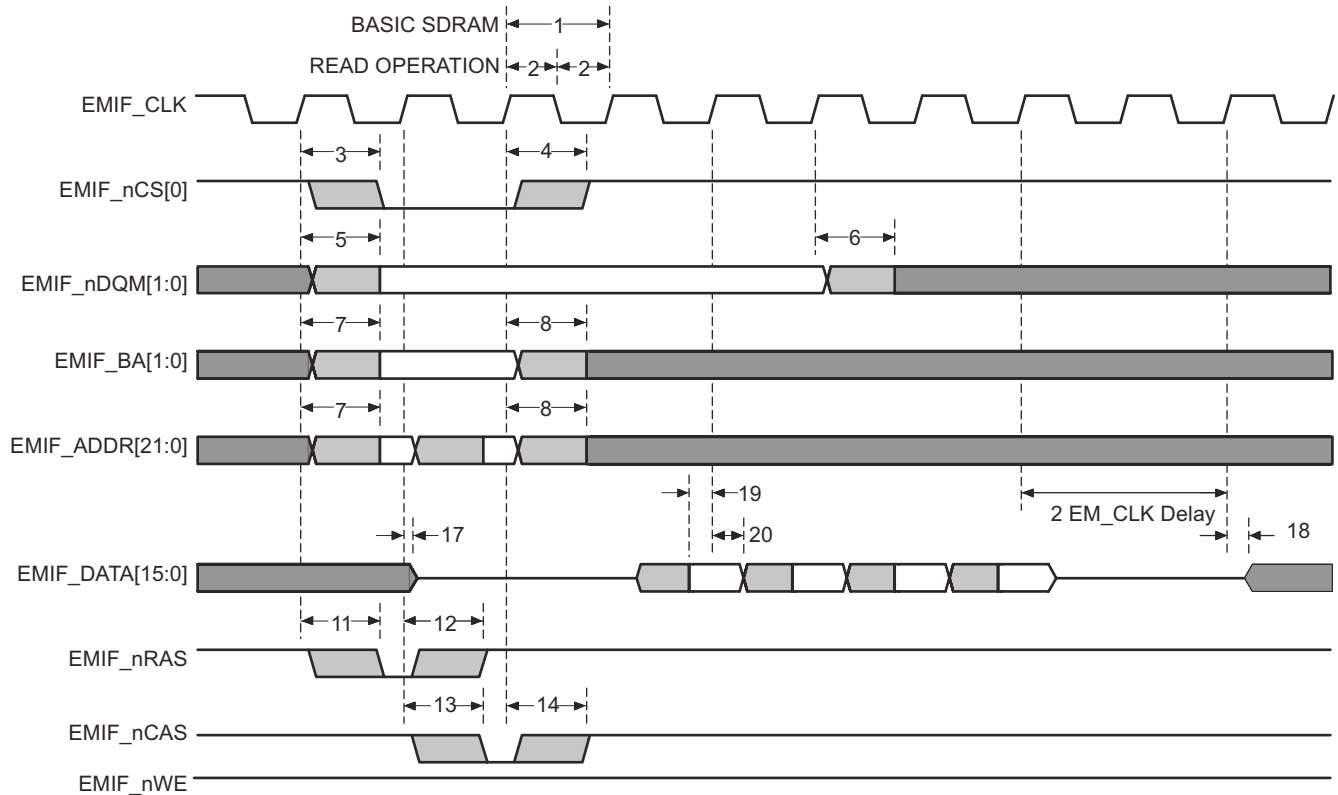

Figure 6-15. Basic SDRAM Read Operation

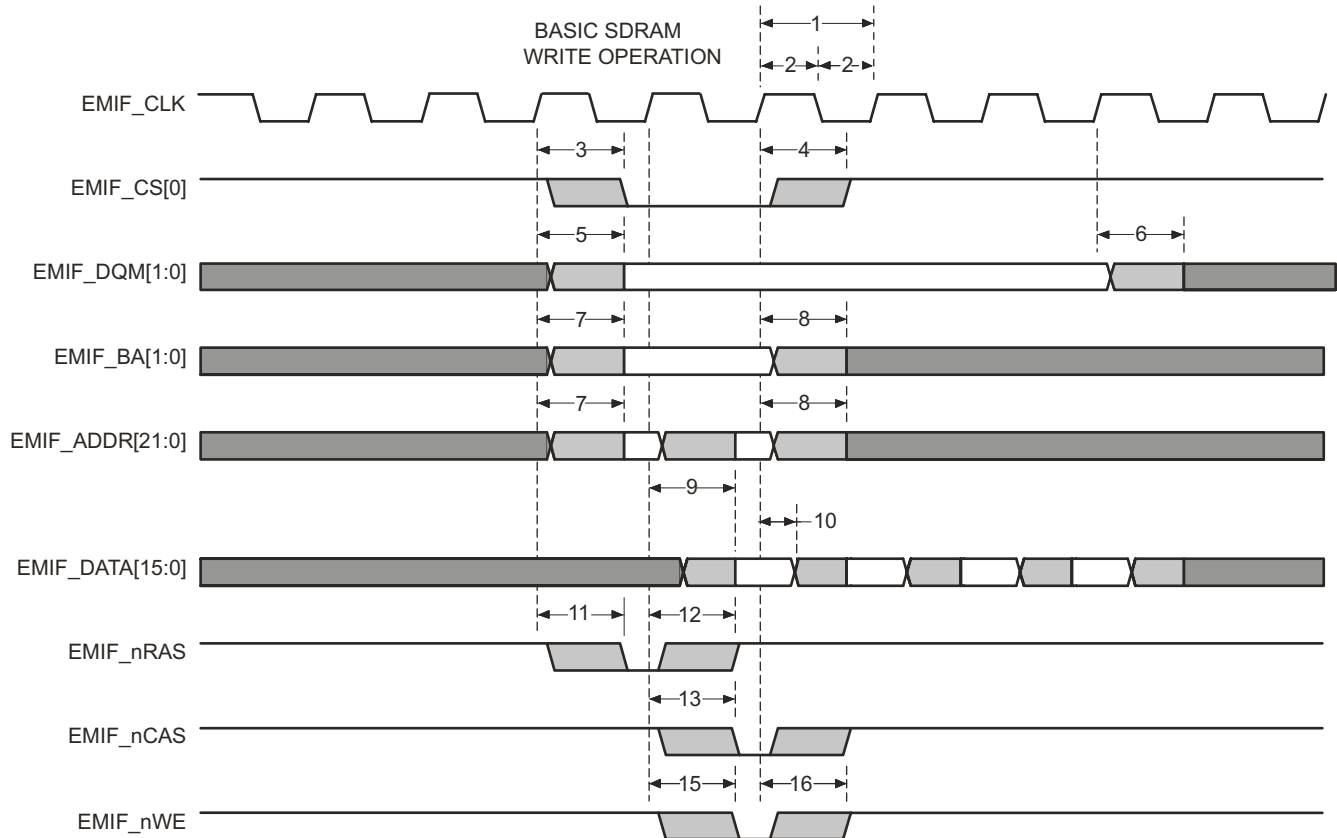

Figure 6-16. Basic SDRAM Write Operation

Table 6-30. EMIF Synchronous Memory Timing Requirements

NO.	PARAMETER	MIN	MAX	UNIT
19	$t_{su}(EMIFDV-EM_CLKH)$ Input setup time, read data valid on EMIFDATA[15:0] before EMIF_CLK rising	2		ns
20	$t_h(CLKH-DIV)$ Input hold time, read data valid on EMIFDATA[15:0] after EMIF_CLK rising	1.5		ns

Table 6-31. EMIF Synchronous Memory Switching Characteristics

NO.	PARAMETER	MIN	MAX	UNIT
1	$t_c(CLK)$ Cycle time, EMIF clock EMIF_CLK			ns
2	$t_w(CLK)$ Pulse width, EMIF clock EMIF_CLK high or low	5		ns
3	$t_d(CLKH-CSV)$ Delay time, EMIF_CLK rising to EMIFnCS[0] valid		13	ns
4	$t_{oh}(CLKH-CSIV)$ Output hold time, EMIF_CLK rising to EMIFnCS[0] invalid	1		ns
5	$t_d(CLKH-DQMV)$ Delay time, EMIF_CLK rising to EMIFnDQM[1:0] valid		13	ns
6	$t_{oh}(CLKH-DQMIV)$ Output hold time, EMIF_CLK rising to EMIFnDQM[1:0] invalid	1		ns
7	$t_d(CLKH-AV)$ Delay time, EMIF_CLK rising to EMIFADDR[21:0] and EMIFBA[1:0] valid		13	ns
8	$t_{oh}(CLKH-AIV)$ Output hold time, EMIF_CLK rising to EMIFADDR[21:0] and EMIFBA[1:0] invalid	1		ns
9	$t_d(CLKH-DV)$ Delay time, EMIF_CLK rising to EMIFDATA[15:0] valid		13	ns
10	$t_{oh}(CLKH-DIV)$ Output hold time, EMIF_CLK rising to EMIFDATA[15:0] invalid	1		ns
11	$t_d(CLKH-RASV)$ Delay time, EMIF_CLK rising to EMIFnRAS valid		13	ns
12	$t_{oh}(CLKH-RASIV)$ Output hold time, EMIF_CLK rising to EMIFnRAS invalid	1		ns
13	$t_d(CLKH-CASV)$ Delay time, EMIF_CLK rising to EMIFnCAS valid		13	ns

Table 6-31. EMIF Synchronous Memory Switching Characteristics (continued)

NO.	PARAMETER		MIN	MAX	UNIT
14	$t_{oh(CLKH-CASIV)}$	Output hold time, EMIF_CLK rising to EMIFnCAS invalid	1		ns
15	$t_d(CLKH-WEV)$	Delay time, EMIF_CLK rising to EMIFnWE valid		13	ns
16	$t_{oh(CLKH-WEIV)}$	Output hold time, EMIF_CLK rising to EMIFnWE invalid	1		ns
17	$t_{dis(CLKH-DHZ)}$	Delay time, EMIF_CLK rising to EMIFDATA[15:0] tri-stated		7	ns
18	$t_{ena(CLKH-DLZ)}$	Output hold time, EMIF_CLK rising to EMIFDATA[15:0] driving	1		ns

6.15 Vectored Interrupt Manager

The vectored interrupt manager (VIM) provides hardware assistance for prioritizing and controlling the many interrupt sources present on this device. Interrupts are caused by events outside of the normal flow of program execution. Normally, these events require a timely response from the central processing unit (CPU); therefore, when an interrupt occurs, the CPU switches execution from the normal program flow to an interrupt service routine (ISR).

6.15.1 VIM Features

The VIM module has the following features:

- Supports 96 interrupt channels.
 - Provides programmable priority and enable for interrupt request lines.
- Provides a direct hardware dispatch mechanism for fastest IRQ dispatch.
- Provides two software dispatch mechanisms when the CPU VIC port is not used.
 - Index interrupt
 - Register vectored interrupt
- Parity protected vector interrupt table

6.15.2 Interrupt Request Assignments

Table 6-32. Interrupt Request Assignments

Modules	Interrupt Sources	Default VIM Interrupt Channel
ESM	ESM High level interrupt (NMI)	0
Reserved	Reserved	1
RTI	RTI compare interrupt 0	2
RTI	RTI compare interrupt 1	3
RTI	RTI compare interrupt 2	4
RTI	RTI compare interrupt 3	5
RTI	RTI overflow interrupt 0	6
RTI	RTI overflow interrupt 1	7
RTI	RTI timebase interrupt	8
GPIO	GPIO interrupt A	9
N2HET1	N2HET1 level 0 interrupt	10
HET TU1	HET TU1 level 0 interrupt	11
MIBSPI1	MIBSPI1 level 0 interrupt	12
LIN	LIN level 0 interrupt	13
MIBADC1	MIBADC1 event group interrupt	14
MIBADC1	MIBADC1 sw group 1 interrupt	15
DCAN1	DCAN1 level 0 interrupt	16
SPI2	SPI2 level 0 interrupt	17
FlexRay	FlexRay level 0 interrupt	18
CRC	CRC Interrupt	19
ESM	ESM Low level interrupt	20
SYSTEM	Software interrupt (SSI)	21
CPU	PMU Interrupt	22
GPIO	GPIO interrupt B	23
N2HET1	N2HET1 level 1 interrupt	24
HET TU1	HET TU1 level 1 interrupt	25
MIBSPI1	MIBSPI1 level 1 interrupt	26

Table 6-32. Interrupt Request Assignments (continued)

Modules	Interrupt Sources	Default VIM Interrupt Channel
LIN	LIN level 1 interrupt	27
MIBADC1	MIBADC1 sw group 2 interrupt	28
DCAN1	DCAN1 level 1 interrupt	29
SPI2	SPI2 level 1 interrupt	30
MIBADC1	MIBADC1 magnitude compare interrupt	31
FlexRay	FlexRay level 1 interrupt	32
DMA	FTCA interrupt	33
DMA	LFSA interrupt	34
DCAN2	DCAN2 level 0 interrupt	35
DMM	DMM level 0 interrupt	36
MIBSPI3	MIBSPI3 level 0 interrupt	37
MIBSPI3	MIBSPI3 level 1 interrupt	38
DMA	HBCA interrupt	39
DMA	BTCA interrupt	40
EMIF	AEMIFINT3	41
DCAN2	DCAN2 level 1 interrupt	42
DMM	DMM level 1 interrupt	43
DCAN1	DCAN1 IF3 interrupt	44
DCAN3	DCAN3 level 0 interrupt	45
DCAN2	DCAN2 IF3 interrupt	46
FPU	"OR" of the six Cortex R4F FPU Exceptions	47
FlexRay TU	FlexRay TU Transfer Status interrupt	48
SPI4	SPI4 level 0 interrupt	49
MIBADC2	MibADC2 event group interrupt	50
MIBADC2	MibADC2 sw group1 interrupt	51
FlexRay	FlexRay T0C interrupt	52
MIBSPI5	MIBSPI5 level 0 interrupt	53
SPI4	SPI4 level 1 interrupt	54
DCAN3	DCAN3 level 1 interrupt	55
MIBSPI5	MIBSPI5 level 1 interrupt	56
MIBADC2	MibADC2 sw group2 interrupt	57
FlexRay TU	FlexRay TU Error interrupt	58
MIBADC2	MibADC2 magnitude compare interrupt	59
DCAN3	DCAN3 IF3 interrupt	60
FMC	FSM_DONE interrupt	61
FlexRay	FlexRay T1C interrupt	62
N2HET2	N2HET2 level 0 interrupt	63
SCI	SCI level 0 interrupt	64
HET TU2	HET TU2 level 0 interrupt	65
I2C	I2C level 0 interrupt	66
Reserved	Reserved	67-72
N2HET2	N2HET2 level 1 interrupt	73
SCI	SCI level 1 interrupt	74
HET TU2	HET TU2 level 1 interrupt	75
Ethernet	C0_MISC_PULSE	76
Ethernet	C0_TX_PULSE	77
Ethernet	C0_THRESH_PULSE	78

Table 6-32. Interrupt Request Assignments (continued)

Modules	Interrupt Sources	Default VIM Interrupt Channel
Ethernet	C0_RX_PULSE	79
HWAG1	HWA_INT_REQ_H	80
HWAG2	HWA_INT_REQ_H	81
DCC1	DCC1 done interrupt	82
DCC2	DCC2 done interrupt	83
Reserved	Reserved	84
PBIST	PBIST_DONE	85
Reserved	Reserved	86
Reserved	Reserved	87
HWAG1	HWA_INT_REQ_L	88
HWAG2	HWA_INT_REQ_L	89
Reserved	Reserved	90-95

NOTE

Address location 0x00000000 in the VIM RAM is reserved for the phantom interrupt ISR entry; therefore only request channels 0..94 can be used and are offset by 1 address in the VIM RAM.

NOTE

The EMIF_nWAIT signal has a pull-up on it. The EMIF module generates a "Wait Rise" interrupt whenever it detects a rising edge on the EMIF_nWAIT signal. This interrupt condition is indicated as soon as the device is powered up. This can be ignored if the EMIF_nWAIT signal is not used in the application. If the EMIF_nWAIT signal is actually used in the application, then the external slave memory must always drive the EMIF_nWAIT signal such that an interrupt is not caused due to the default pull-up on this signal.

NOTE

The lower-order interrupt channels are higher priority channels than the higher-order interrupt channels.

NOTE

The application can change the mapping of interrupt sources to the interrupt channels via the interrupt channel control registers (CHANCTRLx) inside the VIM module.

6.16 DMA Controller

The DMA controller is used to transfer data between two locations in the memory map in the background of CPU operations. Typically, the DMA is used to:

- Transfer blocks of data between external and internal data memories
- Restructure portions of internal data memory
- Continually service a peripheral

6.16.1 DMA Features

- CPU independent data transfer
- One master port - PortB (64 bits wide) that interfaces to the TMS570 Memory System.
- FIFO buffer(4 entries deep and each 64bit wide)
- Channel control information is stored in RAM protected by parity
- 16 channels with individual enable
- Channel chaining capability
- 32 peripheral DMA requests
- Hardware and Software DMA requests
- 8, 16, 32 or 64-bit transactions supported
- Multiple addressing modes for source/destination (fixed, increment, offset)
- Auto-initiation
- Power-management mode
- Memory Protection with four configurable memory regions

6.16.2 Default DMA Request Map

The DMA module on this microcontroller has 16 channels and up to 32 hardware DMA requests. The module contains DREQASx registers which are used to map the DMA requests to the DMA channels. By default, channel 0 is mapped to request 0, channel 1 to request 1, and so on.

Some DMA requests have multiple sources, as shown in [Table 6-33](#). The application must ensure that only one of these DMA request sources is enabled at any time.

Table 6-33. DMA Request Line Connection

Modules	DMA Request Sources	DMA Request
MIBSPI1	MIBSPI1[1] ⁽¹⁾	DMAREQ[0]
MIBSPI1	MIBSPI1[0] ⁽²⁾	DMAREQ[1]
SPI2	SPI2 receive	DMAREQ[2]
SPI2	SPI2 transmit	DMAREQ[3]
MIBSPI1 / MIBSPI3 / DCAN2	MIBSPI1[2] / MIBSPI3[2] / DCAN2 IF3	DMAREQ[4]
MIBSPI1 / MIBSPI3 / DCAN2	MIBSPI1[3] / MIBSPI3[3] / DCAN2 IF2	DMAREQ[5]
DCAN1 / MIBSPI5	DCAN1 IF2 / MIBSPI5[2]	DMAREQ[6]
MIBADC1 / MIBSPI5	MIBADC1 event / MIBSPI5[3]	DMAREQ[7]
MIBSPI1 / MIBSPI3 / DCAN1	MIBSPI1[4] / MIBSPI3[4] / DCAN1 IF1	DMAREQ[8]
MIBSPI1 / MIBSPI3 / DCAN2	MIBSPI1[5] / MIBSPI3[5] / DCAN2 IF1	DMAREQ[9]
MIBADC1 / I2C / MIBSPI5	MIBADC1 G1 / I2C receive / MIBSPI5[4]	DMAREQ[10]
MIBADC1 / I2C / MIBSPI5	MIBADC1 G2 / I2C transmit / MIBSPI5[5]	DMAREQ[11]
RTI / MIBSPI1 / MIBSPI3	RTI DMAREQ0 / MIBSPI1[6] / MIBSPI3[6]	DMAREQ[12]
RTI / MIBSPI1 / MIBSPI3	RTI DMAREQ1 / MIBSPI1[7] / MIBSPI3[7]	DMAREQ[13]
MIBSPI3 / MibADC2 / MIBSPI5	MIBSPI3[1] ⁽¹⁾ / MibADC2 event / MIBSPI5[6]	DMAREQ[14]
MIBSPI3 / MIBSPI5	MIBSPI3[0] ⁽²⁾ / MIBSPI5[7]	DMAREQ[15]
MIBSPI1 / MIBSPI3 / DCAN1 / MibADC2	MIBSPI1[8] / MIBSPI3[8] / DCAN1 IF3 / MibADC2 G1	DMAREQ[16]
MIBSPI1 / MIBSPI3 / DCAN3 / MibADC2	MIBSPI1[9] / MIBSPI3[9] / DCAN3 IF1 / MibADC2 G2	DMAREQ[17]
RTI / MIBSPI5	RTI DMAREQ2 / MIBSPI5[8]	DMAREQ[18]
RTI / MIBSPI5	RTI DMAREQ3 / MIBSPI5[9]	DMAREQ[19]
N2HET1 / N2HET2 / DCAN3	N2HET1 DMAREQ[4] / N2HET2 DMAREQ[4] / DCAN3 IF2	DMAREQ[20]
N2HET1 / N2HET2 / DCAN3	N2HET1 DMAREQ[5] / N2HET2 DMAREQ[5] / DCAN3 IF3	DMAREQ[21]
MIBSPI1 / MIBSPI3 / MIBSPI5	MIBSPI1[10] / MIBSPI3[10] / MIBSPI5[10]	DMAREQ[22]
MIBSPI1 / MIBSPI3 / MIBSPI5	MIBSPI1[11] / MIBSPI3[11] / MIBSPI5[11]	DMAREQ[23]
N2HET1 / N2HET2 / SPI4 / MIBSPI5	N2HET1 DMAREQ[6] / N2HET2 DMAREQ[6] / SPI4 receive / MIBSPI5[12]	DMAREQ[24]
N2HET1 / N2HET2 / SPI4 / MIBSPI5	N2HET1 DMAREQ[7] / N2HET2 DMAREQ[7] / SPI4 transmit / MIBSPI5[13]	DMAREQ[25]
CRC / MIBSPI1 / MIBSPI3	CRC DMAREQ[0] / MIBSPI1[12] / MIBSPI3[12]	DMAREQ[26]
CRC / MIBSPI1 / MIBSPI3	CRC DMAREQ[1] / MIBSPI1[13] / MIBSPI3[13]	DMAREQ[27]
LIN / MIBSPI5	LIN receive / MIBSPI5[14]	DMAREQ[28]
LIN / MIBSPI5	LIN transmit / MIBSPI5[15]	DMAREQ[29]
MIBSPI1 / MIBSPI3 / SCI / MIBSPI5	MIBSPI1[14] / MIBSPI3[14] / SCI receive / MIBSPI5[1] ⁽¹⁾	DMAREQ[30]
MIBSPI1 / MIBSPI3 / SCI / MIBSPI5	MIBSPI1[15] / MIBSPI3[15] / SCI transmit / MIBSPI5[0] ⁽²⁾	DMAREQ[31]

(1) SPI1, SPI3, SPI5 receive in standard SPI mode

(2) SPI1, SPI3, SPI5 transmit in standard SPI mode

6.17 Real Time Interrupt Module

The real-time interrupt (RTI) module provides timer functionality for operating systems and for benchmarking code. The RTI module can incorporate several counters that define the timebases needed for scheduling an operating system.

The timers also allow you to benchmark certain areas of code by reading the values of the counters at the beginning and the end of the desired code range and calculating the difference between the values.

In addition the RTI provides a mechanism to synchronize the operating system to the FlexRay communication cycle. Clock supervision can detect issues on the FlexRay bus with an automatic switch to an internally generated timebase.

6.17.1 Features

The RTI module has the following features:

- Two independent 64 bit counter blocks
- Four configurable compares for generating operating system ticks or DMA requests. Each event can be driven by either counter block 0 or counter block 1.
- One counter block usable for application synchronization to FlexRay network including clock supervision
- Fast enabling/disabling of events
- Two time-stamp (capture) functions for system or peripheral interrupts, one for each counter block

6.17.2 Block Diagrams

Figure 6-17 shows a high-level block diagram for one of the two 64-bit counter blocks inside the RTI module. Both the counter blocks are identical except the Network Time Unit (NTUx) inputs are only available as time base inputs for the counter block 0.

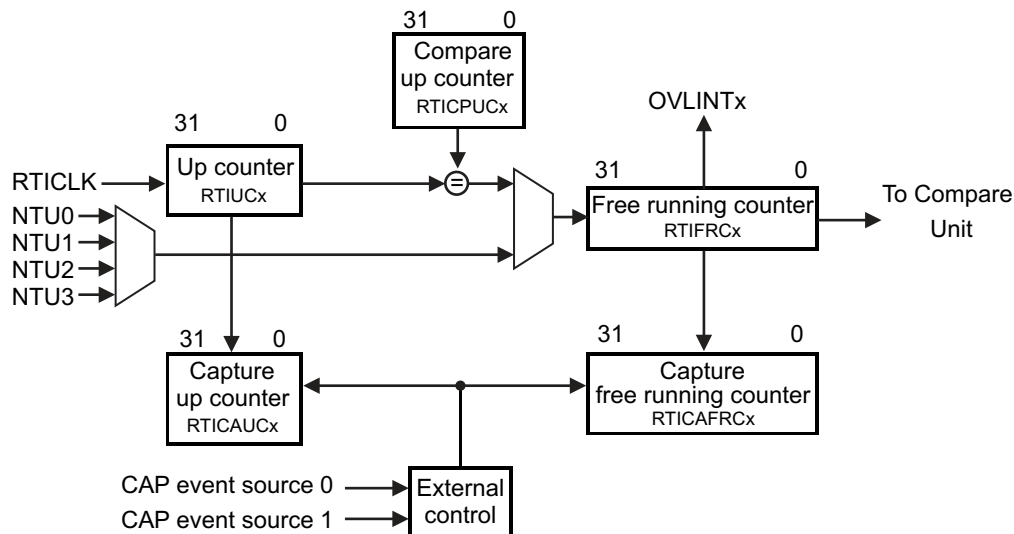

Figure 6-17. Counter Block Diagram

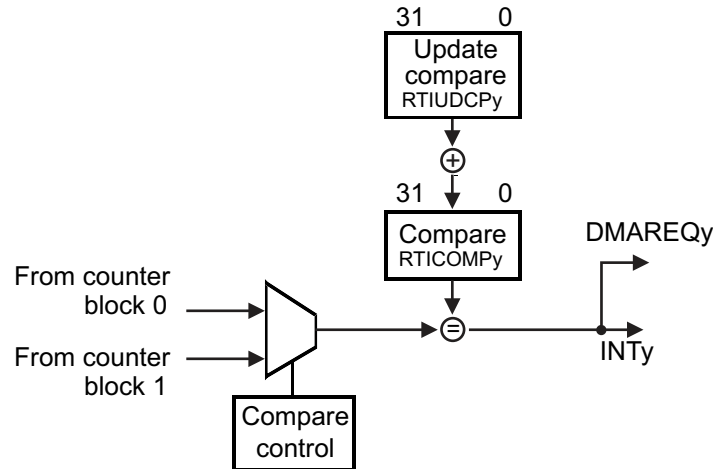

Figure 6-18. Compare Block Diagram

6.17.3 Clock Source Options

The RTI module uses the RTI1CLK clock domain for generating the RTI time bases.

The application can select the clock source for the RTI1CLK by configuring the RCLKSRC register in the System module at address 0xFFFFF50. The default source for RTI1CLK is VCLK.

For more information on clock sources refer to [Table 6-8](#) and [Table 6-13](#).

6.17.4 Network Time Synchronization Inputs

The RTI module supports 4 Network Time Unit (NTU) inputs that signal internal system events, and which can be used to synchronize the time base used by the RTI module. On this device, these NTU inputs are connected as shown below.

Table 6-34. Network Time Synchronization Inputs

NTU Input	Source
0	Macrotick
1	Start of Cycle
2	PLL2 Clock output
3	EXTCLKIN1 clock input

6.18 Error Signaling Module

The Error Signaling Module (ESM) manages the various error conditions on the TMS570 microcontroller. The error condition is handled based on a fixed severity level assigned to it. Any severe error condition can be configured to drive a low level on a dedicated device terminal called nERROR. This can be used as an indicator to an external monitor circuit to put the system into a safe state.

6.18.1 Features

The features of the Error Signaling Module are:

- 128 interrupt/error channels are supported, divided into 3 different groups
 - 64 channels with maskable interrupt and configurable error pin behavior
 - 32 error channels with non-maskable interrupt and predefined error pin behavior
 - 32 channels with predefined error pin behavior only
- Error pin to signal severe device failure
- Configurable timebase for error signal
- Error forcing capability

6.18.2 ESM Channel Assignments

The Error Signaling Module (ESM) integrates all the device error conditions and groups them in the order of severity. Group1 is used for errors of the lowest severity while Group3 is used for errors of the highest severity. The device response to each error is determined by the severity group it is connected to. [Table 6-36](#) shows the channel assignment for each group.

Table 6-35. ESM Groups

ERROR GROUP	INTERRUPT CHARACTERISTICS	INFLUENCE ON ERROR PIN
Group1	maskable, low or high priority	configurable
Group2	non-maskable, high priority	fixed
Group3	no interrupt generated	fixed

Table 6-36. ESM Channel Assignments

ERROR SOURCES	GROUP	CHANNELS
Reserved	Group1	0
MibADC2 - parity	Group1	1
DMA - MPU	Group1	2
DMA - parity	Group1	3
Reserved	Group1	4
DMA - imprecise read error	Group1	5
FMC - correctable error: bus1 and bus2 interfaces (does not include accesses to EEPROM bank)	Group1	6
N2HET1/N2HET2 - parity	Group1	7
HET TU1/HET TU2 - parity	Group1	8
HET TU1/HET TU2 - MPU	Group1	9
PLL - Slip	Group1	10
Clock Monitor - interrupt	Group1	11
FlexRay - parity	Group1	12
DMA - imprecise write error	Group1	13
FlexRay TU - parity	Group1	14
VIM RAM - parity	Group1	15
FlexRay TU - MPU	Group1	16
MibSPI1 - parity	Group1	17

Table 6-36. ESM Channel Assignments (continued)

ERROR SOURCES	GROUP	CHANNELS
MibSPI3 - parity	Group1	18
MibADC1 - parity	Group1	19
Reserved	Group1	20
DCAN1 - parity	Group1	21
DCAN3 - parity	Group1	22
DCAN2 - parity	Group1	23
MibSPI5 - parity	Group1	24
Reserved	Group1	25
RAM even bank (B0TCM) - correctable error	Group1	26
CPU - selftest	Group1	27
RAM odd bank (B1TCM) - correctable error	Group1	28
Reserved	Group1	29
DCC1 - error	Group1	30
CCM-R4 - selftest	Group1	31
Reserved	Group1	32
Reserved	Group1	33
Reserved	Group1	34
FMC - correctable error (EEPROM bank access)	Group1	35
FMC - uncorrectable error (EEPROM bank access)	Group1	36
IOMM - Mux configuration error	Group1	37
Power domain controller compare error	Group1	38
Power domain controller self-test error	Group1	39
eFuse Controller Error – this error signal is generated when any bit in the eFuse controller error status register is set. The application can choose to generate an interrupt whenever this bit is set to service any eFuse controller error conditions.	Group1	40
eFuse Controller - Self Test Error. This error signal is generated only when a self test on the eFuse controller generates an error condition. When an ECC self test error is detected, group 1 channel 40 error signal will also be set.	Group1	41
PLL2 - Slip	Group1	42
Ethernet Controller master interface	Group1	43
Reserved	Group1	44
Reserved	Group1	45
Reserved	Group1	46
Reserved	Group1	47
Reserved	Group1	48
Reserved	Group1	49
Reserved	Group1	50
Reserved	Group1	51
Reserved	Group1	52
Reserved	Group1	53
Reserved	Group1	54
Reserved	Group1	55
Reserved	Group1	56
Reserved	Group1	57
Reserved	Group1	58
Reserved	Group1	59
Reserved	Group1	60
Reserved	Group1	61

Table 6-36. ESM Channel Assignments (continued)

ERROR SOURCES	GROUP	CHANNELS
DCC2 - error	Group1	62
Reserved	Group1	63
GROUP 2		
Reserved	Group2	0
Reserved	Group2	1
CCMR4 - compare	Group2	2
Reserved	Group2	3
FMC - uncorrectable error (address parity on bus1 accesses)	Group2	4
Reserved	Group2	5
RAM even bank (B0TCM) - uncorrectable error	Group2	6
Reserved	Group2	7
RAM odd bank (B1TCM) - uncorrectable error	Group2	8
Reserved	Group2	9
RAM even bank (B0TCM) - address bus parity error	Group2	10
Reserved	Group2	11
RAM odd bank (B1TCM) - address bus parity error	Group2	12
Reserved	Group2	13
Reserved	Group2	14
Reserved	Group2	15
TCM - ECC live lock detect	Group2	16
Reserved	Group2	17
Reserved	Group2	18
Reserved	Group2	19
Reserved	Group2	20
Reserved	Group2	21
Reserved	Group2	22
Reserved	Group2	23
RTI_WWD_NMI	Group2	24
Reserved	Group2	25
Reserved	Group2	26
Reserved	Group2	27
Reserved	Group2	28
Reserved	Group2	29
Reserved	Group2	30
Reserved	Group2	31
GROUP 3		
Reserved	Group3	0
eFuse Controller - autoload error	Group3	1
Reserved	Group3	2
RAM even bank (B0TCM) - ECC uncorrectable error	Group3	3
Reserved	Group3	4
RAM odd bank (B1TCM) - ECC uncorrectable error	Group3	5
Reserved	Group3	6
FMC - uncorrectable error: bus1 and bus2 interfaces (does not include address parity error and errors on accesses to EEPROM bank)	Group3	7
Reserved	Group3	8
Reserved	Group3	9
Reserved	Group3	10

Table 6-36. ESM Channel Assignments (continued)

ERROR SOURCES	GROUP	CHANNELS
Reserved	Group3	11
Reserved	Group3	12
Reserved	Group3	13
Reserved	Group3	14
Reserved	Group3	15
Reserved	Group3	16
Reserved	Group3	17
Reserved	Group3	18
Reserved	Group3	19
Reserved	Group3	20
Reserved	Group3	21
Reserved	Group3	22
Reserved	Group3	23
Reserved	Group3	24
Reserved	Group3	25
Reserved	Group3	26
Reserved	Group3	27
Reserved	Group3	28
Reserved	Group3	29
Reserved	Group3	30
Reserved	Group3	31

6.19 Reset / Abort / Error Sources

Table 6-37. Reset/Abort/Error Sources

ERROR SOURCE	SYSTEM MODE	ERROR RESPONSE	ESM HOOKUP group.channel
CPU TRANSACTIONS			
Precise write error (NCNB/Strongly Ordered)	User/Privilege	Precise Abort (CPU)	n/a
Precise read error (NCB/Device or Normal)	User/Privilege	Precise Abort (CPU)	n/a
Imprecise write error (NCB/Device or Normal)	User/Privilege	Imprecise Abort (CPU)	n/a
Illegal instruction	User/Privilege	Undefined Instruction Trap (CPU) ⁽¹⁾	n/a
MPU access violation	User/Privilege	Abort (CPU)	n/a
SRAM			
B0 TCM (even) ECC single error (correctable)	User/Privilege	ESM	1.26
B0 TCM (even) ECC double error (non-correctable)	User/Privilege	Abort (CPU), ESM => nERROR	3.3
B0 TCM (even) uncorrectable error (i.e. redundant address decode)	User/Privilege	ESM => NMI => nERROR	2.6
B0 TCM (even) address bus parity error	User/Privilege	ESM => NMI => nERROR	2.10
B1 TCM (odd) ECC single error (correctable)	User/Privilege	ESM	1.28
B1 TCM (odd) ECC double error (non-correctable)	User/Privilege	Abort (CPU), ESM => nERROR	3.5
B1 TCM (odd) uncorrectable error (i.e. redundant address decode)	User/Privilege	ESM => NMI => nERROR	2.8
B1 TCM (odd) address bus parity error	User/Privilege	ESM => NMI => nERROR	2.12
FLASH			
FMC correctable error - Bus1 and Bus2 interfaces (does not include accesses to EEPROM bank)	User/Privilege	ESM	1.6
FMC uncorrectable error - Bus1 accesses (does not include address parity error)	User/Privilege	Abort (CPU), ESM => nERROR	3.7
FMC uncorrectable error - Bus2 accesses (does not include address parity error and EEPROM bank accesses)	User/Privilege	ESM => nERROR	3.7
FMC uncorrectable error - address parity error on Bus1 accesses	User/Privilege	ESM => NMI => nERROR	2.4
FMC correctable error - Accesses to EEPROM bank	User/Privilege	ESM	1.35
FMC uncorrectable error - Accesses to EEPROM bank	User/Privilege	ESM	1.36
DMA TRANSACTIONS			
External imprecise error on read (Illegal transaction with ok response)	User/Privilege	ESM	1.5
External imprecise error on write (Illegal transaction with ok response)	User/Privilege	ESM	1.13
Memory access permission violation	User/Privilege	ESM	1.2
Memory parity error	User/Privilege	ESM	1.3
DMM TRANSACTIONS			
External imprecise error on read (Illegal transaction with ok response)	User/Privilege	ESM	1.5
External imprecise error on write (Illegal transaction with ok response)	User/Privilege	ESM	1.13
HET TU1 (HTU1)			
NCNB (Strongly Ordered) transaction with slave error response	User/Privilege	Interrupt => VIM	n/a
External imprecise error (Illegal transaction with ok response)	User/Privilege	Interrupt => VIM	n/a
Memory access permission violation	User/Privilege	ESM	1.9

(1) The Undefined Instruction TRAP is NOT detectable outside the CPU. The trap is taken only if the instruction reaches the execute stage of the CPU.

Table 6-37. Reset/Abort/Error Sources (continued)

ERROR SOURCE	SYSTEM MODE	ERROR RESPONSE	ESM HOOKUP group.channel
Memory parity error	User/Privilege	ESM	1.8
HET TU2 (HTU2)			
NCNB (Strongly Ordered) transaction with slave error response	User/Privilege	Interrupt => VIM	n/a
External imprecise error (Illegal transaction with ok response)	User/Privilege	Interrupt => VIM	n/a
Memory access permission violation	User/Privilege	ESM	1.9
Memory parity error	User/Privilege	ESM	1.8
N2HET1			
Memory parity error	User/Privilege	ESM	1.7
N2HET2			
Memory parity error	User/Privilege	ESM	1.7
FLEXRAY			
Memory parity error	User/Privilege	ESM	1.12
FLEXRAY TU			
NCNB (Strongly Ordered) transaction with slave error response	User/Privilege	Interrupt => VIM	n/a
External imprecise error (Illegal transaction with ok response)	User/Privilege	Interrupt => VIM	n/a
Memory access permission violation	User/Privilege	ESM	1.16
Memory parity error	User/Privilege	ESM	1.14
ETHERNET MASTER INTERFACE			
Any error reported by slave being accessed	User/Privilege	ESM	1.43
MIBSPI			
MibSPI1 memory parity error	User/Privilege	ESM	1.17
MibSPI3 memory parity error	User/Privilege	ESM	1.18
MibSPI5 memory parity error	User/Privilege	ESM	1.24
MIBADC			
MibADC1 Memory parity error	User/Privilege	ESM	1.19
MibADC2 Memory parity error	User/Privilege	ESM	1.1
DCAN			
DCAN1 memory parity error	User/Privilege	ESM	1.21
DCAN2 memory parity error	User/Privilege	ESM	1.23
DCAN3 memory parity error	User/Privilege	ESM	1.22
PLL			
PLL slip error	User/Privilege	ESM	1.10
PLL #2 slip error	User/Privilege	ESM	1.42
CLOCK MONITOR			
Clock monitor interrupt	User/Privilege	ESM	1.11
DCC			
DCC1 error	User/Privilege	ESM	1.30
DCC2 error	User/Privilege	ESM	1.62
CCM-R4			
Self test failure	User/Privilege	ESM	1.31
Compare failure	User/Privilege	ESM => NMI => nERROR	2.2
VIM			
Memory parity error	User/Privilege	ESM	1.15
VOLTAGE MONITOR			
VMON out of voltage range	n/a	Reset	n/a
CPU SELFTEST (LBIST)			
CPU Selftest (LBIST) error	User/Privilege	ESM	1.27

Table 6-37. Reset/Abort/Error Sources (continued)

ERROR SOURCE	SYSTEM MODE	ERROR RESPONSE	ESM HOOKUP group.channel
PIN MULTIPLEXING CONTROL			
Mux configuration error	User/Privilege	ESM	1.37
POWER DOMAIN CONTROL			
PSCON compare error	User/Privilege	ESM	1.38
PSCON self-test error	User/Privilege	ESM	1.39
eFuse Controller			
eFuse Controller Autoload error	User/Privilege	ESM => nERROR	3.1
eFuse Controller - Any bit set in the error status register	User/Privilege	ESM	1.40
eFuse Controller self-test error	User/Privilege	ESM	1.41
WINDOWED WATCHDOG			
WWD Non-Maskable Interrupt exception	n/a	ESM => NMI => nERROR	2.24
ERRORS REFLECTED IN THE SYSESR REGISTER			
Power-Up Reset	n/a	Reset	n/a
Oscillator fail / PLL slip ⁽²⁾	n/a	Reset	n/a
Watchdog exception	n/a	Reset	n/a
CPU Reset (driven by the CPU STC)	n/a	Reset	n/a
Software Reset	n/a	Reset	n/a
External Reset	n/a	Reset	n/a

(2) Oscillator fail/PLL slip can be configured in the system register (SYS.PLLCTL1) to generate a reset.

6.20 Digital Windowed Watchdog

This device includes a digital windowed watchdog (DWWD) module that protects against runaway code execution.

The DWWD module allows the application to configure the time window within which the DWWD module expects the application to service the watchdog. A watchdog violation occurs if the application services the watchdog outside of this window, or fails to service the watchdog at all. The application can choose to generate a system reset or a non-maskable interrupt to the CPU in case of a watchdog violation.

The watchdog is disabled by default and must be enabled by the application. Once enabled, the watchdog can only be disabled upon a system reset.

6.21 Debug Subsystem

6.21.1 Block Diagram

The device contains an ICEPICK module to allow JTAG access to the scan chains.

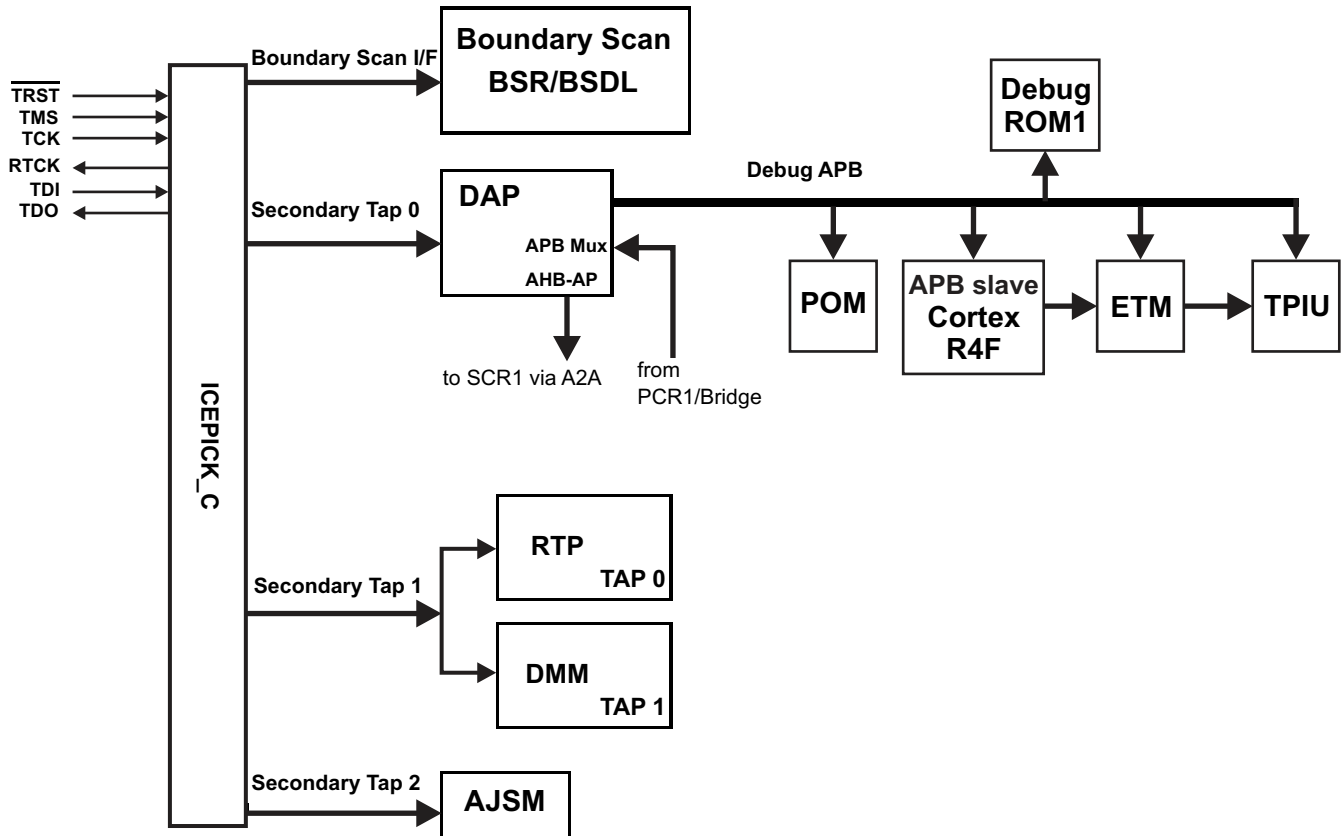

Figure 6-19. Debug Subsystem Block Diagram

6.21.2 Debug Components Memory Map

Table 6-38. Debug Components Memory Map

MODULE NAME	FRAME CHIP SELECT	FRAME ADDRESS RANGE		FRAME SIZE	ACTUAL SIZE	RESPONSE FOR ACCESS TO UNIMPLEMENTED LOCATIONS IN FRAME
		START	END			
CoreSight Debug ROM	CSCS0	0xFFA0_0000	0xFFA0_0FFF	4KB	4KB	Reads: 0, writes: no effect
Cortex-R4F Debug	CSCS1	0xFFA0_1000	0xFFA0_1FFF	4KB	4KB	Reads: 0, writes: no effect
ETM-R4	CSCS2	0xFFA0_2000	0xFFA0_2FFF	4KB	4KB	Reads: 0, writes: no effect
CoreSight TPIU	CSCS3	0xFFA0_3000	0xFFA0_3FFF	4KB	4KB	Reads: 0, writes: no effect

6.21.3 JTAG Identification Code

The JTAG ID code for this device is the same as the device ICEPick Identification Code.

JTAG ID Code

Silicon Revision	ID
Rev A	0x0D8A002F

JTAG ID Code (continued)

Silicon Revision	ID
Rev B	0x2D8A002F
Rev C	0x3D8A002F

6.21.4 Debug ROM

The Debug ROM stores the location of the components on the Debug APB bus:

Table 6-39. Debug ROM table

ADDRESS	DESCRIPTION	VALUE
0x000	pointer to Cortex-R4F	0x0000 1003
0x001	ETM-R4	0x0000 2003
0x002	TPIU	0x0000 3003
0x003	POM	0x0000 4003
0x004	end of table	0x0000 0000

6.21.5 JTAG Scan Interface Timings

Table 6-40. JTAG Scan Interface Timing⁽¹⁾

NO.		MIN	MAX	UNIT
	f_{TCK}	TCK frequency (at HCLKmax)		MHz
	f_{RTCK}	RTCK frequency (at TCKmax and HCLKmax)		MHz
1	$t_{d(TCK-RTCK)}$		24	ns
2	$t_{su(TDI/TMS-RTCKr)}$	26		ns
3	$t_{h(RTCKr-TDI/TMS)}$	0		ns
4	$t_{h(RTCKr-TDO)}$	0		ns
5	$t_{d(TCKf-TDO)}$		12	ns

(1) Timings for TDO are specified for a maximum of 50pF load on TDO

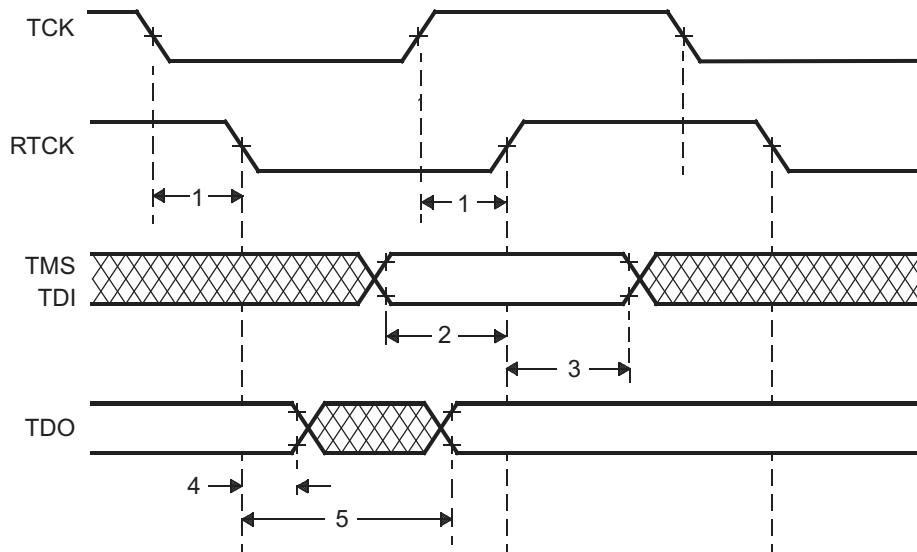

Figure 6-20. JTAG Timing

6.21.6 Advanced JTAG Security Module

This device includes an Advanced JTAG Security Module (AJSM), which provides maximum security to the device's memory content by allowing users to secure the device after programming.

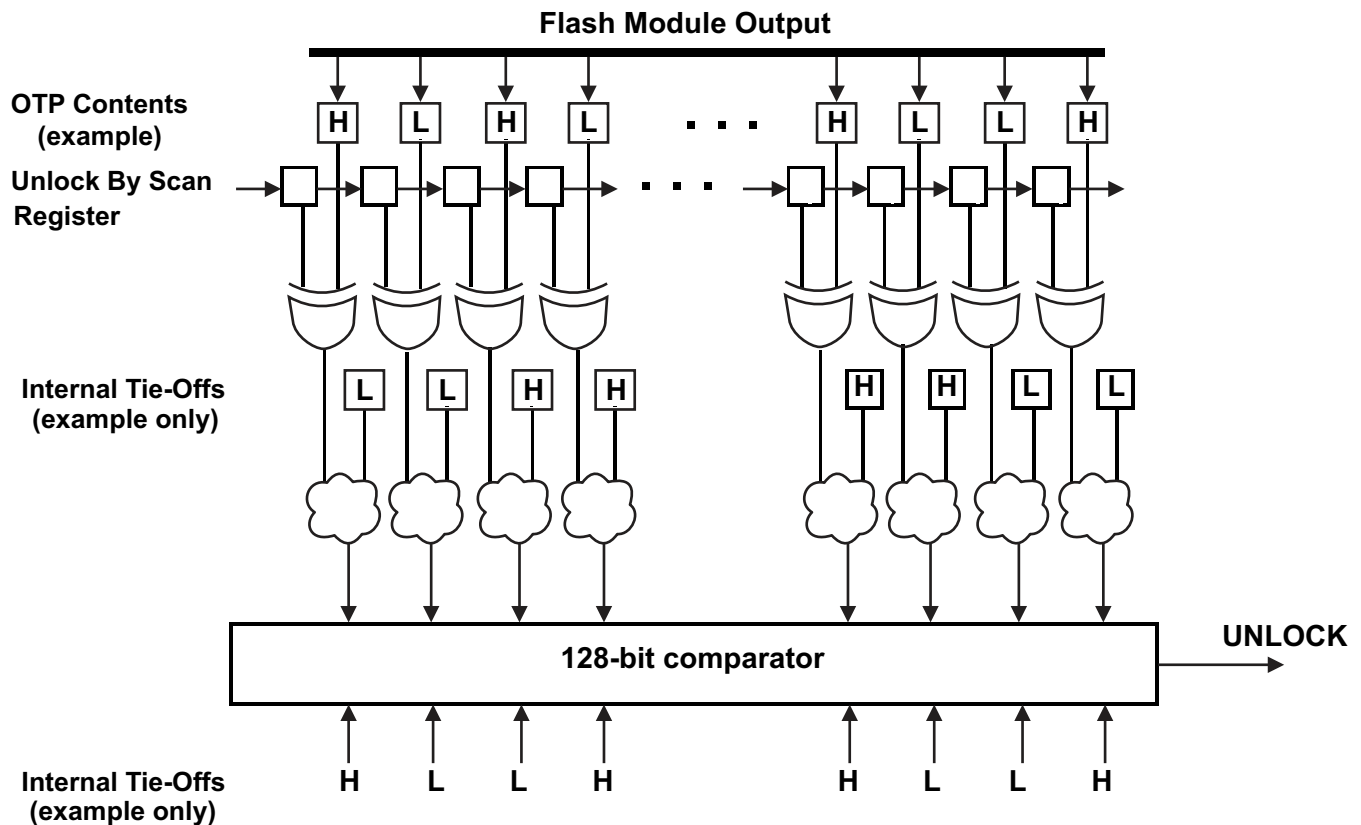

Figure 6-21. AJSM Unlock

The device is unsecure by default by virtue of a 128-bit visible unlock code programmed in the OTP address 0xF0000000. The OTP contents are XOR-ed with the "Unlock By Scan" register contents. The outputs of these XOR gates are again combined with a set of secret internal tie-offs. The output of this combinational logic is compared against a secret hard-wired 128-bit value. A match results in the UNLOCK signal being asserted, so that the device is now unsecure.

A user can secure the device by changing at least one bit in the visible unlock code from 1 to 0. Changing a 0 to 1 is not possible since the visible unlock code is stored in the One Time Programmable (OTP) flash region. Also, changing all the 128 bits to zeros is not a valid condition and will permanently secure the device.

Once secured, a user can unsecure the device by scanning an appropriate value into the "Unlock By Scan" register of the AJSM module. The value to be scanned is such that the XOR of the OTP contents and the Unlock-By-Scan register contents results in the original visible unlock code.

The Unlock-By-Scan register is reset only upon asserting power-on reset (nPORRST).

A secure device only permits JTAG accesses to the AJSM scan chain via the Secondary Tap 2 of the ICEPick module. All other secondary taps, test taps and the boundary scan interface are not accessible in this state.

6.21.7 Embedded Trace Macrocell (ETM-R4)

The device contains a ETM-R4 module with a 32-bit internal data port. The ETM-R4 module is connected to a TPIU with a 32-bit data bus; the TPIU provides a 35-bit (32-bit data, 3-bit control) external interface for trace. The ETM-R4 is CoreSight compliant and follows the ETM v3 specification; for more details see ARM CoreSight ETM-R4 TRM specification.

6.21.7.1 ETM TRACECLKIN Selection

The ETM clock source can be selected as either VCLK or the external ETMTRACECLKIN pin. The selection is done by the EXTCTRL0UT[1:0] control bits of the TPIU; the default is '00'. The address of this register is TPIU base address + 0x404.

Before you begin accessing TPIU registers, TPIU should be unlocked via coresight key and 1 or 2 should be written to this register.

Table 6-41. TPIU / TRACECLKIN Selection

EXTCTRL0UT[1:0]	TPIU/TRACECLKIN
00	tied-zero
01	VCLK
10	ETMTRACECLKIN
11	tied-zero

6.21.7.2 Timing Specifications

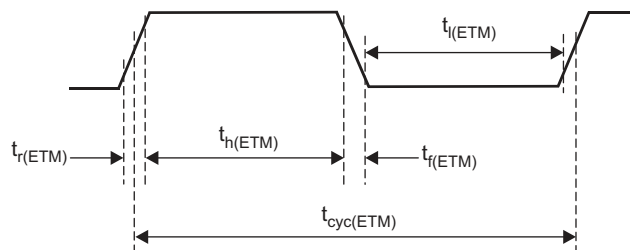

Figure 6-22. ETMTRACECLKOUT Timing

Table 6-42. ETMTRACECLK Timing

		MIN	MAX	UNIT
$t_{cyc(ETM)}$	Clock period	$t_{(HCLK)} \times 4$		
$t_l(ETM)$	Low pulse width	20		ns
$t_h(ETM)$	High pulse width	20		ns
$t_r(ETM)$	Clock and data rise time		3	ns
$t_f(ETM)$	Clock and data fall time		3	ns

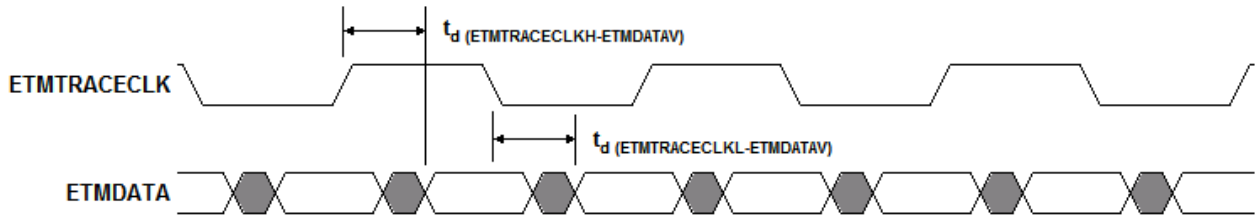

Figure 6-23. ETMDATA Timing

Table 6-43. ETMDATA Timing

		TMS5703137CGWTQEP		TMS5703137CGWTMEP		UNIT
		MIN	MAX	MIN	MAX	
$t_{d(ETMTRACECLKH-ETMDATAV)}$	Delay time from ETM trace clock high to ETM data valid	1.5	7	1.3	7	ns
$t_{d(ETMTRACECLKL-ETMDATAV)}$	Delay time from ETM trace clock low to ETM data valid	1.5	7	1.3	7	

NOTE

The ETMTRACECLK and ETMDATA timing is based on a 15pF load and for ambient temperature lower than 85°C.

6.21.8 RAM Trace Port (RTP)

The RTP provides the ability to datalog the RAM contents of the devices or accesses to peripherals without program intrusion. It can trace all data write or read accesses to internal RAM. In addition, it provides the capability to directly transfer data to a FIFO to support a CPU-controlled transmission of the data. The trace data is transmitted over a dedicated external interface.

6.21.8.1 Features

The RTP offers the following features:

- Two modes of operation - Trace Mode and Direct Data Mode
 - Trace Mode
 - Non-intrusive data trace on write or read operation
 - Visibility of RAM content at any time on external capture hardware
 - Trace of peripheral accesses
 - Two configurable trace regions for each RAM module to limit amount of data to be traced
 - FIFO to store data and address of data of multiple read/write operations
 - Trace of CPU and/or DMA accesses with indication of the master in the transmitted data packet
 - Direct Data Mode
 - Directly write data with the CPU or trace read operations to a FIFO, without transmitting header and address information
- Dedicated synchronous interface to transmit data to external devices
- Free-running clock generation or clock stop mode between transmissions
- Up to 100 Mbit per sec/pin transfer rate for transmitting data
- Pins not used in functional mode can be used as GIOs

6.21.8.2 Timing Specifications

Table 6-44. RTPCLK Timing

			MIN	UNIT
$t_{cyc(RTP)}$	Clock period, prescaled from HCLK; must not be faster than HCLK / 2	-40°C to 125°C	11 (90 MHz)	ns
$t_h(RTP)$	High pulse width	-40°C to 125°C	$((t_{cyc(RTP)}) / 2) - ((t_r + t_f) / 2)$	
$t_l(RTP)$	Low pulse width	-40°C to 125°C	$((t_{cyc(RTP)}) / 2) - ((t_r + t_f) / 2)$	

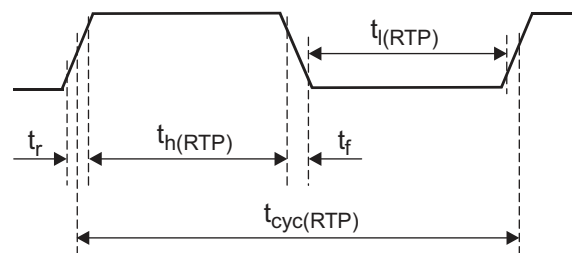

Figure 6-24. RTPCLK Timing

Table 6-45. RTPDATA Timing

		MIN	MAX	UNIT
$t_d(RTPCLKH-RTPSYNCV)$	SYNC delay time	-5	4	ns
$t_d(RTPCLKH-RTPDATAV)$	Data delay time	-5	4	

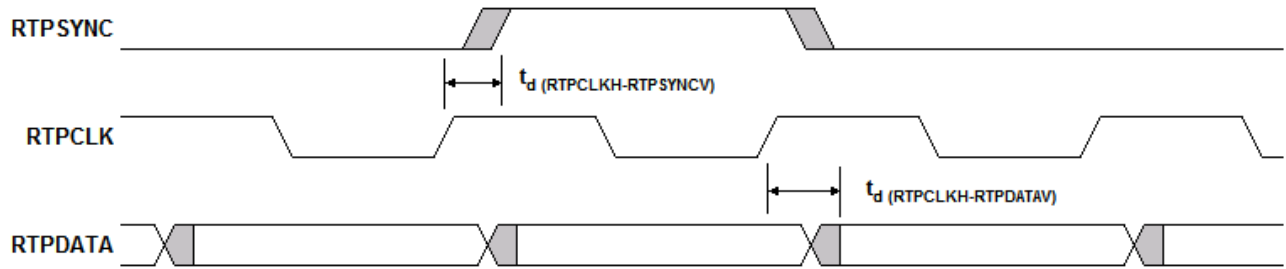

Figure 6-25. RTPDATA Timing

Table 6-46. RTPnENA Timing

		MIN	MAX	UNIT
$t_{dis(RTP)}$	Time RTPnENA must go high before what would be the next RTPSYNC, to ensure delaying the next packet	$3t_{c(HCLK)} + t_r(RTPSYNC) + 12 \text{ ns}$		
$t_{ena(RTP)}$	Time after RTPnENA goes low before a packet that has been halted, resumes	$4t_{c(HCLK)} + t_r(RTPSYNC)$	$5t_{c(HCLK)} + t_r(RTPSYNC) + 12 \text{ ns}$	

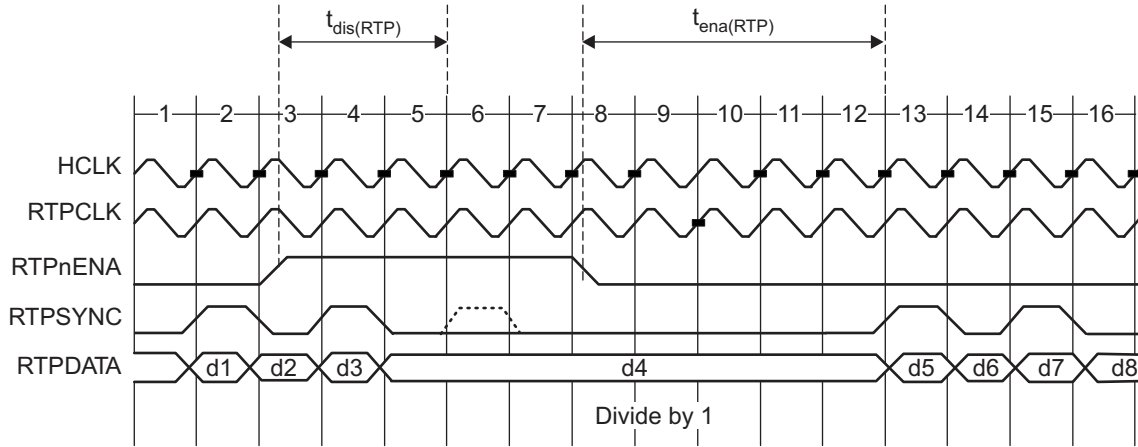

Figure 6-26. RTPnENA Timing

6.21.9 Data Modification Module (DMM)

The DMM provides the capability to modify data in the entire 4 GB address space of the devices from an external peripheral, with minimal interruption of the application.

6.21.9.1 Features

The DMM module has the following features:

- Acts as a bus master, thus enabling direct writes to the 4GB address space without CPU intervention
- Writes to memory locations specified in the received packet (leverages packets defined by trace mode of the RAM trace port (RTP) module)
- Writes received data to consecutive addresses, which are specified by the DMM module (leverages packets defined by direct data mode of RTP module)
- Configurable port width (1, 2, 4, 8, 16 pins)
- Up to 100 Mbit/s pin data rate
- Unused pins configurable as GPIO pins

6.21.9.2 Timing Specifications

Table 6-47. DMMCLK Timing

			MIN	UNIT
$t_{cyc(DMM)}$	Clock period		$t_{c(HCLK)} \times 2$	
$t_{h(DMM)}$	High pulse width	-40°C to 125°C	$((t_{cyc(DMM)}) / 2) - ((t_r + t_f) / 2)$	
$t_{l(DMM)}$	Low pulse width	-40°C to 125°C	$((t_{cyc(DMM)}) / 2) - ((t_r + t_f) / 2)$	

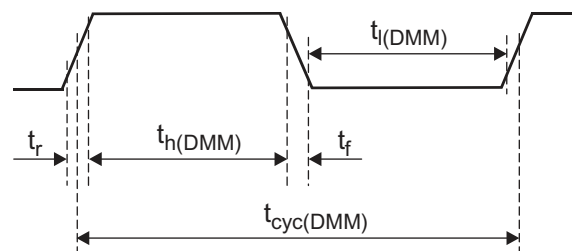

Figure 6-27. DMMCLK Timing

Table 6-48. DMMDATA Timing

PARAMETER		MIN	UNIT
$t_{ssu(DMM)}$	SYNC active to clk falling edge setup time	2 ns	ns
$t_{sh(DMM)}$	clk falling edge to SYNC deactive hold time	3 ns	
$t_{dsu(DMM)}$	DATA to clk falling edge setup time	2 ns	
$t_{dh(DMM)}$	clk falling edge to DATA hold time	3 ns	

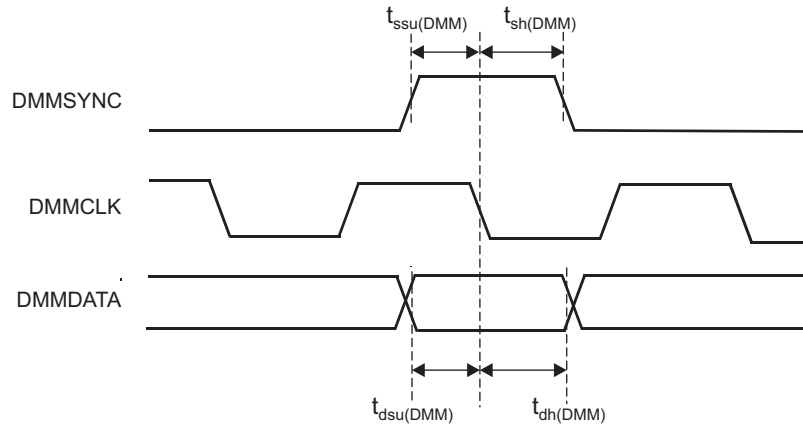

Figure 6-28. DMMDATA Timing

Figure 6-29 shows a case with 1 DMM packet per 2 DMMCLK cycles (Mode = Direct Data Mode, data width = 8, portwidth = 4) where none of the packets received by the DMM are sent out, leading to filling up of the internal buffers. The DMMnENA signal is shown asserted, after the first two packets have been received and synchronised to the HCLK domain. Here, the DMM has the capacity to accept packets D4x, D5x, D6x, D7x. Packet D8 would result in an overflow. Once DMMnENA is asserted, the DMM expects to stop receiving packets after 4 HCLK cycles; once DMMnENA is de-asserted, the DMM can handle packets immediately (after 0 HCLK cycles).

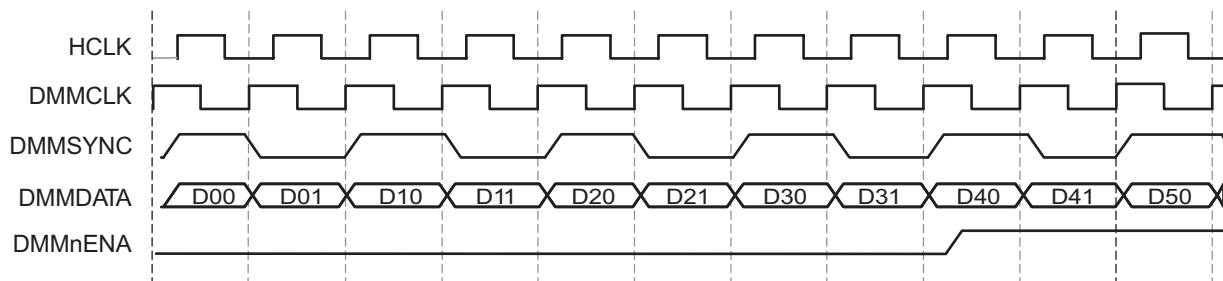

Figure 6-29. DMMnENA Timing

6.21.10 Boundary Scan Chain

The device supports IEEE1149.1-compliant boundary scan for testing pin-to-pin compatibility. The boundary scan chain is connected to the Boundary Scan Interface of the ICEPICK module.

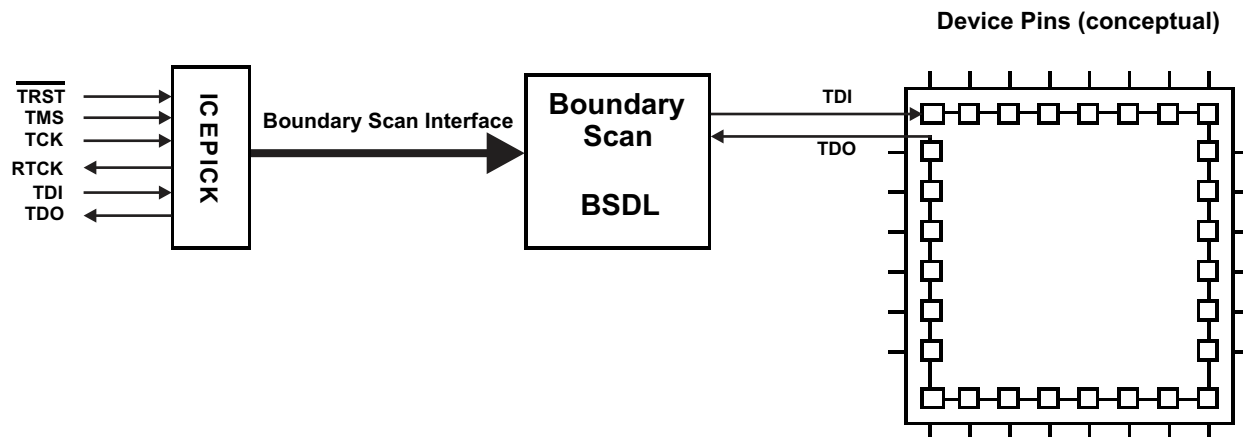

Figure 6-30. Boundary Scan Implementation (Conceptual Diagram)

Data is serially shifted into all boundary-scan buffers via TDI, and out via TDO.

7 Peripheral Information

7.1 Peripheral Legend

Table 7-1. Peripheral Legend

Abbreviation	Full Name
MibADC	Analog To Digital Converter
CCM-R4F	CPU Compare Module - CortexR4F
CRC	Cyclic Redundancy Check
DCAN	Controller Area Network
DCC	Dual Clock Comparator
DMA	Direct Memory Access
DMM	Data Modification Module
EMIF	External Memory Interface
ESM	Error Signaling Module
ETM-R4F	Embedded Trace Macrocell - CortexR4F
FTU	FlexRay Transfer Unit
GPIO	General-Purpose Input/Output
HTU	High End Timer Transfer Unit
I2C	Inter-Integrated Circuit
LIN	Local Interconnect Network
MIBSPI	Multibuffer Serial Peripheral Interface
N2HET	Platform High-End Timer
POM	Parameter Overlay Module
RTI	Real-Time Interrupt Module
RTP	RAM Trace Port
SCI	Serial Communications Interface
SPI	Serial Peripheral Interface
VIM	Vectored Interrupt Manager

7.2 Multi-Buffered 12bit Analog-to-Digital Converter

The multibuffered A-to-D converter (MibADC) has a separate power bus for its analog circuitry that enhances the A-to-D performance by preventing digital switching noise on the logic circuitry which could be present on V_{SS} and V_{CC} from coupling into the A-to-D analog stage. All A-to-D specifications are given with respect to AD_{REFLO} unless otherwise noted.

Table 7-2. MibADC Overview

Description	Value
Resolution	12 bits
Monotonic	Assured
Output conversion code	00h to FFFh [00 for $V_{AI} \leq AD_{REFLO}$; FFF for $V_{AI} \geq AD_{REFHI}$]

7.2.1 Features

- 10-/12-bit resolution
- AD_{REFHI} and AD_{REFLO} pins (high and low reference voltages)
- Total Sample/Hold/Convert time: 600ns Typical Minimum at 30MHz ADCLK
- One memory region per conversion group is available (event, group 1, group 2)
- Allocation of channels to conversion groups is completely programmable
- Memory regions are serviced either by interrupt or by DMA

- Programmable interrupt threshold counter is available for each group
- Programmable magnitude threshold interrupt for each group for any one channel
- Option to read either 8-bit, 10-bit or 12-bit values from memory regions
- Single or continuous conversion modes
- Embedded self-test
- Embedded calibration logic
- Enhanced power-down mode
 - Optional feature to automatically power down ADC core when no conversion is in progress
- External event pin (ADEVT) programmable as general-purpose I/O

7.2.2 Event Trigger Options

The ADC module supports 3 conversion groups: Event Group, Group1 and Group2. Each of these 3 groups can be configured to be hardware event-triggered. In that case, the application can select from among 8 event sources to be the trigger for a group's conversions.

7.2.2.1 Default MIBADC1 Event Trigger Hookup

Table 7-3. MIBADC1 Event Trigger Hookup

Event Number	Source Select Bits For G1, G2 Or Event (G1SRC[2:0], G2SRC[2:0] or EVSRC[2:0])	Trigger
1	000	ADEVT
2	001	N2HET1[8]
3	010	N2HET1[10]
4	011	RTI compare 0 interrupt
5	100	N2HET1[12]
6	101	N2HET1[14]
7	110	GIOB[0]
8	111	GIOB[1]

NOTE

For ADEVT, N2HET1 and GIOB trigger sources, the connection to the MibADC1 module trigger input is made from the output side of the input buffer. This way, a trigger condition can be generated either by configuring the function as output onto the pad (via the mux control), or by driving the function from an external trigger source as input. If the mux control module is used to select different functionality instead of the ADEVT, N2HET1[x] or GIOB[x] signals, then care must be taken to disable these signals from triggering conversions; there is no multiplexing on the input connections.

NOTE

For the RTI compare 0 interrupt source, the connection is made directly from the output of the RTI module. That is, the interrupt condition can be used as a trigger source even if the actual interrupt is not signaled to the CPU.

7.2.2.2 Alternate MIBADC1 Event Trigger Hookup

Table 7-4. Alternate MIBADC1 Event Trigger Hookup

Event Number	Source Select Bits for G1, G2 or Event (G1SRC[2:0], G2SRC[2:0] or EVSRC[2:0])	Trigger
1	000	ADEVT
2	001	N2HET2[5]

Table 7-4. Alternate MIBADC1 Event Trigger Hookup (continued)

Event Number	Source Select Bits for G1, G2 or Event (G1SRC[2:0], G2SRC[2:0] or EVSRC[2:0])	Trigger
3	010	N2HET1[27]
4	011	RTI compare 0 interrupt
5	100	N2HET1[17]
6	101	N2HET1[19]
7	110	N2HET1[11]
8	111	N2HET2[13]

The selection between the default MIBADC1 event trigger hook-up versus the alternate event trigger hook-up is done by multiplexing control module register 30 bits 0 and 1.

If 30[0] = 1, then the default MibADC1 event trigger hook-up is used.

If 30[0] = 0 and 30[1] = 1, then the alternate MibADC1 event trigger hook-up is used.

NOTE

For ADEVT trigger source, the connection to the MibADC1 module trigger input is made from the output side of the input buffer. This way, a trigger condition can be generated either by configuring ADEVT as an output function on to the pad (via the mux control), or by driving the ADEVT signal from an external trigger source as input. If the mux control module is used to select different functionality instead of the ADEVT signal, then care must be taken to disable ADEVT from triggering conversions; there is no multiplexing on the input connection.

NOTE

For N2HETx trigger sources, the connection to the MibADC1 module trigger input is made from the input side of the output buffer (at the N2HETx module boundary). This way, a trigger condition can be generated even if the N2HETx signal is not selected to be output on the pad.

NOTE

For the RTI compare 0 interrupt source, the connection is made directly from the output of the RTI module. That is, the interrupt condition can be used as a trigger source even if the actual interrupt is not signaled to the CPU.

7.2.2.3 Default MIBADC2 Event Trigger Hookup

Table 7-5. MIBADC2 Event Trigger Hookup

Event Number	Source Select Bits for G1, G2 or Event (G1SRC[2:0], G2SRC[2:0] or EVSRC[2:0])	Trigger
1	000	AD2EVT
2	001	N2HET1[8]
3	010	N2HET1[10]
4	011	RTI compare 0
5	100	N2HET1[12]
6	101	N2HET1[14]
7	110	GI0B[0]
8	111	GI0B[1]

NOTE

For AD2EVT, N2HET1 and GIOB trigger sources, the connection to the MibADC2 module trigger input is made from the output side of the input buffer. This way, a trigger condition can be generated either by configuring the function as output onto the pad (via the mux control), or by driving the function from an external trigger source as input. If the mux control module is used to select different functionality instead of the AD2EVT, N2HET1[x] or GIOB[x] signals, then care must be taken to disable these signals from triggering conversions; there is no multiplexing on the input connections.

NOTE

For the RTI compare 0 interrupt source, the connection is made directly from the output of the RTI module. That is, the interrupt condition can be used as a trigger source even if the actual interrupt is not signaled to the CPU.

7.2.2.4 Alternate MIBADC2 Event Trigger Hookup**Table 7-6. Alternate MIBADC2 Event Trigger Hookup**

Event Number	Source Select Bits for G1, G2 or Event (G1SRC[2:0], G2SRC[2:0] or EVSRC[2:0])	Trigger
1	000	AD2EVT
2	001	N2HET2[5]
3	010	N2HET1[27]
4	011	RTI compare 0
5	100	N2HET1[17]
6	101	N2HET1[19]
7	110	N2HET1[11]
8	111	N2HET2[13]

The selection between the default MIBADC2 event trigger hook-up versus the alternate event trigger hook-up is done by multiplexing control module register 30 bits 0 and 1.

If 30[0] = 1, then the default MibADC2 event trigger hook-up is used.

If 30[0] = 0 and 30[1] = 1, then the alternate MibADC2 event trigger hook-up is used.

NOTE

For AD2EVT trigger source, the connection to the MibADC2 module trigger input is made from the output side of the input buffer. This way, a trigger condition can be generated either by configuring AD2EVT as an output function on to the pad (via the mux control), or by driving the AD2EVT signal from an external trigger source as input. If the mux control module is used to select different functionality instead of the AD2EVT signal, then care must be taken to disable AD2EVT from triggering conversions; there is no multiplexing on the input connections.

NOTE

For N2HETx trigger sources, the connection to the MibADC2 module trigger input is made from the input side of the output buffer (at the N2HETx module boundary). This way, a trigger condition can be generated even if the N2HETx signal is not selected to be output on the pad.

NOTE

For the RTI compare 0 interrupt source, the connection is made directly from the output of the RTI module. That is, the interrupt condition can be used as a trigger source even if the actual interrupt is not signaled to the CPU.

7.2.3 ADC Electrical and Timing Specifications

Table 7-7. MibADC Recommended Operating Conditions

		MIN	MAX	UNIT
AD _{REFHI}	A-to-D high-voltage reference source	AD _{REFLO}	V _{CCAD}	V
AD _{REFLO}	A-to-D low-voltage reference source	V _{SSAD}	AD _{REFHI}	V
V _{AI}	Analog input voltage	AD _{REFLO}	AD _{REFHI}	V
I _{AIC}	Analog input clamp current (V _{AI} < V _{SSAD} – 0.3 or V _{AI} > V _{CCAD} + 0.3)	–2	2	mA

Table 7-8. MibADC Electrical Characteristics Over Full Ranges of Recommended Operating Conditions

PARAMETER	DESCRIPTION / TEST CONDITIONS	MIN	TYP	MAX	UNIT	
R _{mux}	Analog input mux on-resistance			250	Ω	
R _{samp}	ADC sample switch on-resistance			250	Ω	
C _{mux}	Input mux capacitance			16	pF	
C _{samp}	ADC sample capacitance			13	pF	
I _{AiL}	Analog off-state input leakage current	V _{CCAD} = 3.6 V maximum	V _{SSAD} ≤ V _{IN} < V _{SSAD} + 100 mV	–300	200	nA
			V _{SSAD} + 100 mV ≤ V _{IN} ≤ V _{CCAD} – 200 mV	–200	200	nA
			V _{CCAD} – 200 mV < V _{IN} ≤ V _{CCAD}	–200	500	nA
	Analog off-state input leakage current	V _{CCAD} = 5.5 V maximum	V _{SSAD} ≤ V _{IN} < V _{SSAD} + 300 mV	–1000	250	nA
			V _{SSAD} + 300 mV ≤ V _{IN} ≤ V _{CCAD} – 300 mV	–250	250	nA
			V _{CCAD} – 300 mV < V _{IN} ≤ V _{CCAD}	–250	1000	nA
I _{AOSB1} ⁽¹⁾	ADC1 Analog on-state input bias current	V _{CCAD} = 3.6 V maximum	V _{SSAD} ≤ V _{IN} < V _{SSAD} + 100 mV	–8	2	μA
			V _{SSAD} + 100 mV < V _{IN} < V _{CCAD} – 200 mV	–4	2	
			V _{CCAD} – 200 mV < V _{IN} < V _{CCAD}	–4	12	
I _{AOSB2} ⁽¹⁾	ADC2 Analog on-state input bias current	V _{CCAD} = 3.6V maximum	V _{SSAD} ≤ V _{IN} < V _{SSAD} + 100 mV	–7	2	μA
			V _{SSAD} + 100 mV ≤ V _{IN} ≤ V _{CCAD} – 200 mV	–4	2	
			V _{CCAD} – 200 mV < V _{IN} ≤ V _{CCAD}	–4	10	
I _{AOSB1} ⁽¹⁾	ADC1 Analog on-state input bias current	V _{CCAD} = 5.5V maximum	V _{SSAD} ≤ V _{IN} < V _{SSAD} + 300 mV	–10	3	μA
			V _{SSAD} + 300 mV ≤ V _{IN} ≤ V _{CCAD} – 300mV	–5	3	
			V _{CCAD} – 300 mV < V _{IN} ≤ V _{CCAD}	–5	14	
I _{AOSB2} ⁽¹⁾	ADC2 Analog on-state input bias current	V _{CCAD} = 5.5V maximum	V _{SSAD} ≤ V _{IN} < V _{SSAD} + 300 mV	–8	3	μA
			V _{SSAD} + 300 mV ≤ V _{IN} ≤ V _{CCAD} – 300 mV	–5	3	
			V _{CCAD} – 300 mV < V _{IN} ≤ V _{CCAD}	–5	12	
I _{ADREFHI}	AD _{REFHI} input current	AD _{REFHI} = V _{CCAD} ; AD _{REFLO} = V _{SSAD} ; –40°C to 125°C		3	mA	
I _{CCAD}	Static supply current	Normal operating mode; –40°C to 125°C		15	mA	
		ADC core in power down mode; –40°C to 125°C		5	μA	

(1) If a shared channel is being converted by both ADC converters at the same time, the on-state leakage is equal to I_{AOSL1} + I_{AOSL2}

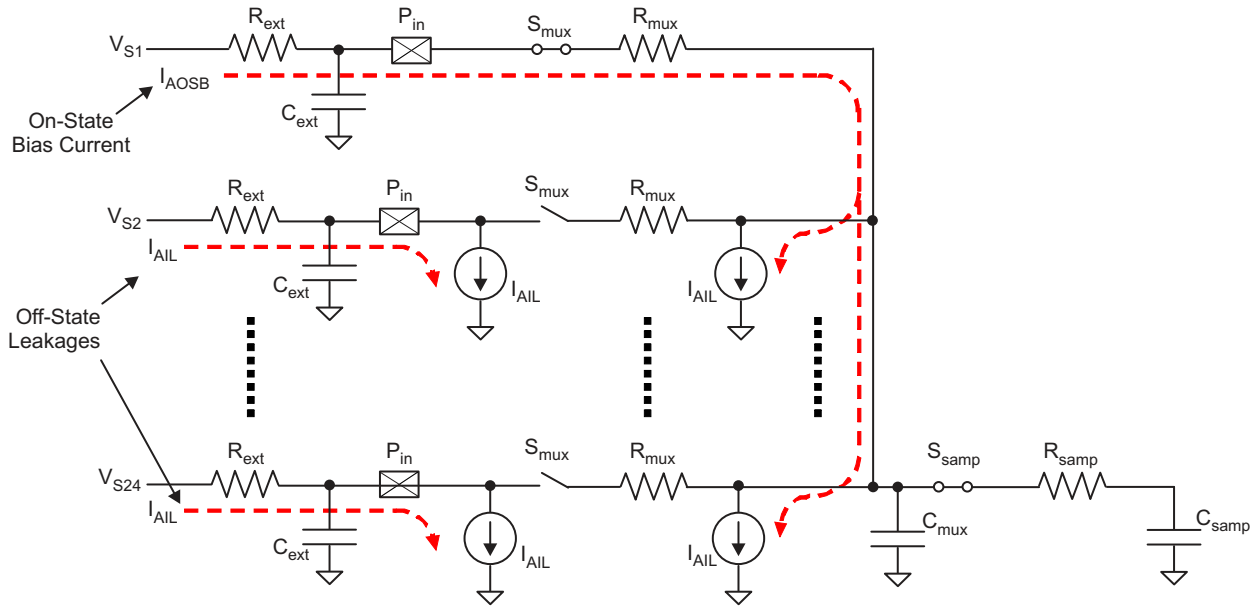

Figure 7-1. MibADC Input Equivalent Circuit

Table 7-9. MibADC Timing Specifications

			MIN	NOM	MAX	UNIT
$t_{c(ADCLK)}^{(1)}$	Cycle time, MibADC clock	-40°C to 125°C	0.033			μs
$t_{d(SH)}^{(2)}$	Delay time, sample and hold time	-40°C to 125°C	0.2			μs
$t_{d(PU-ADV)}$	Delay time from ADC power on until first input can be sampled	-40°C to 125°C	1			μs
12-bit mode						
$t_{d(c)}$	Delay time, conversion time	-40°C to 125°C	0.4			μs
$t_{d(SHC)}^{(3)}$	Delay time, total sample/hold and conversion time	-40°C to 125°C	0.6			μs
10-bit mode						
$t_{d(c)}$	Delay time, conversion time	-40°C to 125°C	0.33			μs
$t_{d(SHC)}^{(3)}$	Delay time, total sample/hold and conversion time	-40°C to 125°C	0.53			μs

- (1) The MibADC clock is the ADCLK, generated by dividing down the VCLK by a prescale factor defined by the ADCLOCKCR register bits 4:0.
- (2) The sample and hold time for the ADC conversions is defined by the ADCLK frequency and the AD<GP>SAMP register for each conversion group. The sample time needs to be determined by accounting for the external impedance connected to the input channel as well as the ADC's internal impedance.
- (3) This is the minimum sample/hold and conversion time that can be achieved. These parameters are dependent on many factors, e.g the prescale settings.

Table 7-10. MibADC Operating Characteristics Over Full Ranges of Recommended Operating Conditions

PARAMETER		DESCRIPTION / TEST CONDITIONS	MIN	NOM	MAX	UNIT	
CR	Conversion range over which specified accuracy is maintained	$AD_{REFHI} - AD_{REFLO}$	-40°C to 125°C		3	5.5	V
Z _{SET}	Zero Scale Offset	Difference between the first ideal transition (from code 000h to 001h) and the actual transition	10-bit mode; -40°C to 125°C			1	LSB ⁽¹⁾
			12-bit mode; -40°C to 125°C			2	LSB ⁽²⁾
F _{SET}	Full Scale Offset	Difference between the range of the measured code transitions (from first to last) and the range of the ideal code transitions	10-bit mode; -40°C to 125°C			2	LSB
			12-bit mode; -40°C to 125°C			3	LSB
E _{DNL}	Differential nonlinearity error	Difference between the actual step width and the ideal value. (See Figure 76)	10-bit mode			±1.5	LSB
			12-bit mode			±2	LSB
E _{INL}	Integral nonlinearity error	Maximum deviation from the best straight line through the MibADC. MibADC transfer characteristics, excluding the quantization error.	10-bit mode			±2	LSB
			12-bit mode			±2	LSB
E _{TOT}	Total unadjusted error	Maximum value of the difference between an analog value and the ideal midstep value.	10-bit mode			±2	LSB
			12-bit mode			±4	LSB

(1) 1 LSB = $(AD_{REFHI} - AD_{REFLO}) / 2^{10}$ for 10-bit mode(2) 1 LSB = $(AD_{REFHI} - AD_{REFLO}) / 2^{12}$ for 12-bit mode

7.2.4 Performance (Accuracy) Specifications

7.2.4.1 MibADC Nonlinearity Errors

The differential nonlinearity error shown in Figure 7-2 (sometimes referred to as differential linearity) is the difference between an actual step width and the ideal value of 1 LSB.

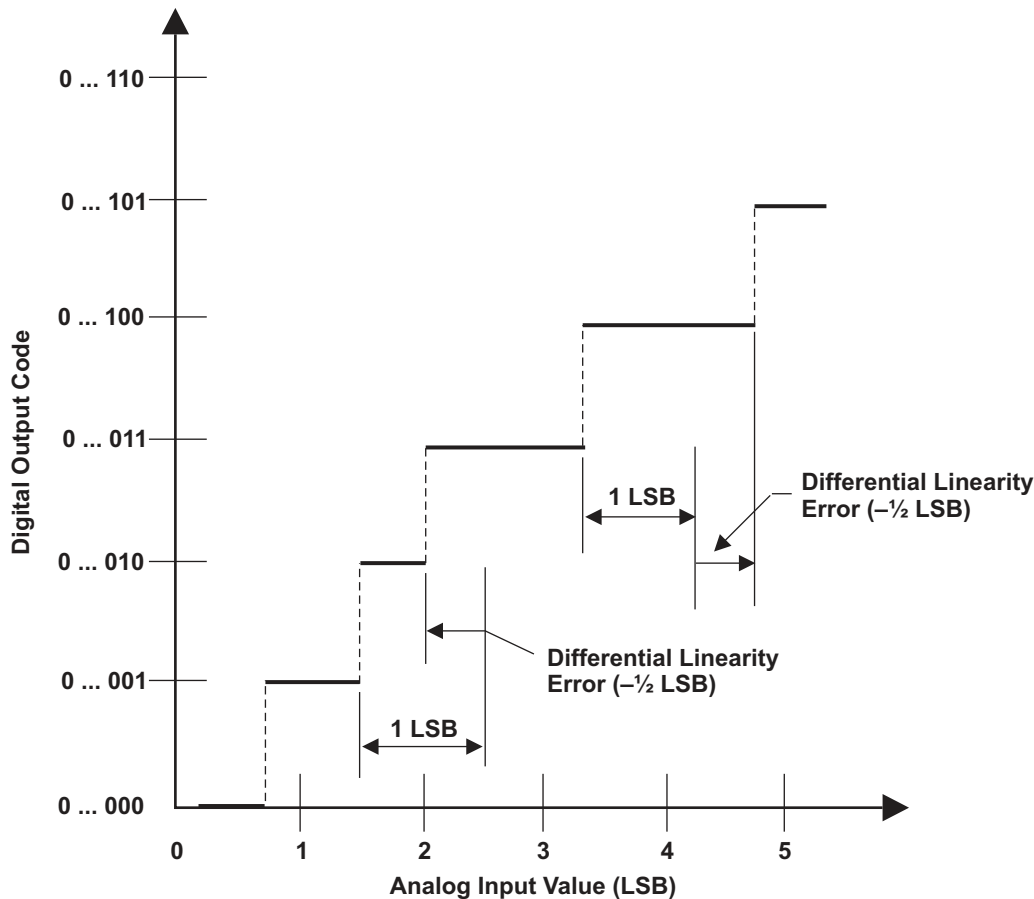

NOTE A: $1 \text{ LSB} = (AD_{\text{REFHI}} - AD_{\text{REFLO}}) / 2^{12}$

Figure 7-2. Differential Nonlinearity (DNL) Error

The integral nonlinearity error shown in Figure Figure 7-3 (sometimes referred to as linearity error) is the deviation of the values on the actual transfer function from a straight line.

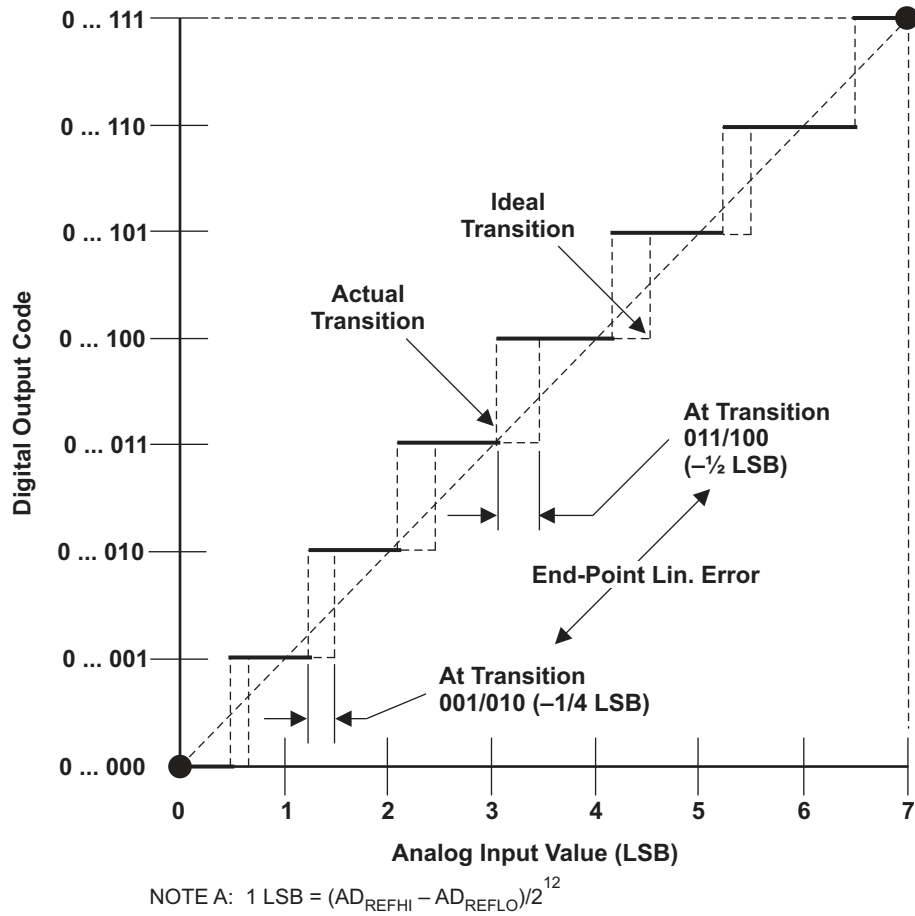

Figure 7-3. Integral Nonlinearity (INL) Error

7.2.4.2 MibADC Total Error

The absolute accuracy or total error of an MibADC as shown in Figure Figure 7-4 is the maximum value of the difference between an analog value and the ideal midstep value.

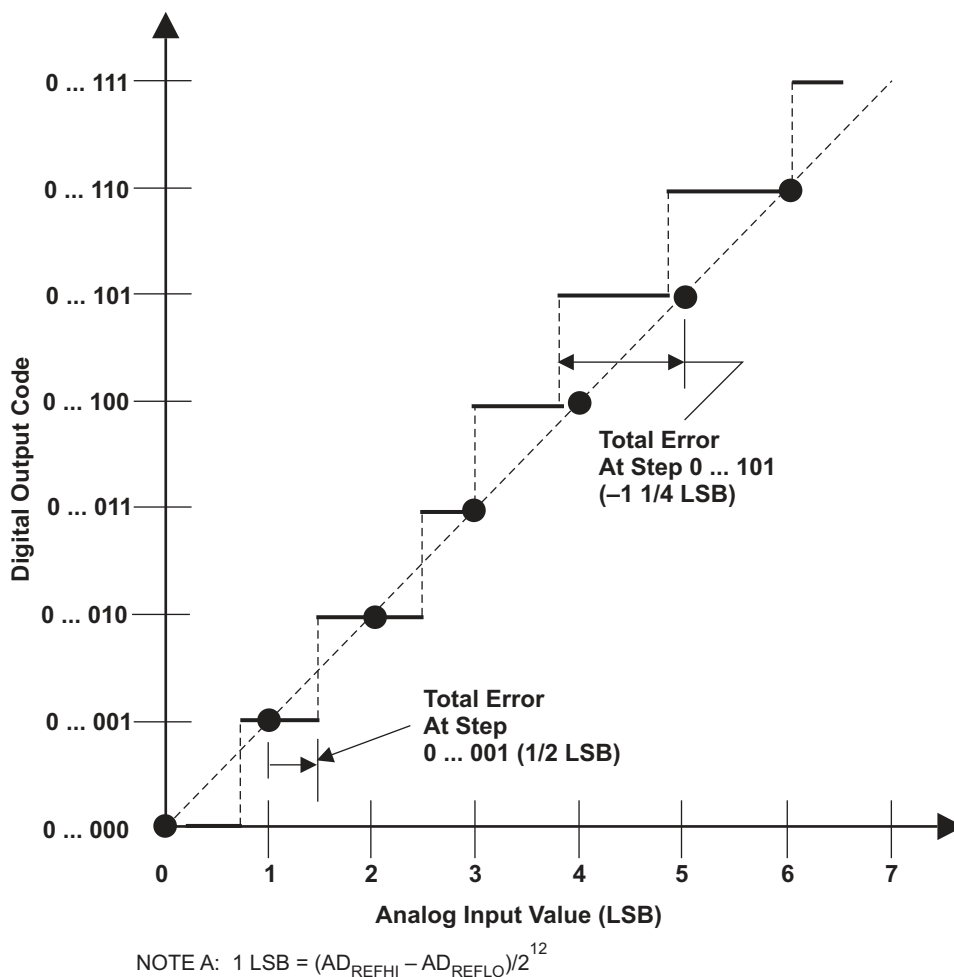

Figure 7-4. Absolute Accuracy (Total) Error

7.3 General-Purpose Input/Output

The GPIO module on this device supports two ports, GIOA and GIOB. The I/O pins are bidirectional and bit-programmable. Both GIOA and GIOB support external interrupt capability.

7.3.1 Features

The GPIO module has the following features:

- Each IO pin can be configured as:
 - Input
 - Output
 - Open Drain
- The interrupts have the following characteristics:
 - Programmable interrupt detection either on both edges or on a single edge (set in GIOINTDET)
 - Programmable edge-detection polarity, either rising or falling edge (set in GIOPOL register)
 - Individual interrupt flags (set in GIOFLG register)
 - Individual interrupt enables, set and cleared through GIOENASET and GIOENACLR registers respectively
 - Programmable interrupt priority, set through GIOLVLSET and GIOLVLCLR registers
- Internal pullup/pulldown allows unused I/O pins to be left unconnected

For information on input and output timings see [Section 5.11](#) and [Section 5.12](#)

7.4 Enhanced High-End Timer (N2HET)

The N2HET is an advanced intelligent timer that provides sophisticated timing functions for real-time applications. The timer is software-controlled, using a reduced instruction set, with a specialized timer micromachine and an attached I/O port. The N2HET can be used for pulse width modulated outputs, capture or compare inputs, or general-purpose I/O. It is especially well suited for applications requiring multiple sensor information and drive actuators with complex and accurate time pulses.

7.4.1 Features

The N2HET module has the following features:

- Programmable timer for input and output timing functions
- Reduced instruction set (30 instructions) for dedicated time and angle functions
- 160 words of instruction RAM protected by parity
- User defined number of 25-bit virtual counters for timer, event counters and angle counters
- 7-bit hardware counters for some pins allow up to 32-bit resolution in conjunction with the 25-bit virtual counters
- Up to 32 pins usable for input signal measurements or output signal generation
- Programmable suppression filter for each input pin with adjustable limiting frequency
- Low CPU overhead and interrupt load
- Efficient data transfer to or from the CPU memory with dedicated High-End-Timer Transfer Unit (HTU) or DMA
- Diagnostic capabilities with different loopback mechanisms and pin status readback functionality

7.4.2 N2HET RAM Organization

The timer RAM uses 4 RAM banks, where each bank has two port access capability. This means that one RAM address may be written while another address is read. The RAM words are 96-bits wide, which are split into three 32-bit fields (program, control, and data).

7.4.3 Input Timing Specifications

The N2HET instructions PCNT and WCAP impose some timing constraints on the input signals.

Table 7-11. Input Timing Requirements for the N2HET Input Capture Functionality

			MIN ⁽¹⁾ (2)	MAX ⁽¹⁾ (2)	UNI T
1	Input signal period, PCNT or WCAP for rising edge to rising edge	–40°C to 125°C	2 (hr) (lr) $t_{C(VCLK2)} + 2$	2^{25} (hr) (lr) $t_{C(VCLK2)} - 2$	ns
2	Input signal period, PCNT or WCAP for falling edge to falling edge	–40°C to 125°C	2 (hr) (lr) $t_{C(VCLK2)} + 2$	2^{25} (hr) (lr) $t_{C(VCLK2)} - 2$	ns
3	Input signal high phase, PCNT or WCAP for rising edge to falling edge	–40°C to 125°C	(hr) (lr) $t_{C(VCLK2)} + 2$	2^{25} (hr) (lr) $t_{C(VCLK2)} - 2$	ns
4	Input signal low phase, PCNT or WCAP for falling edge to rising edge	–40°C to 125°C	(hr) (lr) $t_{C(VCLK2)} + 2$	2^{25} (hr) (lr) $t_{C(VCLK2)} - 2$	ns

(1) hr = High-resolution prescaler, configured using the HRPFC field of the Prescale Factor Register (HETPFR).

(2) lr = Loop-resolution prescaler, configured using the LFPRC field of the Prescale Factor Register (HETPFR)

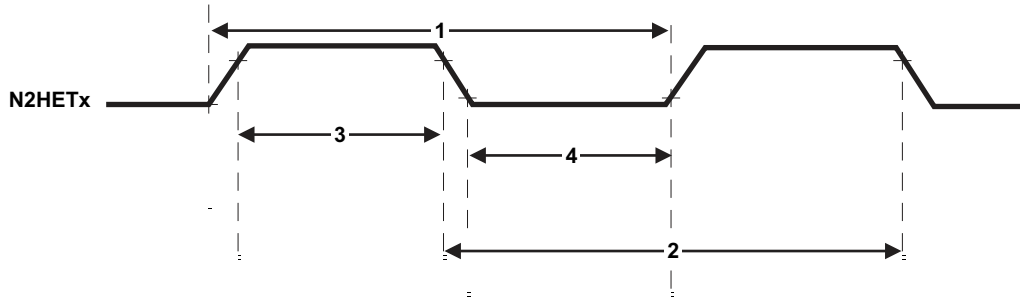

Figure 7-5. N2HET Input Capture Timings

Both N2HET1 and N2HET2 have channels that are enhanced to be able to capture inputs with smaller pulse widths than that specified in [Table 7-11](#). See [Table 7-13](#) for a list of which pins support small pulse capture.

The input capture capability for these channels is specified in the following table.

Table 7-12. Input Timing Requirements for N2HET Channels With Enhanced Pulse Capture

			MIN	MAX	UNIT
1	Input signal period, PCNT or WCAP for rising edge to rising edge	–40°C to 125°C	(hr) (lr) $t_{C(VCLK2)} + 2$	2^{25} (hr) (lr) $t_{C(VCLK2)} - 2$	ns
2	Input signal period, PCNT or WCAP for falling edge to falling edge	–40°C to 125°C	(hr) (lr) $t_{C(VCLK2)} + 2$	2^{25} (hr) (lr) $t_{C(VCLK2)} - 2$	ns
3	Input signal high phase, PCNT or WCAP for rising edge to falling edge	–40°C to 125°C	2 (hr) $t_{C(VCLK2)} + 2$	2^{25} (hr) (lr) $t_{C(VCLK2)} - 2$	ns
4	Input signal low phase, PCNT or WCAP for falling edge to rising edge	–40°C to 125°C	2 (hr) $t_{C(VCLK2)} + 2$	2^{25} (hr) (lr) $t_{C(VCLK2)} - 2$	ns

Table 7-13. Input Capture Pin Capability

Channel	Supports 32-bit Capture	Enhanced Pulse Capture
N2HET1[00]	Yes	No
N2HET1[01]	Yes	No
N2HET1[02]	Yes	No
N2HET1[03]	Yes	No
N2HET1[04]	Yes	No
N2HET1[05]	Yes	No
N2HET1[06]	Yes	No
N2HET1[07]	Yes	No
N2HET1[08]	Yes	No
N2HET1[09]	Yes	No
N2HET1[10]	Yes	No
N2HET1[11]	Yes	No
N2HET1[12]	Yes	No
N2HET1[13]	Yes	No
N2HET1[14]	Yes	No
N2HET1[15]	Yes	Yes
N2HET1[16]	Yes	No
N2HET1[17]	Yes	No
N2HET1[18]	Yes	No
N2HET1[19]	Yes	No
N2HET1[20]	Yes	Yes

Table 7-13. Input Capture Pin Capability (continued)

Channel	Supports 32-bit Capture	Enhanced Pulse Capture
N2HET1[21]	Yes	No
N2HET1[22]	Yes	No
N2HET1[23]	Yes	No
N2HET1[24]	Yes	No
N2HET1[25]	Yes	No
N2HET1[26]	Yes	No
N2HET1[27]	Yes	No
N2HET1[28]	Yes	No
N2HET1[29]	Yes	No
N2HET1[30]	Yes	No
N2HET1[31]	Yes	Yes
N2HET2[00]	Yes	No
N2HET2[01]	No	No
N2HET2[02]	No	No
N2HET2[03]	No	No
N2HET2[04]	Yes	No
N2HET2[05]	No	No
N2HET2[06]	Yes	No
N2HET2[07]	No	No
N2HET2[08]	No	No
N2HET2[09]	No	No
N2HET2[10]	No	No
N2HET2[11]	No	No
N2HET2[12]	Yes	Yes
N2HET2[13]	No	No
N2HET2[14]	Yes	Yes
N2HET2[15]	No	No
N2HET2[16]	Yes	Yes
N2HET2[18]	No	No

7.4.4 N2HET1-N2HET2 Interconnections

In some applications the N2HET resolutions must be synchronized. Some other applications require a single time base to be used for all PWM outputs and input timing captures.

The N2HET provides such a synchronization mechanism. The Clk_master/slave (HETGCR.16) configures the N2HET in master or slave mode (default is slave mode). A N2HET in master mode provides a signal to synchronize the prescalers of the slave N2HET. The slave N2HET synchronizes its loop resolution to the loop resolution signal sent by the master. The slave does not require this signal after it receives the first synchronization signal. However, anytime the slave receives the re-synchronization signal from the master, the slave must synchronize itself again..

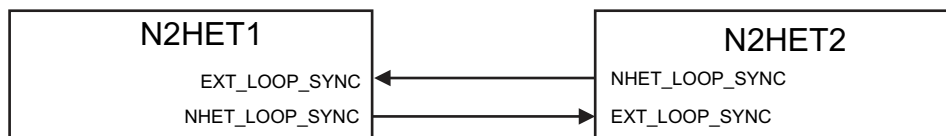

Figure 7-6. N2HET1 – N2HET2 Synchronization Hookup

7.4.5 N2HET Checking

7.4.5.1 Internal Monitoring

To assure correctness of the high-end timer operation and output signals, the two N2HET modules can be used to monitor each other's signals as shown in Figure 7-7. The direction of the monitoring is controlled by the I/O multiplexing control module.

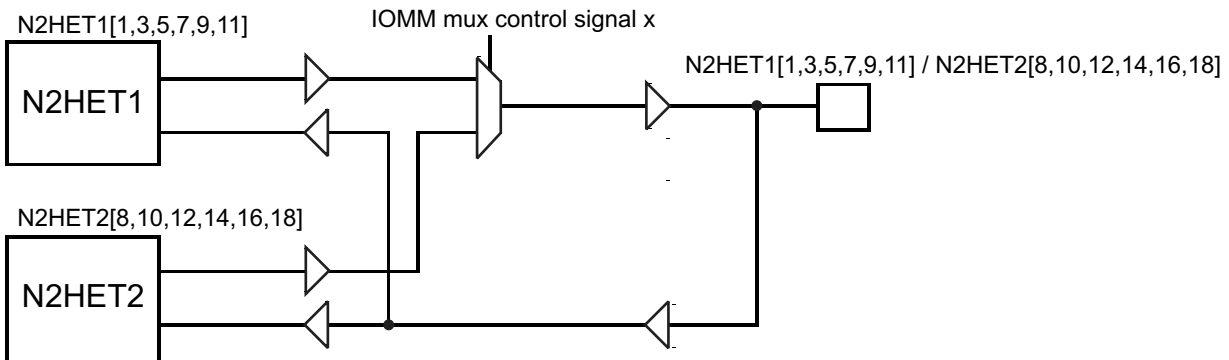

Figure 7-7. N2HET Monitoring

7.4.5.2 Output Monitoring using Dual Clock Comparator (DCC)

N2HET1[31] is connected as a clock source for counter 1 in DCC1. This allows the application to measure the frequency of the pulse-width modulated (PWM) signal on N2HET1[31].

Similarly, N2HET2[0] is connected as a clock source for counter 1 in DCC2. This allows the application to measure the frequency of the pulse-width modulated (PWM) signal on N2HET2[0].

Both N2HET1[31] and N2HET2[0] can be configured to be internal-only channels. That is, the connection to the DCC module is made directly from the output of the N2HETx module (from the input of the output buffer).

For more information on DCC see [Section 6.7.3](#).

7.4.6 Disabling N2HET Outputs

Some applications require the N2HET outputs to be disabled under some fault condition. The N2HET module provides this capability via the "Pin Disable" input signal. This signal, when driven low, causes the N2HET outputs identified by a programmable register (HETPINDIS) to be tri-stated. Please refer to the device specific technical reference manual for more details on the "N2HET Pin Disable" feature.

GIOA[5] is connected to the "Pin Disable" input for N2HET1, and GIOB[2] is connected to the "Pin Disable" input for N2HET2.

7.4.7 High-End Timer Transfer Unit (HET-TU)

A High End Timer Transfer Unit (HET-TU) can perform DMA type transactions to transfer N2HET data to or from main memory. A Memory Protection Unit (MPU) is built into the HET-TU.

7.4.7.1 Features

- CPU and DMA independent
- Master Port to access system memory
- 8 control packets supporting dual buffer configuration
- Control packet information is stored in RAM protected by parity
- Event synchronization (HET transfer requests)
- Supports 32 or 64 bit transactions
- Addressing modes for HET address (8 byte or 16 byte) and system memory address (fixed, 32 bit or 64bit)
- One shot, circular and auto switch buffer transfer modes
- Request lost detection

7.4.7.2 Trigger Connections

Table 7-14. HET TU1 Request Line Connection

Modules	Request Source	HET TU1 Request
N2HET1	HTUREQ[0]	HET TU1 DCP[0]
N2HET1	HTUREQ[1]	HET TU1 DCP[1]
N2HET1	HTUREQ[2]	HET TU1 DCP[2]
N2HET1	HTUREQ[3]	HET TU1 DCP[3]
N2HET1	HTUREQ[4]	HET TU1 DCP[4]
N2HET1	HTUREQ[5]	HET TU1 DCP[5]
N2HET1	HTUREQ[6]	HET TU1 DCP[6]
N2HET1	HTUREQ[7]	HET TU1 DCP[7]

Table 7-15. HET TU2 Request Line Connection

Modules	Request Source	HET TU2 Request
N2HET2	HTUREQ[0]	HET TU2 DCP[0]
N2HET2	HTUREQ[1]	HET TU2 DCP[1]
N2HET2	HTUREQ[2]	HET TU2 DCP[2]
N2HET2	HTUREQ[3]	HET TU2 DCP[3]
N2HET2	HTUREQ[4]	HET TU2 DCP[4]
N2HET2	HTUREQ[5]	HET TU2 DCP[5]
N2HET2	HTUREQ[6]	HET TU2 DCP[6]
N2HET2	HTUREQ[7]	HET TU2 DCP[7]

7.5 FlexRay Interface

The FlexRay module performs communication according to the FlexRay protocol specification v2.1. The sample clock bitrate can be programmed to values up to 10 MBit per second. Additional bus driver (BD) hardware is required for connection to the physical layer.

For communication on a FlexRay network, individual message buffers with up to 254 data bytes are configurable. The message storage consists of a single-ported message RAM that holds up to 128 message buffers. All functions concerning the handling of messages are implemented in the message handler. Those functions are the acceptance filtering, the transfer of messages between the two FlexRay Channel Protocol Controllers and the message RAM, maintaining the transmission schedule as well as providing message status information.

The register set of the FlexRay module can be accessed directly by the CPU via the VBUS interface. These registers are used to control, configure and monitor the FlexRay channel protocol controllers, message handler, global time unit, system universal control, frame/symbol processing, network management, interrupt control, and to access the message RAM via the input / output buffer.

7.5.1 Features

The FlexRay module has the following features:

- Conformance with FlexRay protocol specification v2.1
- Data rates of up to 10 Mb/s on each channel
- Up to 128 message buffers
- 8 Kbyte of message RAM for storage of, for example, 128 message buffers with max 48 byte data section or up to 30 message buffers with 254 byte data section
- Configuration of message buffers with different payload lengths
- One configurable receive FIFO
- Each message buffer can be configured as receive buffer, as transmit buffer or as part of the receive FIFO
- CPU access to message buffers via input and output buffer
- FlexRay transfer unit (FTU) for automatic data transfer between data memory and message buffers without CPU interaction
- Filtering for slot counter, cycle counter, and channel ID
- Maskable module interrupts
- Supports Network Management

7.5.2 Electrical and Timing Specifications

Table 7-16. Timing Requirements for FlexRay Inputs

			MIN	MAX	UNIT
t_{pw}	Input minimum pulse width to meet the FlexRay sampling requirement	-40°C to 125°C	$t_{c(AVCLK2)} + 2.5^{(1)}$		ns

(1) $t_{RxAsymDelay}$ parameter

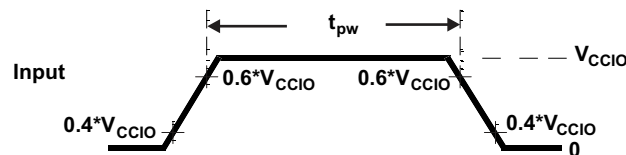

Figure 7-8. FlexRay Inputs

Table 7-17. FlexRay Jitter Timing

			MIN	MAX	UNIT
t_{Tx1bit}	Clock jitter and signal symmetry		98	102	ns
$t_{Tx10bit}$	FlexRay BSS (byte start sequence) to BSS	–40°C to 125°C	999	1001	ns
$t_{Tx10bitAvg}$	Average over 10000 samples	–40°C to 125°C	999.5	1000.5	ns
$t_{RxAsymDelay}$	Delay difference between rise and fall from Rx pin to sample point in FlexRay core	–40°C to 125°C	—	2.5	ns
$t_{jit}(SCLK)$	Jitter for the 80MHz Sample Clock generated by the PLL	–40°C to 125°C	—	0.5	ns

7.5.3 FlexRay Transfer Unit

The FlexRay Transfer Unit is able to transfer data between the input buffer (IBF) and output buffer (OBF) of the communication controller and the system memory without CPU interaction.

Because the FlexRay module is accessed through the FTU, the FTU must be powered up by the setting bit 23 in the Peripheral Power Down Registers of the System Module before accessing any FlexRay module register.

For more information on the FTU see the TMS570LS31X/TMS570LS21X Technical Reference Manual ([SPNU499](#)).

7.6 Controller Area Network (DCAN)

The DCAN supports the CAN 2.0B protocol standard and uses a serial, multimaster communication protocol that efficiently supports distributed real-time control with robust communication rates of up to 1 megabit per second (Mbps). The DCAN is ideal for applications operating in noisy and harsh environments (e.g., automotive and industrial fields) that require reliable serial communication or multiplexed wiring.

7.6.1 Features

Features of the DCAN module include:

- Supports CAN protocol version 2.0 part A, B
- Bit rates up to 1 MBit/s
- The CAN kernel can be clocked by the oscillator for baud-rate generation.
- 64 mailboxes on each DCAN
- Individual identifier mask for each message object
- Programmable FIFO mode for message objects
- Programmable loop-back modes for self-test operation
- Automatic bus on after Bus-Off state by a programmable 32-bit timer
- Message RAM protected by parity
- Direct access to Message RAM during test mode
- CAN Rx / Tx pins configurable as general purpose IO pins
- Message RAM Auto Initialization
- DMA support

For more information on the DCAN see the TMS570LS31X/21X Technical Reference Manual ([SPNU499](#)).

7.6.2 Electrical and Timing Specifications

Table 7-18. Dynamic Characteristics for the DCANx TX and RX pins

PARAMETER		MIN	MAX	UNIT
$t_{d(CANnTX)}$	Delay time, transmit shift register to CANnTX pin ⁽¹⁾		15	ns
$t_{d(CANnRX)}$	Delay time, CANnRX pin to receive shift register		5	ns

(1) These values do not include rise/fall times of the output buffer.

7.7 Local Interconnect Network Interface (LIN)

The SCI/LIN module can be programmed to work either as an SCI or as a LIN. The core of the module is an SCI. The SCI's hardware features are augmented to achieve LIN compatibility.

The SCI module is a universal asynchronous receiver-transmitter that implements the standard nonreturn to zero format. The SCI can be used to communicate, for example, through an RS-232 port or over a K-line.

The LIN standard is based on the SCI (UART) serial data link format. The communication concept is single-master/multiple-slave with a message identification for multi-cast transmission between any network nodes.

7.7.1 LIN Features

The following are features of the LIN module:

- Compatible to LIN 1.3, 2.0 and 2.1 protocols
- Multi-buffered receive and transmit units DMA capability for minimal CPU intervention
- Identification masks for message filtering
- Automatic Master Header Generation
 - Programmable Synch Break Field
 - Synch Field
 - Identifier Field
- Slave Automatic Synchronization
 - Synch break detection
 - Optional baudrate update
 - Synchronization Validation
- 2^{31} programmable transmission rates with 7 fractional bits
- Error detection
- 2 Interrupt lines with priority encoding

7.8 Serial Communication Interface (SCI)

7.8.1 Features

- Standard universal asynchronous receiver-transmitter (UART) communication
- Supports full- or half-duplex operation
- Standard nonreturn to zero (NRZ) format
- Double-buffered receive and transmit functions
- Configurable frame format of 3 to 13 bits per character based on the following:
 - Data word length programmable from one to eight bits
 - Additional address bit in address-bit mode
 - Parity programmable for zero or one parity bit, odd or even parity
 - Stop programmable for one or two stop bits
- Asynchronous or isosynchronous communication modes
- Two multiprocessor communication formats allow communication between more than two devices.
- Sleep mode is available to free CPU resources during multiprocessor communication.
- The 24-bit programmable baud rate supports 2^{24} different baud rates provide high accuracy baud rate selection.
- Four error flags and Five status flags provide detailed information regarding SCI events.
- Capability to use DMA for transmit and receive data.

7.9 Inter-Integrated Circuit (I2C)

The inter-integrated circuit (I2C) module is a multi-master communication module providing an interface between the microcontroller and devices compliant with Philips Semiconductor I2C-bus specification version 2.1 and connected by an I2C-bus. This module will support any slave or master I2C compatible device.

7.9.1 Features

The I2C has the following features:

- Compliance to the Philips I2C bus specification, v2.1 (The I²C Specification, Philips document number 9398 393 40011)
 - Bit/Byte format transfer
 - 7-bit and 10-bit device addressing modes
 - General call
 - START byte
 - Multi-master transmitter/ slave receiver mode
 - Multi-master receiver/ slave transmitter mode
 - Combined master transmit/receive and receive/transmit mode
 - Transfer rates of 10 kbps up to 400 kbps (Phillips fast-mode rate)
- Free data format
- Two DMA events (transmit and receive)
- DMA event enable/disable capability
- Seven interrupts that can be used by the CPU
- Module enable/disable capability
- The SDA and SCL are optionally configurable as general purpose I/O
- Slew rate control of the outputs
- Open drain control of the outputs
- Programmable pullup/pulldown capability on the inputs
- Supports Ignore NACK mode

NOTE

This I2C module does not support:

- High-speed (HS) mode
 - C-bus compatibility mode
 - The combined format in 10-bit address mode (the I²C sends the slave address second byte every time it sends the slave address first byte)
-

7.9.2 I²C I/O Timing Specifications

Table 7-19. I²C Signals (SDA and SCL) Switching Characteristics⁽¹⁾

PARAMETER		STANDARD MODE		FAST MODE		UNIT
		MIN	MAX	MIN	MAX	
t _{c(I2CCLK)}	Cycle time, internal module clock for I ² C, prescaled from VCLK	75.2	149	75.2	149	ns
f _(SCL)	SCL clock frequency	0	100	0	400	kHz
t _{c(SCL)}	Cycle time, SCL	10		2.5		μs
t _{su(SCLH-SDAL)}	Setup time, SCL high before SDA low (for a repeated START condition)	4.7		0.6		μs
t _{h(SCLL-SDAL)}	Hold time, SCL low after SDA low (for a repeated START condition)	4		0.6		μs
t _{w(SCLL)}	Pulse duration, SCL low	4.7		1.3		μs
t _{w(SCLH)}	Pulse duration, SCL high	4		0.6		μs
t _{su(SDA-SCLH)}	Setup time, SDA valid before SCL high	250		100		ns
t _{h(SDA-SCLL)}	Hold time, SDA valid after SCL low (for I2C bus devices)	0	3.45 ⁽²⁾	0	0.9	μs
t _{w(SDAH)}	Pulse duration, SDA high between STOP and START conditions	4.7		1.3		μs
t _{su(SCLH-SDAH)}	Setup time, SCL high before SDA high (for STOP condition)	4.0		0.6		μs
t _{w(SP)}	Pulse duration, spike (must be suppressed)			0	50	ns
C _b ⁽³⁾	Capacitive load for each bus line		400		400	pF

- (1) The I2C pins SDA and SCL do not feature fail-safe I/O buffers. These pins could potentially draw current when the device is powered down.
- (2) The maximum t_{h(SDA-SCLL)} for I2C bus devices has only to be met if the device does not stretch the low period (t_{w(SCLL)}) of the SCL signal.
- (3) C_b = The total capacitance of one bus line in pF.

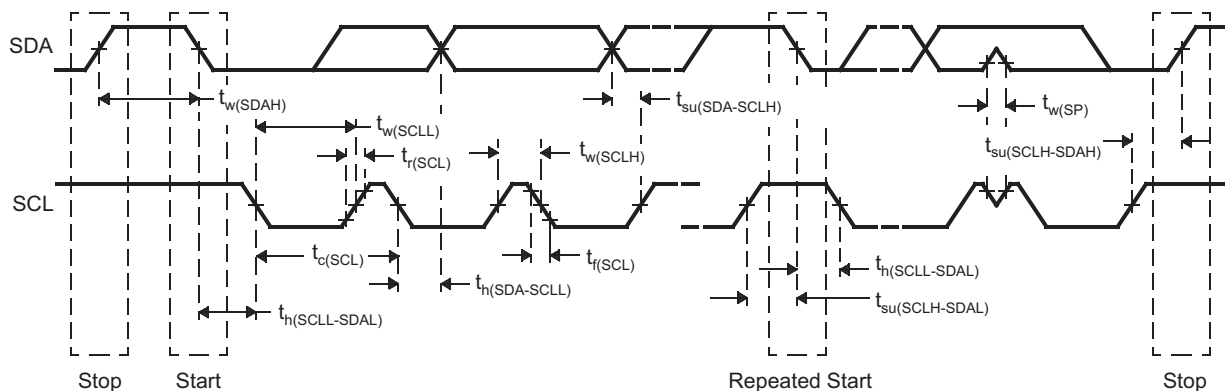

Figure 7-9. I²C Timings

NOTE

- A device must internally provide a hold time of at least 300 ns for the SDA signal (referred to the VIHmin of the SCL signal) to bridge the undefined region of the falling edge of SCL.
 - The maximum $t_{h(SDA-SCLL)}$ has only to be met if the device does not stretch the LOW period ($t_{w(SCLL)}$) of the SCL signal.
 - A Fast-mode I2C-bus device can be used in a Standard-mode I2C-bus system, but the requirement $t_{su(SDA-SCLH)} \geq 250$ ns must then be met. This will automatically be the case if the device does not stretch the LOW period of the SCL signal. If such a device does stretch the LOW period of the SCL signal, it must output the next data bit to the SDA line $t_{r\ max} + t_{su(SDA-SCLH)}$.
 - C_b = total capacitance of one bus line in pF. If mixed with fast-mode devices, faster fall-times are allowed.
-

7.10 Multi-Buffered / Standard Serial Peripheral Interface

The MibSPI is a high-speed synchronous serial input/output port that allows a serial bit stream of programmed length (2 to 16 bits) to be shifted in and out of the device at a programmed bit-transfer rate. Typical applications for the SPI include interfacing to external peripherals, such as I/Os, memories, display drivers, and analog-to-digital converters.

7.10.1 Features

Both Standard and MibSPI modules have the following features:

- 16-bit shift register
- Receive buffer register
- 5-bit baud clock generator
- SPICLK can be internally-generated (master mode) or received from an external clock source (slave mode)
- Each word transferred can have a unique format
- SPI I/Os not used in the communication can be used as digital input/output signals

Table 7-20. MibSPI/SPI Configurations

MibSPIx/SPIx	I/Os
MibSPI1	MIBSPI1SIMO[1:0], MIBSPI1SOMI[1:0], MIBSPI1CLK, MIBSPI1nCS[5:0], MIBSPI1nENA
MibSPI3	MIBSPI3SIMO, MIBSPI3SOMI, MIBSPI3CLK, MIBSPI3nCS[5:0], MIBSPI3nENA
MibSPI5	MIBSPI5SIMO[3:0], MIBSPI5SOMI[3:0], MIBSPI5CLK, MIBSPI5nCS[3:0], MIBSPI5nENA
SPI2	SPI2SIMO, SPI2SOMI, SPI2CLK, SPI2nCS[1:0], SPI2nENA
SPI4	SPI4SIMO, SPI4SOMI, SPI4CLK, SPI4nCS[0], SPI4nENA

7.10.2 MibSPI Transmit and Receive RAM Organization

The Multibuffer RAM is comprised of 128 buffers. Each entry in the Multibuffer RAM consists of 4 parts: a 16-bit transmit field, a 16-bit receive field, a 16-bit control field and a 16-bit status field. The Multibuffer RAM can be partitioned into multiple transfer group with variable number of buffers each.

7.10.3 MibSPI Transmit Trigger Events

Each of the transfer groups can be configured individually. For each of the transfer groups a trigger event and a trigger source can be chosen. A trigger event can be for example a rising edge or a permanent low level at a selectable trigger source. For example, up to 15 trigger sources are available which can be utilized by each transfer group. These trigger options are listed in [Table 7-21](#) for MIBSPI1, [Section 7.10.3.2](#) for MIBSPI3 and [Section 7.10.3.3](#) for MibSPI5.

7.10.3.1 MIBSPI1 Event Trigger Hookup

Table 7-21. MIBSPI1 Event Trigger Hookup

Event Number	TGxCTRL TRIGSRC[3:0]	Trigger
Disabled	0000	No trigger source
EVENT0	0001	GIOA[0]
EVENT1	0010	GIOA[1]
EVENT2	0011	GIOA[2]
EVENT3	0100	GIOA[3]
EVENT4	0101	GIOA[4]
EVENT5	0110	GIOA[5]
EVENT6	0111	GIOA[6]
EVENT7	1000	GIOA[7]
EVENT8	1001	N2HET1[8]
EVENT9	1010	N2HET1[10]
EVENT10	1011	N2HET1[12]
EVENT11	1100	N2HET1[14]
EVENT12	1101	N2HET1[16]
EVENT13	1110	N2HET1[18]
EVENT14	1111	Internal Tick counter

NOTE

For N2HET1 trigger sources, the connection to the MibSPI1 module trigger input is made from the input side of the output buffer (at the N2HET1 module boundary). This way, a trigger condition can be generated even if the N2HET1 signal is not selected to be output on the pad.

NOTE

For GIOx trigger sources, the connection to the MibSPI1 module trigger input is made from the output side of the input buffer. This way, a trigger condition can be generated either by selecting the GIOx pin as an output pin plus selecting the pin to be a GIOx pin, or by driving the GIOx pin from an external trigger source. If the mux control module is used to select different functionality instead of the GIOx signal, then care must be taken to disable GIOx from triggering MibSPI1 transfers; there is no multiplexing on the input connections.

7.10.3.2 MIBSPI3 Event Trigger Hookup

Table 7-22. MIBSPI3 Event Trigger Hookup

Event Number	TGxCTRL TRIGSRC[3:0]	Trigger
Disabled	0000	No trigger source
EVENT0	0001	GIOA[0]
EVENT1	0010	GIOA[1]
EVENT2	0011	GIOA[2]
EVENT3	0100	GIOA[3]
EVENT4	0101	GIOA[4]
EVENT5	0110	GIOA[5]
EVENT6	0111	GIOA[6]
EVENT7	1000	GIOA[7]

Table 7-22. MIBSPI3 Event Trigger Hookup (continued)

Event Number	TGxCTRL TRIGSRC[3:0]	Trigger
EVENT8	1001	HET[8]
EVENT9	1010	N2HET1[10]
EVENT10	1011	N2HET1[12]
EVENT11	1100	N2HET1[14]
EVENT12	1101	N2HET1[16]
EVENT13	1110	N2HET1[18]
EVENT14	1111	Internal Tick counter

NOTE

For N2HET1 trigger sources, the connection to the MibSPI3 module trigger input is made from the input side of the output buffer (at the N2HET1 module boundary). This way, a trigger condition can be generated even if the N2HET1 signal is not selected to be output on the pad.

NOTE

For GIOx trigger sources, the connection to the MibSPI3 module trigger input is made from the output side of the input buffer. This way, a trigger condition can be generated either by selecting the GIOx pin as an output pin plus selecting the pin to be a GIOx pin, or by driving the GIOx pin from an external trigger source. If the mux control module is used to select different functionality instead of the GIOx signal, then care must be taken to disable GIOx from triggering MibSPI3 transfers; there is no multiplexing on the input connections.

7.10.3.3 MIBSPI5 Event Trigger Hookup**Table 7-23. MIBSPI5 Event Trigger Hookup**

Event Number	TGxCTRL TRIGSRC[3:0]	Trigger
Disabled	0000	No trigger source
EVENT0	0001	GIOA[0]
EVENT1	0010	GIOA[1]
EVENT2	0011	GIOA[2]
EVENT3	0100	GIOA[3]
EVENT4	0101	GIOA[4]
EVENT5	0110	GIOA[5]
EVENT6	0111	GIOA[6]
EVENT7	1000	GIOA[7]
EVENT8	1001	N2HET1[8]
EVENT9	1010	N2HET1[10]
EVENT10	1011	N2HET1[12]
EVENT11	1100	N2HET1[14]
EVENT12	1101	N2HET1[16]
EVENT13	1110	N2HET1[18]
EVENT14	1111	Internal Tick counter

NOTE

For N2HET1 trigger sources, the connection to the MibSPI5 module trigger input is made from the input side of the output buffer (at the N2HET1 module boundary). This way, a trigger condition can be generated even if the N2HET1 signal is not selected to be output on the pad.

NOTE

For GIOx trigger sources, the connection to the MibSPI5 module trigger input is made from the output side of the input buffer. This way, a trigger condition can be generated either by selecting the GIOx pin as an output pin + selecting the pin to be a GIOx pin, or by driving the GIOx pin from an external trigger source. If the mux control module is used to select different functionality instead of the GIOx signal, then care must be taken to disable GIOx from triggering MibSPI5 transfers; there is no multiplexing on the input connections.

7.10.4 MibSPI/SPI Master Mode I/O Timing Specifications

Table 7-24. SPI Master Mode External Timing Parameters (CLOCK PHASE = 0, SPICLK = output, SPISIMO = output, and SPISOMI = input)⁽¹⁾⁽²⁾⁽³⁾

NO.			MIN	MAX	UNIT
1	$t_{c(SPC)M}$	Cycle time, SPICLK ⁽⁴⁾		40	$256t_{c(VCLK)}$ ns
2 ⁽⁵⁾	$t_{w(SPCH)M}$	Pulse duration, SPICLK high (clock polarity = 0)	–40°C to 125°C	$0.5t_{c(SPC)M} - t_{f(SPC)M} - 3$	$0.5t_{c(SPC)M} + 3$ ns
	$t_{w(SPCL)M}$	Pulse duration, SPICLK low (clock polarity = 1)	–40°C to 125°C	$0.5t_{c(SPC)M} - t_{f(SPC)M} - 3$	$0.5t_{c(SPC)M} + 3$ ns
3 ⁽⁵⁾	$t_{w(SPCL)M}$	Pulse duration, SPICLK low (clock polarity = 0)	–40°C to 125°C	$0.5t_{c(SPC)M} - t_{f(SPC)M} - 3$	$0.5t_{c(SPC)M} + 3$ ns
	$t_{w(SPCH)M}$	Pulse duration, SPICLK high (clock polarity = 1)	–40°C to 125°C	$0.5t_{c(SPC)M} - t_{f(SPC)M} - 3$	$0.5t_{c(SPC)M} + 3$ ns
4 ⁽⁵⁾	$t_{d(SPCH-SIMO)M}$	Delay time, SPISIMO valid before SPICLK low (clock polarity = 0)		$0.5t_{c(SPC)M} - 6$	ns
	$t_{d(SPCL-SIMO)M}$	Delay time, SPISIMO valid before SPICLK high (clock polarity = 1)		$0.5t_{c(SPC)M} - 6$	ns
5 ⁽⁵⁾	$t_{v(SPCL-SIMO)M}$	Valid time, SPISIMO data valid after SPICLK low (clock polarity = 0)		$0.5t_{c(SPC)M} - t_{f(SPC)} - 4$	ns
	$t_{v(SPCH-SIMO)M}$	Valid time, SPISIMO data valid after SPICLK high (clock polarity = 1)		$0.5t_{c(SPC)M} - t_{f(SPC)} - 4$	ns
6 ⁽⁵⁾	$t_{su(SOMI-SPCL)M}$	Setup time, SPISOMI before SPICLK low (clock polarity = 0)		$t_{f(SPC)} + 2.2$	ns
	$t_{su(SOMI-SPCH)M}$	Setup time, SPISOMI before SPICLK high (clock polarity = 1)		$t_{f(SPC)} + 2.2$	ns
7 ⁽⁵⁾	$t_{h(SPCL-SOMI)M}$	Hold time, SPISOMI data valid after SPICLK low (clock polarity = 0)		10	ns
	$t_{h(SPCH-SOMI)M}$	Hold time, SPISOMI data valid after SPICLK high (clock polarity = 1)		10	ns
8 ⁽⁶⁾	$t_{C2DELAY}$	Setup time CS active until SPICLK high (clock polarity = 0)	CSHOLD = 0	$C2TDELAY * t_{c(VCLK)} + (C2TDELAY + 2) * t_{c(VCLK)} - 2 * t_{c(VCLK)} - t_{f(SPICS)} + t_{f(SPC)} - 7$	ns
			CSHOLD = 1	$C2TDELAY * t_{c(VCLK)} + (C2TDELAY + 3) * t_{c(VCLK)} - 3 * t_{c(VCLK)} - t_{f(SPICS)} + t_{f(SPC)} - 7$	
	$t_{C2DELAY}$	Setup time CS active until SPICLK low (clock polarity = 1)	CSHOLD = 0	$C2TDELAY * t_{c(VCLK)} + (C2TDELAY + 2) * t_{c(VCLK)} - 2 * t_{c(VCLK)} - t_{f(SPICS)} + t_{f(SPC)} - 7$	ns
			CSHOLD = 1	$C2TDELAY * t_{c(VCLK)} + (C2TDELAY + 3) * t_{c(VCLK)} - 3 * t_{c(VCLK)} - t_{f(SPICS)} + t_{f(SPC)} - 7$	

(1) The MASTER bit (SPIGCR1.0) is set and the CLOCK PHASE bit (SPIFMTx.16) is set.

(2) $t_{c(VCLK)}$ = interface clock cycle time = $1 / f_{(VCLK)}$

(3) For rise and fall timings, see [Table 5-6](#).

(4) When the SPI is in master mode, the following must be true:

For PS values from 1 to 255: $t_{c(SPC)M} \geq (PS + 1) t_{c(VCLK)} \geq 40$ ns, where PS is the prescale value set in the SPIFMTx.[15:8] register bits.

For PS values of 0: $t_{c(SPC)M} = 2t_{c(VCLK)} \geq 40$ ns.

The external load on the SPICLK pin must be less than 60 pF.

(5) The active edge of the SPICLK signal referenced by the CLOCK POLARITY bit (SPIFMTx.17).

(6) C2TDELAY and T2CDELAY is programmed in the SPIDELAY register

Table 7-24. SPI Master Mode External Timing Parameters (CLOCK PHASE = 0, SPICLK = output, SPISIMO = output, and SPISOMI = input)⁽¹⁾⁽²⁾⁽³⁾ (continued)

NO.				MIN	MAX	UNIT
9 ⁽⁶⁾	t _{T2CDELAY}	Hold time SPICLK low until CS inactive (clock polarity = 0)		$0.5 \cdot t_{c(SPC)M} + T2CDELAY \cdot t_{c(VCLK)} + t_{c(VCLK)} - t_f(SPC) + t_r(SPICS) - 7$	$0.5 \cdot t_{c(SPC)M} + T2CDELAY \cdot t_{c(VCLK)} + t_{c(VCLK)} - t_f(SPC) + t_r(SPICS) + 11$	ns
		Hold time SPICLK high until CS inactive (clock polarity = 1)		$0.5 \cdot t_{c(SPC)M} + T2CDELAY \cdot t_{c(VCLK)} + t_{c(VCLK)} - t_f(SPC) + t_r(SPICS) - 7$	$0.5 \cdot t_{c(SPC)M} + T2CDELAY \cdot t_{c(VCLK)} + t_{c(VCLK)} - t_f(SPC) + t_r(SPICS) + 11$	ns
10	t _{SPIENA}	SPIENAn Sample point		$(C2TDELAY + 1) \cdot t_{c(VCLK)} - t_f(SPICS) - 29$	$(C2TDELAY + 1) \cdot t_{c(VCLK)}$	ns
11	t _{SPIENAW}	SPIENAn Sample point from write to buffer	-40°C to 125°C		$(C2TDELAY + 2) \cdot t_{c(VCLK)}$	ns

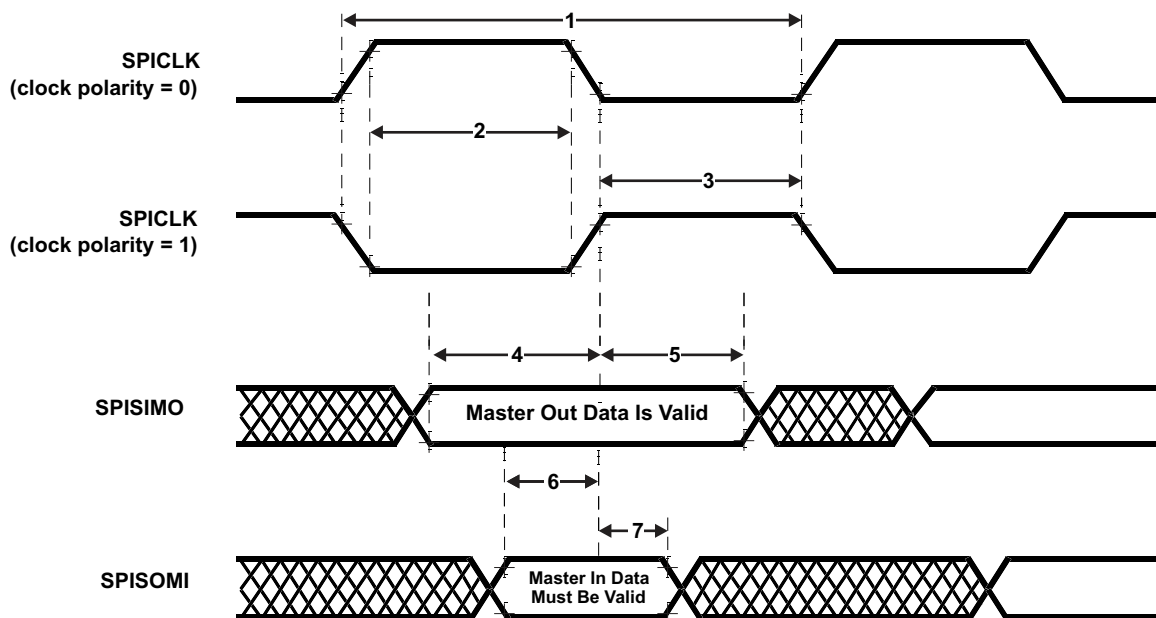

Figure 7-10. SPI Master Mode External Timing (CLOCK PHASE = 0)

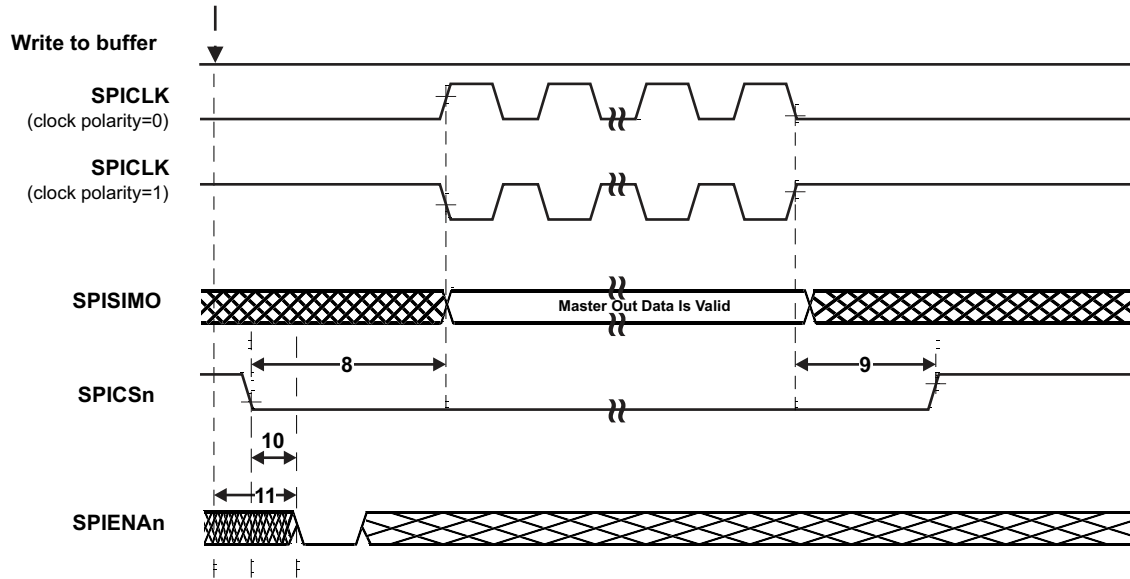

Figure 7-11. SPI Master Mode Chip Select Timing (CLOCK PHASE = 0)

Table 7-25. SPI Master Mode External Timing Parameters (CLOCK PHASE = 1, SPICLK = output, SPISIMO = output, and SPISOMI = input)⁽¹⁾⁽²⁾⁽³⁾

NO.			MIN	MAX	UNIT	
1	$t_{c(SPC)M}$	Cycle time, SPICLK ⁽⁴⁾	40	$256t_{c(VCLK)}$	ns	
2 ⁽⁵⁾	$t_{w(SPCH)M}$	Pulse duration, SPICLK high (clock polarity = 0)	$-40^{\circ}\text{C to }125^{\circ}\text{C}$	$0.5t_{c(SPC)M} - t_{f(SPC)M} - 3$	$0.5t_{c(SPC)M} + 3$	ns
	$t_{w(SPCL)M}$	Pulse duration, SPICLK low (clock polarity = 1)	$-40^{\circ}\text{C to }125^{\circ}\text{C}$	$0.5t_{c(SPC)M} - t_{f(SPC)M} - 3$	$0.5t_{c(SPC)M} + 3$	
3 ⁽⁵⁾	$t_{w(SPCL)M}$	Pulse duration, SPICLK low (clock polarity = 0)	$-40^{\circ}\text{C to }125^{\circ}\text{C}$	$0.5t_{c(SPC)M} - t_{f(SPC)M} - 3$	$0.5t_{c(SPC)M} + 3$	ns
	$t_{w(SPCH)M}$	Pulse duration, SPICLK high (clock polarity = 1)	$-40^{\circ}\text{C to }125^{\circ}\text{C}$	$0.5t_{c(SPC)M} - t_{f(SPC)M} - 3$	$0.5t_{c(SPC)M} + 3$	
4 ⁽⁵⁾	$t_{v(SIMO-SPCH)M}$	Valid time, SPICLK high after SPISIMO data valid (clock polarity = 0)		$0.5t_{c(SPC)M} - 6$		ns
	$t_{v(SIMO-SPCL)M}$	Valid time, SPICLK low after SPISIMO data valid (clock polarity = 1)		$0.5t_{c(SPC)M} - 6$		
5 ⁽⁵⁾	$t_{v(SPCH-SIMO)M}$	Valid time, SPISIMO data valid after SPICLK high (clock polarity = 0)		$0.5t_{c(SPC)M} - t_{f(SPC)} - 4$		ns
	$t_{v(SPCL-SIMO)M}$	Valid time, SPISIMO data valid after SPICLK low (clock polarity = 1)		$0.5t_{c(SPC)M} - t_{f(SPC)} - 4$		
6 ⁽⁵⁾	$t_{su(SOMI-SPCH)M}$	Setup time, SPISOMI before SPICLK high (clock polarity = 0)		$t_{f(SPC)} + 2.2$		ns
	$t_{su(SOMI-SPCL)M}$	Setup time, SPISOMI before SPICLK low (clock polarity = 1)		$t_{f(SPC)} + 2.2$		
7 ⁽⁵⁾	$t_{v(SPCH-SOMI)M}$	Valid time, SPISOMI data valid after SPICLK high (clock polarity = 0)		10		ns
	$t_{v(SPCL-SOMI)M}$	Valid time, SPISOMI data valid after SPICLK low (clock polarity = 1)		10		
8 ⁽⁶⁾	$t_{C2TDELAY}$	Setup time CS active until SPICLK high (clock polarity = 0)	CSHOLD = 0	$0.5 * t_{c(SPC)M} + (C2TDELAY + 2) * t_{c(VCLK)} - t_{f(SPICS)} + t_{f(SPC)} - 7$	$0.5 * t_{c(SPC)M} + (C2TDELAY + 2) * t_{c(VCLK)} - t_{f(SPICS)} + t_{f(SPC)} + 5.5$	ns
			CSHOLD = 1	$0.5 * t_{c(SPC)M} + (C2TDELAY + 3) * t_{c(VCLK)} - t_{f(SPICS)} + t_{f(SPC)} - 7$	$0.5 * t_{c(SPC)M} + (C2TDELAY + 3) * t_{c(VCLK)} - t_{f(SPICS)} + t_{f(SPC)} + 5.5$	
	$t_{C2TDELAY}$	Setup time CS active until SPICLK low (clock polarity = 1)	CSHOLD = 0	$0.5 * t_{c(SPC)M} + (C2TDELAY + 2) * t_{c(VCLK)} - t_{f(SPICS)} + t_{f(SPC)} - 7$	$0.5 * t_{c(SPC)M} + (C2TDELAY + 2) * t_{c(VCLK)} - t_{f(SPICS)} + t_{f(SPC)} + 5.5$	ns
			CSHOLD = 1	$0.5 * t_{c(SPC)M} + (C2TDELAY + 3) * t_{c(VCLK)} - t_{f(SPICS)} + t_{f(SPC)} - 7$	$0.5 * t_{c(SPC)M} + (C2TDELAY + 3) * t_{c(VCLK)} - t_{f(SPICS)} + t_{f(SPC)} + 5.5$	
9 ⁽⁶⁾	$t_{T2CDELAY}$	Hold time SPICLK low until CS inactive (clock polarity = 0)		$T2CDELAY * t_{c(VCLK)} + t_{c(VCLK)} - t_{f(SPC)} + t_{f(SPICS)} - 7$	$T2CDELAY * t_{c(VCLK)} + t_{c(VCLK)} - t_{f(SPC)} + t_{f(SPICS)} + 11$	ns
		Hold time SPICLK high until CS inactive (clock polarity = 1)		$T2CDELAY * t_{c(VCLK)} + t_{c(VCLK)} - t_{f(SPC)} + t_{f(SPICS)} - 7$	$T2CDELAY * t_{c(VCLK)} + t_{c(VCLK)} - t_{f(SPC)} + t_{f(SPICS)} + 11$	ns

(1) The MASTER bit (SPIGCR1.0) is set and the CLOCK PHASE bit (SPIFMTx.16) is set.

(2) $t_{c(VCLK)}$ = interface clock cycle time = $1 / f_{(VCLK)}$

(3) For rise and fall timings, see the [Table 5-6](#).

(4) When the SPI is in Master mode, the following must be true:

For PS values from 1 to 255: $t_{c(SPC)M} \geq (PS + 1)t_{c(VCLK)} \geq 40\text{ns}$, where PS is the prescale value set in the SPIFMTx.[15:8] register bits.

For PS values of 0: $t_{c(SPC)M} = 2t_{c(VCLK)} \geq 40\text{ns}$.

The external load on the SPICLK pin must be less than 60pF.

(5) The active edge of the SPICLK signal referenced by the CLOCK POLARITY bit (SPIFMTx.17).

(6) C2TDELAY and T2CDELAY is programmed in the SPIDELAY register

Table 7-25. SPI Master Mode External Timing Parameters (CLOCK PHASE = 1, SPICLK = output, SPISIMO = output, and SPISOMI = input)⁽¹⁾⁽²⁾⁽³⁾ (continued)

NO.			MIN	MAX	UNIT
10	t_{SPIENA}	SPIENAn Sample Point	$(C2TDELAY+1) * t_{c(VCLK)} - t_{f(SPICS)} - 29$	$(C2TDELAY+1) * t_{c(VCLK)}$	ns
11	$t_{SPIENAW}$	SPIENAn Sample point from write to buffer	-40°C to 125°C	$(C2TDELAY+2) * t_{c(VCLK)}$	ns

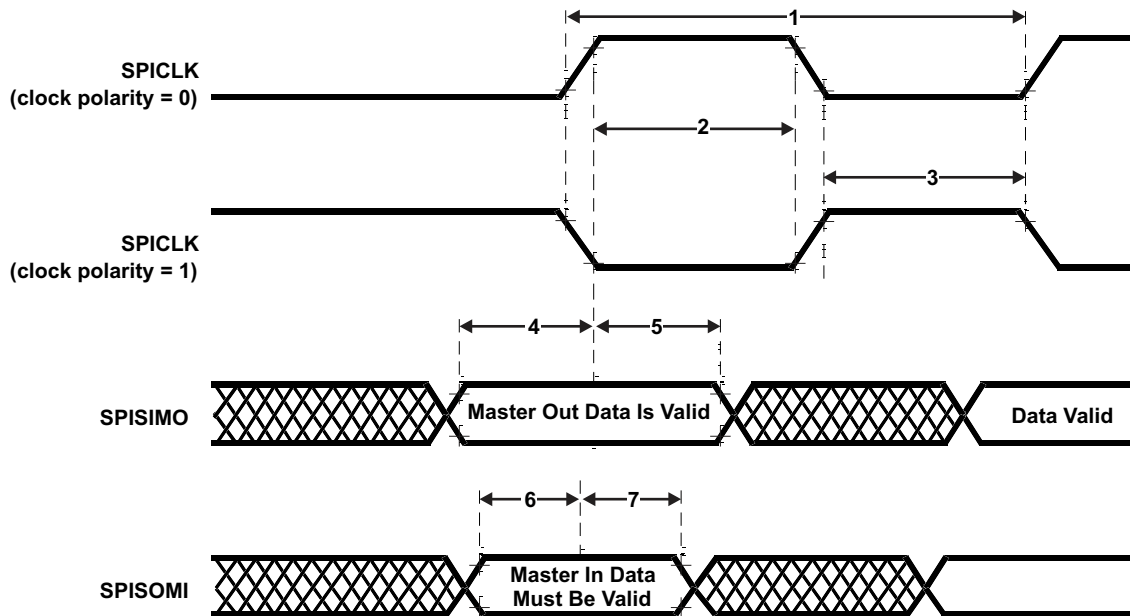

Figure 7-12. SPI Master Mode External Timing (CLOCK PHASE = 1)

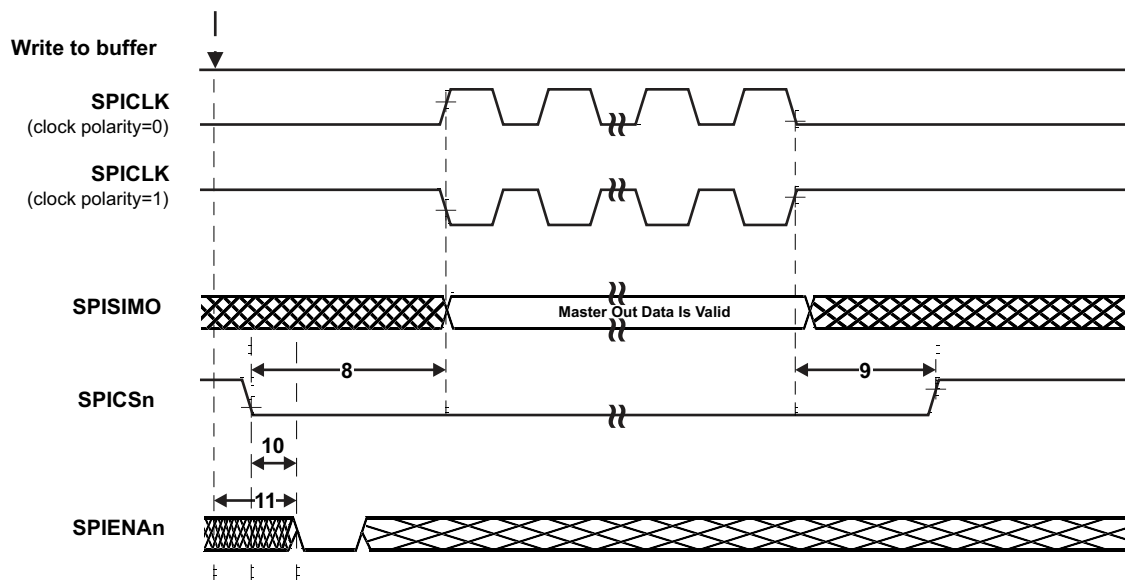

Figure 7-13. SPI Master Mode Chip Select Timing (CLOCK PHASE = 1)

7.10.5 SPI Slave Mode I/O Timings

Table 7-26. SPI Slave Mode External Timing Parameters (CLOCK PHASE = 0, SPICLK = input, SPISIMO = input, and SPISOMI = output)⁽¹⁾⁽²⁾⁽³⁾⁽⁴⁾

NO.				MIN	MAX	UNIT
1	$t_{c(SPC)S}$	Cycle time, SPICLK ⁽⁵⁾		40		ns
2 ⁽⁶⁾	$t_{w(SPCH)S}$	Pulse duration, SPICLK high (clock polarity = 0)	–40°C to 125°C	14		ns
	$t_{w(SPCL)S}$	Pulse duration, SPICLK low (clock polarity = 1)	–40°C to 125°C	14		
3 ⁽⁶⁾	$t_{w(SPCL)S}$	Pulse duration, SPICLK low (clock polarity = 0)	–40°C to 125°C	14		ns
	$t_{w(SPCH)S}$	Pulse duration, SPICLK high (clock polarity = 1)	–40°C to 125°C	14		
4 ⁽⁶⁾	$t_{d(SPCH-SOMI)S}$	Delay time, SPISOMI valid after SPICLK high (clock polarity = 0)			$t_{r(SOMI)} + 20$	ns
	$t_{d(SPCL-SOMI)S}$	Delay time, SPISOMI valid after SPICLK low (clock polarity = 1)			$t_{r(SOMI)} + 20$	
5 ⁽⁶⁾	$t_{h(SPCH-SOMI)S}$	Hold time, SPISOMI data valid after SPICLK high (clock polarity = 0)		2		ns
	$t_{h(SPCL-SOMI)S}$	Hold time, SPISOMI data valid after SPICLK low (clock polarity = 1)		2		
6 ⁽⁶⁾	$t_{su(SIMO-SPCL)S}$	Setup time, SPISIMO before SPICLK low (clock polarity = 0)		4		ns
	$t_{su(SIMO-SPCH)S}$	Setup time, SPISIMO before SPICLK high (clock polarity = 1)		4		
7 ⁽⁶⁾	$t_{h(SPCL-SIMO)S}$	Hold time, SPISIMO data valid after SPICLK low (clock polarity = 0)		2		ns
	$t_{h(SPCH-SIMO)S}$	Hold time, SPISIMO data valid after SPICLK high (clock polarity = 1)		2		
8	$t_{d(SPCL-SENAn)S}$	Delay time, SPIENAn high after last SPICLK low (clock polarity = 0)		$1.5t_{c(VCLK)}$	$2.5t_{c(VCLK)} + t_{r(ENAn)} + 22$	ns
	$t_{d(SPCH-SENAn)S}$	Delay time, SPIENAn high after last SPICLK high (clock polarity = 1)		$1.5t_{c(VCLK)}$	$2.5t_{c(VCLK)} + t_{r(ENAn)} + 22$	
9	$t_{d(SCSL-SENAL)S}$	Delay time, SPIENAn low after SPICLK low (if new data has been written to the SPI buffer)		$t_{f(ENAn)}$	$t_{c(VCLK)} + t_{f(ENAn)} + 27$	ns

- (1) The MASTER bit (SPIGCR1.0) is set and the CLOCK PHASE bit (SPIFMTx.16) is set.
- (2) If the SPI is in slave mode, the following must be true: $t_{c(SPC)S} \geq (PS + 1) t_{c(VCLK)}$, where PS = prescale value set in SPIFMTx.[15:8].
- (3) For rise and fall timings, see [Table 5-6](#).
- (4) $t_{c(VCLK)}$ = interface clock cycle time = $1 / f_{(VCLK)}$
- (5) When the SPI is in Slave mode, the following must be true:
For PS values from 1 to 255: $t_{c(SPC)S} \geq (PS + 1)t_{c(VCLK)} \geq 40ns$, where PS is the prescale value set in the SPIFMTx.[15:8] register bits.
For PS values of 0: $t_{c(SPC)S} = 2t_{c(VCLK)} \geq 40ns$.
- (6) The active edge of the SPICLK signal referenced is controlled by the CLOCK POLARITY bit (SPIFMTx.17).

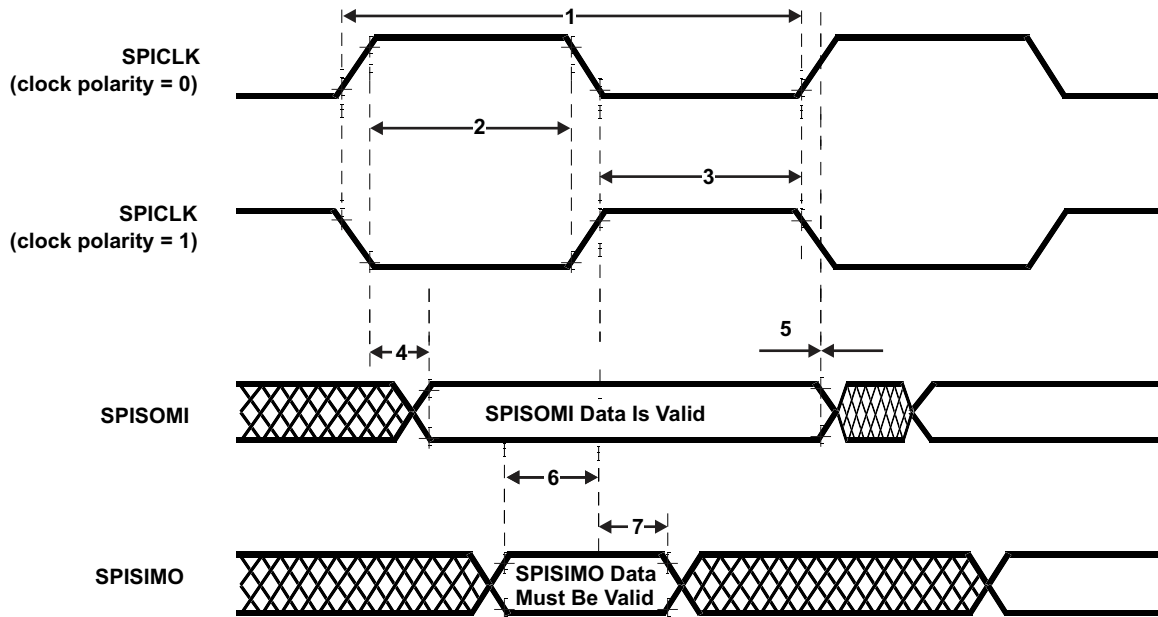

Figure 7-14. SPI Slave Mode External Timing (CLOCK PHASE = 0)

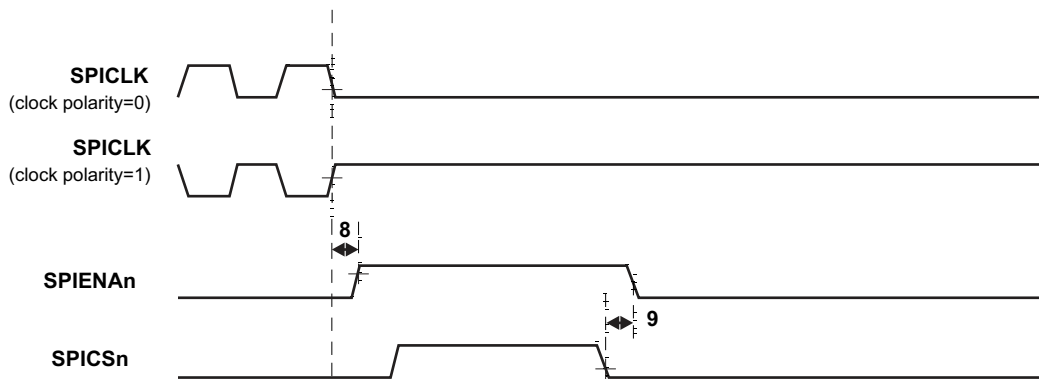

Figure 7-15. SPI Slave Mode Enable Timing (CLOCK PHASE = 0)

Table 7-27. SPI Slave Mode External Timing Parameters (CLOCK PHASE = 1, SPICLK = input, SPISIMO = input, and SPISOMI = output)⁽¹⁾⁽²⁾⁽³⁾⁽⁴⁾

NO.			MIN	MAX	UNIT
1	$t_{c(SPC)S}$	Cycle time, SPICLK ⁽⁵⁾	40		ns
2 ⁽⁶⁾	$t_{w(SPCH)S}$	Pulse duration, SPICLK high (clock polarity = 0)	–40°C to 125°C	14	ns
	$t_{w(SPCL)S}$	Pulse duration, SPICLK low (clock polarity = 1)	–40°C to 125°C	14	
3 ⁽⁶⁾	$t_{w(SPCL)S}$	Pulse duration, SPICLK low (clock polarity = 0)	–40°C to 125°C	14	ns
	$t_{w(SPCH)S}$	Pulse duration, SPICLK high (clock polarity = 1)	–40°C to 125°C	14	
4 ⁽⁶⁾	$t_{d(SOMI-SPCL)S}$	Delay time, SPISOMI data valid after SPICLK low (clock polarity = 0)		$t_{r(SOMI)} + 20$	ns
	$t_{d(SOMI-SPCH)S}$	Delay time, SPISOMI data valid after SPICLK high (clock polarity = 1)		$t_{r(SOMI)} + 20$	
5 ⁽⁶⁾	$t_{h(SPCL-SOMI)S}$	Hold time, SPISOMI data valid after SPICLK high (clock polarity = 0)		2	ns
	$t_{h(SPCH-SOMI)S}$	Hold time, SPISOMI data valid after SPICLK low (clock polarity = 1)		2	
6 ⁽⁶⁾	$t_{su(SIMO-SPCH)S}$	Setup time, SPISIMO before SPICLK high (clock polarity = 0)		4	ns
	$t_{su(SIMO-SPCL)S}$	Setup time, SPISIMO before SPICLK low (clock polarity = 1)		4	
7 ⁽⁶⁾	$t_{v(SPCH-SIMO)S}$	High time, SPISIMO data valid after SPICLK high (clock polarity = 0)		2	ns
	$t_{v(SPCL-SIMO)S}$	High time, SPISIMO data valid after SPICLK low (clock polarity = 1)		2	
8	$t_{d(SPCH-SENAn)S}$	Delay time, SPIENAn high after last SPICLK high (clock polarity = 0)		$1.5t_{c(VCLK)}$ $2.5t_{c(VCLK)} + t_{r(ENAn)} + 22$	ns
	$t_{d(SPCL-SENAn)S}$	Delay time, SPIENAn high after last SPICLK low (clock polarity = 1)		$1.5t_{c(VCLK)}$ $2.5t_{c(VCLK)} + t_{r(ENAn)} + 22$	
9	$t_{d(SCSL-SENAL)S}$	Delay time, SPIENAn low after SPICLSn low (if new data has been written to the SPI buffer)		$t_{r(ENAn)}$ $t_{c(VCLK)} + t_{r(ENAn)} + 27$	ns
10	$t_{d(SCSL-SOMI)S}$	Delay time, SOMI valid after SPICLSn low (if new data has been written to the SPI buffer)		$t_{c(VCLK)}$ $2t_{c(VCLK)} + t_{r(SOMI)} + 28$	ns

- (1) The MASTER bit (SPIGCR1.0) is set and the CLOCK PHASE bit (SPIFMTx.16) is set.
(2) If the SPI is in slave mode, the following must be true: $t_{c(SPC)S} \leq (PS + 1) t_{c(VCLK)}$, where PS = prescale value set in SPIFMTx.[15:8].
(3) For rise and fall timings, see [Table 5-6](#).
(4) $t_{c(VCLK)}$ = interface clock cycle time = $1 / f_{(VCLK)}$
(5) When the SPI is in Slave mode, the following must be true:
For PS values from 1 to 255: $t_{c(SPC)S} \geq (PS + 1)t_{c(VCLK)} \geq 40ns$, where PS is the prescale value set in the SPIFMTx.[15:8] register bits.
For PS values of 0: $t_{c(SPC)S} = 2t_{c(VCLK)} \geq 40ns$.
(6) The active edge of the SPICLK signal referenced is controlled by the CLOCK POLARITY bit (SPIFMTx.17).

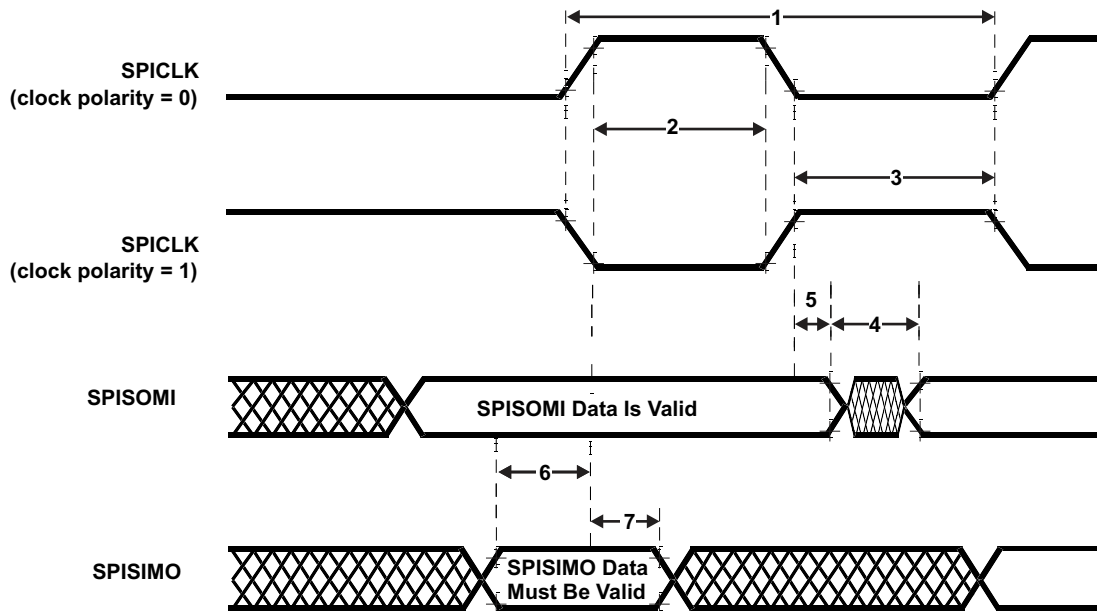

Figure 7-16. SPI Slave Mode External Timing (CLOCK PHASE = 1)

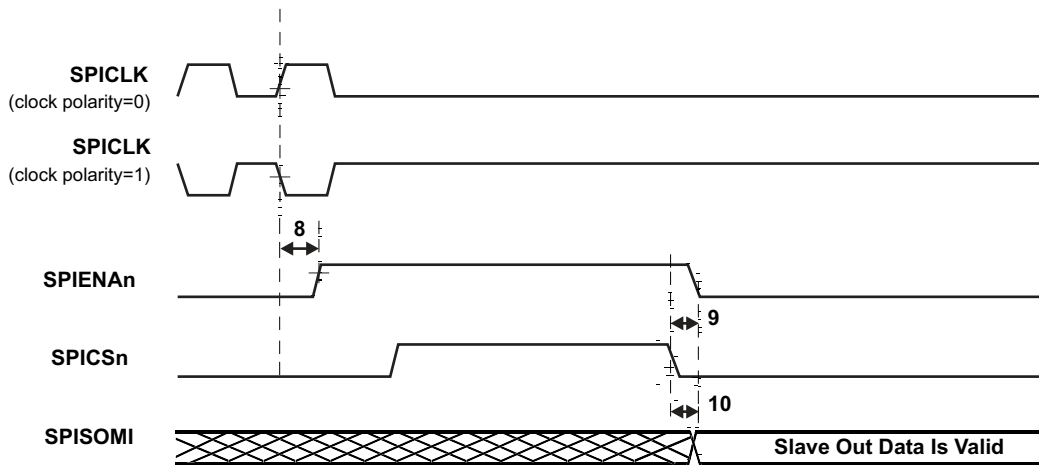

Figure 7-17. SPI Slave Mode Enable Timing (CLOCK PHASE = 1)

7.11 Ethernet Media Access Controller

The Ethernet Media Access Controller (EMAC) provides an efficient interface between the CPU and the network. The EMAC supports both 10Base-T and 100Base-TX, or 10 Mbits/second (Mbps) and 100 Mbps in either half- or full-duplex mode, with hardware flow control and quality of service (QoS) support.

The EMAC controls the flow of packet data from the device to the PHY. The MDIO module controls PHY configuration and status monitoring.

Both the EMAC and the MDIO modules interface to the device through a custom interface that allows efficient data transmission and reception. This custom interface is referred to as the EMAC control module, and is considered integral to the EMAC/MDIO peripheral. The control module is also used to multiplex and control interrupts.

7.11.1 Ethernet MII Electrical and Timing Specifications

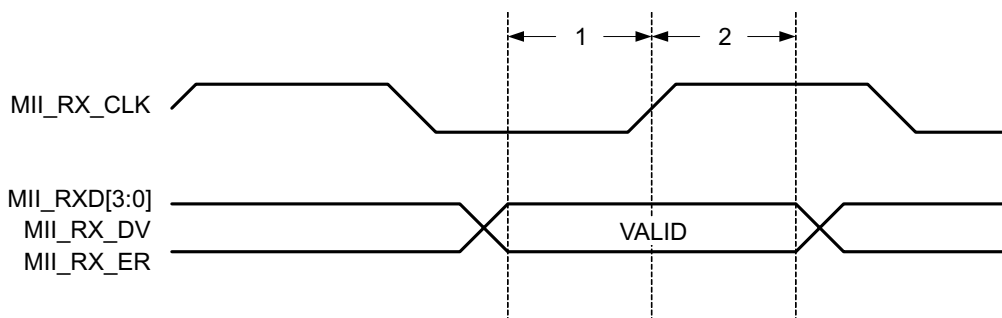

Figure 7-18. MII Receive Timing

Table 7-28. MII Receive Timing

		MIN	MAX	UNIT
$t_{su}(MIIMRXD)$	Setup time, MIIMRXD to MIIMRCLK rising edge	8		ns
$t_{su}(MIIMRXDV)$	Setup time, MIIMRXDV to MIIMRCLK rising edge	8		ns
$t_{su}(MIIMRXER)$	Setup time, MIIMRXER to MIIMRCLK rising edge	8		ns
$t_h(MIIMRXD)$	Hold time, MIIMRXD valid after MIIRCLK rising edge	8		ns
$t_h(MIIMRXDV)$	Hold time, MIIMRXDV valid after MIIRCLK rising edge	8		ns
$t_h(MIIMRXER)$	Hold time, MIIMRXDV valid after MIIRCLK rising edge	8		ns

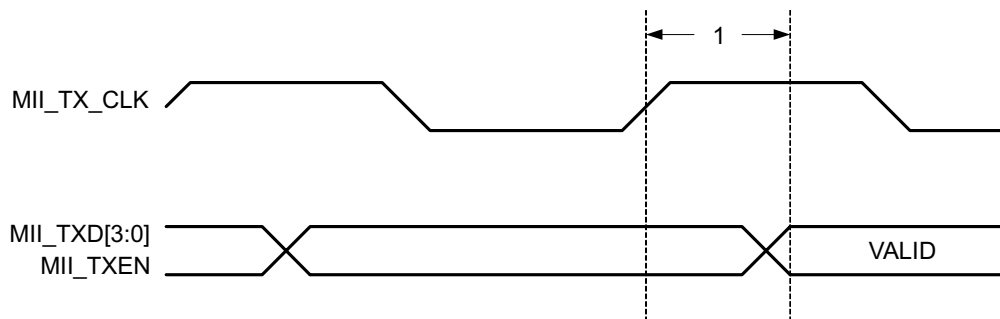

Figure 7-19. MII Transmit Timing

Table 7-29. MII Transmit Timing

		MIN	MAX	UNIT
$t_{d(MIIMTXD)}$	Delay time, MIIMTCLK rising edge to MIIMTXD	5	25	ns
$t_{d(MIIMTXEN)}$	Delay time, MIIMTCLK rising edge to MIIMTXEN	5	25	ns

7.11.2 Ethernet RMII Timing

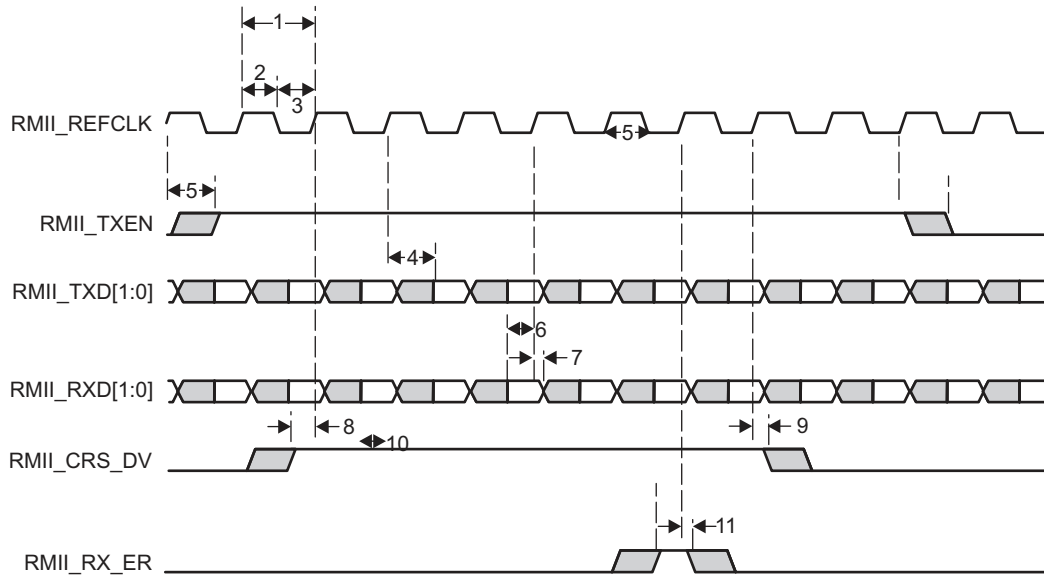

Figure 7-20. RMII Timing Diagram

Table 7-30. RMII Timing Requirements

NO.			MIN	NOM	MAX	UNIT
1	tc(REFCLK)	Cycle time, RMII_REF_CLK	—	20	—	ns
2	tw(REFCLKH)	Pulse width, RMII_REF_CLK High	7	—	13	ns
3	tw(REFCLKL)	Pulse width, RMII_REF_CLK Low	7	—	13	ns
6	tsu(RXD-REFCLK)	Input setup time, RMII_RXD valid before RMII_REF_CLK High	4	—	—	ns
7	th(REFCLK-RXD)	Input hold time, RMII_RXD valid after RMII_REF_CLK High	2	—	—	ns
8	tsu(CRSDV-REFCLK)	Input setup time, RMII_CRSDV valid before RMII_REF_CLK High	4	—	—	ns
9	th(REFCLK-CRSDV)	Input hold time, RMII_CRSDV valid after RMII_REF_CLK High	2	—	—	ns
10	tsu(RXER-REFCLK)	Input setup time, RMII_RXER valid before RMII_REF_CLK High	4	—	—	ns
11	th(REFCLK-RXER)	Input hold time, RMII_RXER valid after RMII_REF_CLK High	2	—	—	ns
4	td(REFCLK-TXD)	Output delay time, RMII_REF_CLK High to RMII_TXD valid	2	—	—	ns
5	td(REFCLK-TXEN)	Output delay time, RMII_REF_CLK High to RMII_TX_EN valid	2	—	—	ns

7.11.3 Management Data Input/Output (MDIO)

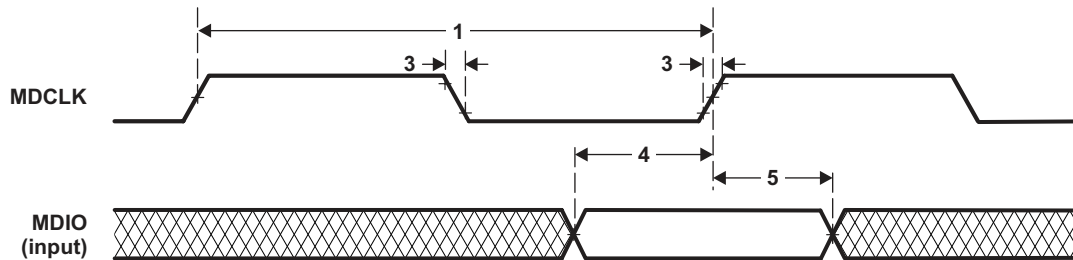

Figure 7-21. MDIO Input Timing

Table 7-31. MDIO Input Timing Requirements

NO.		MIN	MAX	UNIT
1	tc(MDCLK) Cycle time, MDCLK	400	—	ns
2	tw(MDCLK) Pulse duration, MDCLK high/low	180	—	ns
3	tt(MDCLK) Transition time, MDCLK	—	5	ns
4	tsu(MDIO-MDCLKH) Setup time, MDIO data input valid before MDCLK high	33 ⁽¹⁾	—	ns
5	th(MDCLKH-MDIO) Hold time, MDIO data input valid after MDCLK high	10	—	ns

(1) This is a discrepancy to IEEE 802.3, but is compatible with many PHY devices.

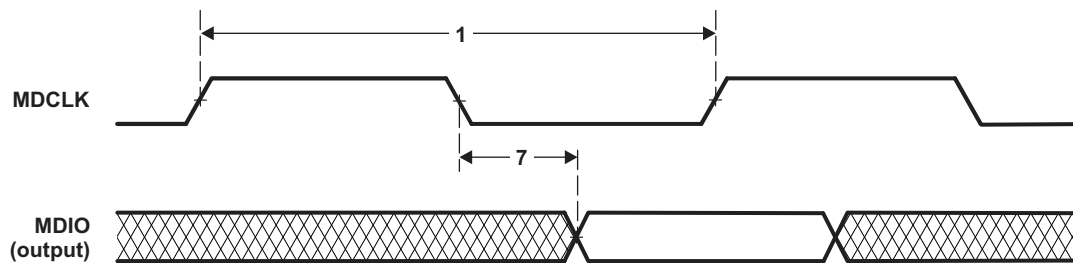

Figure 7-22. MDIO Output Timing

Table 7-32. MDIO Output Timing Requirements

NO.		MIN	MAX	UNIT
1	tc(MDCLK) Cycle time, MDCLK	400	—	ns
7	td(MDCLKL-MDIO) Delay time, MDCLK low to MDIO data output valid	-7	100	ns

8 Device and Documentation Support

8.1 Device and Development-Support Tool Nomenclature

To designate the stages in the product development cycle, TI assigns prefixes to the part numbers of all devices. Each commercial family member has one of three prefixes: TMX, TMP, or TMS (for example, **TMS570LS3137**). These prefixes represent evolutionary stages of product development from engineering prototypes (TMX) through fully qualified production devices/tools (TMS).

Device development evolutionary flow:

- TMX** Experimental device that is not necessarily representative of the final device's electrical specifications.
- TMP** Final silicon die that conforms to the device's electrical specifications but has not completed quality and reliability verification.
- TMS** Fully-qualified production device.

TMX and TMP devices are shipped against the following disclaimer:

"Developmental product is intended for internal evaluation purposes."

TMS devices have been characterized fully, and the quality and reliability of the device have been demonstrated fully. TI's standard warranty applies.

Predictions show that prototype devices (TMX or TMP) have a greater failure rate than the standard production devices. Texas Instruments recommends that these devices not be used in any production system because their expected end-use failure rate still is undefined. Only qualified production devices are to be used.

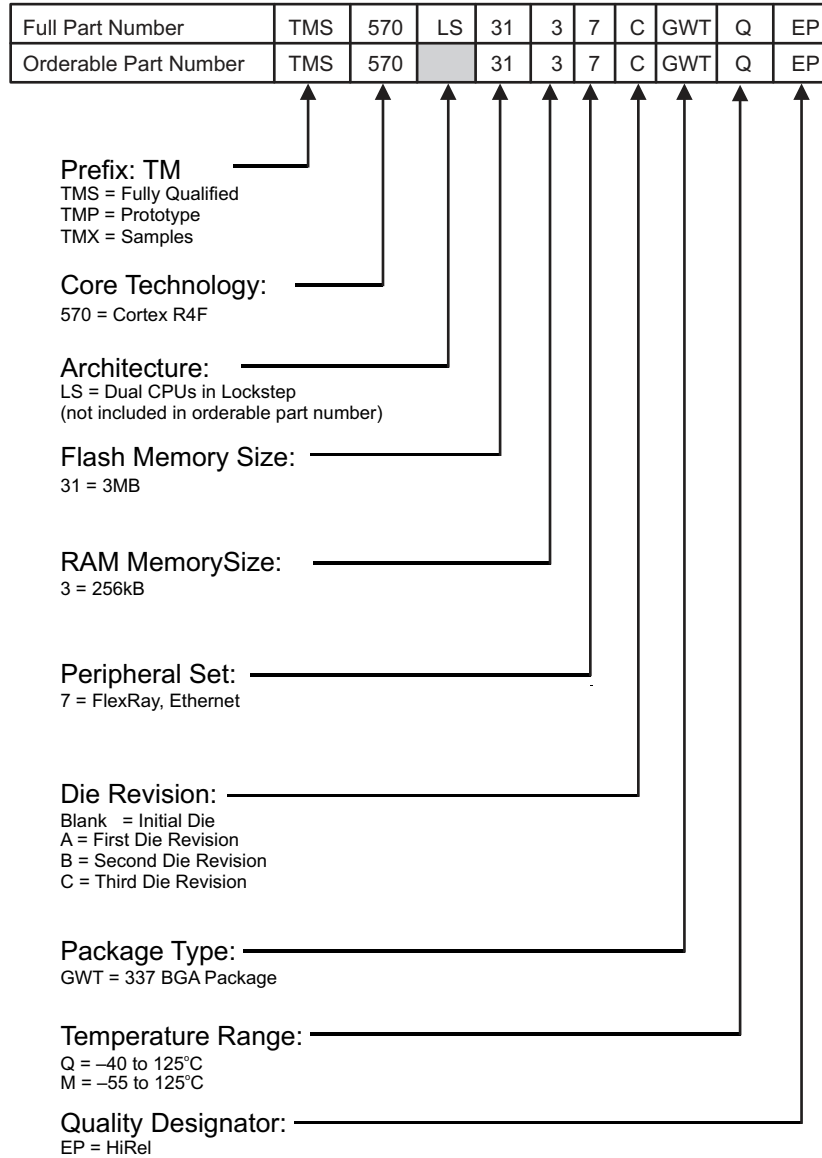

Figure 8-1. TMS570LS3137-EP Device Numbering Conventions

8.2 Documentation Support

8.2.1 Related Documentation from Texas Instruments

The following documents describe the TMS570LS3137-EP microcontroller.

SPNU499	<i>TMS570LS31x/21x 16/32-Bit RISC Flash Microcontroller Technical Reference Manual</i> details the integration, the environment, the functional description, and the programming models for each peripheral and subsystem in the device.
SPNZ195	<i>TMS570LS31x/21x Microcontroller Silicon Errata (Silicon Revision C)</i> describes the known exceptions to the functional specifications for the device silicon revision(s).

8.2.2 Community Resources

The following links connect to TI community resources. Linked contents are provided "AS IS" by the respective contributors. They do not constitute TI specifications and do not necessarily reflect TI's views; see TI's [Terms of Use](#).

[TI E2E™ Online Community](#) *TI's Engineer-to-Engineer (E2E) Community*. Created to foster collaboration among engineers. At e2e.ti.com, you can ask questions, share knowledge, explore ideas and help solve problems with fellow engineers.

[TI Embedded Processors Wiki](#) *Texas Instruments Embedded Processors Wiki*. Established to help developers get started with Embedded Processors from Texas Instruments and to foster innovation and growth of general knowledge about the hardware and software surrounding these devices.

8.3 Trademarks

E2E is a trademark of Texas Instruments.
Cortex is a trademark of ARM Limited.
ARM is a registered trademark of ARM Limited.
All other trademarks are the property of their respective owners.

8.4 Electrostatic Discharge Caution



These devices have limited built-in ESD protection. The leads should be shorted together or the device placed in conductive foam during storage or handling to prevent electrostatic damage to the MOS gates.

8.5 Glossary

[SLYZ022](#) — *TI Glossary*.

This glossary lists and explains terms, acronyms, and definitions.

8.6 Device Identification

8.6.1 Device Identification Code Register

The device identification code register identifies several aspects of the device including the silicon version. The details of the device identification code register are shown in [Table 8-1](#). The device identification code register value for this device is:

- Rev A = 0x802AAD05
- Rev B = 0x802AAD15
- Rev C = 0x802AAD1D

Figure 8-2. Device ID Bit Allocation Register

31	30	29	28	27	26	25	24
CP-15	UNIQUE ID						
R-1	R-0000000						
23	22	21	20	19	18	17	16
UNIQUE ID							TECH
R-0010101							R-0
15	14	13	12	11	10	9	8
TECH			I/O VOLTAGE	PERIPH PARITY	FLASH ECC		RAM ECC
R-101			R-0	R-1	R-10		R-1
7	6	5	4	3	2	1	0
VERSION					1	0	1
R-00000					R-1	R-0	R-1

LEGEND: R/W = Read/Write; R = Read only; -n = value after reset

Table 8-1. Device ID Bit Allocation Register Field Descriptions

Bit	Field	Value	Description
31	CP15	1	Indicates the presence of coprocessor 15 CP15 present
30-17	UNIQUE ID	10101	Silicon version (revision) bits. This bitfield holds a unique number for a dedicated device configuration (die).
16-13	TECH	0101	Process technology on which the device is manufactured. F021
12	I/O VOLTAGE	0	I/O voltage of the device. I/O are 3.3v
11	PERIPHERAL PARITY	1	Peripheral Parity Parity on peripheral memories
10-9	FLASH ECC	10	Flash ECC Program memory with ECC
8	RAM ECC	1	Indicates if RAM memory ECC is present. ECC implemented
7-3	REVISION		Revision of the Device.
2-0	101		The platform family ID is always 0b101

8.6.2 Die Identification Registers

The four die ID registers at addresses 0xFFFFE1F0, 0xFFFFE1F4, 0xFFFFE1F8 and FFFFE1FC form a 128-bit dieid with the information as shown in [Table 8-2](#).

Table 8-2. Die-ID Registers

Item	Number of Bits	Bit Location
X-coordinate on wafer	12	0xFFFFE1F0[11:0]
Y-coordinate on wafer	12	0xFFFFE1F0[23:12]
Wafer number	8	0xFFFFE1F0[31:24]
Lot number	24	0xFFFFE1F4[23:0]
Reserved	72	0xFFFFE1F4[31:24], 0xFFFFE1F8[31:0], 0xFFFFE1FC[31:0]

8.7 Module Certifications

The following communications modules have received certification of adherence to a standard.

FlexRay™ Certifications

FlexRay™ Protocol Conformance Certificate

Device (IUT):
Name: TMS570LS3137 Rev C , TMS570LS3136 Rev C
TMS570LS3135 Rev C , TMS570LS2135 Rev C
TMS570LS2125 Rev C

Package: ZWT (S-PBGA-N337) Plastic Ball Grid Array

Version: Core Release Register: 0x10390206 (CREL[31:0])
Device Identification Code: 0x802AAD1D (DEVID[31:0])

Vendor: Texas Instruments Incorporated
12500 TI Boulevard
Dallas, Texas 75243
USA

Test basis:	Test execution:
FlexRay™ protocol version: 2.1 / 2.1RevA	Date: 27.04.2013
Test specification version: 2.1.2	Hour of completion: 04:37

Test results:	Test report:
Test cases executed: 275	Execution ID: TMP570LS3136ZWT1367030227819
Test cases passed: 275	
Test cases failed: 0	

Essen, 10.05.2013

Heiko Ehrich
Digital unterzeichnet von Heiko Ehrich
Digitale Medien GmbH, c/o TÜV NORD
Mobilität GmbH & Co. KG, c/o TÜV NORD
T.N. - email: heiko.ehrich@tuvnord.de, CN:
Heiko Ehrich, O=Digital, OU=TÜV NORD

TÜV NORD Mobilität GmbH & Co.KG
Institute for Vehicle Technology and Mobility

IUT-Details – According to the vendor's data sheet, the IUT has the following peculiarities and optional features:

Peculiarity	Value
MTS transmission activation adjustment time-string	0:x:x:0:0:0
MTS transmission deactivation adjustment time-string	0:x:x:0:0:0
MTS transmission deactivation required	False
cIntDecoderDelay [ST]	8
cColdstartCollisionAbortDelay [µT]	10
Message ID filtering impl. Via valid message indicator	False

Optional feature	Supported/Unsupported
Message ID filtering	Unsupported
Relative timer	Supported
Network Management Vector	Supported
(Re)setting of the 'transmit buffer valid flag'	Supported

This certificate is valid for the hardware and software configuration documented in the test report.



Figure 8-3. Flexray Certification for GWT Package

DCAN Certification

<p>Testhouse C&S group GmbH Am Exer 19b D-38302 Wolfenbuettel Phone: +49 5331/90 555-0 Fax: +49 5331/90 555-110</p>	
---	----------

Authentication

Texas Instruments

on CAN Conformance

P10_0294_021_CAN_DL_Test_Authentication_r01.doc

Date of Approval: 2011-Feb-08

C&S is worldwide recognized as a neutral expert in testing of communication systems such as CAN Transceiver, CAN, CAN Software Drivers, (CAN) Network Management, FlexRay and LIN.

Herewith C&S group is proud to confirm that the followings tests on the subsequently specified device implementations have been performed by C&S resulting in the findings given below:

C&S Conformance Test Results

Manufacturer	Texas Instruments
Component/Part Number	TMSx70 x021 Microcontroller Family, DCAN Core Release 0xA3170504, 980 A2C0007940000 X470MUF C63C1 P80576 24 YFB-08A9X6W
Date of Tests	February 2011
Version of Test Specification	CAN Conformance Test 1 ISO CAN Conformance Tests according to "ISO 16845:2004 Road vehicles - Controller area network (CAN) - Conformance test plan" and C&S enhancement/ corrections according to "CAN CONFORMANCE TESTING Test Specification C&S Version 2.0 RC" 2 C&S Register Functionality Tests according to "C&S Register Functionality Test Specification V2.0" 3 C&S Robustness Tests according to "C&S Robustness Test Specification V1.4"
Corresponding Test Report	P10_0294_020_CAN_DL_Test_report_r01
1 ISO CAN conformance tests	Pass
2 C&S Register Functionality tests	Pass
3 C&S Robustness tests	Pass
• Further Observations	None

Frank Fischer, CTO

Lothar Kukla, Project Manager

Quote No. P10_0294 R01

Figure 8-4. DCAN Certification

9 Mechanical, Packaging, and Orderable Information

9.1 Packaging Information

The following packaging information reflects the most current released data available for the designated device(s). This data is subject to change without notice and without revision of this document.

PACKAGING INFORMATION

Orderable Device	Status (1)	Package Type	Package Drawing	Pins	Package Qty	Eco Plan (2)	Lead finish/ Ball material (6)	MSL Peak Temp (3)	Op Temp (°C)	Device Marking (4/5)	Samples
TMS5703137CGWTMEP	ACTIVE	NFBGA	GWT	337	90	Non-RoHS & Green	SNPB	Level-3-220C-168 HR	-55 to 125	TMS570 LS3137CGWTMEP	Samples
TMS5703137CGWTQEP	ACTIVE	NFBGA	GWT	337	90	Non-RoHS & Green	SNPB	Level-3-220C-168 HR	-40 to 125	TMS570 LS3137CGWTQEP	Samples
V62/13629-01XE	ACTIVE	NFBGA	GWT	337	90	Non-RoHS & Green	SNPB	Level-3-220C-168 HR	-40 to 125	TMS570 LS3137CGWTQEP	Samples
V62/13629-02XE	ACTIVE	NFBGA	GWT	337	90	Non-RoHS & Green	SNPB	Level-3-220C-168 HR	-55 to 125	TMS570 LS3137CGWTMEP	Samples

(1) The marketing status values are defined as follows:

ACTIVE: Product device recommended for new designs.

LIFEBUY: TI has announced that the device will be discontinued, and a lifetime-buy period is in effect.

NRND: Not recommended for new designs. Device is in production to support existing customers, but TI does not recommend using this part in a new design.

PREVIEW: Device has been announced but is not in production. Samples may or may not be available.

OBSELETE: TI has discontinued the production of the device.

(2) **RoHS:** TI defines "RoHS" to mean semiconductor products that are compliant with the current EU RoHS requirements for all 10 RoHS substances, including the requirement that RoHS substance do not exceed 0.1% by weight in homogeneous materials. Where designed to be soldered at high temperatures, "RoHS" products are suitable for use in specified lead-free processes. TI may reference these types of products as "Pb-Free".

RoHS Exempt: TI defines "RoHS Exempt" to mean products that contain lead but are compliant with EU RoHS pursuant to a specific EU RoHS exemption.

Green: TI defines "Green" to mean the content of Chlorine (Cl) and Bromine (Br) based flame retardants meet JS709B low halogen requirements of <=1000ppm threshold. Antimony trioxide based flame retardants must also meet the <=1000ppm threshold requirement.

(3) MSL, Peak Temp. - The Moisture Sensitivity Level rating according to the JEDEC industry standard classifications, and peak solder temperature.

(4) There may be additional marking, which relates to the logo, the lot trace code information, or the environmental category on the device.

(5) Multiple Device Markings will be inside parentheses. Only one Device Marking contained in parentheses and separated by a "~" will appear on a device. If a line is indented then it is a continuation of the previous line and the two combined represent the entire Device Marking for that device.

(6) Lead finish/Ball material - Orderable Devices may have multiple material finish options. Finish options are separated by a vertical ruled line. Lead finish/Ball material values may wrap to two lines if the finish value exceeds the maximum column width.

Important Information and Disclaimer:The information provided on this page represents TI's knowledge and belief as of the date that it is provided. TI bases its knowledge and belief on information provided by third parties, and makes no representation or warranty as to the accuracy of such information. Efforts are underway to better integrate information from third parties. TI has taken and

continues to take reasonable steps to provide representative and accurate information but may not have conducted destructive testing or chemical analysis on incoming materials and chemicals. TI and TI suppliers consider certain information to be proprietary, and thus CAS numbers and other limited information may not be available for release.

In no event shall TI's liability arising out of such information exceed the total purchase price of the TI part(s) at issue in this document sold by TI to Customer on an annual basis.

OTHER QUALIFIED VERSIONS OF TMS570LS3137-EP :

- Catalog : [TMS570LS3137](#)

NOTE: Qualified Version Definitions:

- Catalog - TI's standard catalog product

TRAY

Chamfer on Tray corner indicates Pin 1 orientation of packed units.

*All dimensions are nominal

Device	Package Name	Package Type	Pins	SPQ	Unit array matrix	Max temperature (°C)	L (mm)	W (mm)	K0 (µm)	P1 (mm)	CL (mm)	CW (mm)
TMS5703137CGWTME P	GWT	NFBGA	337	90	6 X 15	150	315	135.9	7620	20	17.5	15.45
TMS5703137CGWTQEP	GWT	NFBGA	337	90	6 X 15	150	315	135.9	7620	20	17.5	15.45
V62/13629-01XE	GWT	NFBGA	337	90	6 X 15	150	315	135.9	7620	20	17.5	15.45
V62/13629-02XE	GWT	NFBGA	337	90	6 X 15	150	315	135.9	7620	20	17.5	15.45

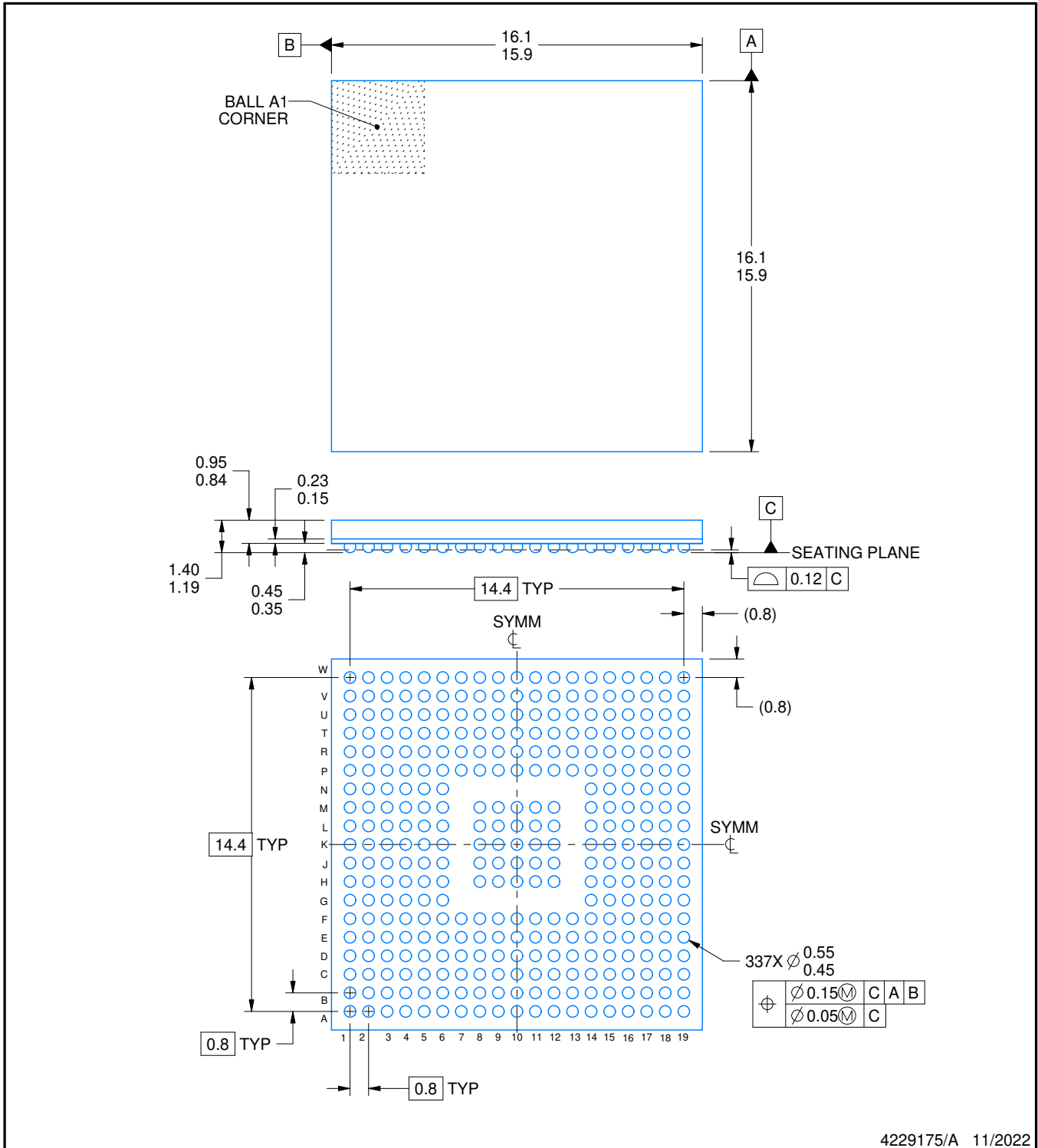
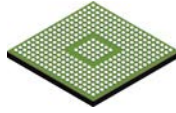

4229175/A 11/2022

NOTES:

1. All linear dimensions are in millimeters. Any dimensions in parenthesis are for reference only. Dimensioning and tolerancing per ASME Y14.5M.
2. This drawing is subject to change without notice.

EXAMPLE BOARD LAYOUT

GWT0337A

NFBGA - 1.4 mm max height

PLASTIC BALL GRID ARRAY

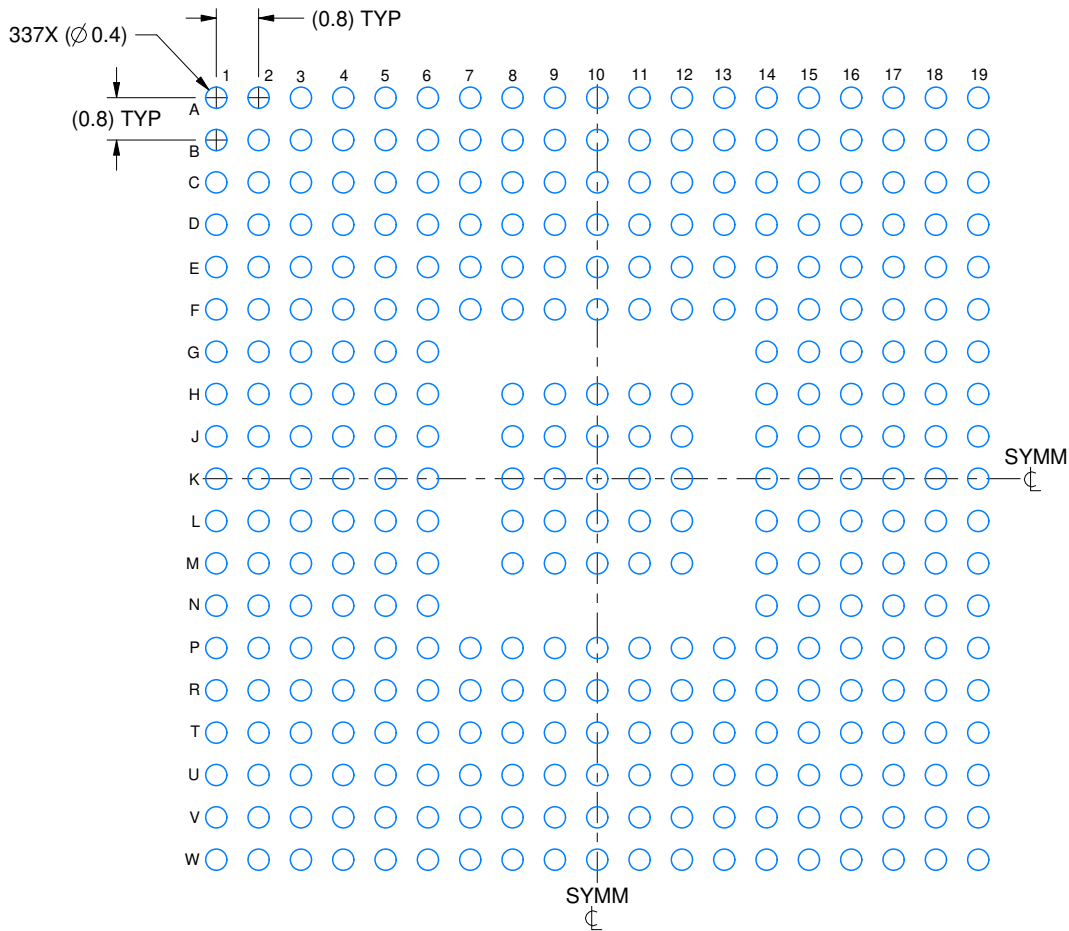

LAND PATTERN EXAMPLE
EXPOSED METAL SHOWN
SCALE: 7X

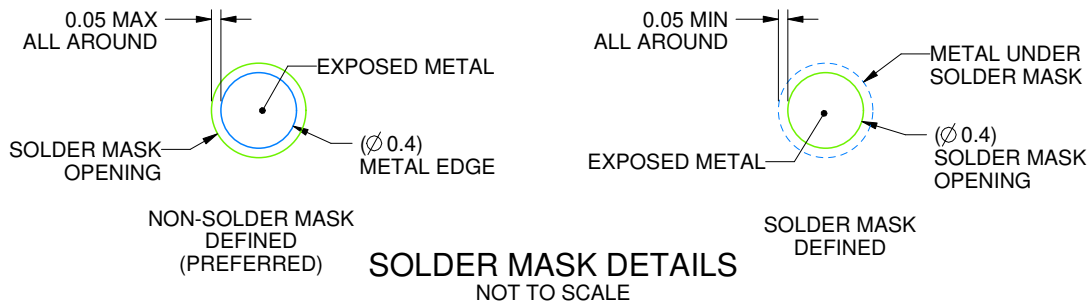

4229175/A 11/2022

NOTES: (continued)

- Final dimensions may vary due to manufacturing tolerance considerations and also routing constraints. For information, see Texas Instruments literature number SPRAA99 (www.ti.com/lit/spraa99).

EXAMPLE STENCIL DESIGN

GWT0337A

NFBGA - 1.4 mm max height

PLASTIC BALL GRID ARRAY

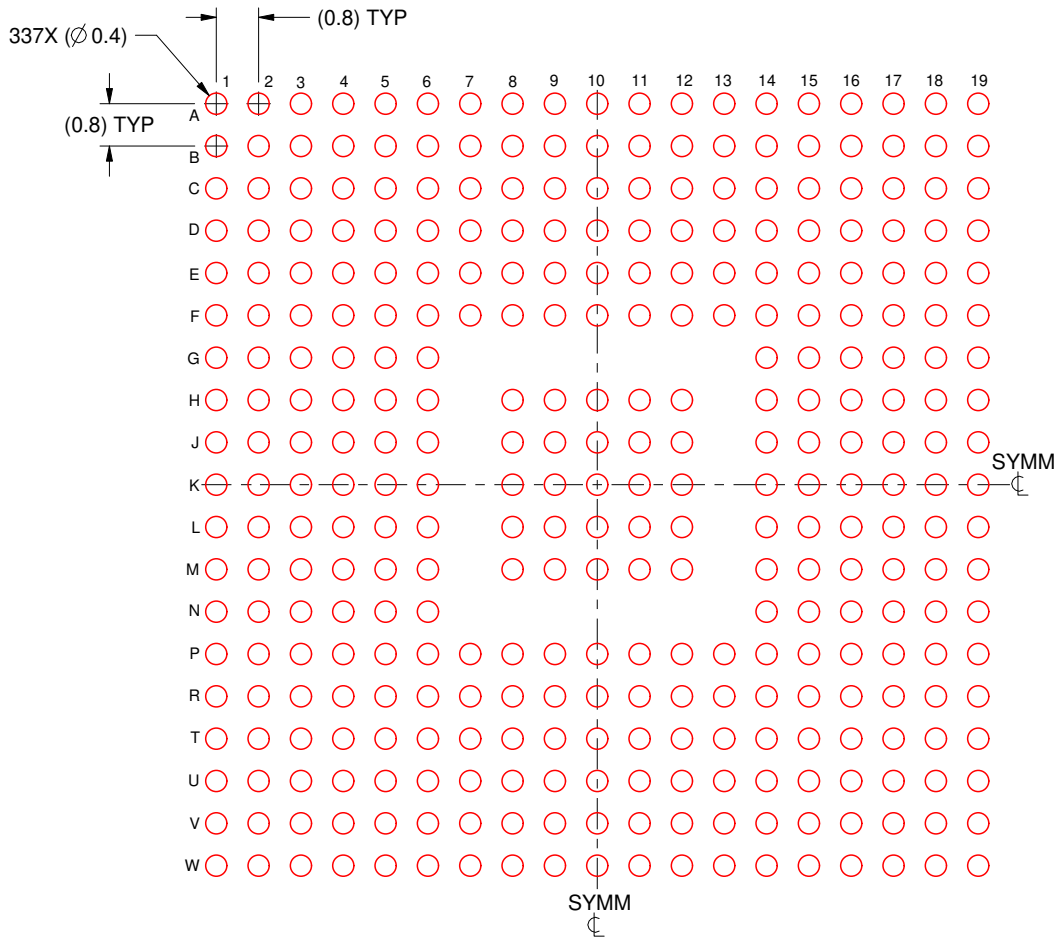

SOLDER PASTE EXAMPLE
BASED ON 0.150 mm THICK STENCIL
SCALE: 7X

4229175/A 11/2022

NOTES: (continued)

4. Laser cutting apertures with trapezoidal walls and rounded corners may offer better paste release.

IMPORTANT NOTICE AND DISCLAIMER

TI PROVIDES TECHNICAL AND RELIABILITY DATA (INCLUDING DATA SHEETS), DESIGN RESOURCES (INCLUDING REFERENCE DESIGNS), APPLICATION OR OTHER DESIGN ADVICE, WEB TOOLS, SAFETY INFORMATION, AND OTHER RESOURCES "AS IS" AND WITH ALL FAULTS, AND DISCLAIMS ALL WARRANTIES, EXPRESS AND IMPLIED, INCLUDING WITHOUT LIMITATION ANY IMPLIED WARRANTIES OF MERCHANTABILITY, FITNESS FOR A PARTICULAR PURPOSE OR NON-INFRINGEMENT OF THIRD PARTY INTELLECTUAL PROPERTY RIGHTS.

These resources are intended for skilled developers designing with TI products. You are solely responsible for (1) selecting the appropriate TI products for your application, (2) designing, validating and testing your application, and (3) ensuring your application meets applicable standards, and any other safety, security, regulatory or other requirements.

These resources are subject to change without notice. TI grants you permission to use these resources only for development of an application that uses the TI products described in the resource. Other reproduction and display of these resources is prohibited. No license is granted to any other TI intellectual property right or to any third party intellectual property right. TI disclaims responsibility for, and you will fully indemnify TI and its representatives against, any claims, damages, costs, losses, and liabilities arising out of your use of these resources.

TI's products are provided subject to [TI's Terms of Sale](#) or other applicable terms available either on ti.com or provided in conjunction with such TI products. TI's provision of these resources does not expand or otherwise alter TI's applicable warranties or warranty disclaimers for TI products.

TI objects to and rejects any additional or different terms you may have proposed.

Mailing Address: Texas Instruments, Post Office Box 655303, Dallas, Texas 75265
Copyright © 2022, Texas Instruments Incorporated